

*International specialized medium for agricultural mechanization in developing countries*

ISSN 0084-5841

# AMA

**AGRICULTURAL MECHANIZATION IN ASIA, AFRICA AND LATIN AMERICA**

VOL.22, NO.1, WINTER 1991

---

**Special Issue:**

**The Farm Machinery Industry in Japan  
and Research Activities**

**FARM MACHINERY INDUSTRIAL RESEARCH CORP.**



# Kubota farm machinery handles most any job on earth.

Wherever there's work to be done around the world, you'll find Kubota on the job. Because Kubota makes a comprehensive line of agricultural equipment, including tractors ranging from light, efficient 9-horsepower compacts to powerful giants up to 115-horsepower. In fact, you can select from more than 30 Kubota tractor models to handle everything from home or commercial lawn care and light construction, to the biggest jobs on the biggest farms. And every piece of farm machinery

that's come off Kubota's automated production line for more than 100 years has carried our legendary engineering for top performance and versatility. So wherever you have a job to do, turn to Japan's number one agricultural equipment manufacturer. Kubota. There's nothing like it on earth.

## Kubota

### KUBOTA Corporation

Head Office: 2-47, Shikitsuhigashi 1-Chome, Naniwa-Ku, Osaka, Japan Phone: 06-648-2434 Telex: J65251 KUBOTA A Fax: 06-648-3521  
Tokyo Office: 1-3, Nihonbashi-Muromachi 3-Chome, Chuo-Ku, Tokyo, Japan Phone: 03-3245-3635 Telex: 222-3671 KUBOTA J Fax: 03-3245-3629



# YAMAMOTO GRAIN PROCESSING MACHINES

## FOR THE 90'S!!

Yamamoto Co., Ltd. was established in 1918. We have specialized in agricultural machinery and deeply committed in research and development of the field as long as more 70 years. Our main products are Grain Drying & Storage Bin, Grain Dryers, Pre-cleaners, Paddy Husking Machine, Rice Whitening Machines, Soybean Processing Machines, Feed Cutters and Wood Chipping Machines. Especially, our Grain Dryers and Feed Cutters have been enjoying the biggest market share in domestic market. Our agricultural machines will help you and your business.

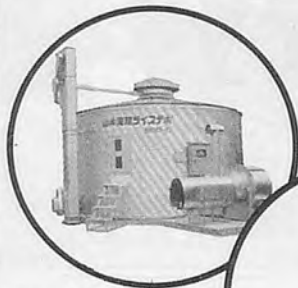

DRYING & STORAGE BIN



GRAIN DRYER

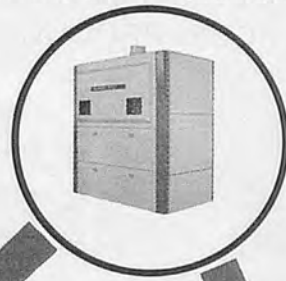

PRE-CLEANER



RICE WHITENING MACHINE  
(VERTICAL TYPE)

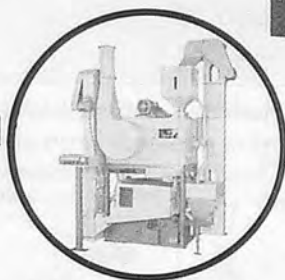

PADDY HUSKING MACHINE

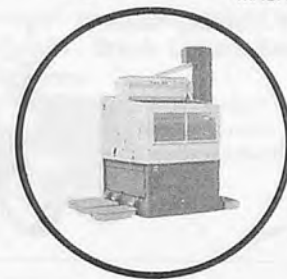

SOYBEAN SELECTING  
MACHINE

### <MAIN PRODUCTS>

- ★ Dryer  
(Paddy, Wheat, Soybean etc.)
- ★ Drying and Storage Bin
- ★ Seed Processing Plant
- ★ Pre-cleaner
- ★ Paddy Husking Machine
- ★ Rice Whitening Machine
- ★ Feed Cutter  
(Cylinder Type & Wheel Type)
- ★ Wood Chipping Machine
- ★ Soybean Processing Machine

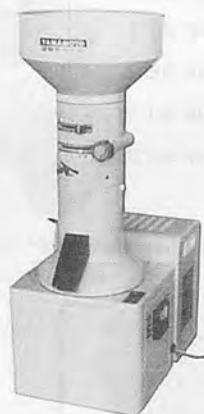

▲ TEST WHITENING MACHINE  
MODEL : VP-30T

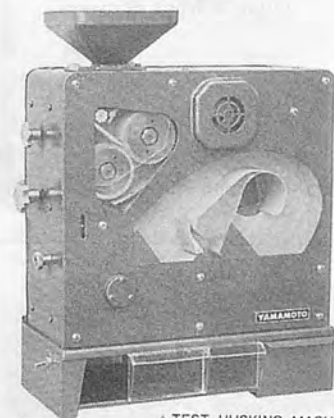

▲ TEST HUSKING MACHINE  
MODEL : TRH-16



## YAMAMOTO CO., LTD.

HEAD OFFICE & FACTORY: 404 OINOMORI, TENDO-CITY, YAMAGATA-PREF, JAPAN  
TELEX: 872266 YMCTNDJ TELEFAX: 0236-53-3411



# Fuji Robin's Agricultural Machinery

ADVANCE YOUR FARMING WITH  
VARIOUS ROBIN PRODUCTS!!

<p>Power Rotor</p> 	<p>PRO250 PRO270 PRO400 PR 500 PR 600 PR 750</p>	<p>Portable Tiller</p> 	<p>ST35</p>
<p>Power Tiller</p> 	<p>ST41 ST52 ST60 K1</p>	<p>Bush-cutter</p> 	<p>NB212 NB232 NB262 NB311 NBK231 NBK261</p>
<p>Dust &amp; Mist Blower</p> 	<p>NF211 NF352 NF412 NF512</p>	<p>Shoulder Type power Sprayer</p> 	<p>RS233 RS301 RS411 RS110</p>
<p>Portable Pump</p> 	<p>SDE041 SD08 SDY081 SDY201</p>	<p>Fire Pump</p> 	<p>P203 P206 P380 P408 P508 P570</p>



**FUJI ROBIN INDUSTRIES LTD.**

SHINJUKU-BLDG, 1-8-1 NISHI-SHINJUKU SHINJUKU-KU,  
TOKYO, JAPAN



# SHIBAURA

SHIBAURA'S SELECTED ENSURE YOUR VARIOUS WORKS EASY AND PRECISE WITH FULL ADVANCED TECHNOLOGY.



Small thru Big Sizes ....., Eased Works with Car-ride Feeling.

- Synchronmesh transmission and column shift employed.

Small and medium size tractors 14~50HP  
Big size tractors ..... 60~105HP



Lawn & Garden Tractor  
Model GT14 (14HP)



SHIBAURA Tillers, Everybody's Best from Home Gardening to Professional.

Compact and light weight crop security tillers. (2.0~7.0HP)

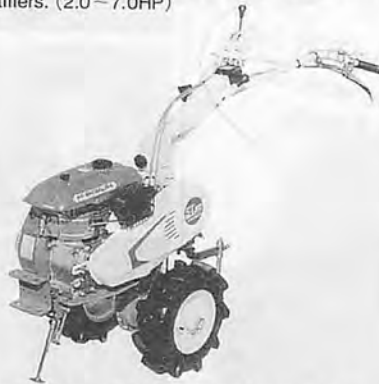

Durable and High Performance Self-Priming Pumps.

Delivery .....  
120~1,000ℓ/min.



Compact and Light Weight Make SHIBAURA Brush Cutters Easy in Operations.

- Fine start with solidstate magneto engines.
- Diaphragm carburetor employed.
- Antivibration kit ensures agreeable works. 0.55~2.0HP



Maintenance Free Portable Generator Series.

- Compact and light weight solidstate magneto engine installed.
- Field rotative and brushless type. 0.4~3.5KW



ISHIKAWAJIMA-SHIBAURA MACHINERY CO., LTD.

Head Office : 5-32-7 Sendagaya Shibuya-ku Tokyo Japan

Telephone : 358-4211 Telex : 232-2128

Cable Address : SHIBAURA TOKYO

ALL-PURPOSE MACHINERY FOR AGRICULTURE

# ASIA CULTIVATOR

ASIA CULTIVATOR  
Can be used for all -  
Purpose for farming of  
Vegetable, Horticulture  
and Greenhouse by Changing  
the attachments for  
Bed-Forming, Vinylon  
Mulching, Rotary Harrowing,  
Plowing, Weeding, Soil Piling  
and Ditching.

## ■ VARIOUS APPLICATION OF ASIA CULTIVATOR



One CULTIVATOR Can  
manage the work of  
40 men in 8 hours.



**A.I.C. MACHINERY CO., LTD.**

HEAD OFFICE ADD:220, NOWON-DONG, BOOKGU, DAEGU, KOREA.  
PHONE: (02) 547-9095, 8098 SEOUL, KOREA (053) 32-8111-7 DAEGU, KOREA. C.P.O BOX 5046 SEOUL, KOREA.  
TELEX: APCOSL K22969 FAX: (02) 547-0989 SEOUL KOREA, (053) 352-9863 DAEGU KOREA

# KIORITZ technology brings you a range of U.L.V. Sprayers for abundant harvests and a safe, comfortable environment.

By combining its long accumulation of chemical spraying technology with the latest concepts field, KIORITZ has developed a revolutionary U.L.V. (Ultra Low Volume) spraying system which is incorporated in its new line of U.L.V. Sprayers. Designed for both insect pest control and general agricultural spraying applications, these multipurpose machines offer unmatched versatility and safety for a wide range of spraying needs.

## HIGH-SPEED U.L.V. SPRAYER (TRUCK-MOUNTED TYPE) KM-500/KM-1000

This is a multipurpose sprayer ideal for general applications such as exterminating desert locusts and other insect pests, prevention of malaria, etc. The KM-500 is designed to be mounted on a pickup truck of 1-ton or larger capacity (1-ton class or higher in the case of a 4WD vehicle), while the KM-1000 can be mounted on a 2-ton or larger pickup truck (4-ton class or higher for a 4WD vehicle).



## U.L.V. NOZZLE DMULV-1 (Attachment for ECHO Duster/Mist Blowers & Power Blowers)

This high-performance

This high-performance U.L.V. nozzle can be attached to the ECHO range of Duster/Mist Blowers (DM-9, DM-3500, DM-4500, DM-5500, PB-4500) for environmental hygiene control such as malaria prevention, etc. as well as general-purpose applications.



## PNEUMATIC U.L.V. SPRAYER (BACKPACK TYPE) KP-140A

This compact and lightweight high-performance U.L.V. Sprayer can be employed for both environmental hygiene control such as malaria prevention, etc. and for general-purpose use.



KIORITZ CORPORATION has been strongly and actively engaged in O.D.A (official development assistance) projects supported and aided by the Japanese government.

You can never go wrong by using KIORITZ PRODUCTS.



# KIORITZ CORPORATION

7-2, SUEHIROCHO 1-CHOME, OHME, TOKYO, 198 JAPAN

PHONE:0428-32-6118 FAX:0428-32-6145 TELEX:2852070 KIORITZ-J

## **Niplo** AGRICULTURAL MACHINERY



We Look Forward To  
Extend Agribusiness  
With Global-Minded People.

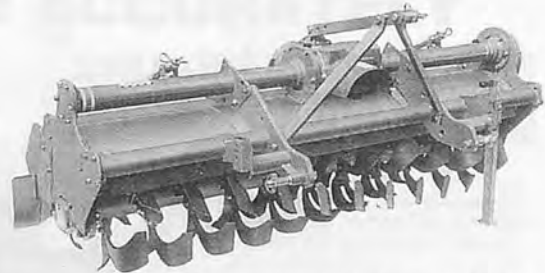

Model: DX-2000NA (70-100HP)

Main Niplo Products

- ROTARY TILLER
- DRIVE HARROW
- FLAIL MOWER
- DEEP ROTARY TILLER
- DIGGER

## **MATSUYAMA PLOW MFG. CO., LTD.**

Head Office & Factory: 2949, Shiokawa, Maruko-machi, Nagano-ken, 386-04, JAPAN

Telephone: Ueda (0268)35-0300 Telex: 3327589 NIPLOJ Fax: (0268)35-3231

# A line-up of superb, compact agricultural machines from OREC

HR660B  
HAMMER-ROTOR MOWER



GR530  
LAWN MOWER



AR700  
ACE ROTOR TILLER



You are proud to own the best.

OREC Mowers are designed for big-job performance and capacity.

OREC AGRICULTURAL MACHINES CO., LTD.

Head Office: 23-4 Jyojima-machi Mizuma-gun Fukuoka 830-02 Japan

Tel. 0942-62-3161~4

Telefacs 0942-62-6078

## YES! CANYCOM CAN CARRY ANY COMMUNICATION

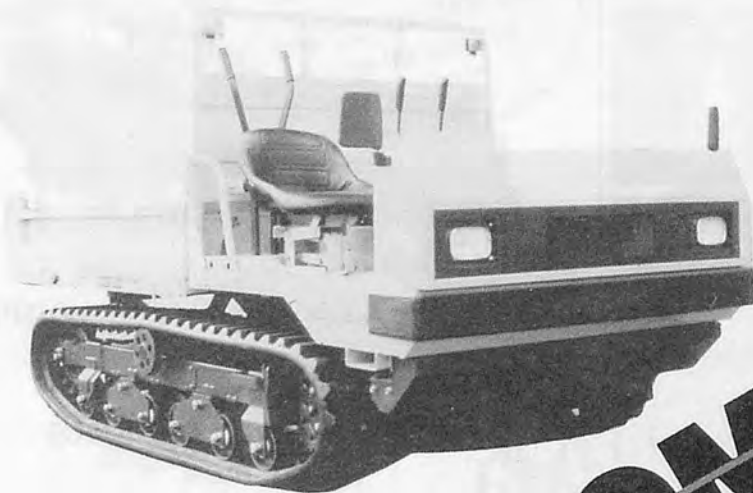

SE2301  
2,000KG (PAYLOAD)  
23HP (MAX)



BFP402  
300KG (PAYLOAD)  
4HP (MAX)

# CANYCOM

TRANSPORT CREATOR

## CHIKUSUI CANYCOM, INC

ATO BUILDING 307, 1-2-7 SHIBA DAIMON MINATOKU TOKYO 105, JAPAN TEL(03)3433-4900, FAX(03)3433-0663



# KOBASHI

## PADDY HARROW



\$\$ FOR THE PURPOSE OF KEEPING HIGH QUALITY GRAIN \$\$  
 \$\$ FOR THE PURPOSE OF SAVING SEED COST \$\$  
 WITH ONE OPERATION AFTER TILLING THE FIELD WILL  
 BECOME FLATLY HORIZONTAL

MODEL: PHN282 PHN322 PHN342 PHN362  
 KOBASHI PHN322



**KOBASHI**  
 KOBASHI KOGYO CO., LTD.  
 684, Nakaune, Okayama City, Japan  
 Phone: 0862(98)3111  
 Telex: 5922188 KBSOKA J

KOBASHI

## SINGLE KERNEL MOISTURE CAN BE ANALYZED ACCURATELY

SINGLE KERNEL MOISTURE TESTER

**CTR-160A**

- Object: Corn, Soybean, etc.
- Moisture range: Corn, Soybean (9-40%)
- Accuracy:  $\pm 0.5\%$  (moisture 11.0-25.0%)



SINGLE KERNEL MOISTURE TESTER

**CTR-800A**

- Object: Paddy, Brown rice, Wheat, Barley
- Moisture range: Paddy (9.4-Approx. 40%), Brown rice (9.8-Approx. 45%), Wheat (9.2-Approx. 45%), Barley (9.0-Approx. 45%)



Conventional moisture testers show only average moisture content of the sample. This single Kernel Moisture Tester finds out moisture dispersion and also average moisture content. It has wide application for standing crops, grains before, during and after the drying process.

## SHIZUOKA SINGLE KERNEL MOISTURE TESTER

SHIZUOKA SEIKI CO., LTD.

4-1 YAMANA, FUKUROI, 437 JAPAN FAX: 81-538-42-5699



# YANMAR

## DIESEL POWER TO PLOW LIFE INTO LANDS



Diesel Tractor 12.5~97hp

### Yanmar power. It works for you in many better ways.

Across vast stretches of the world where terrain and weather combine against agriculture, Yanmar's rugged machinery is working on the side of the farmer. Built from generations of

experience in fieldwork this equipment has a natural ability and durability that few other agricultural machines possess. It is designed to give the farmer the advantage of modern efficiency in his fight to claim the land for his crops.



Diesel Power Tiller

YT series 4~6hp

YTA series 5~6.7hp

YZA series 8.5~12.5hp



Rice Huller/Polisher

YHP800 800~900kg/hr



Combine Harvester

CA series 7.5~73hp

### YANMAR AGRICULTURAL EQUIPMENT CO.,LTD.

1-32, Chayamachi, Kita-ku, Osaka 530, Japan Telex: 5233623 YMR AGJ Telephone: 06-376-6336 Facsimile: 06-373-9474

# AMMA

**AGRICULTURAL MECHANIZATION IN ASIA, AFRICA AND LATIN AMERICA**

VOL.22, NO.1, WINTER 1991

*Edited by*

**YOSHISUKE KISHIDA**

*Published quarterly by*

**Farm Machinery Industrial Research Corp.**

*in cooperation with*

**The Shin-Norinsha Co., Ltd.**

**and**

**The International Farm Mechanization Research Service**

**TOKYO**

Yoshisuke Kishida, Publisher & Chief Editor

Contributing Editors and Cooperators

**- AFRICA -**

Baryeh, Edward A. (Cameroon)  
El Hossay, A.M. (Egypt)  
Pathak, B.S. (Ethiopia)  
Ampratwum, David Boakye (Ghana)  
Bani, Richard Jinks (Ghana)  
Djokoto, Israel Kofi (Ghana)  
Some, D. Kimutaiarap (Kenya)  
Choudhury, Md. Shahansha Uddin (Nigeria)  
Igbeka, Joseph C. (Nigeria)  
Odigboh, E.U. (Nigeria)  
Oni, Kayode C. (Nigeria)  
Kuyembeh, N.G. (Sierra Leone)  
Abdoun, Abdien Hassan (Sudan)  
Saeed, Amir Bakheit (Sudan)  
Eldin, Eltag Saif (Sudan)  
Khatibu, Abdissalam I. (Tanzania)  
Tembo, Solomon (Zimbabwe)

**- AMERICAS -**

Nääs, Irenilza de Alencar (Brazil)  
Ghaly, Abdelkader E. (Canada)  
Valenzuela, A.A. (Chile)  
Mirdha, A.H. (Mexico)  
Ulloa-Torres, Omar (Mexico)  
Chancellor, William J. (U.S.A.)  
Goyal, Megh Raj (U.S.A.)  
Philips, Allan L. (U.S.A.)

**- ASIA and OCEANIA -**

Farouk, Shah M. (Bangladesh)  
Mazed, M.A. (Bangladesh)  
Wang, Wanjun (China)  
Chandra, Satish (Fiji)  
Michael, A.M. (India)  
Mittal, J.P. (India)  
Ojha, T.P. (India)  
Verma, S.R. (India)  
Soedjatmiko (Indonesia)  
Behroozi-Lar, Mansoor (Iran)  
Sakai, Jun (Japan)  
Snobar, Bassan A. (Jordan)  
Chung, Chang Joo (Korea)  
Lee, Chul Choo (Korea)  
Haffar, Imad (Lebanon)  
Bardaie, Muhamad Zohadie (Malaysia)  
Afzal, Mohammad (Pakistan)  
Chaudhry, Allah Ditta (Pakistan)  
Chaudhry, Md. Siddique (Pakistan)  
Devrajani, Bherulal T. (Pakistan)  
Mughal, A.Q. (Pakistan)  
Nath, Surya (Papua New Guinea)  
Lantin, Reynaldo M. (Philippines)  
Venturina, Ricardo P. (Philippines)  
Aziz, M.H. Abdel (Saudi Arabia)  
Illangantileke, S. (Sri Lanka)  
Kathirkamathamby, Suppiah (Sri Lanka)  
Chang, Sen-Fuh (Taiwan)  
Rojanasaroj, C. (Thailand)  
Singh, Gajendra (Thailand)  
Pinar, Yunus (Turkey)

**- EUROPE -**

Kaloyanov, Anastas P. (Bulgaria)  
Have, Henrik (Denmark)  
Pellizzi, Giuseppe (Italy)  
Wanders, A. Anne (Netherlands)  
Kilgour, John (U.K.)

**EDITORIAL STAFF**

(Tel. 03/291-5718)

Yoshisuke Kishida, Chief Editor  
Kensuke Sakurai, Managing Editor  
Yoshinori Sasaki, Assistant Editor  
Noriyuki Muramatsu, Assistant Editor  
D.A. Cruz, Editorial Consultant

**ADVERTISING**

(Tel. 03/291-3672)

Kuniharu Ikeda, Manager (Head Office)  
Hiroshi Yamamoto, Manager (Branch Office)  
*Advertising Rate: 300 thousand yen per a page*

**CIRCULATION**

(Tel. 03-291-5718)

Soichiro Fukutomi, Manager  
Editorial, Advertising and Circulation Headquarters  
7, 2-chome, Kanda Nishikicho, Chiyoda-ku, Tokyo, 101, Japan

Copyright © 1991 by

**FARM MACHINERY INDUSTRIAL RESEARCH CORP.**  
SHIN-NORIN Building  
7, 2-chome, Kanda Nishikicho, Chiyoda-ku, Tokyo 101 Japan  
Printed in Japan

This is the 70th issue since the issue, Spring of 1971

## EDITORIAL

### 1991 and Beyond

As this Winter issue of the AMA goes to the press, we at the AMA staff wish its readers, contributors, friends and other clients a VERY PROSPEROUS AND PEACEFUL NEW YEAR!

In extending this Season's Greetings, we continue to pray hard that military forces do not clash in the Gulf after that January 15 deadline given by the United Nations to Iraq's President Saddam Hussein to pull out from Kuwait. For, if war should ever break out, God forbid, the net result would indeed be very frightening as the aftermath, in death and destruction, could very well exceed those seen in the last two world wars. Therefore, let there be peace instead of war after January 15 and beyond.

We in the agricultural machinery business are an optimistic lot. Like farmers everywhere, we like to look ahead beyond 1991 with hopes and prosperity, peace and happiness that are achievable only sans war. Throughout history, farmers have never been known to initiate war by choice. Rather, they link people around the globe through peaceful and constructive work. They toil unceasingly in order that food may be harvested from the soil in abundance so that hunger may be averted, so that tension between countries that have plenty and those that have less may be reduced, and so that peace may prevail.

It is indeed in this light that the AMA continues to promote mechanization world-wide—to be of some help to the farmers to improve their productivity through the use of modern means of production, i.e., farm machineries.

As the New Year is ushered in, the AMA once more makes a firm resolve to strive to promote agricultural mechanization by working hand-in-hand with our co-editors, readers and clients. This is our mission in 1991 and beyond.

Here's wishing everyone a peaceful 1991!

Yoshisuke Kishida  
Chief Editor

Tokyo  
January, 1991

# CONTENTS

## AGRICULTURAL MECHANIZATION IN ASIA, AFRICA AND LATIN AMERICA

Vol. 22, No. 1, Winter 1991

Yoshisuke Kishida	13	Editorial
Yasuo Shibata	15	Development of Load Cell of Tension and Compression Type by Appropriate Technology
Kiyohiko Toyoda	21	Feasibility of Using Field Plot Machinery in India
B.G. Yadav	26	Testing and Evaluation of Fuel Filters Used on Tractors
R.N.S. Yadav	29	Field Performance Evaluation of Bullock-drawn Puddler
A.K. Singh	34	Power Requirements of Tillage Implements
M.L. Mehta	39	Design, Development and Evaluation of Power Tiller-drawn Seed-cum-Fertilizer Drill
R. Tiwari	42	Small Power Unit, Equipment and Service Units—Needs, Structures and Problems
D.N. Sharma	45	Development of a Low-cost Weeder for Lowland Paddy
M.L. Jain	49	Energy Studies in Cropping Systems in Lateritic Soil of Orissa, India
S.C.L. Premi	53	Rice Post-harvest Practices and Loss Estimates in Bangladesh: Threshing through Sundrying
Jan Md. Baloch	59	Energetics of Forage Chopping
Shah Nawaz Mirani	64	Mango Harvesting Techniques in Bangladesh
Ali Nawaz Mirani	69	Agricultural Mechanization in Rajasthan, India
Sheruddin Bukhari	73	Fog Emitters as Evaporative Cooling Devices for Dairy Cow Sheds
A.C. Varshney	77	The Present State of Farm Machinery Industry
C.P. Bohra	81	Outline and Activities of National Agriculture Research Center
S. Narang	86	Prospect of Agricultural Machinery Course in Hokkaido University
Lozan G. Stoimenov	89	Research and Education of The University of Tsukuba
Md. Syedul Islam	91	Introduction of Agricultural Machinery Laboratory, Department of Agricultural Engineering, Kyushu University
Khondaker Azharul Haq	96	Introduction of Japanese Society of Agricultural Machinery
P.K. Mohapatra	99	Activities by Hokkaido Agricultural Machinery Association
P.C. Senapati	101	Main Products of Agricultural Machinery Manufacturers in Japan
D. Satpathy		
A.K.M. Anwarul Haque		
N.H. Choudhury		
M.A. Quasen		
Jose R. Arboleda		
Yumnam Jekendra		
Pratap Singh		
Daulat Hussain		
Murshed Alam		
Md. Akhtar Hussain		
Ajay Kumar Sharma		
Abdelhafeez M. Abdalla		
R. Narendran		
Farm Machinery Industrial Research Corp.		
Takashi Kuwana		
Hokkaido University		
Toshio Konaka		
Jun Sakai		
Toshio Konaka		
Nobuhito Murai		
Shin-Norinsha Co., Ltd.		

News	106
Book Review	110

Instructions to AMA Contributors	111
Co-operating Editors	112

Back Issues	114
-------------	-----

# Development of Load Cell of Tension and Compression Type by Appropriate Technology



by  
**Yasuo Shibata**  
Expert of Japan International Cooperation Agency  
Jomo Kenyatta University  
College of Agriculture and Technology  
Nairobi, Kenya



**Kiyohiko Toyoda**  
Asst. Prof.  
Dept. of Agric. Engg.  
Kobe Univ.  
Kobe, Japan

## Abstract

Introduced here is a load cell which is a measuring device for both tension and compression forces. This load cell can be manufactured in many countries relatively easily by an ordinary lathe and a milling machine without special materials and heat treatment. It will be a useful equipment for research and development (R & D) work in agricultural machinery because external forces which are acting on various portions of agricultural machinery can be measured fairly precisely by this load cell.

Effective experimental work on agricultural work will be also achieved by this load cell for students of mechanical and agricultural engineering.

## Introduction

Development work on agricultural machinery is being done not only in developed countries but also in many developing countries.

**Acknowledgements:** The authors are very much indebted to Japan International Cooperation Agency (JICA) and JICA personnel concerned for the financial support and encouragement. The authors are also very grateful to Prof. Jun Sakai of Kyushu University for various valuable advice.

In some countries, especially newly-industrialized countries (NICs), agricultural machinery of high technical standards are being produced. On the other hand, there are still many countries which have not yet obtained adequate development ability in the manufacture of agricultural machinery.

There are several stages in the development of agricultural machinery. In the first stage, the main work is to develop a machine which is equipped with the minimum required functions for farm work. In this stage the machine might be manufactured in small scale and have not a few points to be improved. In the second stage much efforts are exerted in improving the developed machine. The machine might be more satisfactory to users and the manufacturing scale might be bigger than the first stage. In the third stage the machine is much more improved and sophisticated. It is already good for big scale production and will be exported to foreign countries.

As the development work becomes higher in quality, more scientific and rational design is necessary. Exact estimation of external forces imposed on the machine is important work to be done in such a higher development

stage because the design is considerably influenced by the external forces which might act on the machine. Similarly, in higher education, this kind of measurement will help students to understand agricultural machinery deeply.

The measurement of external forces, however, is not easy. Various expensive equipment are necessary for accurate measurement of external forces. In reality, however, accurate measurement of external forces is not very popular, specially in developing countries.

A load cell is a sensing device in an electronic force measuring system which is popular in developed countries but not in developing countries. High level manufacturing technology required for the load cell and the high cost seem to be the bottlenecks for the popularization. Therefore, the authors started to design a simpler and less expensive load cell which can be manufactured easily in developing countries and can be widely applicable to R & D work and educational activities. The design was done in order that the load cell may meet the following conditions:

- 1) The load cell can pick up both tension and compression forces with precision;
- 2) The material should be easily

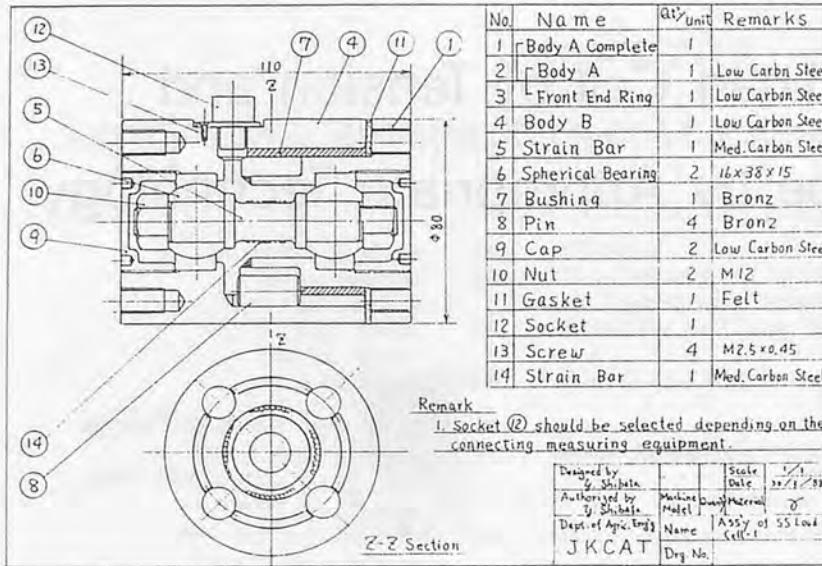

Fig. 1 Load cell assembly.



Fig. 2 Developed load cell and parts.

available in developing countries;

- 3) The load cell should be simple enough to be manufactured easily with ordinary machining skill; and
- 4) The load cell should be as compact as possible.

A strain bar type load cell with flanges in both ends was selected to meet the above conditions. For the load cell, two spherical bearings which are products of developed countries were used to meet to conditions 1) and 4), though they might be less easily available than others in some countries.

### Design and Manufacture of Load Cell

#### General Structure

As the load cell should be able to detect tension and compression in one direction, thorough consideration is required in the design of the structure.

Principally, it will be realized by the layout of strain gauges that bending moment and torsion may be applied only to the main bodies and not to the strain bar. However, it is not possible to put all the strain gauges exactly on the right positions and eradicate

manufacturing tolerances of all the parts. Therefore, it is necessary to minimize structurally bending moment and torsion which might be applied on the strain bar. Considering these conditions, the load cell was designed (Figs. 1 and 2). This might be called a strain bar type load cell and is divided into three portions: strain bar, bearings and main bodies.

#### Basic Principle of Load Cell

When a tension or a compression force is applied on the load cell, a strain is produced on the strain bar. If a strain gauge is put on the strain bar, a change in electric resistance  $\Delta R$  is sensed by the strain gauge as follows:

$$P/R = k\epsilon \quad (1)$$

where, R = electric resistance of the strain gauge

$\epsilon$  = strain of the strain gauge

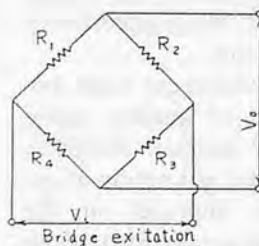

Fig. 3 Wheatstone bridge circuit.

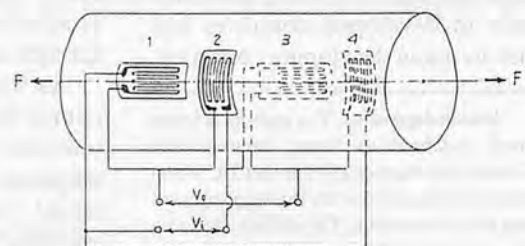

Fig. 4 Layout of strain.

$k$  = strain sensitivity

As  $\Delta R$  is usually very small, a Wheatstone bridge is used to pick it up as shown in Fig. 3. All the four resistances,  $R_1$  to  $R_4$  in the circuit, are usually the same and at least one of the bridge arms is composed of the strain gauge.

According to the circuit theory, the following equation is easily obtained.

$$V_o = \frac{1}{4} \left( \frac{\Delta R_1}{R_1} - \frac{\Delta R_2}{R_2} + \frac{\Delta R_3}{R_3} - \frac{\Delta R_4}{R_4} \right) \quad (2)$$

By substituting (1) into (2), we obtain,

$$V_o = \frac{K}{4} (\epsilon_1 - \epsilon_2 + \epsilon_3 - \epsilon_4) V_i \quad (3)$$

Here, we define,

$$\epsilon_m = \epsilon_1 - \epsilon_2 + \epsilon_3 - \epsilon_4 \quad (4)$$

Then, (3) is rewritten in the following manner.



$$\epsilon_m = 4V_o/kV_i \quad (5)$$

If the same four strain gauges are put on the strain bar as shown in Fig. 4, with R<sub>1</sub> and R<sub>3</sub> in the direction of force and R<sub>2</sub> and R<sub>4</sub> in the direction perpendicular to the force, the strain in each gauge is as follows:

$$\epsilon_1 = \epsilon_3 = \epsilon_b \quad \epsilon_2 = \epsilon_4 = -\nu\epsilon_b \quad (6)$$

where,  $\epsilon_b$  : strain of the strain bar in the direction of the force.

$\nu$  : Poisson's ratio of the strain bar

From (4) and (6), we obtain,

$$\epsilon_m = 2(1 + \nu)\epsilon_b \quad (7)$$

Equation (7) shows that by the layout of the strain gauges as in Fig. 4, the measured strain  $\epsilon_m$  is 2(1 +  $\nu$ ) times as big as  $\epsilon_b$ . This equation is important to check the calibration result. By substituting (5) into (7), we obtain,

$$\epsilon_b = 2V_o/(1 + \nu)kV_i \quad (8)$$

Equation (8) shows that if the output voltage  $V_o$  is measured, the strain of the strain bar can be estimated with the knowledge of  $\nu$ ,  $k$  and  $V_i$ .

If a force  $F$  is applied to the load cell, the axial stress on the strain bar  $\sigma_b$  and the strain  $\epsilon_b$  are expressed by the formulas.

$$\sigma_b = F/A = E\epsilon_b$$

$$\epsilon_b = F/AE \quad (9)$$

where,  $E$  = Young's modulus.

$A$  = Area of the section of the strain bar

Substituting (9) into (7), we obtain,

$$\epsilon_m = 2(1 + \nu)F/AE \quad (10)$$

or,

$$F = AE\epsilon_m/2(1 + \nu) \quad (11)$$

Equation (11) shows the relation between the force and the measured strain.

### Strain Bar

There are some conditions which the strain bar must meet. They are as follows:

- Uniform stress should be produced on the strain gauge;
- Stress and strain should be within the limit of proportionality;
- Easy to put strain gauges on;
- Easy to manufacture; and
- Compact.

In order to meet the above conditions, a strain bar was designed (Fig. 5). This can be machined easily by an ordinary lathe. Medium carbon steel was selected for the strength. The diameter was determined on the conditions of b) and c). From condition b), the following equation is derived.

$$\sigma_p \geq n\sigma_{max} = 4nF_{max}/\pi d^2 \quad (12)$$

where,  $\sigma_p$  = stress on the limit of proportionality,  
 $n$  = safety factor,  
 $d$  = diameter of the strain bar.

From (12), we obtain,

$$d \geq \sqrt{\frac{4nF_{max}}{\pi\sigma_p}} \quad (13)$$

If  $F_{max} = 1500N$ ,  $\sigma_p = 200N/mm^2$ ,  $n = 2$ , then we obtain,

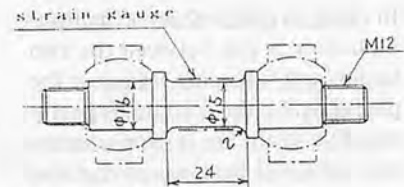

Fig. 5 Strain bar.

$$d \geq 13.8 \text{ mm}$$

Taking it into consideration that strain gauges should be easily fixed to the bar, the diameter was determined as follows:

$$d \geq 15.0 \text{ mm}$$

As the sensing portion of the strain bar should be long enough for uniform stress distribution and for the strain gauge which is usually 10 to 12 mm in length or in diameter, the straight portion of the bar was decided to be 20 mm in length. This portion was ground for fixing strain gauges. The radius of the corners should be large enough to reduce the stress concentration and was determined to be 2 mm.

### Main Bodies and Bearings

It is necessary that the two bodies which support the strain bar slide to each other in the axial direction but not rotate relatively.

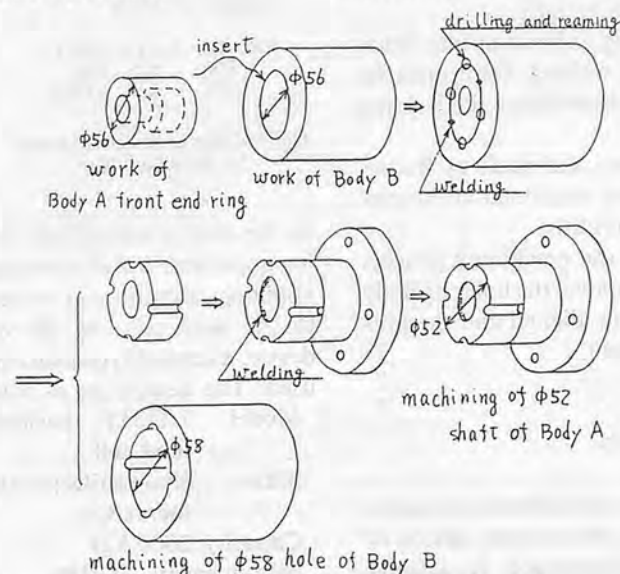

Fig. 6 Manufacturing process of Body A and B.

In order to realize this mechanism, a bushing is put between the two bodies and four pins are put at the places where the bushing is partly cut. The strain bar is supported by two spherical bearings so that the outer races of the bearings may rotate a little and no stress may be applied to the strain bar. The spherical bearing was chosen due to the relatively high axial load capacity and its compactness. The lateral sides of the spherical bearings are supported by caps through which compression force is transmitted to the strain bar.

Machining of the bodies can be done by an ordinary lathe and a vertical milling machine. However, machining of the holes for four pins of the two bodies should be done together to obtain high accuracy. This will be done in the following order as shown in Fig. 6.

- 1) Machining of Body A front end ring;
- 2) After inserting the ring into the work of Body B, temporary welding should be done. Then  $\phi 12$  holes are drilled and reamed by a vertical milling machine;
- 3) Take out the ring from Body B and remove the unnecessary portion by lath.
- 4) The ring is inserted into Body A and welded. Care must be taken to minimize the welding strain.
- 5) The hole and shaft of Bodies A, B are machined accurately and smoothly.

Due to the machining process described above, the holes of Body A and B are aligned and the pins function well.

### Calibration

In order to calibrate a measuring device, an accurate device of which performance is already known is requisite as the datum.

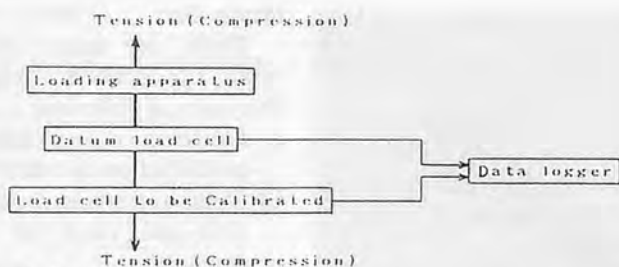

Fig. 7 Calibration system.

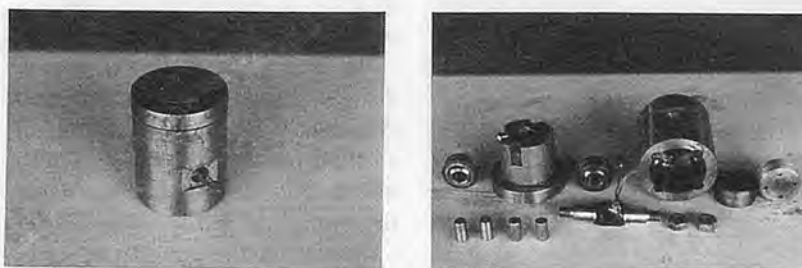

Fig. 8 Calibration of the load cell.

**MEASURE** REP-01			
(DATE) 1988-09-26			
(TIME) 15:52:24			
ER	CH.	DATA	UNIT
	000	508	Kgf
	001	343	STRN
**MEASURE** REP-01			
(DATE) 1988-09-26			
(TIME) 15:52:51			
ER	CH.	DATA	UNIT
	000	703	Kgf
	001	476	STRN
**MEASURE** REP-01			
(DATE) 1988-09-26			
(TIME) 15:53:19			
ER	CH.	DATA	UNIT
	000	923	Kgf
	001	629	STRN

Fig. 9 Calibration data recorded by the data logger.

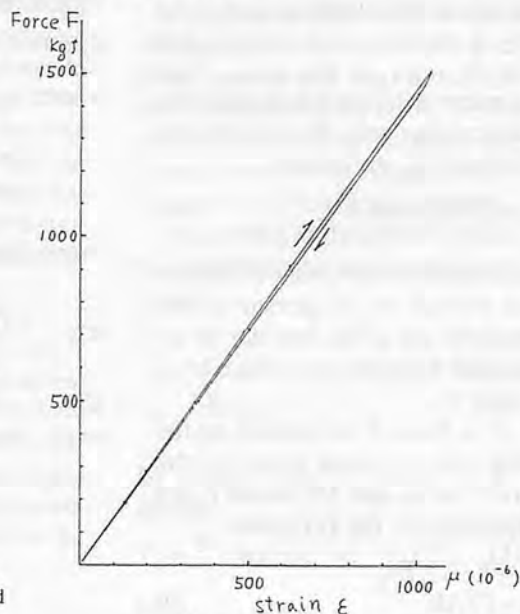

Fig. 10 Calibration graph.

In the case of a load cell, a loading apparatus is also necessary for applying compression or tension to the load cell. As the datum device, a tension type load cell was used. The details are as follows:

Model	LT-2TF, tension type load cell
Make	Kyowa Electric Instruments Co.
Capacity	2000 kgf
Non-linearity	0.01%
Hysteresis	0.05%

To apply tension force, a crane on the ceiling and a T-shaped groove on the floor were used. In between the two, the load cell to be calibrated, the datum load cell and a hoist were inserted. A digital data logger, UCAM-2B was connected to them. This calibration system is shown in Figs. 7 and 8.

The tension force was increased from zero to about 1500 kgf step by step and the load on the two

load cells were recorded by the data logger. The calibration was achieved by comparing the data recorded as in Fig. 9.

The data were plotted on a graph as shown in Fig. 10. The strain and force were expressed on the horizontal and vertical axes, respectively. The linear relation was obtained with nonlinearity of 0.5%. This linear relation will be expressed as follows:

$$F_i = m \epsilon_i$$

where,  $F_i$  = measured force in kgf  
 $\epsilon_i$  = measured strain in micron,  $10^{-6}$ .

The inclination of the straight line  $m$  is obtained by the following equation.

$$m = \sum \epsilon_i F_i / \epsilon_i^2$$

The calculated value of  $m$  was:

$$m = 1.46 \text{ kgf}/\mu$$

By substituting  $A = \pi \times 15^2 / 4 \text{ mm}^2$ ,  $E = 2.1 \times 10^4 \text{ kgf}/\text{mm}^2$ ,  $\nu = 0.3$ ,  $\epsilon_m = 10^{-6}$  into (11), we

obtain,

$$F = AE \epsilon_m / 2 (1 + \nu) = \pi \times 15^2 \times 2.1 \times 10^4 \times 10^{-6} / 4 \times 2 (1 + 0.3) = 1.43 \text{ kgf}$$

The difference between the two figures would be caused mainly by inaccurate estimation of  $E$  and  $\nu$ . As it is a small value of about 2% of  $m$ , the performance was almost similar (as was expected).

Hysteresis of 2.5% was observed. Though this is not negligibly small, reducing the hysteresis will be possible by better machining and surface finishing.

## Application of Load Cell

The developed load cell is widely applicable to various research and educational activities. Basically, wherever there is room for inserting the load cell in a machine, the force imposed on it can be measured. Some examples of measuring force by the load cell are listed below and in Fig. 11.

- 1) To study the performance of implements for tractors through measurement of three-point linkage forces;
- 2) Measurement of various linkage forces of implements;

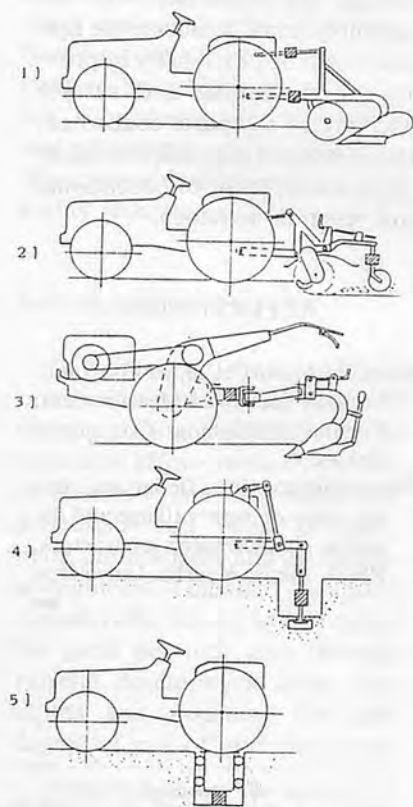
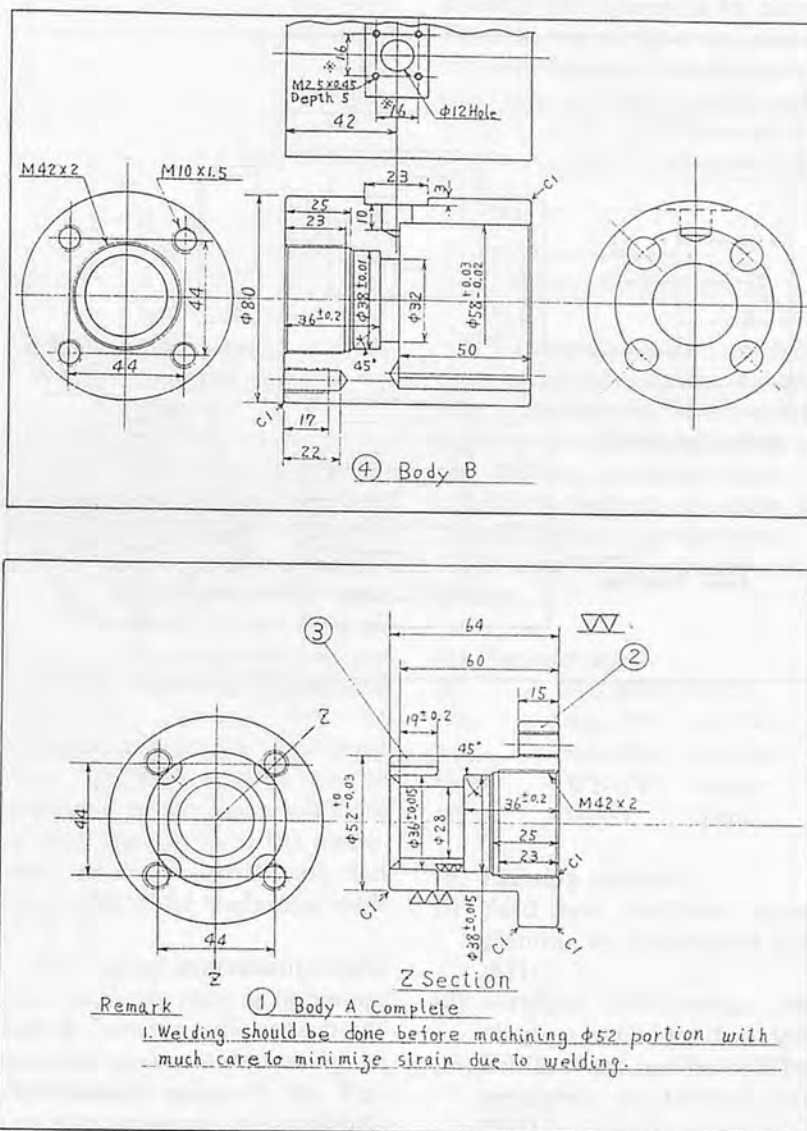
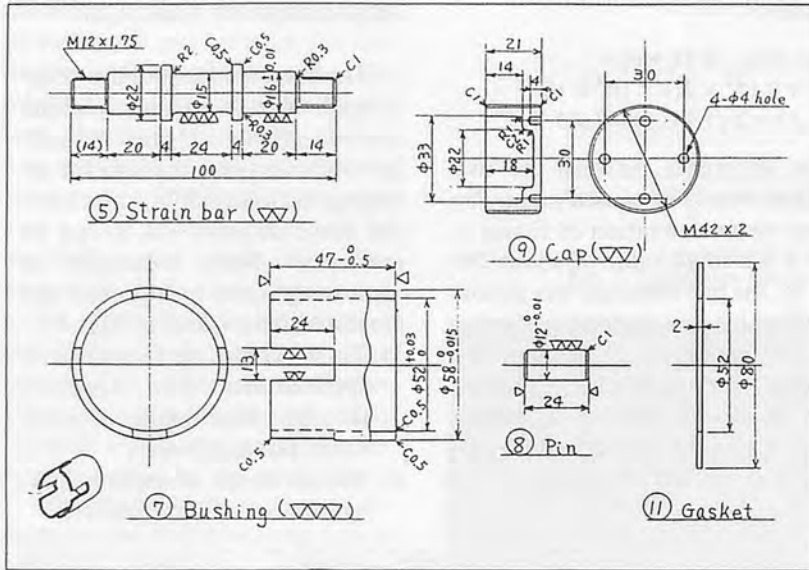

Fig. 11 Example applications of the developed load cell.





- 3) Measurement of the force on hand tractor hitch by inserting the load cell between the hitch and implements;
- 4) Measurement of the lifting force of a tractor; and
- 5) Measurement of weight of agricultural machinery.

These are only some examples of the load cell applications. If the developed load cell is utilized effectively, research and educational activities will be widened considerably.

### Conclusions

A load cell for measuring tension and compression was developed based on ordinary machining skill and relatively easily available materials in any country. Linear characteristic which is requisite for a measuring device was obtained as was expected, though the hysteresis was not negligibly small. Reducing the hysteresis will be possible by improving the machining and surface finishing of the parts concerned. The developed load cell is applicable to a wide range of educational and research activities.

### REFERENCES

- Masaichi Matori et al, 1957, Handbook of Industrial Measurement, Corona Publishing Co., Ltd., Tokyo.
- Yasuo Shibata. 1981, Design engineering study on rotary tillage and dynamic characteristics of tractors, Ph.D. thesis, Kyushu University.

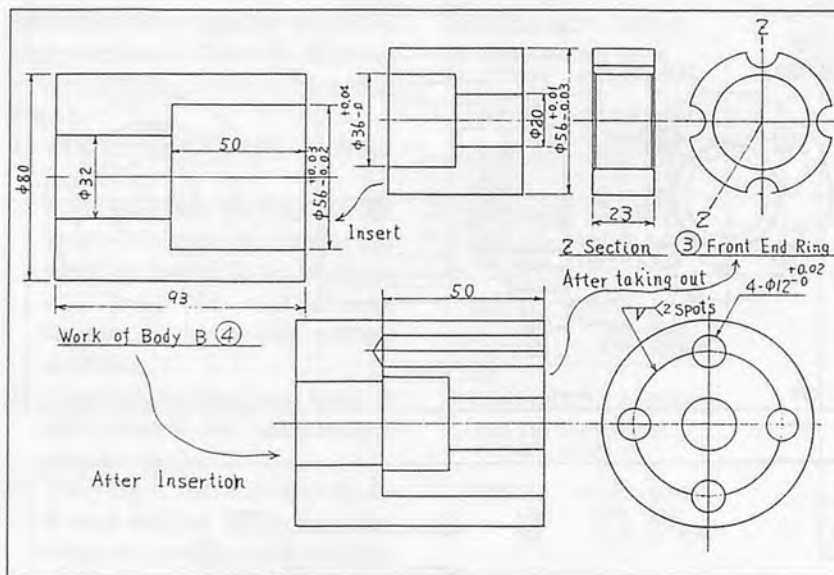

# Feasibility of Using Field Plot Machinery in India

by  
B.G. Yadav  
Doctoral Student  
Agric. and Food Engg. Dept.  
Asian Institute of Technology  
Bangkok 10501  
Thailand



R.N.S. Yadav  
Senior Scientist  
Crop Prod. Engg. Div.  
Central Inst. of Agric. Engg.  
Nabi Bagh, Berasia Road  
Bhopal, India

## Abstract

Bio-scientists in the country, for the present, rarely use agricultural machines in their experiments mainly due to their inaccuracy. The machines with desired accuracy are rare or not available. The experimental plot machines procured from abroad were evaluated and few were found suitable for the Indian situations, hence have potentials for use. Considering the specific uses and advantages, the development of such machines indigenously was highly recommended.

## Introduction

In India today, the rate of food production is matching well with the population growth due to the consistent efforts made by the bio-scientists like agronomists, genetisists and plant breeders, plant physiologists and agricultural engineers. Together, they have considerable impact in increasing the yield per unit area through varietal development using high inputs and assuming the high degree of risk of imported varie-

**Acknowledgement:** The authors are grateful to the Director of the Central Institute of Agricultural Engineering, Bhopal, for procuring these experimental plot machines and facilities for the study.

tal technology (1, 3, 4). The yield potential of most crops has more or less stagnated. It is estimated that India requires 250 million tons of food grains by 2000 AD to meet the needs of her growing population.

There are many state agricultural universities and ICAR institutions with many affiliated research stations. There are 27 state agricultural universities and 38 ICAR institutes and 70 All-India coordinated schemes with over 200 research centres. In all, there are 1209 research centres in the country engaged in crop-based agricultural researches. It has been noticed that even on these research centres the experimental plot machines are not in use (4). Even many of these organizations are not using improved agricultural equipment. Instead they use manual methods and traditional tools. The basic reasons may be attributed to the non-availability of field plot machines, less awareness on the farmers' part and inaccuracy of the traditional tools (2, 4, 5).

The use of experimental field plot machinery plays an important role in increasing the capacity of research work and decreasing the experimental errors (1, 2). This can also accelerate the availability of research findings of various

research institutions to its users. Thus the use of the experimental field plot machinery on the experiment may contribute considerably in pushing the yield towards the genetic maximum potential of the crop (2).

## Experimental Method

The experiment was planned keeping in view the sizes of available machines and their possible adjustments so that full width of the different machines could be effectively utilized in single or multiple passes over the plots.

The detail of experiments are as follows;

### (a) Varieties tried

- (i) HD 4530 JS-2
- (ii) Raj-1555 JS-7244
- (iii) Sonalika Punjab-1
- (iv) WH-147 Ankur
- (v) Lok-1 Black

### (b) Planting method

- (i) Seed and fertilizer mixed planting by Oyjord plot drill (M1)
- (ii) Fertilizer broad-casted and planting by Oyjord drill (M2)
- (iii) Fertilizer and seed both drilled separately by Oyjord drill (M3)

- (c) Experimental details  
 Replications 4 m  
 Plot sizes 20 m × 3.15 m  
 Row spacings  
     22.5 cm (wheat)  
     45 cm (soybean)  
 No of rows on the machine  
     7 (wheat) 4 (soybean)

The experiments were conducted in Rabi (Oct.-Dec.) on wheat and Kharif (Jun.-Aug.) on soybean. The detail of the experimental plan is shown in Fig. 5. Since 3.15 m plot width was covered in two planting operations, the seed and fertilizer were equally divided in 120 parts as per the predetermined rates. Fertilizer and seeds were drilled as per the plan (Fig. 5) in the field. As the maturity time of most soybean varieties are different, a split plot design was used to facilitate the combine use and also to avoid the shattering caused due to delay in harvesting but the wheat was drilled randomly. Seeding was done in all the plots by using the Oyjord plot drill non-stop and no-grain mixing was noticed. On the average, the machine took 3 min to plant each plot (63 mxm) and practically it did not take any time to change the variety as it was achieved simply by actuating a lever while the machine was on the move. Each plot was separated by 1 m spacing to avoid overlapping of seeding on plots. Plant counts were recorded after the seed emergence and first irrigation until the tillering initiated in wheat.

The following machines were evaluated in actual field conditions as per the agronomical trials;

### Oyjord Plot Drill

The Oyjord plot drill (Fig. 1) has provisions for sowing the seeds continuously. In addition, it has special provisions for varying the plot length between 6-22.5 m with the help of a variator which is the special need in experiment. The

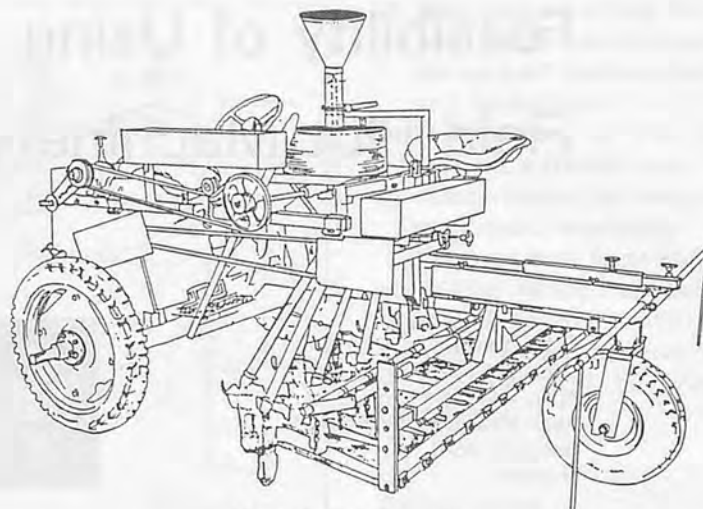

Fig. 1 Oyjord plot drill.

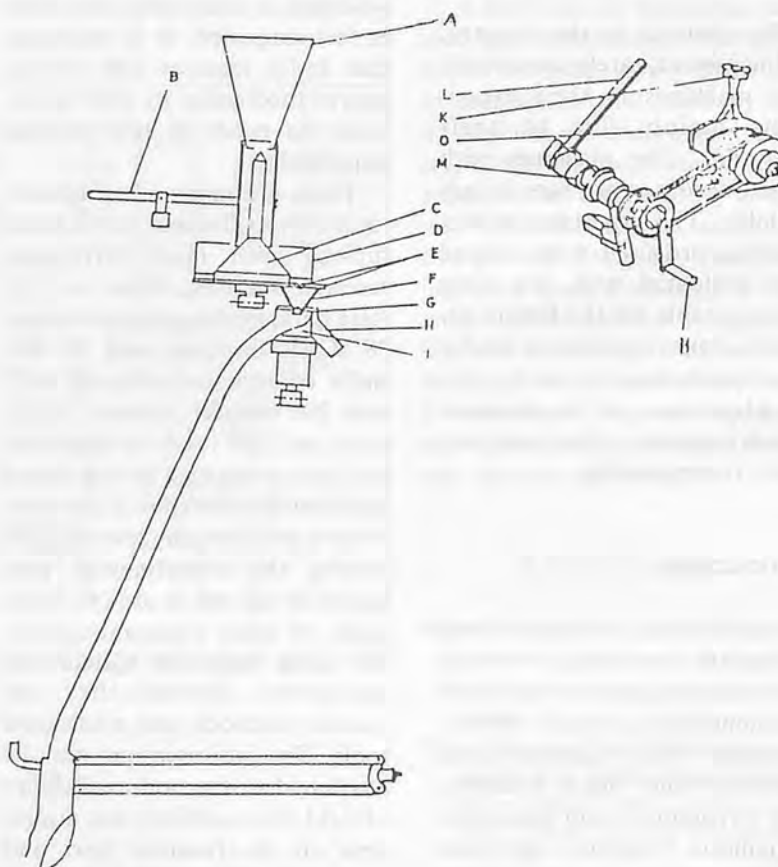

Fig. 2 Seed metering system on Oyjord plot drill.

Oyjord system is shown in Fig. 2. The basic concept of the Oyjord system is star feeder (D), which continuously feeds on rotating distributor (I) for equal distribution of materials in the seed tubes. The exact quantity of seed can be put

in the funnel (A) which rests over the cone (C). In conjunction with the plot length when lever (B) is actuated the seeds get uniformly distributed in all the cells of the distributor.

During the operation of the

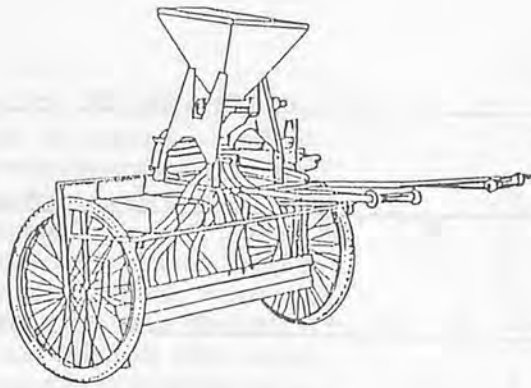

Fig. 3 Fertilizer distributor, Hege-33.

machine, the star feeder rotates and the individual cell pushes the seed in the slit (E) and seed fall over the rotating distributor. The slanting notch made over the rotary distributor distributes the seed equally in the desired number of rows (H) and seeds ultimately fall in the furrow opened by the furrow opener. The seed outlet in the furrow opener is designed in such a way that seed velocity is reduced considerably which avoids the seed bouncing to a great extent.

With the provisions of variator (D) provided on the star feeder, it is possible to vary the plot length. The machine can effectively be utilized for planting the breeders' experiment changing the seed varieties in inter-plots without stopping the machine intermittently at the end of a plot. Thus planting of about 200 plots per hour with the maximum of 22.5 m plot length can be attained easily depending upon the soil types. The effective spacing in rows can be varied between 10-15 cm and the number of rows 2-10 as a maximum.

#### Fertilizer Distributor Hege-33

The machine has a rotary distributor operated by a 12-volt battery at 1800 rpm. The rotor distributes the fertilizer in different tubes which falls on the ground in line as per the adjustment of the tube spacings. Preliminary distribution of fertilizer is done through another slow

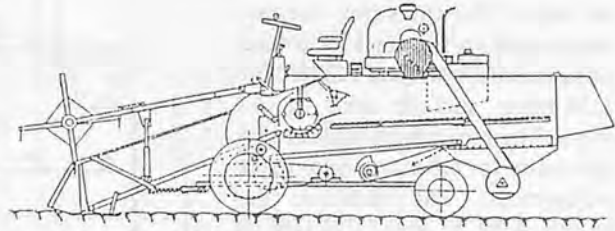
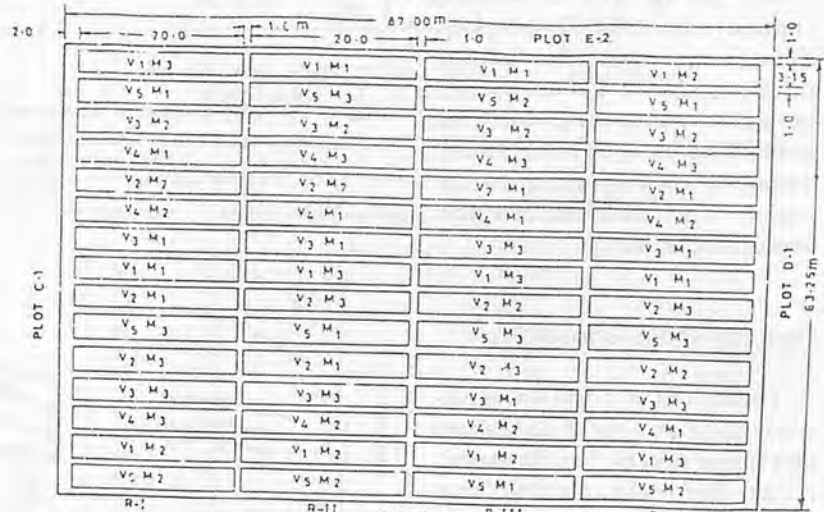

Fig. 4 Plot combine Hege 125-B.



M1-Seed and fertilizer mixed planting by Oyjord drill

M2- Fertilizer broad casted and seed drilled by Oyjord drill

M3-Seed and fertilizer both drilled separately by Oyjord drill

V1-JS-2 Soybean  
V2-SU-7244  
V3-Punjab-1  
V4-Ankur  
V5-Black

Fig. 5 Layout of the experiment.

speed rotor. Power to this rotor comes from the ground wheel through the plot length variator which controls the linear movement of the machine in conjunction with the quantity of fertilizer. A schematic view of the machine is shown in Fig. 3. The machine has special provisions for distributing the known quantity of fertilizer over a prefixed area uniformly. The number of rows can be adjusted as per needs. This machine can also apply fertilizers in a band form in between the rows of crops. The manually-pushed machine can be used for applying all types of granular fertilizers in the form of top dressing. The effective width can be adjusted up to 1.25 m at one setting.

The top dressing of urea (granular fertilizer) was done using the hand-pushed fertilizer distributor and the measured quantity of fertilizer was applied in each plot. Samples were collected over 30 x 21 cm size papers pre-spread in between the rows of crop.

#### Plot Combine Hege 125 B

The plot combine model Hege125-B was specially designed to meet the harvesting needs of breeding and agronomical experiments. The machine has 1.25 m cutter bar (1.50 m optional). It has provisions for collecting the harvest in gunny bags. For smaller sizes of plot samples, cassette-type plastic trays are provided. Samples

are collected at the end of each plot harvested and stored in plastic bags. The threshing concave has provisions for quick clearance, adjustments, swinging shaker with 1.55 mxm surface area in 2-3 steps. The reel has variable speed, provision for extension and height adjustment. The combine has length 4.30 m long, 1.4-1.65 m wide, 1.93 m height and weighs 1180-1350 kg with a working capacity of 60-120 plots/h. Though the engine has heating problem in hot Indian climate during harvesting, the problem has been solved using an indigenously assembled cooling system on the engine. The modified machine works satisfactorily.

## Results and Discussions

The Oyjord plot drill was extensively tried on four crop seasons and found suitable for the experiments. The results obtained thus for planting wheat and soybean in statistically planned experiments are shown in Figs. 6, 7 and 8. In general, the plant establishment was best in (M3) in comparison to (M1) and (M2) for most wheat and soybean varieties tried. However, few of the varieties of wheat and soybean had comparatively better plant stand when fertilizer dose was given by broadcast method (M2). In drilling the seed by Oyjord drill all the grains were distributed quite uniformly (Fig. 6). ( $\sigma = 0.3601$  and  $cv = 11.37\%$ ) The lower seed emergence obtained in (M1) and (M2) method was mainly due to reduced soil temperature in the vicinity of the seed when seed makes contact with the fertilizer, and in a few cases, molds formed over the seeds. Some varieties of seed V3 and V1 (wheat) and V3 (soybean) showed less response even when in near contact with the fertilizer and thus better seed emergence was ob-

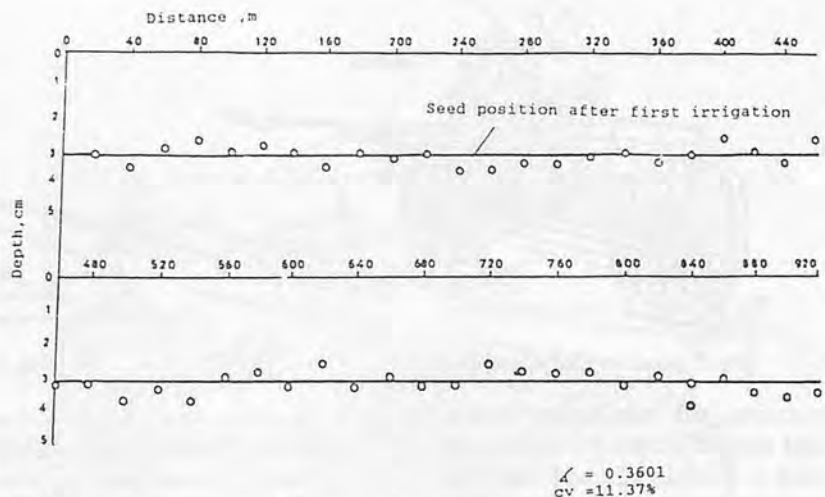

Fig. 6 Vertical placement of wheat seed by Oyjord drill.

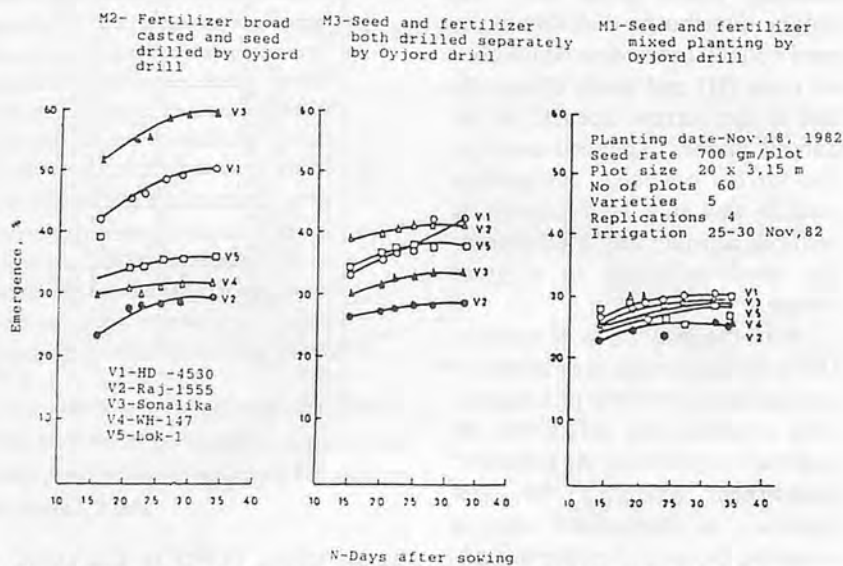

Fig. 7 Effect of planting method on seed emergence by Oyjord drill on wheat.

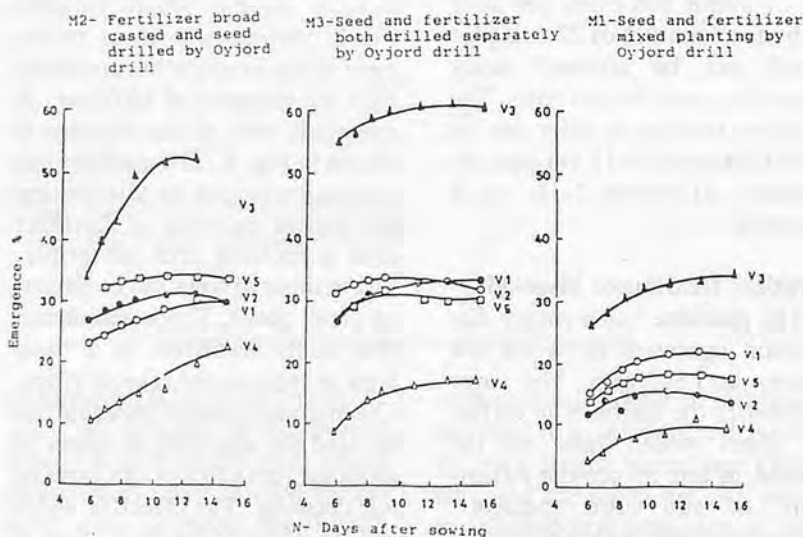

Fig. 8 Effect of planting method on seed emergence by Oyjord drill on soybean.



tained. The Oyjord plot drill is capable of planting almost all types of grains: broad and small. The performance is excellent with smaller seeds.

The Hege-33 fertilizer distributor is most suitable when top dressing of granular fertilizer is done and especially when certain fixed quantity of fertilizer is to be uniformly distributed in measured sizes of plots. The distribution pattern of fertilizer is plotted in Fig. 9. It is seen that the distribution of granular fertilizer varies within the range of 20 mg/cm<sup>2</sup> area. This variation is small and hence acceptable in the experiments. Since the machine is pulled in the field, it is quite tiring over the soft soil. Table 1 shows the yield of wheat and soybean in trials. Though there was a variation in wheat yield but it was not found significantly different as tillering has compensated for the low yield. In general, the yield in (M3) method was more than (M2) and (M1) for both wheat and soybean crops.

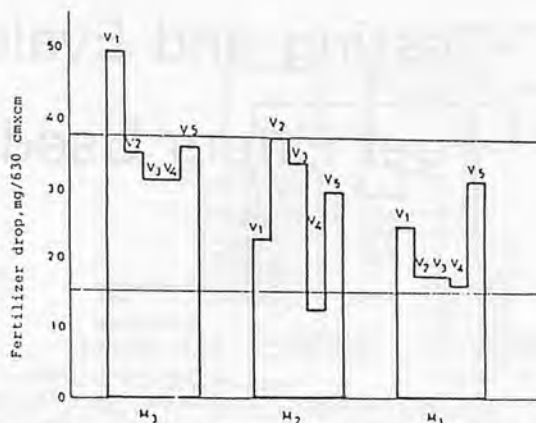

Fig. 9 Fertilizer distribution pattern by hand-pushed distributor.

Table 1 Effect of Fertilizer Application Methods During Seeding on Wheat and Soybean Yield

Treatments	No. of tillers/plant	Yield (q/ha, 8% db)	
		Wheat*	Soybean
1. M1 V1	12	43.65	2.50
2. M1 V2	7	45.25	3.48
3. M1 V3	9	44.44	5.56
4. M1 V4	6	50.79	0.61
5. M1 V5	6	49.60	9.25
6. M2 V1	7	39.28	3.40
7. M2 V2	9	39.20	5.77
8. M2 V3	8	46.42	10.09
9. M2 V4	10	44.84	1.04
10. M2 V5	10	47.22	5.17
11. M3 V1	7	45.63	3.89
12. M3 V2	7	49.99	5.07
13. M3 V3	10	42.85	6.36
14. M3 V4	9	49.60	2.21
15. M3 V5	6	48.80	8.96

\*Wheat yield difference was not found significant due to tillering.

## Conclusion

Based on the study the following conclusion is drawn;

Large numbers of experimental field trials of breeders and agronomists can be handled with desired accuracy and precision as the machine (Oyjord Plot Drill) can plant 40-50 plots/h in black soil without any varietal grain mixing. The application of fertilizer needs to be done in a separate operation prior to seeding the plots. Yield potential of crops could be increased. Field research time of scientists could be reduced considerably, enabling the bioscientists to handle larger plot samples and larger sizes of experiments in a particular season.

However, considering the initial costs of these machines and the

availability of spare parts in India, their development locally using indigenous materials is highly recommended. Individual institutions may also like to import their immediate needs.

## REFERENCES

- Oyjord, E. (1980) Proceedings of the fifth international conference on mechanization of field experiments, Wageningen, the Netherlands.
- Segler, G. (1977) Agricultural engineering in India and its importance for development, J. AMA, 6(2): 76-82.
- Yadav, B.G. (1983) Status of experimental field plot machinery in India, Proceedings of the summer institute on field plot machinery research design and application, CIAE, Bhopal.
- Yadav, B.G. (1983) Survey of availability and priority needs of experimental field plot machines in India, CIAE, Bhopal.
- Yadav, B.G. (1985) The proceedings of the national seminar cum workshop on experimental field plot machinery for mechanization of agricultural research in India. The second regional IAMFE conference, Technical proceeding No. CIAE/CPE/85/40. CIAE, Bhopal.
- Yadav, B.G.; Yadav, R.N.S. (1987) Short course on field plot machinery for mechanization of agricultural research. Tech. Report No. CIAE/CPE/87/67/CIAE, Bhopal. ■■

# Testing and Evaluation of Fuel Filters Used on Tractors

by  
A.K. Singh  
Technical Assistant  
Northern Region Farm Machinery  
Training and Testing Institute  
Hisar 125001, India

M.L. Mehta  
Senior Test Engineer  
Northern Region Farm Machinery  
Training and Testing Institute  
Hisar 125001, India

R. Tiwari  
Senior Test Engineer  
Northern Region Farm Machinery  
Training and Testing Institute  
Hisar 125001, India

## Abstract

Fuel filters are very important components in the fuel system of internal combustion engines. The tractors in India are generally equipped with diesel fuel supply system. Thus, a testing and evaluation of 4 brands of commercially available fuel filters was undertaken. The through flow rate of 1 m head varied from 47 l/h to 154 l/h and pressure drop varied from 811 mm to 927.2 mm. The filtering efficiency after lapse of 30 min of testing, varied from 37.5% to 77.78% compared with a minimum of 60% using primary filters and 15.79% to 97.22% compared with 95% using secondary filters. The tests indicated satisfactory performance of the Type-1 filter only.

## Introduction

With increasing farm mechanization the numbers and sizes of tractors have also been increasing in India. At present there are 14 major companies manufacturing tractors with a total installed capacity of about 0.1 million units annually in the range of 19 to 100 hp. Since the tractors in India predominantly use diesel fuel, fuel filters are very important component of the fuel supply system.

**Table 1** Characteristics of Fuel Filters

Type	Material	Dimension (mm)						
		A	B	C	D	E	F	G
I	Pri. cloth	143	82	24.5	59	14	8.7	7
	Sec. paper	143.3	81	21.8	31	14	11.0	8.5
II	Pri. cloth	142.8	81.5	23.8	17.3	14	8.1	7.5
	Sec. paper	146.2	80.7	21.5	33.2	13.3	11.8	8.7
III	Pri. cloth	132	80.4	26.9	36.9	19.6	4.4	0.8
	Sec. paper	132.6	71.8	26.2	38.2	19.8	5.4	1.2
IV	Pri. cloth	142	80.8	23.7	60.8	14.0	7.7	6.6
	Sec. paper	144.5	81.1	22.3	25.1	14.0	10.8	7.2

The proper functioning of filters is to clean the diesel fuel completely before it reaches the injection pump and the nozzle. This is most important with engine that run under very severe conditions of service and are exposed to atmosphere containing a high concentration of dust. Any dust particle coming with the fuel can damage the costly and precise parts, ultimately increasing the cost of operation. Moreover, faulty fuel filters can greatly affect the fuel consumption and available power. Thus the quality of fuel filters cannot be ignored in the use of tractors. Generally, two-stage fuel filters, i.e., primary and secondary are used in the fuel system.

The present study was undertaken with the objective of comparing filter performance in terms of specification, mechanical tightness, flow rate with pressure drop and filtering efficiency as per Indian Standard Nos. IS: 3169-1965 and IS: 3351-1968.

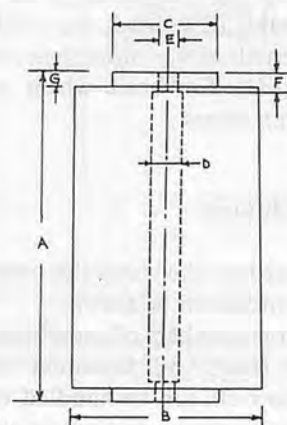

**Fig. 1** Dimension of filter element.

## Materials and Methods

Four different brands of 1.0 l capacity each fuel filters (primary and secondary) were procured from the market on random basis. The detailed characteristics of the filters are shown in **Table 1**.

## Experimental Set-up

### Mechanical Tightness

The purpose of this test was to

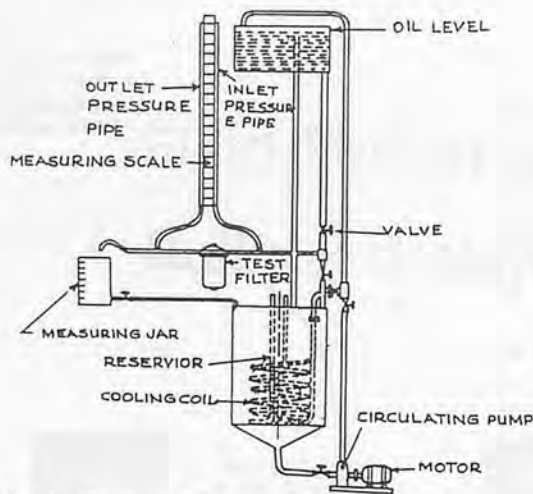

Fig. 2 Test set-up for flow rate and pressure drop.

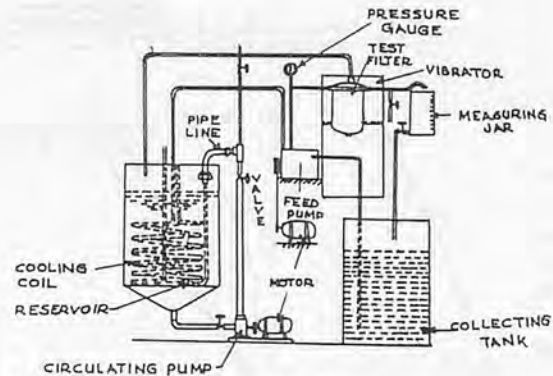

Fig. 3 Test set-up for filtering efficiency.

ascertain whether the filter assembly is leak-proof at normal working pressure. The cover and filter bowl were tightened by fixing screws with 2 to 2.5 kg-m torque. The filter assembly with its outlet blocked and its inlet connected to a pressurized air supply, was immersed completely in a bath of clean diesel oil. An air pressure of 2 kgf/cm<sup>2</sup> was applied on the inlet of the filter and maintained for 20 s.

### Flow Rate and Pressure Drop

The purpose of this test was to determine the flow rate of the filter and its corresponding pressure drop. A schematic arrangement of the test apparatus used is shown in Fig. 2. After cleaning the entire apparatus the reservoir was filled with 90 l of clean HSD oil. The filters (Pri/Sec) under test were fitted in place and manometer connections were made. The filter line was bled free of air and checked for any leakage. The specific gravity of the oil at the test temperature was determined. The data was recorded for different inlet and outlet pressures and time elapsed, in seconds, for 500 ml flow of oil at each head. Then calculations were made as follows:

$$\begin{aligned} \text{Flow rate (q)} &= 1800/t, \text{ l/h} \\ &= 0.850/(\text{Actual s.g. of HSD oil}) \times (H1 - H2) \text{ mm} \end{aligned}$$

where, H1 and H2 are pressure

readings of inlet and outlet respectively.

### Filtering Efficiency

The purpose of this test was to determine the cleaning efficiency of a filter, which is defined as the percentage of contaminant arrested in the filter when the HSD oil is contaminated with a Bosch type dust at the rate of 1 g/l. A schematic diagram of the test filter (one at a time) was mounted on a U plate which was vibrated at a frequency of 3 000 vibrations per min with an amplitude of 0.2 mm at the filter head using an electromagnetic device fixed to the top of the plate. A pressure gauge was also connected on the inlet side to register the inlet pressure. The reservoir was filled with 90 l HSD oil. Then 90 g of Bosch type dust was weighed and prepared into a thin slurry. The slurry was poured into the tank the contents of which were agitated by rapid circulation of oil. After allowing sufficient time for mixing, the vibrator and fuel feed pump were restarted in order to allow the contaminated oil to flow through the system. The flow time for 500 ml was recorded and sample of HSD oil from outlet was also collected. The readings were taken after every 5 min. When 30 min had elapsed from the start of test, the last sample was drawn and the flow rate was again measured. The dust concentration in the sample was

determined by using the centrifuge method. A high speed centrifuge with an acceleration of more than 600 g was used where a 10 ml representative sample in each tube was transferred and put in the centrifuge action for 10 min. The centrifuge was then stopped gradually and the sediment collected at the bottom of tube were recorded. Filtering efficiency was then calculated as:

$$n = \frac{X^1 - X^2}{X} \times 100$$

Where,

- n = Filtering efficiency %
- X<sup>1</sup> = Dust concentration in the tank
- X<sup>2</sup> = Dust concentration at the outlet

### Results and Discussion

The relationship between pressure drop and flow rate on ordinary graph paper indicates that through flow at 1 m pressure varied from 47 l/h to 154 l/h having flow rate (Fig. 4). Pressure drop varied from -5.7 to +7.8% from standard values given in BIS code.

The filtering efficiency of primary and secondary filters of different brands indicates that after 5 min of start of test the efficiency ranged from 21.3% to 72.2% in primary filters, and from 11.1% to 95.5% for secondary

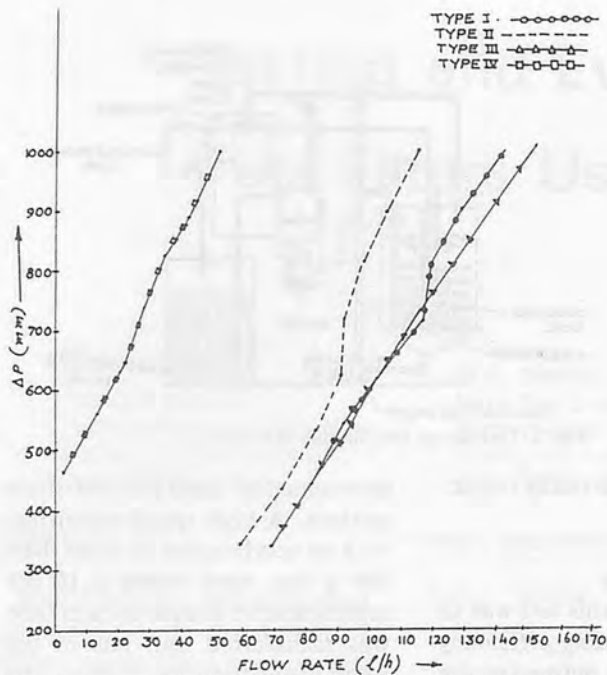

Fig. 4 Pressure drop vs flow rate test rated flow at 1 m head.

filters. After 30 min of test, the efficiency varied from 37.5% to 77.8% for primary filters and from 15.8% to 97.2% for secondary filters.

### Conclusion

There is a wide variation in specifications of different brands fuel filters.

All filters were mechanically tight-fitting when tested as no leakage was observed.

Through flow rate at 1 m head was lowest in Type-IV filter.

The pressure drop was highest (927.2 mm) for the Type-IV filter.

The filtering efficiency of primary filter, after a lapse of 5 min testing was much below in Types I, II and III filters. After a lapse of 30 min the efficiency was much lower than Types-II and III filters than the prescribed limits of referred BIS codes.

The filtering efficiency of secondary filters, after a lapse of 5 min in test was only 11.11% in Type-II filter as against the requirement of 65%. After a lapse

of 30 min the efficiency was only 15.79% for the Type-IV filter as against the requirement of 95%.

Of the four brands of filters tested, only the Type-I provided a satisfactory performance.

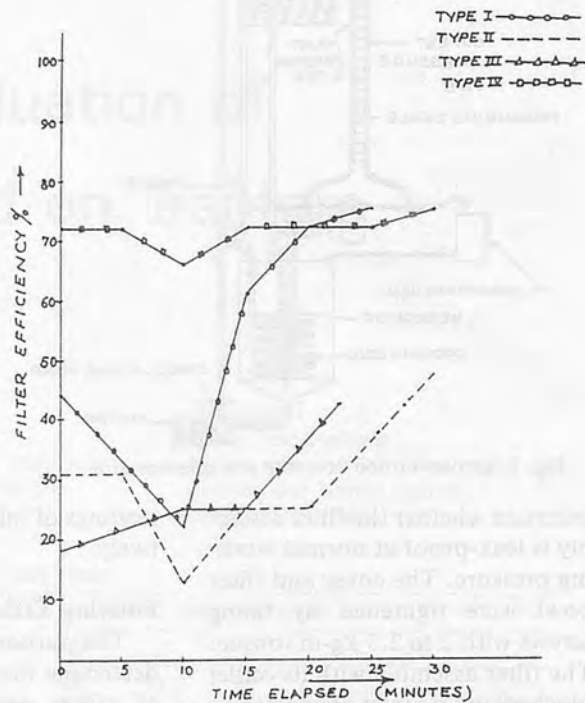

Fig. 5 Filtering efficiency of pre-filter.

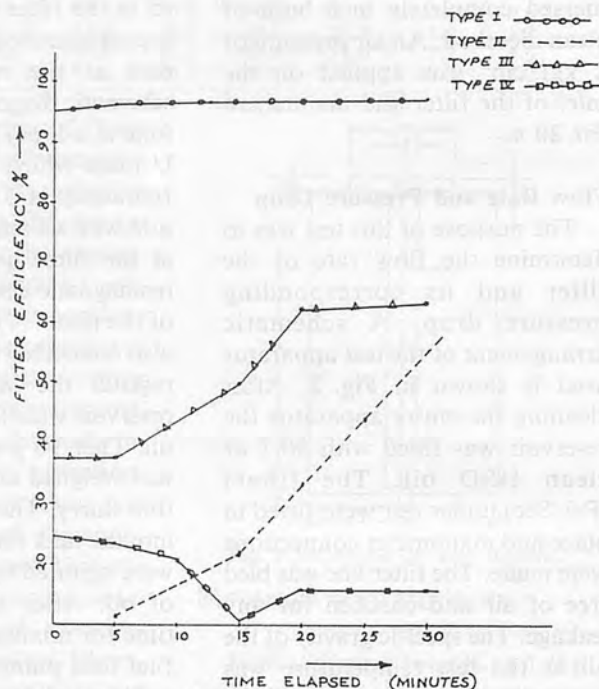

Fig. 6 Filtering efficiency of fine filter.

### REFERENCES

1. Indian Standard, 1965. Specification for two Stage, one litre fuel filters for Diesel Engines IS: 3169.
2. Indian Standard, 1968. Methods of Test for Diesel Engine fuel filters, IS: 3351. ■■

# Field Performance Evaluation of Bullock-drawn Puddler



by  
**D.N. Sharma**  
Coordinator  
Krishi Gyan Kendra  
Hisar, India



**M.L. Jain**  
Prof. of Agric. Engg. and  
Director of Publications  
Haryana Agric. Univ.  
Hisar, India

**S.C.L. Premi**  
Agric Engineer  
Dept. of Agric. Engg.  
Haryana Agric. Univ.  
Hisar, India

## Abstract

Three years' trials were conducted to evaluate the performance of different bullock-drawn puddling equipment, i.e., rotary blade puddler, disc harrow and harrow-cum-puddler in comparison with the desi plough (indigenous). The performance of rotary blade puddler was found very satisfactory when operated twice in the field before transplanting the crop. It was very effective in reducing the percolation loss as it provided good 'puddle' with puddling index of 49.10-57.02% in clay loam soil. The average depth of puddling was 110-150 mm under different conditions. Its average draft was 48.7, 51.95 and 59.8 kg at three different locations as compared to 119.02, 115.40 and 87.0 kg in bullock-drawn disc harrow and 34.0 kg with desi plough. It required about 18 hours to do the puddling in 1 ha whereas bullock-drawn disc harrow required 23.5 h to do the puddling in 3 operations and desi plough required 55.6 h for similar results. Significantly higher yields were obtained in T<sub>2</sub> (6 896, 4 850 and 4 940 kg/ha) followed by T<sub>3</sub> (6 771, 4 730 and 4 200 kg/ha at Kaul, Hansi and Dabra, respectively). The energy required and cost of operation of bullock-drawn disc harrow and desi plough was 1.35 and 4.64 times the re-

quirements of bullock-drawn rotary blade puddler.

## Introduction

Paddy is usually grown by transplanting seedlings under flooded conditions. This needs a well-prepared soft soil bed which is obtained by puddling. Puddling, i.e., churning or tilling the soil at high moisture content is a very vital secondary tillage operation. Adequate puddling of soil is important from the point of view of reducing loss of water and nutrients by percolation. According to Yadav (1972), approximately 75% of the total water supplied to the paddy crop is lost through deep percolation during submergence. Furthermore, the weeds are destroyed and favourable conditions for plant growth are created.

Percolation of water and nutrients can be reduced by improving the quality of puddling. Several authors have indicated different methods for measuring puddling quality like puddling index, mean weight diameter, cone index, hydraulic conductivity and soil dispersion. Pandya (1962) and Sharma and Singh (1983) used simple cone penetrometer, Bhola and Arya (1964), Awadhwal and Singh (1981) used hydraulic conductivity,

Agarwal et al. (1978) used soil dispersion method and Tiwari and Singh (1984), Badhe et al. (1984), and Sharma and Singh (1983) used puddling index as a measure of puddling quality to compare the performance of various types of puddling equipment available in the country.

The present study was conducted to compare the performance of bullock-drawn rotary blade type puddler, disc-harrow and harrow-cum-puddler in comparison with the desi plough which is the local practice being followed by farmers. The number of operations to be performed were also standardized on the basis of this study.

## Methods and Materials

A bullock-drawn rotary blade type puddler was fabricated according to I.S.I. standard (Fig. 1) and a bullock-drawn harrow-cum-puddler (Fig. 2) developed by Garg and Sharma (1984) was procured from Punjab Agricultural University, Ludhiana. Experiments were conducted at Rice Research Station, Kaul in clay loam soil (clay 48.6%, silt 22.9% and sand 28.5%) during 1983-84, at the Government Agriculture Farm, Hansi (1984-85) under similar soil conditions and at Dabra village (1985-86) to com-

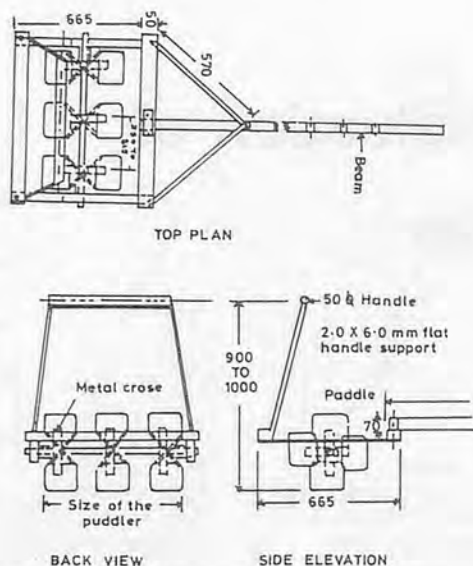

Fig. 1 Rotary blade bullock-drawn puddler.

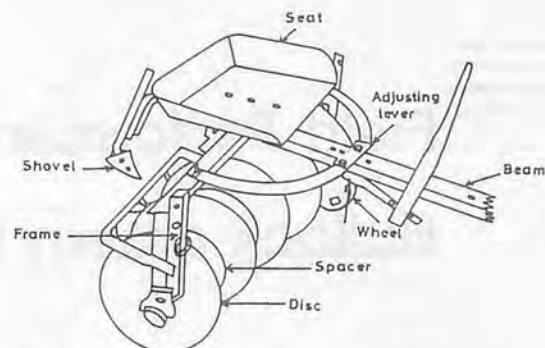

Fig. 2 Bullock-drawn harrow-cum-puddler.

Table 1 Specifications of Puddling Equipment

Particulars	Rotary blade puddler	Disc harrow	Harrow-cum-puddler	Desi plough
Power required	1 pair of bullocks	1 pair of bullocks	1 pair of bullocks	1 pair of bullocks
No. of gangs	1	2	2	—
No. of blades/discs in each gang	3 sets of 4 blades	3 discs on each gang	3 discs on each gang	1 share
Size of blade/disc (mm)	200 x 150 x 3	410 dia	450 dia	Triangular share with cutting width of 150 mm
Distance between two sets of blades/discs (mm)	250-275	215	140	—
Blade/disc angle (degree)	45°	0-30° adjustable	0-25° adjustable	—
Working width of machine (mm)	780-325	1075	840	150
Draft (kg)	45-60	100-200	75-105	45-65
Field capacity (ha/h)	0.112	0.145	0.140	0.035
Approximate cost (Rs)	550	750	1000	200

pare the performance of bullock-drawn rotary blade puddler, disc-harrow and harrow-cum-puddler with traditional desi plough. The detailed specifications of the puddling equipments are given in Table 1. The study was conducted with the following treatments:

- T<sub>1</sub> = Rotary blade puddler once
- T<sub>2</sub> = Rotary blade puddler twice
- T<sub>3</sub> = Disc harrow thrice
- T<sub>4</sub> = Disc harrow twice
- T<sub>5</sub> = Harrow-cum-puddler twice
- T<sub>6</sub> = Desi plough twice

A plot size of 60 x 15 m was chosen for each treatment for easy operation of puddling implements. Later on, the net plot size of 15m<sup>2</sup> with 3 replications for recording yield data was earmarked. HKR-101, IR-8 and PR-106 varieties of paddy were transplanted at Kaul,

Hansi and Dabra, respectively. To raise the fertility status of the soil, a dose of 120 kg N + 60 kg P<sub>2</sub>O<sub>5</sub> + 25 kg ZnSO<sub>4</sub> per ha was applied. The fields were harrowed twice under dry condition and then irrigated. Different puddling equipments were operated. The number of operations were according to the treatments in standing water to a depth of 100 mm. A planker was used to level the field. For each replication, observations like sample of soil water suspension, time spent in actual operation, depth of puddling, draft requirement and infiltration rate were recorded to determine puddling index and dispersion ratio.

For determining the puddling index (P.I.), the samples of soil water suspension were taken by

immersing a glass tube to a depth of about 100 mm. The samples from a number of points were collected in measuring cylinders. These were kept undisturbed up to 48 h to allow the soil to settle. The volume of soil settled was noted and the P.I. was calculated by the following formula reported by Badho et al. (1984):

$$P.I. = \frac{V_S}{V_T} \times 100$$

Where,

V<sub>S</sub> = Volume of settled soil

V<sub>T</sub> = Total volume of sample

The percolation loss was determined by using infiltrometers of 300 mm diameter and 450 mm long cylinders open at both ends and driven up to a depth of 130 mm in each plot after puddling. The water level in the infiltrometers was noted and percolation loss was calculated. The draft requirements of the puddling implements were measured by a spring type dynamometer/balance. Yield data were recorded from 6 locations selected randomly in each treatment.

## Results and Discussion

The performance results of different bullock-drawn puddling implements in comparison with traditional desi plough under different soils are given in Tables 2 to 5.

### Soil Properties

Table 2 gives the percolation losses and basic infiltration rates in different treatments. The highest percolation loss was observed

in T<sub>1</sub> where a minimum of operations were carried out. It was lowest in T<sub>3</sub> and T<sub>2</sub> followed by T<sub>6</sub>, T<sub>4</sub> and T<sub>5</sub>, respectively. This was due to the larger number of operations given in T<sub>3</sub>. Moreover, due to repeated operations of the disc harrow, a hard pan might have been formed which would ultimately reduce the percolation losses. In treatments T<sub>2</sub> and T<sub>3</sub>, for 16 to 60 min, the percolation losses were almost equal. But afterwards it was lowest in T<sub>3</sub>. Similar results were achieved with puddler also by increasing the number of operations. Rane and Varade (1972) also tested various bullock-drawn implements for puddling and observed that the angular blade puddler was effective in reducing percolation losses. For basic infiltration rates, T<sub>3</sub>, T<sub>2</sub> and T<sub>6</sub> were equal followed by T<sub>4</sub>, T<sub>5</sub> and T<sub>1</sub>, respectively. Although, the infiltration rate was lowest in T<sub>3</sub> but considering other factors, i.e., puddling index, infiltration, puddling depth, field capacity and energy requirement in all the treatments, T<sub>2</sub> was better than T<sub>1</sub>, T<sub>3</sub>, T<sub>4</sub>, T<sub>5</sub> and T<sub>6</sub>. Shama and Singh (1983) found that a rotary blade puddler with 30-50° blade angle with two passes, performed better than other implements for puddling operation.

It is clear from Table 3, that highest dispersion ratio (1.629) was observed in T<sub>3</sub> followed by T<sub>2</sub>, T<sub>4</sub>, T<sub>6</sub> and T<sub>1</sub>, respectively. It is also evident from Table 5 that maximum value of puddling index was observed in T<sub>2</sub> (49.1 and 57.02%) and T<sub>4</sub> (47.70%). Higher value of puddling index in T<sub>2</sub> was attributed to better churning of soil by the puddler with blade angle of 45°. A screw shape is formed which has direct impact on churning quality of soil and water mixture. According to Tiwari and Singh (1984), the puddling index increased almost at uniform rate as the puddling operation increased from 2 to 3. On the other hand, in T<sub>3</sub> the value of

**Table 2** Effect of Different Puddling Treatments on Percolation Loss (Unit: mm)

Time (min)	Kaul (1983-84)			Hansi (1984-85)				Time (min)	Hansi (1985-86)					
	Percolation loss			Percolation loss					Percolation loss					
	T <sub>1</sub>	T <sub>2</sub>	T <sub>3</sub>	T <sub>1</sub>	T <sub>2</sub>	T <sub>3</sub>	T <sub>4</sub>		T <sub>1</sub>	T <sub>2</sub>	T <sub>3</sub>	T <sub>4</sub>	T <sub>5</sub>	T <sub>6</sub>
5	4.0	2.3	2.3	5.0	3.0	3.0	4.0	60	2.0	1.5	1.5	2.0	2.0	2.0
30	7.3	3.8	3.8	8.5	5.5	5.4	7.5	120	3.5	3.0	3.0	4.0	4.0	4.0
60	8.5	5.0	4.5	9.8	6.4	6.3	6.3	240	6.5	5.0	5.0	7.0	7.0	7.0
90	9.5	6.0	5.0	10.9	7.0	7.0	9.7	360	9.5	6.5	6.5	9.5	9.5	9.0
120	10.3	6.5	5.3	11.7	7.5	7.5	10.4	480	12.0	8.0	8.0	12.0	12.0	11.0
150	11.0	7.0	5.5	12.5	8.0	7.95	11.1							
Basic I.R. (mm/h)*	1.4	1.0	0.5	1.6	1.0	0.9	1.4	Basic I.R. (mm/h)	1.25	0.75	0.75	1.25	1.25	1.0

\*I.R.: Infiltration rates

**Table 3** Effect of Puddling Treatments on Soil Particle Dispersion

Treatment	Hansi (1985-86)						Dabra (1985-86)			
	Water dispersible silt and clay		Complete dispersed silt and clay		Dispersion ratio		Water dispersible silt and clay	Complete dispersed silt and clay	Dispersion ratio	
	0-50cm depth	5-10cm depth	0-50cm	5-10cm	0-5cm	5-10cm				Average
T <sub>1</sub>	32.82	40.78	53.0	57.6	0.6192	0.707	0.66	35.8	38.2	0.938
T <sub>2</sub>	59.31	47.76	53.0	57.6	1.111	0.829	0.28	56.7	38.2	1.484
T <sub>3</sub>	46.78	50.48	53.0	57.6	0.882	0.876	0.88	62.26	38.2	1.629
T <sub>4</sub>	46.65	36.57	53.0	57.6	0.88	0.634	0.76	54.56	38.2	1.428
T <sub>5</sub>	32.77	37.65	53.0	57.6	0.618	0.653	0.64	45.0	38.2	1.178
T <sub>6</sub>	51.62	26.20	53.0	57.6	0.973	0.454	0.71	50.72	38.2	1.327

**Table 4** Effect of Different Puddling Treatments on Yields of Paddy (Unit: kg/ha)

Replications	Kaul (1983-84)			Hansi (1984-85)				Dabra (1985-86)					
	Yield			Yield				Yield					
	T <sub>1</sub>	T <sub>2</sub>	T <sub>3</sub>	T <sub>1</sub>	T <sub>2</sub>	T <sub>3</sub>	T <sub>4</sub>	T <sub>1</sub>	T <sub>2</sub>	T <sub>3</sub>	T <sub>4</sub>	T <sub>5</sub>	T <sub>6</sub>
1	6560	6620	6750	4250	5000	7450	4500	4380	4980	4100	3750	3250	2680
2	6750	6880	6750	4100	4800	4800	4350	4700	4900	4300	4130	3180	3450
3	5880	7180	6810	4550	4750	4650	4660	—	—	—	—	—	—
Average	6400	6890	6770	4300	4850	4730	4500	4540	4940	4200	3940	3210	3060

puddling index was almost equal to T<sub>2</sub>, due to greater number of operations as discs of harrow simply cut and throw the soil without churning.

Table 5 shows that maximum depth of puddling was obtained in T<sub>2</sub> (150 and 145.3 mm at Kaul and Hansi, respectively) followed by T<sub>3</sub> (144.2 and 130.5 mm); T<sub>1</sub> (119.0 and 125.4 mm) and T<sub>4</sub> (106.0 mm). But at Dabra, it was maximum in T<sub>5</sub> (136 mm) followed by T<sub>3</sub> (126 mm), T<sub>4</sub> (111 mm); T<sub>2</sub> (110 mm); T<sub>6</sub> (108 mm) & T<sub>1</sub> (100 mm). Lowest draft was observed with desi plough (T<sub>6</sub>) followed by rotary blade puddler, harrow-cum-puddler and bullock-drawn disc harrow. The draft for puddler varied between 32.88 to 48.5 kg (avg. 40.6 kg), 39.92 to 57.92 (avg. 48.92 kg) and 44.0 to 79 kg (avg. 61.5 kg) in first pass of

puddler at Kaul, Hansi and Dabra, respectively, as compared to 39.0 to 58.4 kg (average 48.7); 44.20-59.70 kg (average 51.90 kg) and 40.7-79.0 (average 59.8 kg), respectively, during second pass of the puddler (T<sub>2</sub>). This is due to proper churning of soil after second pass and higher depth of penetration of puddler. The draft in disc harrow was quite high, i.e., 104 to 1133.9 kg (average 87.0 kg) in T<sub>3</sub> at Kaul, Hansi and Dabra, respectively. This was due to loss/no control over depth, greater number of discs in harrow and sticking of soil to the discs. In harrow-cum-puddler, the draft varied between 61-113 kg (avg. 88 kg). The field capacities of 0.112 to 0.113, 0.056-0.057, 0.042-0.043, 0.06, 0.75 and 0.018 ha/h were observed in T<sub>1</sub>, T<sub>2</sub>, T<sub>3</sub>, T<sub>4</sub>, T<sub>5</sub> and T<sub>6</sub>, respectively. The least area was

**Table 5 Performance Results of Different Bullock-drawn Puddling Equipment**

Particulars	Kaul (1983-84)			Hansi (1984-85)				Dabra (1985-86)					
	T <sub>1</sub>	T <sub>2</sub>	T <sub>3</sub>	T <sub>1</sub>	T <sub>2</sub>	T <sub>3</sub>	T <sub>4</sub>	T <sub>1</sub>	T <sub>2</sub>	T <sub>3</sub>	T <sub>4</sub>	T <sub>5</sub>	T <sub>6</sub>
Average puddling depth (mm)	119.0	150.0	144.2	125.4	145.3	130.5	106.0	100	110	126	111	136	108
Draft (kg)													
a) Minimum	32.88	39.0	104.10	39.93	44.20	101.20	101.2	44.0	40.7	61.0	58.0	61.0	17.0
b) Maximum	48.5	58.4	133.94	57.92	59.70	129.6	129.6	79.0	79.0	113.0	113.0	115.0	51.0
c) Average	40.6	48.7	119.02	48.92	51.95	115.4	115.4	61.5	59.8	87.0	85.5	88.0	34.0
Puddling index (%)	34.80	49.10	48.20	32.35	57.02	56.70	47.70	—	—	—	—	—	—
Silt clay dispersed (%)	—	—	—	—	—	—	—	35.8	56.7	62.3	54.6	45.0	50.0
Average percolation (mm/h)	1.5	1.0	0.5	1.6	1.0	0.9	1.4	1.02**	0.64**	0.68**	0.82**	0.72**	0.60**
Field capacity (ha/h)	0.113	0.056	0.043	0.112	0.056	0.042	0.06	0.113	0.057	0.04	0.06	0.075	0.018
Time for puddling one ha (h)	8.85	17.7	23.45	9.09	18.18	23.81	16.67	8.9	17.6	25.0	16.7	13.3	55.6
Yield (kg/ha)	6396	6896	6771	4300	4850	4730	4500	4540	4940	4200	3940	3210	3060
Total energy (kWh/ha)	7.30	14.53	19.24	7.46	14.92	19.53	13.68	7.30	14.44	20.52	13.70	10.92	41.61
Energy (kWh/g of grain)	0.114	0.211	0.284	0.173	0.307	0.413	0.304	0.16	0.292	0.489	0.348	0.34	1.355
Cost of operation (Rs/ha)	55.32	110.63	146.56	73.71	147.71	193.45	137.44	71.75	141.9	201.56	135.44	107.23	448.27

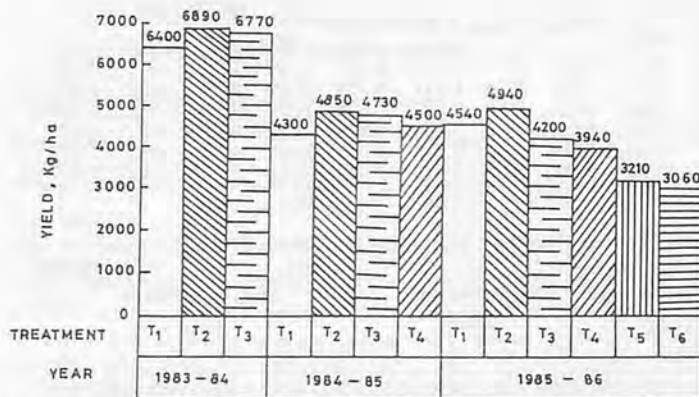

Fig. 3 Influence of puddling treatments on the yield of paddy.

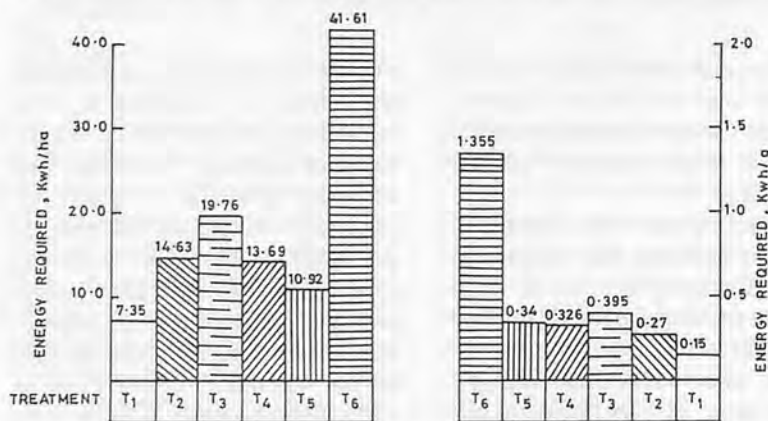

Fig. 4 Energy requirements influenced by puddling treatments.

prepared by desi plough (T<sub>6</sub>) due to increased number of operations and minimum width. About 55.6 h were required with desi plough to do the puddling of 1 ha as compared to 17.82 h with T<sub>2</sub> (puddler twice) and 13.30 h with harrow-cum-puddler (T<sub>5</sub>). Garg and Sharma (1984) compared the performance of harrow-cum-puddler with disc

harrow and soil stirring plough and found that soil stirring plough required about 54 h/ha to do the puddling operation as compared to 10 h with harrow-cum-puddler. A study conducted by Guruswami et al. (1980) also reveals that the time required by the country plough was significantly higher than that of other implements. The above

findings are in agreement with the findings of Garg and Sharma (1984) and Guruswami et al. (1980).

### Yield and Economics

Table 4 shows the effect of puddling on the yield of paddy crop under different treatments. The highest yield was observed in T<sub>2</sub> (6 890 and 4 850 kg/ha at Kaul and Hansi, respectively) followed by T<sub>3</sub> (6 770 and 4 730 kg/ha), T<sub>4</sub> (4 500 kg/ha) and T<sub>1</sub> (6 400 and 4 300 kg/ha). But during the year 1985-86, the highest yield was observed in T<sub>2</sub> (4 940 kg/ha) followed by T<sub>1</sub> (4 540 kg/ha), T<sub>3</sub> (4 200 kg/ha), T<sub>4</sub> (3 940 kg/ha), T<sub>5</sub> (3 210 kg/ha) and T<sub>6</sub> (3 060 kg/ha), respectively. This was due to better puddling and providing favourable conditions for establishment of good crop and finally increased yields. Dutt (1948), Sanchez (1973) and Tiwari and Singh (1984) also reported that the puddling created favourable conditions for the growth of rice plant mainly through reduced leaching/loss of water and nutrients. However, during the year 1985-86 at Dabra, very low crop yields, in general, were recorded due to scarcity of irrigation water and light soils. Table 5 shows the energy requirement and cost of production of paddy under different treatments and cost of production of paddy under different treatments. The total energy requirements for T<sub>1</sub>, T<sub>2</sub>, T<sub>3</sub>, T<sub>4</sub>, T<sub>5</sub> and T<sub>6</sub> worked out to be 7.35, 14.63, 19.76, 13.69,



10.92 and 41.61 kWh/ha, respectively. Desi plough required about 2.84 times the energy in rotary blade. The cost of production was lower in T<sub>2</sub> (Rs 110.63, Rs. 147.71 and Rs. 141.9/ha) as compared to T<sub>3</sub> (Rs. 146.56, Rs. 193.45 and Rs. 201.56). T<sub>1</sub> required only Rs. 55.32 to Rs. 71.75/ha for puddling operation. But, the puddling depth, puddling index and crop yields were quite low. The requirement of energy and cost of cultivation in T<sub>3</sub> was about 1.35 times higher than in T<sub>2</sub>. The maximum cost of production was recorded in T<sub>6</sub> (Rs. 448.27/ha) followed by T<sub>3</sub> (146.56, 193.45 and 201.56), T<sub>2</sub> (Rs. 110.63, 193.45 and Rs. 201.56/ha), & T<sub>4</sub> (Rs. 135.49/ha), T<sub>5</sub> (Rs. 107.23/ha) and T<sub>1</sub> (Rs. 55.32 to Rs. 71.75/ha).

The findings in the foregoing experiments were tested and demonstrated at the farmers' field and the results are reported in Table 6 and 7.

It is clear from Table 6 that there was no significant difference between the average yields when puddling was done with the help of puddler or desi plough. But slightly lower yield (47.5 q/ha) was recorded with the use of disc harrow. The above findings are ably supported by the percolation losses and basic infiltration rates reported in Table 7. Minimum percolation loss (6.5 mm in 1 060 min) with basic infiltration rate of 0.37 mm/h was recorded in the plot puddled by desi plough followed by paddy puddler (8.8 mm in 1 060 min with basic IR 0.49 mm/h) and disc harrow (11.5 mm in 1 060 min with basic IR of 0.64 mm/h). Better results were obtained with the use of desi plough and puddler because these implements gave better churning effects to the soil and water mixture giving favourable conditions for plant growth and reduced percolation losses.

Table 6 Effect of Puddling on Yield of Paddy Crop at Farmed Fields (Ram Rai)

Repliations	Yield (E/ha)								
	Puddler			Desi plough			Disc harrow		
	S <sub>1</sub>	S <sub>2</sub>	Mean	S <sub>1</sub>	S <sub>2</sub>	Mean	S <sub>1</sub>	S <sub>2</sub>	Mean
R <sub>1</sub>	40	55	47.5	50	55	52.5	37.5	57.5	52.5
R <sub>2</sub>	47.5	50	48.75	37.5	52.5	45.0	40.0	50.0	45.0
R <sub>3</sub>	40	62.5	51.25	37.5	65	51.25	37.5	52.5	45.0
Mean	42.5	55.83	49.16	41.67	59.61	49.60	38.3	53.3	47.5

S<sub>1</sub>, S<sub>2</sub> — Location of sites.

Table 7 Effect of Puddling on Percolation Loss at Farmers' Fields (Ram Rai)

Time (min)	Percolation loss (mm)								
	Paddy puddler			Desi plough			Disc harrow		
	S <sub>1</sub>	S <sub>2</sub>	Avg.	S <sub>1</sub>	S <sub>2</sub>	Avg.	S <sub>1</sub>	S <sub>2</sub>	Avg.
60	4.0	1.0	2.5	1.0	1.0	1.0	4.0	2.0	3.0
120	5.0	2.0	3.5	2.0	1.0	1.5	6.0	4.0	5.0
180	6.0	3.0	4.5	3.0	2.0	2.5	6.0	6.0	6.0
240	6.5	4.0	5.3	3.0	2.5	2.75	7.0	8.0	7.5
1060	9.0	8.5	8.8	5.0	8.0	6.5	11.0	12.0	11.5
Basic IF (mm/h)	0.5	0.47	0.49	0.28	0.45	0.37	0.61	0.67	0.64

S<sub>1</sub>, S<sub>2</sub> — Location of sites

#### REFERENCES

- Agarwal, M.C., R. Singh, M.L. Batra and R.P. Aggarwal. 1978. Evaluation of different implements for puddling of rice soils. IL RISQ Anne XXVII, No. 4.
- Awadhwal, N.K. and Singh, C.P. 1981. Puddling of rice soil-1: Effect of puddling on hydraulic conductivity and pore space. Paper presented at XVIII Annual convention of ISAE at Karnal. Paper No. 81-F PM-109.
- Badhe, V.T., Gupta, C.P. and Bhole, N.G. 1984. Performance index for puddler. Paper presented at XXI ISAE convention held at New Delhi.
- Badhe, V.T. and Patil, S.P. 1984. Design and development of a serrated blade rotary puddler. Paper presented at XXI Annual convention of SIAE held at New Delhi.
- Bhole, N.G. and Arya, A.C. 1964. Measurement of quality of puddler. Journal of ISAE Vol. 1 (1): 27-30.
- Dutt, A.K. 1948. Puddling and other treatments in relation to soil structure and crop growth. Journal of American Soc. of Agronomy Vol. 40 (4): 324-328.
- Garg, I.K. and Sharma, V.K. 1984. Design, development and evaluation of bullock drawn harrow-cum-puddler. Paper presented in XXI Annual convention of SIAE held at IRRI, New Delhi. Paper No. 84-1104.
- Pandya, A.C. 1962. Puddling of soil for paddy cultivation. The Agricultural Engineer. 8: 16-18.
- Rane, D.P. and Varale, S.B. 1972. Hydraulic conductivity as an index as evaluating the performance of different puddlers. J. Agric. Engg. 9 (1): 11-14.
- Guruswami, T, Naraini, N.S. and Sundarappa, B.S. 1990. Bullock drawn puddlers are on par with power tiller operated rotavator. Current Research 9: 75-77.
- Sanchez, P.A. 1973. Puddling tropical, rice soils 2. Effect of water losses. Soil Sci. 115: 303-308.
- Sharma, I.S.R.P. and Singh Bachehan 1983. Performance analysis of bullock-drawn rotary puddlers. Paper presented at XX Annual Convention of ISAE at Pantnagar Paper No. 83-1104.
- Taneja, M.L. and Patnaik, S. 1962. Technique of determining the degree and depth of soil puddle. Rice News Letter: 10 (1): 27-28.
- Tiwari, G and Singh, Bachchan 1984. Effect of blade angle and width of tractor-operated puddler on puddling quality. Paper presented at XXI Annual Convention of ISAE at New Delhi. Paper No. 84-1103.
- Yadav, J.S.P. 1972. Water Management and irrigation scheduling in relation to rice production. Oryza 9 (2): 77-96. ■■

---

# Power Requirements of Tillage Implements

---



by  
**Jan Muhammad Baloch**  
Asst. Prof.  
Farm Power and Machinery  
Sind Agriculture Univ.  
Tandojam, Pakistan

**Shah Nawaz Mirani**  
Asst. Prof.  
Basic Engineering  
Sind Agric. Univ.  
Tandojam, Pakistan



**Ali Nawaz Mirani**  
Lecturer  
Farm Power and Machinery  
Sind Agriculture Univ.  
Tandojam, Pakistan



**Sheruddin Bukhari**  
Assoc. Prof.  
Farm Power and Machinery  
Sind Agriculture Univ.  
Tandojam, Pakistan

## Abstract

Power requirements of tillage implements play an important role in the design of tillage implements, therefore, a study on selected implements such as rear-mounted three-bottom moldboard plow, rear-mounted three-diskplow and rear-mounted tandem disk harrow was carried out on Latif Farm of Sind Agriculture University, Tandojam. The soils of the farm were of clay loam type having moisture content of about 16% at depth of 15 cm. Various parameters pertaining to the implement performance were studied. Power requirements of the implements under study were calculated and it was concluded that the disk plow in third gear speed showed maximum power requirements as compared with other implements. Therefore, it is suggested that disk plow may be used on clay loams.

## Introduction

The use of agricultural implements in Pakistan is becoming popular. The design and development of these implements are primarily based on hit-and-trial methods. None of the implement manufacturing factories have qualified personnel in the field of design and development of tillage machines. There is not a single tillage implement (indoor or outdoor) testing laboratory wherein the durability and performance tests could be carried out. The result is that unreliable machines are appearing in the market giving a great set-back to the farm mechanization program of the country. This is one reason why mechanization of many crops has not yet been adopted.

The best criterion for the suitable tillage implement is the power requirement which determines the size of the tractor. Therefore, it is imperative that the implement manufacturer must be aware with the importance of the power requirements of various tillage implements so that implements could be designed and manufac-

ured in accordance with the size of the tractors available in the country.

The proper knowledge of design principles saves time, material and cost of production. Design principle involve the application of forces acting on the implements, their magnitude and direction as well. Power is a function of force acting on the implement and the velocity with which the implement is moving in the soil.

A tillage implement moving at a constant speed is subject to the forces such as weight of the implement, soil forces acting upon the implement and the forces acting between the implement and the tractor. The resultant of all these three forces is the pull of the tractor upon the implement.

Depth of cut, width of cut, tool shape, tool arrangement and travel speed are factors that affect draft and energy utilization. The effects of these parameters vary with different types of implements and with different soil conditions.

For this study three-bottom

mounted moldboard plow, three-disk mounted diskplow and mounted tandem disk harrow were used. The aim of this study was to evaluate the power requirements of different tillage implements. This type of study can provide a design basis to the implement designer and selection basis to the farmer.

### Method of Study

In tillage tool design, a limited number of abstract factors become of primary importance. The abstract factors are: initial soil condition, shape of the implement, movement of the implement and final soil condition. These factors are called abstract factors because they are not defined quantitatively. Another factor to be considered while designing tillage tools are the forces acting on the tillage tool which magnitude can be determined by instrumentation. Various forces such as horizontal force, vertical force and side force act on the tillage tool. The resultant of these forces, plus weight of the tillage tool, and parasitic forces if available is called pull. From equilibrium conditions, the pull  $P$  that is required to move the wheel must be equal in magnitude but opposite in direction, to the sum of the horizontal components of all forces in the contact surface. Pull is multiplied by the speed of the tillage tool to obtain the power requirements of the tillage tool.

In order to evaluate the power requirements of the three-bottom mounted moldboard plow, three-disk mounted disk plow and mounted tandem disk harrow, the following parameters were studied: type of soil and moisture content; depth and width of cut; speed of operation; slippage and travel ratio; drawbar pull; effective field capacity; and soil volume worked.

### Type of Soil and Moisture Content

The type of soil has profound effect on the performance of tractor/implement combination. Clay soils offer more shearing resistance to the tillage tools as compared to that offered by sandy soils. The reaction of the soils of forces applied by tillage tools are affected by the resistance of the shear, adhesion and frictional resistance. As the tool advances, the soil in its path is subjected to compressive stresses which in a friable soil result in a shearing action. Shear strength composed of cohesion and internal friction has an important influence on a draft of a tillage tool. From Coulomb's equation for shear strength it is obvious that shearing stress of cohesive frictional soils is greater as compared to that of frictional soil. It is, therefore, imperative to determine the type of soil for the test plot. The soil samples were brought to the Department of Agricultural Chemistry, Sind Agriculture University, Tandojam to analyze the soil samples which turned out to be clay loam.

With any given structure, the soil properties of resistance to compression and shear, as well as friability, plasticity and stickiness depend upon moisture content which is the most important soil factor contributing to soil-metal friction. At low moisture content, the soil is hard and very coherent because of cementation effect among the dried particles. As the moisture content increases, water

molecules are adsorbed on the surface of the particles and decrease the coherence and impart friability to the soil mass. The zone of friable consistency represents the range of soil moisture in which conditions for tillage are at an optimum. Soils are usually in good tilth when they are friable. The individual granules are soft, cohesion is at a minimum. There is sufficient moisture between individual particles to minimize the cementation effects that are dominant in the zone of hard consistency. Nichol (1931) divided soil moisture content into three phases: friction phase, adhesion phase and lubrication phase.

In friction phase, adhesive forces are small and the coefficient of friction is essentially independent of moisture content. Soils in friable condition usually have moisture content in this range. Moisture content in this phase is 0-10% in silt loams and 0-15% in silty clay loams. In the adhesion phase, moisture films develop between the soil particles and metal thus creating adhesive forces that cause apparent coefficient of friction to increase rapidly with moisture content. When the soil has enough moisture to act as lubricant, the coefficient of friction decreases as more water is added.

In order to evaluate the moisture content of the experimental plot, the soil samples were collected before plowing and weighed in a physical balance and dried in an oven for 24 h at 108°C after which the soil samples were

Table 1 Moisture Percentage on Dry Weight Basis

S.No.	Depth (cm)	Wt. of wet sample + Container (g)	Wt. of dry sample + Container (g)	Wt. of Container (g)	Wt. of wet soil $W_w$ (g)	Wt. of dry soil $D_w$ (g)	Wt. of Water (g)	Moisture % $Mc = \frac{[(W_w - D_w)]}{D_w} \times 100$
1	5	164.6	152.9	31.6	133	121.3	11.7	9.6
2	15	144.9	129.0	30.1	114.8	98.9	15.9	16.07
3	10	118.0	107.0	31.5	86.5	75.5	11.0	14.56
4	20	144.3	126.4	31.3	113.0	95.1	17.9	18.82
5	25	137.5	118.6	30.4	107.1	88.2	18.9	21.42

re-weighed and moisture content was calculated (Table 1).

### Depth and Width of Cut

The depth and width of cut are factors that may affect draft and energy utilization efficiency for a specific soil type. The effects of these parameters vary with different types of soils. The width of cut was measured with steel tape and the depth of cut with half-meter scale.

### Speed of Operation

The speed of operation has profound effect on tractor implement performance. The maximum permissible forward speed is related to such factors as the nature of the operations, condition of the field and amount of power available. Increased forward speed increases the draft with most tillage implements because of the rapid acceleration of any soil that is moved. The soil thus accelerated produces acceleration forces that increase normal loads on soil engaging surfaces, thereby increasing the frictional resistance. In order to evaluate the speed, a distance of 43.5 m was measured and ranging poles at the two ends of the measured distance were fixed, the speed was calculated from the formula:

$$\text{Speed (m/s)} = \frac{43.5 \text{ m test run}}{\text{time taken for test run (sec)}}$$

$$\text{Speed (km/h)} = \text{Speed (m/s)} \times 3.6$$

### Slippage and Travel Ratio

The slip of the driving wheel defines the magnitude and efficiency of tractive performance. Slip (travel reduction) of the drive wheels is the primary independent variable. Both tyre efficiency and dynamic ratio are the direct functions of the amount of slip of the drive wheels. Dynamic ratio may range up to 0.80 at 15% slip on concrete to (as low as) 0.30 at

approximately 30% slip in sand. Slip is calculated from the following formula:

$$\text{Slip \%} = 100 \frac{(1 - A_s)}{S_o}$$

where,

$A_s$  = Actual travel speed in miles/h with load

$S_o$  = No load travel speed

or

Slip % = [100 (Wheel revolutions with load - Revolutions without load)] / (Wheel revolutions with load)

Slip % = [100 (Distance travelled without load - Distance travelled with load)] / (Distance travelled without load)

Slip % = [100 (velocity without load - velocity with load)] / (Velocity without load)

Travel ratio = (No. of revolutions without load) / (No. of revolutions with load)

Slip is expected to increase with increasing load. Power efficiency decreases as slip increases. To evaluate the slippage of the rear wheel drive tractor on loamy soil at Latif Farm, the Sind Agriculture University, Tandojam was selected. A 43.5-m distance was measured and the tractor without load and with load was run over the distance. The revolutions without load and with load were counted and recorded to calculate the wheel slip.

### Drawbar Pull

Pull is the total force exerted by the prime mover (tractor) or power unit on the implement. In tillage implements, the pull is generally at some angle above the horizontal, and it may or may not be in a vertical plane parallel to the line of motion. Pull also defines both the magnitude and effi-

ciency of tractive performance. The pull is affected by the depth of cut, width of cut, tool shape, tool arrangement, type of soil, moisture content and travel speed. Various methods have been developed to measure drawbar pull of tillage implements. Clyde (1936) developed a tillage meter to measure the pull force of the implements. In tillage meter the tool is attached to a triangular subframe by six hydraulic dynamometers. However, the tillage meter was obsolete and also not available at the campus.

Scholtz (1966) developed a three-point linkage dynamometer for restrained linkages which could measure vertical and draft forces but not the side force which was also not suitable for use with any mounted implement without modification. Godwin (1975) developed an extended octagonal ring transducer for use in tillage studies which is only capable of providing information on forces in horizontal and vertical direction and the moments about the lateral axis. Perumpal et al (1980) developed a matrix procedure for analyzing the data from multiple degree freedom dynamometer to obtain the forces and moments on the tillage tool. The coefficient matrix procedure can be effectively used to determine the three dimensional force and moment components on a tillage tool during soil tillage interaction studies. As the methods of measuring the forces on the tillage tool described herein were not available, the pull type hydraulic dynamometer was used instead. To facilitate the measurement of pull of the mounted implements under test, the RNAM Test Code was utilized.

### Effective Field Capacity

The effective field capacity represents the actual average rate of coverage in hectares or acres per

hour by the machine and is the function of the rated width of the machine, the percentage of rated width actually utilized, the speed of travel and the amount of field time lost during the operation. The effective field capacity is calculated from the formula:

$$C = \frac{SWE_f}{C}$$

where,

C = Effective field capacity ha/h (a/h)

S = Speed of travel km/h (mph)

W = Rated width of implement, m (ft)

E<sub>f</sub> = Field efficiency, as a decimal

C = Constant, 10 (8.25)

The field capacity is influenced by the field operational pattern which is closely related to the size and shape of the field, kind and size of the implement. Time efficiency is the most difficult variable to evaluate in relation to field capacity. Field time may be lost as a result of adjusting or lubricating the machine, breakdowns, clogging, turning at the ends, adding seed, fertilizer, unloading harvested products and waiting for crop transport equipments. In relation to effective field capacity lost time does not include time for setting up the machine.

### Volume of Soil Disturbed

The volume of soil worked is the criterion of implement performance and is the product of depth of cut and field capacity, which is why width and depth of cut were measured in situ.

### Power Requirements

In many cases, tillage operation used in seedbed preparation operations can be done by different machines. Power requirements of these machines vary greatly.

Knowing these power requirements will assist in selecting an implement for doing a given job. The power needed to operate tillage machines is measured with drawbar dynamometer, a device hitched between a tractor and a pull type farm implement. The dynamometer records force needed to figure the horsepower necessary to operate the machine being tested.

Power can be defined as being equal to the force (pull) required to pull a machine, multiplied by the distance travelled and divided by the time necessary to cover that distance:

$$\begin{aligned} \text{Drawbar power} \\ &= \frac{\text{Force} \times \text{Distance}}{c} \end{aligned}$$

$$\text{DBP} = \frac{FS}{c}$$

where,

DBP = Drawbar power, kW (HP)

F = Force (pull), kN (lb)

S = Forward speed, km/h (MPH)

c = Constant, 3.6 (375)

In using a drawbar dynamometer to test the average power requirements of a machine, it is necessary to determine the distance traveled in a test, the time required and the average force or pull.

Several factors influence the power required to pull various machines. These include size of the machine, depth and width of operation and travel speed. It is generally recognized that more power is required to till fine textured soils, (clay soils) than coarser soils (sandy or loam soils). Soil moisture content and the slope of the land also affect power requirements for tillage operations. For these reasons, power requirements for tillage vary from area to area.

## Results and Discussion

Power requirements of tillage implements are very important from the design point of view. The strength and rigidity of the implements and the size of the power unit (tractor) depend on power requirements.

The power requirements of tillage implements are dependent variables of soil moisture content and type of soil. Therefore, the soil moisture content of the test plot was determined on dry basis. The data pertaining to soil moisture was collected and analyzed (Table 1) showing that the average moisture content was within acceptable range for plowing the land.

Slip or travel reduction is the factor which determines the magnitude level of tractor performance which was determined in the test plot for three different speeds. Data pertaining to slip was collected and analyzed (Table 2). The slip in third gear for three-bottom mounted moldboard plow was 16.7%. It is also obvious from Table 2 that the slip increased as the load was increased. Hence, the present results agree with the conclusions of Frank (1972). The travel reduction for three-disc mounted disc plow in third gear was 27.3%. This was also within acceptable range because maximum drawbar power can develop at 30% slip after which it drops down. The slip for light tandem disk harrow in 3rd gear speed was 8%. Gill and Vanden Berg (1962) conducted tests with sections of moldboard plow bottoms having widths of 2, 4, 6 and 8 inches and taking cuts 1 to 8 inches wide in a silty clay loam soil at the National Tillage Machinery Laboratory, Auburn, Alabama, U.S.A. The specific drafts for the 2-inch and 1-inch cuts were 40% and 140%, respectively, greater than the average for the 4-inch, 6-inch and

**Table 2** Summary of Study Results

Implement	Gear	Slip	Travel ratio	Speed (m/s)	Depth of cut (cm)	Width of cut (cm)	Effective field capacity (ha/h)	Volume of soil worked (m <sup>3</sup> )	Pull (kg)	Power (kg m/s)	Power (kW)
Mold board plow 3-bottom 0.556 m mounted	1	9.1	0.9	0.543	14.8	86.6	0.13	192.4	552.0	299.73	2.939
	2	13.1	0.87	0.725	13.3	88.6	0.18	239.4	577.0	418.325	4.103
	3	16.7	0.83	0.96	16.0	87.6	0.24	384.0	623.0	598.08	5.866
Disc plow 3-disk mounted	1	16.7	0.83	0.48	16.0	110.0	0.15	240.0	568.0	272.64	2.674
	2	23.1	0.76	0.621	23.0	118.0	0.21	483.0	689.0	427.9	4.197
	3	27.3	0.72	1.08	17.0	111.0	0.34	578.0	749.0	808.9	7.934
Disc harrow mounted	1	4.8	0.95	0.67	10.3	103.6	0.20	206.0	189.0	126.6	1.242
	2	4.8	0.95	1.08	9.66	102.6	0.30	299.6	211.0	227.88	2.235
	3	6.9	0.93	1.24	13.8	103.0	0.36	468.0	251.0	311.24	3.053

8-inch cuts. The effect of depth upon the specific draft of moldboard plows is influenced by the shape and size of the plow. Most available evidence indicates that the specific draft generally decreases as the depth is increased to some optimum depth/width ratio and is increased as the depth is increased further. The initial decrease of specific draft with increased depth is logical because the total force for cutting the bottom of the furrow slice should be independent of depth. The increase in specific draft beyond the optimum depth is probably due in part to chocking of the thick furrow slice in the curvature of the moldboard.

Results from a limited number of soil tests in sand indicate that for this one soil condition, varying the width of cut with a 12-inch bottom and a 16-inch bottom had little effect on the specific draft for the bottom alone.

McKibben and Reed (1952)

consolidated speed versus draft test results. They plotted percent increase in draft as a function of speed taking the draft at 3 mph as 100% in each case. The results indicate that there was a 25% increase in draft when speed was changed from 2 to 4 mph and 50% increase when speed was shifted from 3 to 6 mph. This is due to acceleration forces which occur during high speed. **Table 2** also reveals the same trend that with the increase in speed the pull is also increased.

#### REFERENCES

1. Nichols, M.L. 1931. The dynamic properties of soil: An explanation of the dynamic properties of soils by means of colloidal fills. *Agricultural Engineering*, 12. July.
2. A.W. Clyde. 1936. Measurement of force on soil tillage tools. *Agricultural Engineering*, Vol: 17 No. 1 January.
3. D.C. Scholtz. 1966. A three point linkage dynamometer for retrained linkage. *Journal of Agricultural Engineering*. Research, Vol. 1.
4. Feuerlein, W.E. 1968. Tillage tools and their effects including disc and moldboard ploughs. *Suppl. to Modern Farming*, June, 15, 17.
5. R.J. Goldwin. 1975. An extended octagonal ring transducer for use in tillage studies. *Journal of Agri., Engg. Research*, Vol. 20.
6. J.V. Perumpral, L.C. Chance, F.R. Woeste, C.S. Desai. 1980. A matrix method force and moment analysis on a tillage tool. *Transactions of the ASAE*, Vol. 23, No. 5.
7. Smith, J.A. and K.J. Fornstorm, 1980. Energy requirements for selected dry land wheat cropping systems. *ASAE. Trans.* 23(4): 822-825, 830.
8. Sheikh, G.S., J. Sial and M. Afzal 1980. Disc harrow — an appropriate tillage implement. *Proceedings of First Annual convention of PSAE, Lahore*, 182-192. ■■

# Design, Development and Evaluation of Power Tiller-drawn Seed-cum-Fertilizer Drill

by  
A.C. Varshney  
Project Coordinator  
Power Tiller Scheme  
Central Institute of Agric. Engg.  
Bhopal, India

C.P. Bohra  
Scientist S-1  
Central Institute of Agric Engg.  
Bhopal, India

S. Narang  
Scientist S-2  
Power Tiller Scheme  
Central Institute of Agric. Engg.  
Bhopal, India

## Introduction

The power tillers were introduced in Indian agriculture in 1960 through imports against yen credits from Japan. These were primarily conceived as a source of farm power for rotary tilling and, to some extent, for transport. Until recently, the only attachments provided with the power tiller were rotary tiller and trailer and, in some cases, mouldboard plough and ridger (Pandey et al). Due to limited number of implements, the power tiller owner had to maintain a pair of bullocks also, and, therefore, the power tiller could remain only as a supplementary source of power with very little impact on mechanization of Indian farming. This limited annual use also adversely affected the operational economics of power tillers.

To increase the annual use of power tillers, it is essential to develop the matching implements. Further, the development of matching implements would lead to timeliness of operations and in-

---

**Acknowledgements:** The authors express their gratitude to Dr. T.P. Ojha, Director, Central Institute of Agricultural Engineering, Bhopal, India for his able guidance and encouragement. The help extended by Shri MPS Chauhan, Technician, Power Tiller Scheme, Central Institute of Agricultural Engineering, Bhopal in field evaluation is likewise acknowledged.

crease in the command area of the power tiller. Keeping these facts in view and the role of seed-cum-fertilizer drills in proper placement of seed and fertilizer and their subsequent effects on productivity, a power tiller drawn seed-cum-fertilizer drill was developed at the Central Institute of Agricultural Engineering, Bhopal, India.

## Design Considerations

Much of the area in the state of Madhya Pradesh falls under black soils with a high clay content. The common crops grown in these soils are sorghum, Bengalgram, wheat, soybean and pigeon pea. Therefore, the furrow openers of the seed drill should be such that they do not clog during operation and the metering mechanism should be able to meter the seeds of the common crops accurately.

Normally a 8-10 hp power tiller is able to generate 80 to 100 kg draft in well prepared soils at a speed of 2 to 3 km/h. Therefore, the size of the seed drill should be such that the power tiller is able to pull it without excessive slip. Further, the height of the unit should be such that it should not cause any inconvenience to the operator in using the controls and the seed-cum-fertilizer drill should be easily maneuverable.

## Constructional Details

The unit mainly consists of the main frame, seed and fertilizer box, fluted roller type metering mechanism, ground-wheel, furrow openers, depth adjustment mechanism, hitch, etc (Fig. 1). The specifications of the main components of seed-cum-fertilizer drill are given in Table 1.

## Hitching Arrangement

Considering the factors like balancing and stability of the matching unit, maneuverability especially at turns and location of hitch point of the power tiller, a hitching arrangement as shown in Fig. 1 was developed. The hitching arrangement consists of power tiller hitch point, swivel pin and seed drill hitch bracket. Swivel action of the hitch facilitates easy turning. The clearance provided between the power tiller hitch point and hitch bracket takes care of slight vertical misalignment of the seed drill with the power tiller.

## Declutching Arrangement

A dog clutch has been mounted on the fertilizer feed shaft to engage or disengage the drive from the ground wheel to the metering mechanism. The dog clutch is actuated by a quadrant and latch arrangement such that the lifting of furrow openers and disengage-

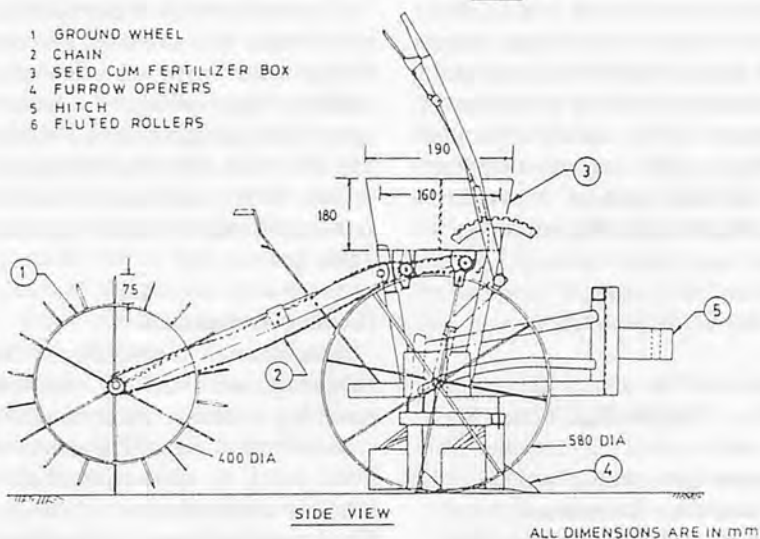
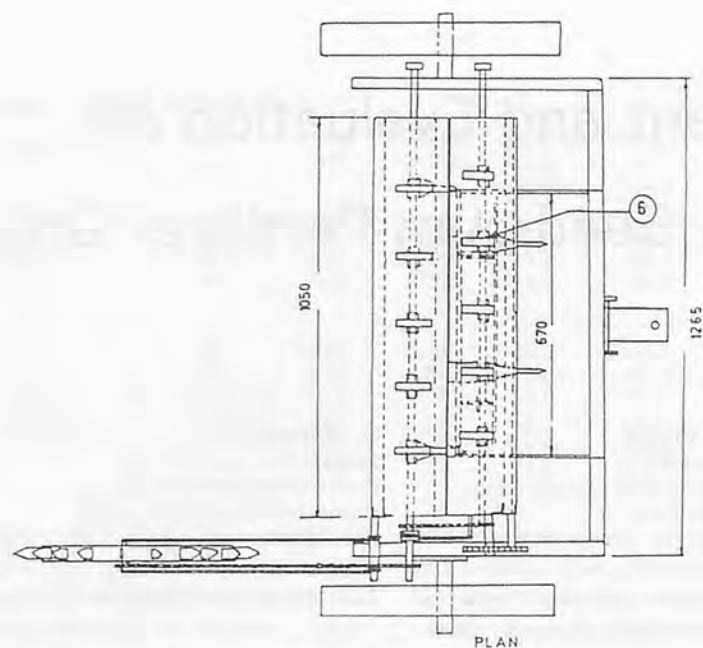

Fig. 1 Field operation of BRR1 weeder.

Table 1 Specifications of Main Components of Seed-cum-fertilizer Drill

Component	Specifications
Specifications	
Length	: 1,625 mm
Width	: 1,630 mm
Height	: 860 mm
Weight	: 160 kg
Seed-cum-fertilizer box	Trapezoidal, length 1,050 mm, top width 190 mm, bottom width 160 mm, height 180 mm
Transport wheel	Flat, 580 mm diameter
Ground wheel	Spiked, 550 mm diameter
Furrow openers	2-5, depending on row to row spacing of the crop, chisel type, 150 mm long with provision for separate seed and fertilizer delivery.
Power transmission	Chain and sprocket type
Depth control	Linkage actuation by quadrant and latch
Seed and fertilizer metering	Fluted roller with adjustable opening.
Declutching of seed and fertilizer metering system	Dog clutch with quadrant and latch

ment of power to the metering mechanism are simultaneous.

### Laboratory Testing

The seed cum fertilizer drill was tested under laboratory conditions by metering wheat, Bengalgram, soybean, sorghum seeds and DAP and Gromor fertilizers for uniformity of distribution in different rows, mechanical damage to the seeds and capacity of the mechanism to achieve the desired seed and fertilizer application rates.

The test results (Table 2 through 4) show that maximum deviation of seed and fertilizer delivery from different furrow openers was 4.0 and 4.5% of average seed and fertilizer delivery, respectively, which is within the permissible limits specified by the Bureau of Indian Standards. As seen from Table 3, the mechanical damage was observed only in Bengalgram seeds with a visible damage of 1.2%. The capacity of the seed drill was sufficient to accommodate the recommended seed and fertilizer application rates for the crops of the region.

### Field Evaluation

The seed-cum-fertilizer drill was tested for its performance for sowing wheat, Bengalgram, soybean, sorghm and pigeon pea crops and was compared with CIAE 3 row animal-drawn seed-cum-fertilizer drill (Dubey et al) under statistically designed experiments. The test results with regard to effective field capacity, plant emergence, yield etc. are presented in Table 5.

The data indicate that the field capacity of the power tiller-drawn seed drill was about 55% higher for wheat and 24% higher for Bengalgram than that of animal-drawn seed drill. This was due to



greater numbers of rows covered by the power tiller-drawn seed-cum-fertilizer drill. No appreciable difference was observed in field efficiencies of both seed drills. The plant population was high in power tiller-drawn seed drill for all the crops mainly due to skidding of the ground wheel of animal drawn seed drill which affected the seed rate. Skidding of ground wheel of animal-drawn seed drill was caused by the choking of fertilizer metering system which restricted free movement of the ground wheel. This problem was not encountered in the power tiller-drawn seed drill due to heavier ground wheel with greater number of spikes.

The yield of all crops was greater for the case of power tiller seed-cum-fertilizer drill as compared to bullock drawn seed-cum-fertilizer drill mainly due to higher plant population and proper drilling of fertilizer.

**Table 2** Data Showing Uniformity of Distribution of Seed and Fertilizer from Different Furrow Openers  
(Number of revolutions of ground wheel — 25)

Seed/ fertilizer	Weight from different furrow openers, g					Average
	1	2	3	4	5	
Wheat	254	260	261	242	244	252
Bengalgram	230	235	236	225	—	232
Soybean	263	—	272	—	259	265
Sorghum	263	—	269	—	259	264
DAP	370	375	382	354	362	368
Gromor	184	187	191	175	177	183

**Table 3** Mechanical Damage to Seeds from Various Furrow Openers

Seed	Mechanical damage from different furrow openers, %					Average
	1	2	3	4	5	
Wheat	0	0	0	0	0	0
Bengal gram	0.2	0.5	0.6	3.5	—	1.2
Soybean	0	—	0	—	0	0
Sorghum	0	—	0	—	0	0

**Table 4** Capacity of Seed-cum-fertilizer Drill for Metering Different Seeds and Fertilizer

Seed/ fertilizer	Row spacing cm	Seed and fertilizer application rate, kg/ha	
		Zero setting of fluted roller	Full setting of fluted roller
Wheat	22.5	3.32	389
Bengal Gram	30.0	0	274
Soybean	45.0	0	159
Sorghum	45.0	2.83	151
D A P	22.5	38.6	1,169

**Table 5** Test Results of Power Tiller Seed-cum-fertilizer Drill and Animal-drawn Seed-cum-Fertilizer Drill

Parameter	Power Tiller Seed Drill					Animal-drawn Seed Drill			
	Wheat	Gram	Soybean	Pigeon pea	Sorghum	Wheat	Gram	Soybean	Sorghum
Soil moisture, % (db)	18.4	17.5	19.0	15.0	19.2	18.4	17.5	19.2	19.1
Size of machine, cm	5 × 22.5	4 × 30	3 × 45	2 × 90	3 × 45	3 × 22.5	3 × 30	3 × 45	3 × 45
Speed of operation, km/h	2.30	2.40	2.38	2.45	2.35	2.80	2.75	2.55	2.50
Effective field capacity, ha/h	0.140	0.155	0.185	0.210	0.187	0.090	0.125	0.180	0.180
Field efficiency, %	54.1	53.8	57.6	47.7	59.0	47.6	50.5	52.3	53.3
Depth of seed placement, cm	6.8	7.0	6.2	5.0	6.0	5.0	5.1	5.1	5.0
Depth of fertilizer placement, cm	7.0	7.1	6.5	5.1	6.1	5.2	5.3	5.3	5.2
Plant population, No/ha(million)	1.98	0.71	0.65	—	0.29	1.89	0.69	0.57	0.28
Viability of seed, %	90	95	74	95	88	90	95	74	88
Average plant emergence, %	84.0	89.6	68.0	—	73.0	83.8	89.2	69.0	72.5
Yield, g/ha	39.29	20.43	12.39	—	36.53	37.36	17.35	12.12	33.64

## REFERENCES

1. Dubey, A.K. and Srivastava, N.S.L. (1985), Development of furrow-openers for animal-drawn seed-cum-fertilizer drill for black soils. Proc. ISAE SJC Vol 1, II-39-45. Central Institute of Agricultural Engineering, Bhopal, India.
2. Pandey M.M, Bohra, C.P., Maheshwari, R.C. and Tomar S.S. (1983). Power Tillers and Matching Implements. Technical bulletin No. CIAE/PTS/83/19. Central Institute of Agricultural Engineering, Bhopal, India.
3. IS: 6813-1973. Seed cum fertilizer drill. Indian Standards Institution, New Delhi. ■■

# Small Power Unit, Equipment and Service Units — Needs, Structures and Problems

by  
Lozan G. Stoimenov  
Reader/Assoc. Prof.  
Dept. of Agric. Engg.  
Anambra State Univ. of Technology  
P.M.B. 01660, Enugu  
Nigeria

## Abstract

The paper concerns small units of tractors and small units for agricultural equipment service which provide facilities for mechanization in small farms. Problems of ownership, relations with farms and middle-scale companies for agricultural mechanization, planning and profitability of these small units are discussed.

## Introduction

All over the world the basic need of small power, equipment and service units is determined by this simple fact that small farms play remarkable role in total amount of agricultural production. There are two methods of mechanizing works in such farms.

The first is to equip the farm with small power machines and various implements. The main advantages of this method pertain to the management and planning of the works. The owner of the farm and implements also owns the power machines and this eliminates the need for coordination about terms, quality, quantity, etc. of mechanized works in the farm. Usually, the cost of the equipment for one farm is not very high, but its relative cost per unit

of farm area can vary by country. This method can point out the low level of productivity of the small power machines and high level of technological skills of individuals who have to use this kind of equipment.

The second method to mechanize works in small farms is based on hiring agricultural equipment or payment for mechanized work to company, organization, etc. who own the equipment. The main advantage of this method is that it gives possibility to use powerful tractors with high level of productivity and mechanized works are made by qualified personnel. Generally, for farm, it is better to hire tractors instead of owning them if the farm is small. Even for large farms the hiring of tractors and implements can be more profitable than owning them.

## Farm Structures

### Power Units

The simplest and smallest farm unit which is able to supply service, has to possess at least one tractor. With respect to the staff of such a unit it is really small scale business. A well qualified tractor driver can be the whole staff of the unit. But if consideration is with

respect to the cost of the equipment, then even a single tractor unit cannot be considered as a small scale business. In Nigeria, for example, the total cost of a tractor and implements is more than US\$40,000 (₦200,000). In spite of this fact every unit which includes less than 5-6 tractors can be considered as a small one. Generally, as a small power unit can be considered every unit needs no workshop for complex maintenance and repairs. The structure and relations of a small power unit with farms which it serves are shown in Fig. 1. The head of the unit is the owner or manager. In some cases, he can be also a mechanic who organizes the unit maintenance. The unit needs a car for transport and as mobile workshop. For the maintenance and emergency repairs a spare parts store has to be organized.

The area on which the unit operates is external to the structure of the unit, but it is very important to determine this area. There are several ways of evaluating its size. The most important evaluation is based on required revenue which has to guarantee sinking fund, expenses for fuel, maintenance, salaries and some profit. For one year let the sinking-fund for one tractor with its implements be F, the average price which the

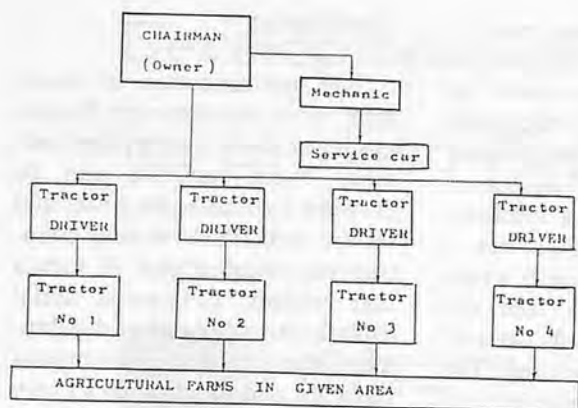

Fig. 1 Structure of a small power unit.

farmers are ready to pay for mechanized work on 1 ha be  $P$ , and average expenses, including tractor drivers wages per hectare be  $S$ . If the unit has  $N$  tractors, the annual salaries of the manager and the mechanic are  $A_1$  and  $A_2$ , and standard profit is  $Q$  then the total area which the unit has to work on is as follows

$$W = \frac{N \times F + A_1 + A_2 + Q}{P - S} \quad (1)$$

Taking roughly the present conditions in Nigeria (in US dollars)  $F = 4000$ ,  $A_1 = 3000$ ,  $A_2 = 2000$ ,  $Q = 16000$  (for  $N = 4$ ),  $P = 40$ , and  $S = 10$  for  $N = 4$  formula (1) gives 1233.3 ha or approximately 310 ha annually per tractor.

Another way to evaluate the area which the unit has to operate on is to analyse farmers' needs and their annual plans of farm operation. Each farmer has to present in his order data about terms of works and their amount in accordance with his own plan of use of the land. The data can be presented in a form as shown in Fig. 2. As actual interval of the optimal implementation of a given work depends on natural random factors, it means that the annual plan of the unit contains random variables. In spite of this the maximal daily and weekly productivity of each tractor is not random. This means that there is a limit to the

Work	Interval to begin		Interval to finish		Amount ha	Requirements & Priorities
	From	To	From	To		

Fig. 2 Form for presentation data of required works.

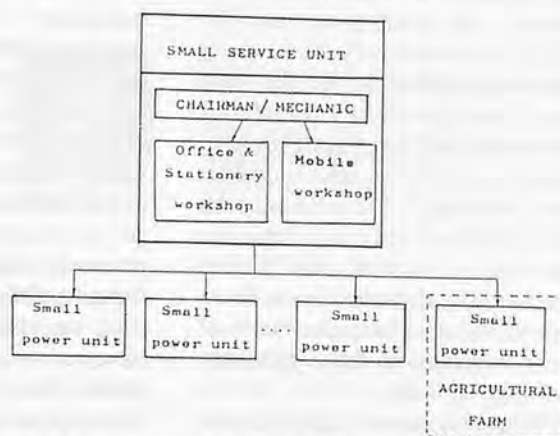

Fig. 3 Structure and relations of a small service unit.

total amount which the unit can do in a given interval of time. Such kind of limits can be used to find the list of farms for which the unit is able to provide real service.

### Service Units

All farm operations which the maintenance of a tractor and agricultural equipment needs can be classified for simplicity. The operations of every day and short-time maintenance and service are simple, hence the tools and service equipment required. Most of this equipment is compulsory for every tractor and is supplied by manufacturers together with the tractor and equipment.

The next level of maintenance and service relates to more special works, which need special qualification and special equipment and tools. For example, adjustment of engines, clutches, brakes, front wheels, etc. control for exhaust gases, control adjustment and repair of electrical system, some welding works, etc. can be done in a small service unit that is proper-

ly equipped.

Such a kind of unit really can be a small scale business for specialists who have B. Eng. or HND in mechanical or agricultural engineering and have some experience in maintenance and service.

One small scale service unit has to be related with several small power units (Fig. 3). It can be either independent enterprise or a component of a middle or large scale company dealing with agricultural engineering.

### Problems

The main problem which hinders the development of small scale power and service units is the initial capital to be invested in these businesses. The high level of prices of tractors and implements in developing countries with respect to prices of agricultural production and raw materials which makes these countries, export difficult to generate enough

money even for establishment of a small scale power unit. Only very rich people can afford to buy few tractors but they have many reasons to try to put their money in other areas. In this situation the only way to develop any scale of power units are the governmental investments to enable the government to set small power units or the Government will lend money for this purpose. In the first case small power units can be included in middle and large scale governmental enterprises and be under their authority. The initial capital for a small service unit is less than this for the power unit, but its profitability depends on the number of these units and scheme of their possession and administration.

The second problem is the ratio between fees which the small scale units (power and service) could get for a unit work and expenses to do it. Generally, this ratio depends on the level of fees which would encourage farmers to

look for help from power units. This problem is very important in developing countries where the cost of the equipment is high while the cost of labour is low. In addition, there is a lack of experience in the use of agricultural mechanization in developing countries.

In these circumstances it is very important to ensure that the equipment and, especially the tractors would be fully utilized. The first things to attain high level of use for tractors is a proper plan of works: annual, monthly and actual (for the next week and even for the next day). The problem of planning in agriculture is very serious and difficult due to many random variables which in the plan have to be taken into account. It means that for long term plans statistical modelling has to be used which requires the use of a computer and proper algorithms of the modelling. But two problems arise: availability of a computer and qualification of the managers of the units.

## Conclusion

The mechanization of small-scale farms requires very flexible system of power and service facilities. These facilities can be provided by small-scale power and service units. In developing countries the establishment of such a unit requires substantial initial capital. An alternative development plan is to use Governmental subsidies and loans given to very well qualified specialists in agricultural engineering and management. Another alternative is the organization of cooperative societies as owners of power and service units for agricultural mechanization. The units have to operate mainly on the base of commercial relations with farmers, but some times in order to improve agriculture these units need governmental subsidies. To help the development of these units educational and research organizations have to design proper educational and research programs. ■■

### COMPUTERIZED AMA INDEX AVAILABLE

A computerized index of technical articles in *Agricultural Mechanization in Asia, Africa and Latin America* has been compiled for the years 1971 through 1989. Each citation includes truncated versions of the title, first and second authors' names and four keywords. Year, issue and page number of each article are given. The citations along with software for searching the database are all included on a single computer diskette for use with IBM-PC, -XT, -AT or compatible type computers.

Anyone wishing to receive this material may send one formatted, 5 1/4-inch, 360 Kbyte, double-sided, double-density diskette to William Chancellor, Agr. Eng. Dept., Univ. of Calif., Davis, CA 95616, USA. The database and searching software will be copied to that diskette, and it will be returned by airmail along with software documentation. There is no charge. Any special customs or postal designation or specifications required should be stated in the letter of request. Annual updates will be available in the future.

# Development of a Low-cost Weeder for Lowland Paddy



by  
Md. Syedul Islam  
Scientific Officer  
Agric. Engg. Div.  
Bangladesh Rice Res. Inst.  
Joydebpur, Gazipur  
Bangladesh



Khondaker Azharul Haq  
Head  
Agric. Engg. Div.  
Bangladesh Rice Res. Inst.  
Joydebpur, Gazipur  
Bangladesh

## Abstract

A low-cost BRRRI weeder\* was developed. Its performance was compared with the Japanese type manual weeder. The performance of the weeders were comparable in sandy loam where weed density was 375 weeds/m<sup>2</sup>. Under identical soil moisture condition (saturation) the average field capacity of BRRRI weeder and Japanese made manual weeders were 0.0351 ha/h and 0.327 ha/h, respectively. However, in clay loam soil (at saturation) the Japanese manual weeder did not work at all due to clogging of sticky clay which rendered the spikes inoperative. Under similar soil conditions BRRRI weeder performed satisfactorily with a field capacity of 0.034 ha/h at saturation and a weed density of 500 weeds/m<sup>2</sup>. Both weeders eliminated 90% of the weeds.

The materials needed for the BRRRI weeder are easily available in the rural areas and can be fabricated by village blacksmiths with their existing facilities. No job of welding or press cutting of sheet metal is necessary unlike with the Japanese type weeder wherein this kind of job has to be done. The simpler fabrication technique

reduced the cost which, on the average, the BRRRI weeder is 35% cheaper than its Japanese-made counterpart. It was also reported by the operators that the BRRRI weeder was easy to operate in comparison with the Japanese type manual weeder.

## Introduction

Timely weeding is one of the most important agricultural operations for increased crop production. Igbeka (1984) indicated that the timing rather than the frequency of weeding was a major determinant of effective weed control for rice. Weeds directly reduce crop yield by competing with the crop in respect of space, sunlight, water and nutrient, and adversely affects the microclimate around the plant, harbour diseases and pests. Weeds increase the cost of production and lowers the quantity as well as the quality of the crop. Depending on the weed density 20 to 30% loss in grain yield is quite usual which may increase to 50% when the crop management practices are not properly followed (Gill et al, 1981). A study in the United States shows that the competition of one grass plant (*Echinochloa crusgalli*) per square foot reduced the yield of rice by

25% (Grist, 1976).

Haq and Islam (1983) in their study found that in lowland rice manual weeding the cost was 21.6% of the total production cost. They reported that the Khurpi (traditional weeding equipment used in Bangladesh) had a very low field capacity of 0.0033 ha/h.

Recommendations have been made for the first weeding to be done 2—3 weeks after sowing, followed by a second weeding three weeks later, and if necessary, a third one (Moomaw, 1971). In irrigated rice fields, rotary weeders have been used with success although some supplementary hand-weeding around the plants may still be necessary. A weeder made of steel was developed in India which showed best performance in the field where 25 mm to 50 mm of water was standing (Boyd, 1976). A manually-operated wetland paddy weeder (Japan origin) was introduced in Bangladesh in 1965. The Comilla Co-operative Karkhana was the pioneer for large-scale production of these type of weeders. It had a field capacity of 0.035 ha/h but needs special skill to fabricate. Moreover, the weeder was not found suitable in certain soils, specially in heavy clay. Due to its high price, its demand declined.

\* BRRRI weeder: The weeder developed at the Bangladesh Rice Research Institute.

The low-cost weeder was designed with the following objectives: i) to reduce cost of weeding as well as the weeder; ii) to reduce draft requirement; iii) to adapt the weeder to varied soil and operating conditions; iv) to use locally available materials; and v) to simplify the manufacturing process.

## Materials and Method

### Design and Construction

It is essential that the width of weeder be smaller than the space between two consecutive rows so that the weeder can be easily operated within the rows. The width of the weeder is dependent on the length of the wooden core. Three different lengths of wooden core were selected: 15 cm, 17 cm and 20 cm depending on row spacings. The effective puddling depth of spikes was 5 cm which is sufficient to destroy most of the weeds. The diameter of the wooden core was 13 cm based on the ease of operation and distance covered per rotation.

The length of the handle was 100 cm that gives an average-sized man to operate it easily. The grip, handle and drive core were made of wood. The frames were made of M.S. flat bar. The axle and spikes were made of iron rod. Three and four spikes were grafted around the wooden core in alternate rows. Theoretically, this arrangement of spikes leaves no space unpuddled within the rows. A prototype of the weeder was fabricated according to Figs. 1 to 5 and its field operation is shown in Fig. 6.

Table 1 lists the materials and cost to fabricate one BRR I weeder which amounts to Tk 114.60. If the cost of fabrication represents 40% of the cost of materials, the total cost would be Tk 143.24 or about US\$ 5.00.

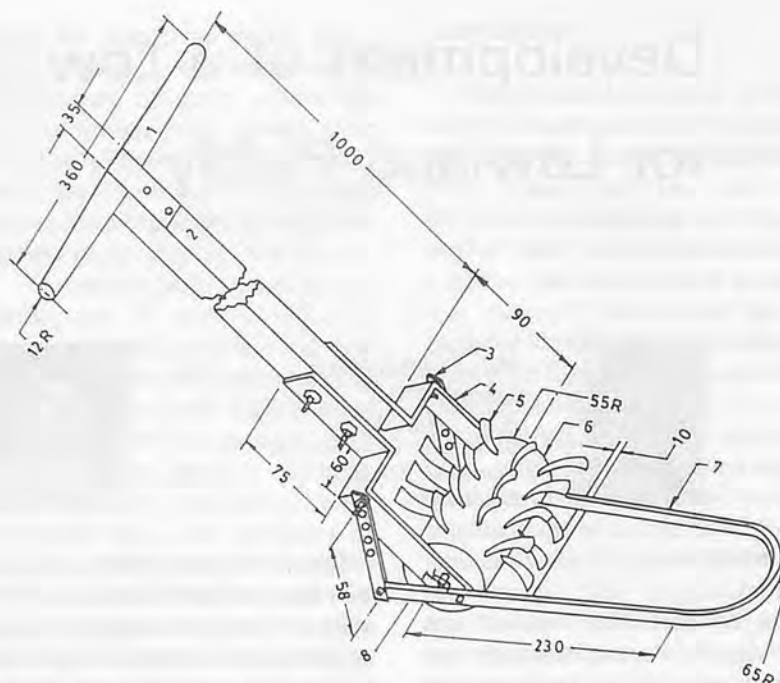

Fig. 1 Push type weeder showing components: 1—Grip, 2—Handle, 3—Gauge bar, 4—Frame, 5—spike, 6—150mm long wooden core, 7—Skid-frame, 8—Axle. Unit: mm.

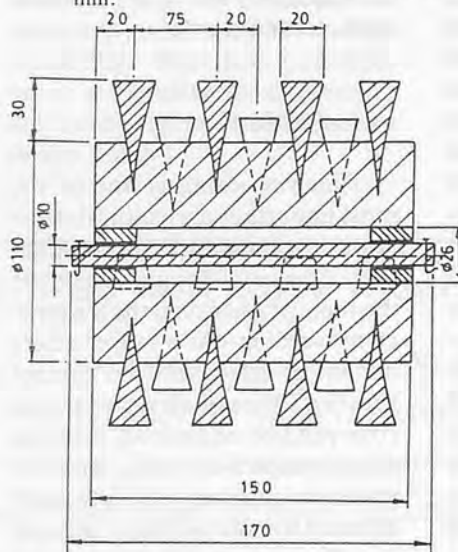

Fig. 2 Longitudinal section of wooden core.

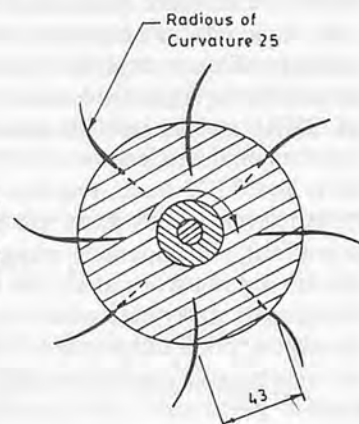

Fig. 3 Cross-section of wooden core.

### Methodology for Evaluation

Tests were conducted in clay loam and sandy loam soil in order to evaluate the performance of the weeder. In clay loam soil with a weed density of 500 weeds/m<sup>2</sup> and at saturation (soil moisture), it was not possible to operate the Japanese type manual weeder due to clogging of the sticky soil into the spikes. Therefore, only the BRR I weeder was tested in clay

soil with four operators (treatments). The treatments were replicated thrice as follows:

- T<sub>1</sub> = BRR I weeder with operator O<sub>1</sub>;
- T<sub>2</sub> = BRR I weeder with operator O<sub>2</sub>;
- T<sub>3</sub> = BRR I weeder with operator O<sub>3</sub>;
- T<sub>4</sub> = BRR I weeder with operator O<sub>4</sub>;

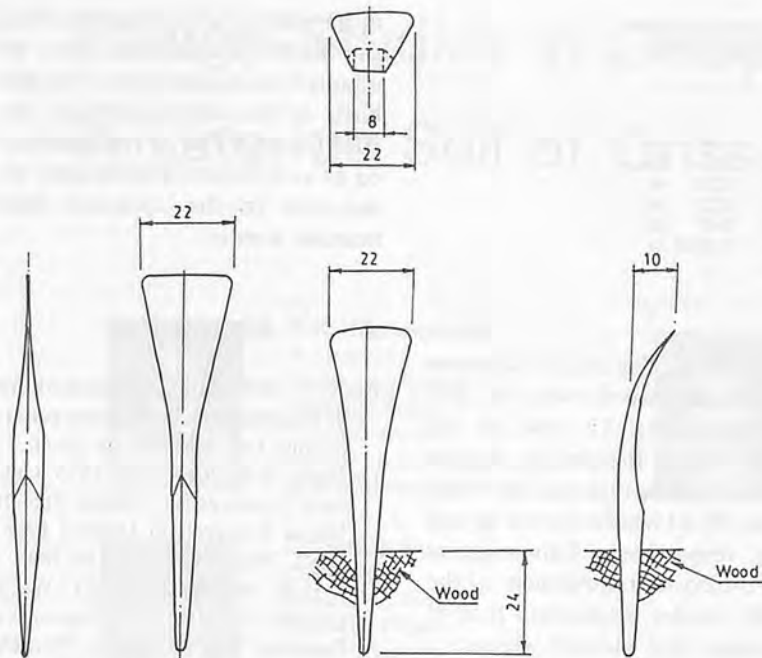

Fig. 4 Spike before bending, a) side view, b) front view.

Fig. 5 Spike after bending, a) front view, b) right-hand view.

Table 1 Materials and Approximate Cost of BRRi Weeder

Name of part	Material	Quantity	Rate	Cost (Tk.)
Wooden core	Jam wood	0.106 cft	Tk. 250/cft	26.50
Handle with grip	Jam wood	0.106 cft	Tk. 250/cft	26.50
Frame	M.S. flat bar	3.5 lbs	Tk. 8.00/lb	28.00
Axle	M.S. rod	0.45 lbs	Tk. 8.00/lb	3.60
Sheet foil	G.I. sheet	1 lb	Tk. 8.00/lb	8.00
Spike	M.S. rod	1 lb	Tk. 8.00/lb	8.00
BUSH	M.S. rod	2 Nos	Tk. 5.00/bush	10.00
Nuts and bolts	Mild steel	4 Nos	Tk. 1.50/piece	6.00
Total				116.60

In order to compare the BRRi weeder with the Japanese type manual weeder in sandy loam soil with a weed density of 375 weeds/m<sup>2</sup> and at saturation, two operators were used. A randomized complete block design was used in the test with four treatments replicated thrice as

follows:

- T<sup>1</sup> = with BRRi weeder (W<sub>1</sub>) and operator O<sub>1</sub>;
- T<sub>2</sub> = with BRRi weeder (W<sub>1</sub>) and operator O<sub>2</sub>;
- T<sub>3</sub> = with Japanese type manual weeder (W<sub>2</sub>) and operator O<sub>1</sub>;

Table 2 Field Capacity of BRRi Weeder in Clay Loam Soil at Saturated Moisture Condition.

Observation	Field capacity (ha/h) by operators			
	O <sub>1</sub>	O <sub>2</sub>	O <sub>3</sub>	O <sub>4</sub>
1	0.0300	0.0366	0.0273	0.0285
2	0.0294	0.0261	0.0429	0.0375
3	0.0375	0.0333	0.0462	0.0333
Average	0.0323	0.0320	0.0388	0.0331

Note: Plot size: 20m × 2.5m; Weed density = 500 weeds/m<sup>2</sup>  
 O<sub>1</sub> = Operator No. 1; O<sub>2</sub> = Operator No. 2;  
 O<sub>3</sub> = Operator No. 3 and O<sub>4</sub> = Operator No. 4

Table 3 Field Capacity (ha/h) of BRRi and Japanese Type Manual Weeder in Sandy Loam Soil at Saturated Moisture Condition

Weeder	Field capacity (ha/h) by operators		
	O <sub>1</sub>	O <sub>2</sub>	O <sub>3</sub>
W <sub>1</sub>	0.0344	0.0358	0.0351
W <sub>2</sub>	0.0318	0.0336	0.0327
Average	0.0331	0.0347	

Note: CV = 18%, Plot size: 16m × 3m, Weed density = 375 weed /m<sup>2</sup>; W<sub>1</sub> = BRRi weeder; W<sub>2</sub> = Japanese type manual weeder.



Fig. 6 Field operation of BRRi weeder.

T<sub>4</sub> = with Japanese type manual weeder (W<sub>2</sub>) and operator O<sub>2</sub>;

## Results and Discussion

The highest and lowest field capacity of the BRRi weeder was 0.0462 ha/h and 0.0261 ha/h with operator O<sub>3</sub> and O<sub>2</sub>, respectively, in clay loam soil with a weed density of 500 weeds/m<sup>2</sup> (Table 2). This difference in field capacities may be attributed partly to the operators and partly to the moisture variation within the field. It was observed that the BRRi weeder performed better if the field had a few mm of standing water.

The average field capacities of the BRRi weeder by operators O<sub>1</sub>, O<sub>2</sub>, O<sub>3</sub> and O<sub>4</sub> were 0.0323 ha/h, 0.320 ha/h, 0.388 ha/h and 0.0331 ha/h, respectively, (Table 2) in clay loam soil with a weed density of 500 weeds/m<sup>2</sup> which were not too different. However,

**Table 4** Analysis of Variance of Field Capacities of Two Different Operators in Sandy Loam Soil at Saturated Moisture Condition

Source of variation	df	SS	MS	F	
Replication	2	0.0000450	0.0000225	0.63	ns
Treatment	3	0.0000251	0.0000084	0.24	ns
Operator (O)	1	0.0000077	0.0000077	0.22	ns
Weeder (W)	1	0.0000173	0.0000173	0.49	ns
Interaction (O×W)	1	0.0000001	0.0000001	0.0028	ns
Error	6	0.0002140	0.0000356		
Total	11	0.0002840			

CV = 18%, ns = Non significant at 5% level.

in clay loam soil the weighted average field capacity of the BRRRI weeder was 0.03405 ha/h.

The average field capacities of the BRRRI and Japanese type manual weeders were 0.0351 ha/h and 0.0327 ha/h, respectively, in sandy loam soil with a weed density of 375 weeds/m<sup>2</sup> (Table 3). Under identical operating conditions; replication, treatment, operator, weeder and the interaction between operator and weeder has showed no significant effect on field capacities at 5% level (Table 4). The insignificant interaction between weeder and operator means that the field capacity of a particular weeder is not dependent on the operator.

The materials needed for fabricating BRRRI weeder are easily available in rural areas. No sophisticated technique like welding and press cutting of sheet metal is necessary for its manufacture. Even village blacksmiths can fabricate it easily with their exist-

ing facilities. The cost of Japanese type manual weeder was Tk. 250 compared with Tk. 164 for the BRRRI weeder. Besides, the weights of the Japanese type manual weeder and BRRRI weeder were 6 kg and 5 kg, respectively. This suggests that the power requirement of the BRRRI weeder is less than that of Japanese type manual weeder.

### Conclusions

The BRRRI weeder performed well both in clay and sandy soil. The Japanese type manual weeder was almost inoperable in clay soil because its spikes were clogged with sticky clay. The power requirement of the Japanese type manual weeder was high as it has two sets of spikes, hence the operators tired quickly. In comparison, the BRRRI weeder has a single set of spikes, hence it is light and its power requirement was comparatively low (as reported by the oper-

ator). With some modifications the BRRRI weeder can also be adapted to upland crops. On the basis of the above analysis, the BRRRI weeder can be recommended as an effective and cheaper alternative to the Japanese type manual weeder.

### REFERENCE

- Body, J. 1979. Tools for Agriculture in Intermediate Technology publications Ltd. London pp 19-40.
- De Datta, S.K.; Ross, V.E. 1975. Cultural Practices for Upland Rice in Major Research in Upland Rice. IRRI, Philippines, pp 160-283.
- Gill, H.S.; Kollar, J.S. 1981. Weed Control in Rice in Progressive Farming. Vol. xii, No.10. Punjab Agricultural University. India, pp 6.
- Haq, K.A.; Islam, M.N. 1981. A study on the Technical and economic profile of Deep Tubewell Irrigation Systems in Gazipur Zone (Unpublished report).
- Igbeka, J.C. 1984. Development in Rice Production Mechanization. AMA 10 (1): 27-32.
- Islam, M.S.; Haq, K.A. 1985. Performance of indigenous hand weeders in Bangladesh. Vol. xvi, No.4, AMA. pp 47-50.
- Moomaw, J.C. 1971. Standard cultural practices for Rice Research IITA, Ibadan, Nigeria. pp 4. ■■



# Energy Studies in Cropping Systems in Lateritic Soil of Orissa, India



by  
**P.K. Mohapatra**  
Agronomist  
Dryland Agriculture  
Research Project  
Orissa University of  
Agriculture and Technology  
Bhubaneswar, India



**P.C. Senapati**  
Agric. Engineer  
Dryland Agriculture  
Research Project  
Orissa University of  
Agriculture and Technology  
Bhubaneswar, India



**D. Satpathy**  
Chief Scientist  
Dryland Agriculture  
Research Project  
Orissa University of  
Agriculture and Technology  
Bhubaneswar, India

## Abstract

The studies were conducted in the 1984 and 1985 rainy seasons under rainfed condition in order to determine the energy utilisation pattern in pigeonpea and rice grown alone and in combination with each other. It was observed that 32 to 50% of the total energy input was consumed in the use of tractor and tractor-drawn implements; 30 to 43% for fertilisers and manures; 5 to 17% for seeds; 2 to 11% for pesticides; 3 to 4% for labour and 0.70 to 1.0% in the use of hand- and manually-operated tools. Harvesting operation utilised about 38 to 60% of the energy in the use of hand tools and 24 to 34% for labour in weeding, and 37 to 41% of the total labour. The cost per every 1000 MJ of energy input was the lowest for tractor and attached implements (\$16.42) followed by hand

tools (\$32 to \$55) and the cost of energy for labour was the highest (\$426 to \$429) warranting small scale mechanisation of agriculture in the developing countries through efficient labour-saving hand tools and bullock-drawn implements.

Energy output was highest ( $134 \times 10^3$  MJ/ha) for pigeonpea and rice intercropping system followed by pigeonpea alone ( $107 \times 10^3$  MJ/ha) which was superior to the rice ( $70 \times 10^3$  MJ/ha) alone along with higher energy output-input and cost-benefit ratios. It is concluded that the rice crop alone may be substituted by pigeonpea or pigeonpea and rice intercropping systems from energy efficiency point of view in rainfed uplands of Orissa.

## Introduction

Orissa is located in the eastern part of India within 17°31' and 22°32' North latitude and 81°31' and 87°37' East longitude. It lies in the sub-tropical belt of medium

pressure. The rainy season lasts for about four months. The average annual rainfall in the State is about 1482 mm of which about 81% is received during June to September (Lenka, 1974). The rainfall is erratic causing intermittent dry spells during crop growing season. Rainy season (kharif) paddy occupies 4.196 million ha constituting 64% of the total cultivated area of which 23.1% is grown in uplands, 41.1% in medium lands and 35.8% in lowlands. The cropping intensity is 146%. The upland rice crop is seriously affected by moisture stress during the dry spells prevailing from 5 to 19 days at various growth stages. Though the average yield of rice is as low as 0.84t/ha, the farmers are unwilling to leave the rice cultivation from upland as it is the main food in the daily diet. Therefore, in view of the erratic weather condition and the food habits of the farmers, research work is going on at the Dryland Research Station of the Orissa University of Agriculture and Technology for yield maximisation through intercropping of rice with pigeonpea.

The progress of mechanization in agriculture is slow due to poor resource base in rainfed farmers. The energy resources of the rural communities are insulated, essentially closed units, due to their

**Acknowledgements:** The authors are thankful to the Indian Council of Agricultural Research for funding the project. They also wish to express their gratitude to Sri Binod Behari Behera for typing the manuscript.

non-monetary economics (Rao et al 1987). The share of non-renewable energy dominates even at present the low level of total input energy in crop production systems in developing countries. The global fossil fuel crisis and rapidly increasing demand for food have made us monitor the energy relationships in the cropping systems to increase the energy use efficiency (Pal et al 1985). As the cost of energy derived from fertilisers, fuel and machinery increases, the optimum economic cropping patterns tend to shift back towards traditional, less energy intensive methods—the rotation of crops or intercropping with nitrogen-rich legumes, the use of livestock manure and the increased use of manpower (Loftness, 1978). Mohapatra et al (1987) reported that the energy output of monocropped rice was much less ( $18.2 \times 10^3$  MJ/ha) as compared to rice-potato; ( $84.3 \times 10^3$  MJ/ha) and rice-wheat rotations; ( $59.0 \times 10^3$  MJ/ha);

## Materials and Methods

The experiment was laid out in a randomized block design replicated four times during 1984 and 1985 rainy seasons in a lateritic soil (Alfisol) of sandy loam in texture with pH 5.3, total N 0.04%, 18 kg available P 125 kg K/ha and EC 3.8 meg/100 g. Pigeonpea cultivar R-60 (180 days) was sown in paired rows at 30 cm spacing with an inter-paired row distance of 90 cm. Five rows of rice cultivar Subhadra (90 days) were sown in the 90 cm interspace. The row ratio of pigeonpea to rice was 2:5 and the land area ratio was 1:0.75. Both of them were also grown as pure crops. Pure rice was given a seed rate of 100 kg per ha and intercropped rice 75 kg per ha. Pigeonpea was sown at 20 kg per ha in

order to maintain its population as single crop as well as in intercropping system. Nitrogen was applied at the rate of 30, 45, 60 and 75 kg per ha. Full P (18 kg/ha) and K (17 kg/ha) with 10 kg N/ha were applied at sowing uniformly to rice and the intercrops. The rest of the N was applied in two equal splits to rice only after 20 and 40 days of germination. Pigeonpea alone was given a single basal dose of 20-18-17 kg NPK/ha.

## Use of Machinery and Hand Tools

The primary cultivation was accomplished through disking the field once by three-furrow disc plough (320 kg) followed by cultivating twice through a nine-tine cultivator (225 kg) attached to a Ford 3600 model 47 hp tractor. It was uniform for all the treatments. The field was levelled by a *phawra* made of mild steel with wooden handle (2 kg). Lines were drawn for sowing pigeonpea by trench hoe made of mild steel and wooden handle (1.5 kg). Subsequent hilling up and hoeing operations were performed by the trench hoe. Five-tine furrow opener (7.5 kg) was used for opening the lines for sowing rice at 15 cm row spacing. It is an essential attachment to Annapurna seed drill as described by Senapati et al (1988). Hand-compression, low-volume knapsack sprayer (6 kg) made of brass

was used for spraying pesticides while the galvanized iron bucket (2.4 kg) was used for bringing water and making the spray solution. Enamelled iron plates (0.30 kg) were used for seed and fertiliser applications. Weeding sickle (0.04 kg) was used for uprooting the weeds for effective weeding. Rice was harvested from the field with the use of sickles (0.12 kg). The small twigs with pads of pigeonpea were also pruned by the sickles. The pigeonpea plants were cut at ground level by means of a cutting knife (0.70 kg). The pigeonpea pods were sundried and beaten by wooden hammer (2 kg) for threshing the grain. Rice was threshed by a pedal thresher (39 kg). Winnowing for rice and pigeonpea grains was done by a winnower (0.30 kg) made of thin bamboo strips.

The time taken for an event and the source of energy were recorded. The energy input (EI) and energy output (EO) were calculated as prescribed by Mittal et al (1985). The energy output and input ratio (EOIR) was calculated by the following formula:-

$$EOIR = \frac{EI}{EO} \quad \dots(1)$$

where

EOIR = Energy output-input ratio

EI = Energy input (MJ/ha)

and EO = Energy output (MJ/ha)

The unit cost of EI was calculated by

$$UCEI = \frac{EI}{CEI} \quad \dots(2)$$

**Table 1a** Energy Input (MJ/ha) in Different Cropping System

Cropping system	Seeds	Fertilizers and manures	Pesticides	Labour	Tractor and tractor-drawn implements	Hand tools	Total E.I.
Rice	1470 (16.8)*	3786 (43.4)	171 (2.0)	288 (3.3)	2928 (33.5)	83 (1.0)	8725 (100.0)
Pigeonpea and rice intercrop	1397 (15.3)	3786 (41.3)	621 (6.8)	354 (3.8)	2928 (32.0)	77 (0.8)	9163 (100.0)
Pigeonpea	294 (5.0)	1749 (30.0)	621 (10.7)	193 (3.3)	2928 (50.3)	38 (0.7)	5823 (100.0)
Average	1054 (13)	3107 (39)	471 (6)	278 (4)	2928 (37)	66 (1)	7904 (100)

\* Figures in parentheses indicate percentage.

where

UCEI = Unit cost of energy input (\$/MJ)

EI = energy input (MJ/ha)

and CEI = cost of energy input (\$/ha)

Treatments

RN<sub>30</sub> = Rice with 30 kg N/ha

RN<sub>45</sub> = Rice with 45 kg N/ha

RN<sub>60</sub> = Rice with 60 kg N/ha

RN<sub>75</sub> = Rice with 75 kg N/ha

PRN<sub>30</sub> = Pigeonpea and rice with 30 kg N/ha

PRN<sub>45</sub> = Pigeonpea and rice with 45 kg N/ha

PRN<sub>60</sub> = Pigeonpea and rice with 60 kg N/ha

PRN<sub>75</sub> = Pigeonpea and rice with 75 kg N/ha

P = Pigeonpea with 20-18-17 kg NPK/ha

## Results and Discussion

The data for rice and pigeonpea + rice were averaged over for doses of nitrogen over 1984 and 1985 as presented in Tables 1 and 2 along with pigeonpea for ease of interpretation

### Energy Input (EI)

The highest amount of EI was spent for pigeonpea and rice intercropping system ( $9.16 \times 10^3$  MJ/ha) which was marginally higher by about  $0.43 \times 10^3$  MJ/ha (4.70%) over single rice crop and to a great extent of  $3.35 \times 10^3$  MJ/ha (36.60%) over that of lone pigeonpea. Fertiliser and manure accounted for more than 40.00% in case of rice and the intercropping systems whereas tractor and its implements consumed 32.34% of the EI. Isermann (1983) has reported similar findings with respect to fertilisers. These two components consumed about 73.00% to 77.00% energy input. Rice required 78.00% of the EI which was 3.80% more than the intercrops through fertilisers, machinery and hand tools.

**Table 1b** Energy Input (MJ/ha) Through Hand Tools

Cropping system	Phawra	Trench hoe	Five-tyne furrow opener	Sprayer	Bucket	Enamelled plates	Weeding sickle
Rice	5.02 (6.0)*	—	9.41 (11.3)	6.02 (7.3)	0.15 (0.2)	5.11 (6.1)	0.98 (1.2)
Pigeonpea and rice intercrop	5.02 (6.5)	3.38 (4.4)	2.59 (3.4)	9.03 (11.8)	0.23 (0.3)	5.11 (6.6)	1.20 (1.6)
Pigeonpea	5.02 (13.3)	3.38 (8.9)	—	9.03 (23.9)	0.23 (0.6)	5.11 (13.5)	0.60 (1.6)

Cropping system	Sickle	Cutting knife	Wooden hammer	Bamboo winnower	Pedal thresher	Total E.I.
Rice	3.07 (3.7)	—	—	2.41 (2.9)	50.86 (61.3)	83.03 (100.0)
Pigeonpea and rice intercrop	3.13 (4.1)	0.88 (1.1)	10.03 (13.1)	4.82 (6.3)	31.29 (40.8)	76.71 (100.0)
Pigeonpea	0.48 (1.3)	0.88 (2.3)	10.03 (26.6)	3.01 (8.0)	—	37.77 (100.0)

**Table 1c** Energy Input (MJ/ha) Through Hand Tools in Different Events

Cropping system	Sowing	Hoeing and earthing	Weeding	Spraying	Harvesting	Total	Cost of E.I. (\$/ha)	Cost/MJ $\times 10^3$ (\$)
Rice	1954 (23.5)*	—	0.98 (1.2)	6.17 (7.4)	56.34 (67.9)	83.03 (100.0)	2.67	32.16
Pigeonpea and rice intercrop	14.22 (18.5)	1.88 (2.4)	1.20 (1.6)	9.26 (12.1)	50.15 (65.4)	76.71 (100.0)	3.75	48.89
Pigeonpea	11.63 (30.8)	1.88 (5.0)	0.60 (1.7)	9.26 (24.4)	14.40 (38.1)	37.77 (100.0)	2.08	55.07

\* Figures in parentheses indicate percentage.

**Table 1d** Energy Input (MJ/ha) Through Labour in Different Events

Cropping system	Plowing	Sowing	Thinning	Hoeing and earthing	Weeding
Rice	2.94 (1.02)*	69.81 (24.26)	—	—	113.83 (39.56)
Pigeonpea and rice intercrop	2.94 (0.83)	61.97 (17.50)	3.14 (0.89)	9.80 (2.77)	146.01 (41.24)
Pigeonpea	2.94 (1.52)	46.28 (23.95)	3.14 (1.63)	9.80 (5.07)	72.22 (37.38)

Cropping system	Spraying	Harvesting	Total	Cost of E.I. (\$)	Cost/MJ $\times 10$ (\$)
Rice	7.84 (2.73)	93.32 (32.43)	287.74 (100.0)	122.58	426.00
Pigeonpea and rice intercrop	11.76 (3.32)	118.42 (33.45)	354.04 (100.0)	151.42	427.69
Pigeonpea	11.76 (6.09)	47.06 (24.36)	193.20 (100.0)	82.83	428.73

\* Figures in parentheses indicate percentage.

**Table 1e** Energy Input (MJ/ha) through Tractor and Tractor-drawn Implements

Cropping system	Tractor	Implements	Fuel	Total	Cost of EI (\$/ha)	Cost (\$/MJ $\times 10^3$ )
Rice	148	77	2703	2928	48.08	16.42
Pigeonpea and rice intercrop	148	77	2703	2928	48.08	16.42
Pigeonpea	148	77	2703	2928	48.08	16.42

**Table 1f** Cost (\$) per 1000 MJ of E.I. from Different Sources

Cropping system	Seeds	FYM	Pesticides	Tractor and implements	Hand tools	Labour
Rice	17.01	15.34	97.47	16.42	32.16	426.00
Pigeonpea and rice intercrop	22.97	15.34	70.45	16.42	48.89	427.69
Pigeonpea	45.35	24.97	70.45	16.42	55.07	428.73

**Table 2** Yield and Energy Output (MJ × 10<sup>3</sup>/ha) from Different Cropping Systems

Cropping system	Yield of rice (t/ha)		Yield of pigeonpea (t/ha)		Energy output (EO)		Total	Energy input (EI)	EO/EI	Cost of EI/MJ × 10 (S)	Cost of total EI (S)	Cost of total EO (S)	Benefit cost ratio
	Grain	Straw	Grain	Stick	Rice	Pigeon-pea							
Rice	1.99	3.24	—	—	69.76	—	69.76	8.725	8.00	30.96	270.25	331.67	1.23
Pigeonpea and rice intercrop	1.15	1.76	1.08	4.39	39.03	94.88	133.91	9.163	14.61	36.39	333.33	638.42	1.91
Pigeonpea	—	—	1.29	4.86	—	106.51	106.51	5.823	18.29	39.15	227.83	578.00	2.54

Pigeonpea required about 80.50% of EI for these inputs. EI through seeds was the lowest for pigeonpea ( $0.294 \times 10^3$  MJ per ha) and the highest for rice ( $1.47 \times 10^3$  MJ/ha). The percentage of EI on labour was identical for all the systems. It was higher (10.70%) for pigeonpea in terms of pesticides and least for rice (2.00%). The variation in EI through hand tools (Table 1b) ranges from 0.038 to  $0.083 \times 10^3$  MJ/ha, the highest being for rice and the lowest for pigeonpea. More than 60.00% of EI through hand tools was spent in threshing and winnowing operations for rice and intercrops against 34.60% in case of pigeonpea. But the percentage of EI on hand tools remained below one in all the cases with respect to total EI (Table 1a).

It is shown in the data on EI for different events on hand- and manually-operated tools (Table 1c) that the highest percentage of energy ranging from 33 to 63% was consumed for harvesting operation followed by sowing (18 to 31%). The least amount of energy was consumed in weeding operation (1 to 2%). The cost per 1000 MJ EI was lowest for rice being \$32 and highest for intercrops and pure pigeonpea varying from \$49 to \$55.

More energy was spent on labour (Table 1d) for weeding operation (37 to 41%) followed by harvesting (24 to 34%). These two operations consumed about 62 to 75% of the total energy generated from human labour. Rice and pigeonpea intercropping system required 19% and 45% more labour energy input than rice alone or pigeonpea alone, respectively, reflecting the labour intensiveness

of the intercropping over monocropping. The cost per 1000 MJ from labour source was more or less similar for all the system.

The cost of obtaining 1000 MJ of energy (Table 1f) through tractor with implements was the lowest (\$16.42) followed by hand tools (\$32 to \$55) and labour (\$426 to \$429). This suggests the use of small scale or partial mechanization of agriculture in developing countries with more efficient labour-saving hand tools.

The maximum EI of  $3.107 \times 10^3$  MJ/ha (39%) was used by fertilisers and manure followed by tractor and accessories ( $2.928 \times 10^3$  MJ/ha). These two sources accounted for about 76% of the total EI.

#### Energy Output (EO)

More energy was spent in pigeonpea and rice intercropping system ( $133.91 \times 10^3$  MJ/ha) which was 48% and 20.5% more than rice or pigeonpea alone, respectively. This is in conformity with the findings of Pal et al (1985) and Mahapatra et al (1987). It was observed that it is possible to harvest about  $64.15 \times 10^3$  MJ/ha more energy from intercropping systems by spending only 5.00% extra energy over rice crop alone. Pigeonpea could give  $36.75 \times 10^3$  MJ/ha against a reduction of EI about 23.00% as compared to rice alone. This clearly shows that growing of rice is not an efficient system in the rainfed uplands than pigeonpea or pigeonpea and rice intercropping system.

The highest amount of \$333.33 was spent on EI with the highest outturn of \$638.42 through EO for pigeonpea and rice intercropping system. The cost per 1000 MJ

of EI was highest for pigeonpea (\$39.12) followed by pigeonpea and rice (\$36.39/MJ × 10<sup>3</sup>). But the cost benefit ratio and EO/EI were greater for pigeonpea than the other systems. Energy input-output ratio increased considerably for pigeonpea alone or in combination with rice (14.76%) which is in agreement with the suggestions made by Loftness (1987).

#### Conclusion

The study conducted over the period of two years in dryland lateritic soil of Orissa reveals that, on an average,  $3.107 \times 10^3$  MJ of energy per ha was utilised through fertiliser and manure followed by tractor and tractor-drawn implements ( $2.928 \times 10^3$  MJ/ha). These can be reduced by developing efficient bullock-drawn implements and the use of larger quantities of organic manure over inorganic fertilizer. The cost of energy for labour was highest (\$428.00/MJ × 10<sup>3</sup>) followed by hand tools (\$44.00/MJ × 10<sup>3</sup>) which can be minimised by developing efficient labour-saving tools. The substitution of rice by pigeonpea alone or by an intercrop of pigeonpea and rice has caused the ratio of energy output to energy input to increase from 8 to 18 indicating better energy efficiency. It is, therefore, suggested that in order to reduce the pressure on scarce fossil fuels, small scale mechanization through efficient bullock-drawn implements and hand tools be used as these require less investment than large scale mechanization for the poor resource-based farming community of the rainfed region of the developing countries.

(Continued on page 58)

# Rice Post-harvest Practices and Loss Estimates in Bangladesh: Threshing through Sundrying



by  
A.K.M. Anwarul Haque  
Scientific Officer  
Rice Technology Div.  
B.R.R.I., Gazipur 1701  
Bangladesh

N.H. Choudhury  
Chief Scientific Officer and Head  
Rice Technology Div.  
B.R.R.I., Gazipur 1701  
Bangladesh



M.A. Quasem  
Senior Scientific Officer  
Agric. Engg. Div.  
B.R.R.I., Gazipur 1701  
Bangladesh

Jose R. Arboleda  
Project Manager  
FAO/BIRRI Project  
AG: GCPP/BGD/017/NET  
Bangladesh

## Abstract

The objective of the study was to observe rice post-harvest practices and estimate losses occurring in the country from threshing to sundrying operations. The post-harvest practices studied were threshing by hand beating, ox-treading, use of pedal threshers, hand beating followed by ox-treading; cleaning of threshed paddy by winnowing basket 'Kula' and sundrying of unparboiled paddy on packed ground, bamboo mat, at courtyard and on road side.

The total loss estimates from threshing through sundrying varied between 3.1 to 4.0% in three seasons studied with a weighted average of 3.5%. This was equivalent to 0.7 million t actual paddy loss. The 'Aus' season observed highest loss while 'Boro' season had

the least. Loss in threshing and winnowing operation did not exceed 1.0% except in hand beating with 1.6% weighted loss. Threshing by hand beating followed by ox-treading and pedal thresher experienced similar loss but the former method was more time consuming. Drying loss estimate was high (2.2%), which was probably due to encroaching and eating by domestic animals and birds and small quantity of paddy dried by the farmers.

## Introduction

Bangladesh is an agricultural country with rice as the staple food. She has 11.5 million ha cultivable land of which 89% land area is used for rice cultivation producing more than 20 million t of paddy (BBS, 1984). Rice in Bangladesh is grown and harvested during 'Boro', April to June; 'Aus', July to August; and 'Aman' November to December; seasons. 'Aman' and early 'Boro' crops are harvested in dry lands while late 'Boro' and

'Aus' crops are harvested in wet and flooded fields. Yields of 'Boro', 'Aus', and 'Aman' paddy are 4.7, 4.8 and 10.6 million t per season, respectively. High yielding varieties (HYVs) cover 25% of the total rice growing area producing 40% of the total production (BBS, 1984). The values include pajam.

Karim and Rashid (1979) reported that 96% of the farmers in Mymensingh district suffered rice post-harvest losses during 'Boro' season. In another report they mentioned that about 3.0% paddy were lost during cutting and threshing in 1981 'Aus' season (Karim et al, 1982). Greeley (1981) conducted a study in Bangladesh and found that total physical losses in harvesting to drying operations did not exceed 7.0%. Bala (1978) reported that total losses in drying operation ranges from 1.56 to 5.0% in Bangladesh while the estimated post-harvest losses in drying ranges from 1.0 to 5.0% for Southeast Asia (de Padua, 1978). Gaiser (1981) mentioned that the average post-harvest losses in paddy drying was 2.0%.

**Acknowledgement:** The authors wish to express their deep appreciation to the Director-General of the Bangladesh Rice Research Institute for providing the necessary facilities and to the Food and Agriculture Organization for financial support. Laboratory and field assistance is also gratefully acknowledged.

The present study was conducted in Bangladesh to observe and gather information on existing post-harvest operations (threshing, cleaning and drying) at village level and to estimate the size and causes of losses occurring in the country and to suggest methods of reducing these losses.

### Post-Harvest Practices

The post-harvest operations commonly practiced by the farmers at the village level in Bangladesh is shown in Fig. 1. It can be noted that paddy from the field undergoes a series of operations before it is sold, consumed or used as seeds.

#### Threshing

Threshing is the removal or separation of grains from the panicles of the paddy stalks. Hand-beating; ox-treading; combination of both; and use of pedal threshers are the most common methods of threshing. Foot treading is sometimes practiced in some areas.

In hand-beating, small bundles are beaten on drum and wooden logs. Sometimes stones, bench, "chowki," table, bare ground and other hard materials are also used. Depending upon bundle size, variety, and worker each bundle is beaten 5 to 10 times in order to shatter all grains.

In ox-treading, bundles are initially placed around, with panicles positioning inward or on one side of the threshing floor, with a thin layer of harvested stalks is spread for threshing by the animals. Two to four oxen are generally used in single row tandem going around the materials being threshed. A man always stays behind to drive the oxen, tied loosely on a pole at the centre, to walk around the threshing floor. In some areas, no centre pole is placed. The man behind controls the movement of the oxen with a tether on the

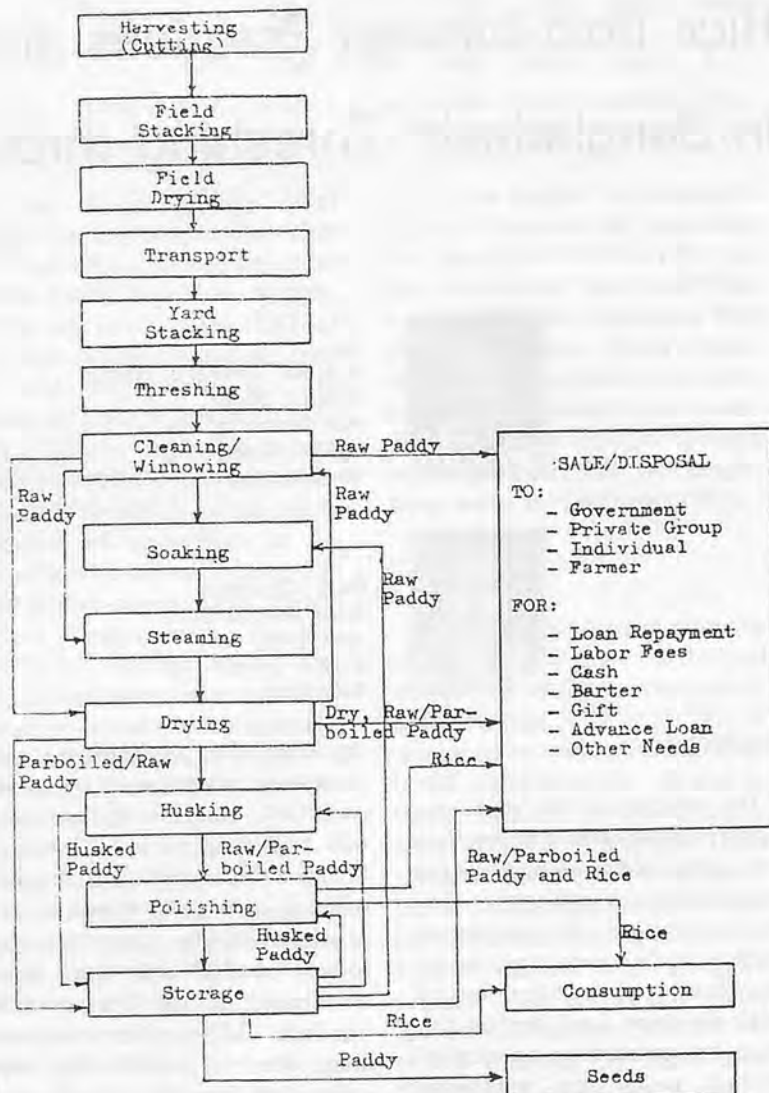

Fig. 1 Post-harvest operations at the farm and village level in Bangladesh (Arboleda 1982).



Fig. 2 Hand threshing.



Fig. 3 Ox-treading.

animal nearest to the centre. Well-off farmers sometimes use 6 or 8 oxen in double row tandem to thresh more materials at a time. The diameter of the threshing circle varies from 4 to 10 m de-

pending upon the volume of stalks, number of oxen, and space available. As ox-treading continues, additional bundles are spread by one or two men who also take care of turning and shaking the straw

from time to time. This continues until all the grains are separated from the straw. Grains are then partially cleaned and removed from the threshing floor. The same procedure is followed in the succeeding threshing batches.

In most parts of the country, ox-treading is done as a second stage threshing after hand-beating to separate further the remaining filled grain and to soften the straw used for animal feeds. The time gap between the two stages of threshing operations varies up to 3 months depending upon the climate, availability of animals, labour, farmers priority, and other factors. In the 'Aman' season, it usually extends up to 3 months because the weather is cool and dry, no rain, and the paddy and straws are already dried. In 'Boro' and 'Aus' seasons, however, priority is given by the farmers to their field activities than rethreshing. Sometimes, the second stage threshing (ox-treading) is not done because the delay has already deteriorated the straw.

In Sylhet, hand-beating and foot-threshing are practiced occasionally when the straw are needed for roofing; small quantity to be threshed; yard is wet; animals are not available; no facilities for ox-treading and there is an urgent need for food.

Pedal thresher is the only mechanical equipment used for threshing paddy specially, high yielding varieties. It is a portable machine consisting of a strong wire looped cylinder, driven by foot through a shaft, lever and gear systems. The machine is operated by moving the pedal up and down with one foot while harvested stalks are fed on the rotating cylinder. Grains are separated from the panicles with the action of protruding wire loops in the rotating cylinder. Generally, one helper picks a handful of harvested stalks from the pile, gives it to the oper-

ator, thresh while pedaling, pick another batch, thresh and so on. Sometimes, it is efficiently used by four persons, including two assistants, may be women and children, work on each side of the thresher. It is also used efficiently during night time and in indoors, particularly during rainy season.

The pedal thresher is closely associated with threshing HYVs. In the Comilla district where HYVs are widely grown, almost all farmers use pedal threshers. With the skill developed in operating pedal threshers, attempts are being made to use pedal threshers in threshing local rice varieties (LVs). A small percentage of the LVs are threshed using pedal threshers in Comilla. It has an added advantage of being operated by women and children anytime and used indoors, particularly during the rainy season. With the efforts made by the government and manufacturers in disseminating informations for wide sales, the use of pedal thresher is gaining popularity in other parts of the country, particularly in places where HYVs are grown. Pedal threshers were already observed being used by the farmers in the northwest region (Bogra, Dinajpur, Rangpur, Rajshahi), particularly in the 'Boro' and 'Aus' seasons when HYVs are widely grown. Traditional threshing is still widely practiced during the 'Aman' season.

#### Cleaning

Cleaning is done to separate foreign materials like leaves, straw, empty grains, etc. from threshed grains. This is done by using 'kula', an oval-shaped bamboo woven winnowing basket with elevated sides to hold the grain except at one end where materials are discharged during its use. Grains are placed in the 'kula' raised above or about head level and gradually poured for wind (breeze) to blow and to separate light impurities from good



Fig. 4 Cleaning by winnowing basket.

grains. When the air is calm, the 'Kula' is used for fanning the grains to separate light impurities. Sometimes, sieves are used to separate bigger and heavier materials. Cleaning is done immediately after threshing, particularly during 'Aman' season when the grains are already dry. When the threshed grains are wet, preliminary drying is done before cleaning. Sometimes cleaning is done before and after drying the grain.

#### Drying

Drying is a thermodynamic process wherein moisture is removed from the material by vapour pressure differences between grain and the ambient air. It is also accomplished with evaporative cooling action.

Sundrying is the most common method practiced all over the country for drying paddy. Home yard is generally used for this purpose. Sometimes roadsides are used, particularly during wet season. Dry courtyard and fields are also used during 'Aman' season. Wet paddy are spread over mud plastered dry 'Kacha' floor with an irregular thickness of 5 to 10 mm. Grains are usually stirred by foot dragging or by wooden spreader. During 'Boro' and 'Aus' harvest seasons, when drying floor remains wet and damp, woven bamboo mat, plastered with cowdung and mud is used. Women in the farm family usually determine the moisture content of dried grain by biting. This practice is reasonably good when based on long years of experiences.

The farmers of Sylhet region

where the rainfall is generally high, usually sundry paddy on woven bamboo mats in all the seasons. This practice was developed probably for easy retrieval and to separate paddy from the ground. In the wet season, farmers in the Bogra region sometimes dry paddy in ceiling floor of the tin shed bungalow type mud walled house called 'Tala'. The grain is protected from rain and continues to dry by heat radiation under the normal roof of the house. The required drying time, however, is longer compared to sundrying.

### Loss Assessment Procedure

A total of 35 villages from five areas were selected for the loss assessment study conducted during 1983 'Aman', and 1984 'Boro' and 'Aus' harvest seasons. The selection was based on accessibility, co-operation of the farmers and representativeness of the village in the cropping pattern and post-harvest practices in the district. Six replications were made for each operation studied in each village. During threshing and cleaning, losses were calculated by dividing the lost grain collected, by the paddy yield obtained after threshing harvested stalks from bundles or area studied. Drying losses were calculated by dividing the difference between initial and final weights by the initial weight of the grain.

All grain weights were converted to standard 14% moisture content (wet basis) before loss calculations of field and laboratory data were made. Detailed methods and procedures contained in the post-harvest rice loss assessment manual, prepared previously for the study by Arboleda et al. (1983) was used. The summary of the methods used in different operations studied are stated below.

### Threshing

Loss assessment in threshing was done on a measured 50 m<sup>2</sup> (5 x 10) area which was harvested by using sickle, bundled, transported and threshed to get the grain weight as obtained yield. Yards were cleaned before threshing harvested stalks. Threshing loss was expressed as separation (unthreshed and un-separated grains that remained with straw) and scattering (uncollected scattered grain on threshing area) loss.

### Cleaning

Paddy cleaning, commonly done by using 'Kula' either by wind breeze or fanning, was studied. Un-separated filled grains mixed with chaffs and straws, and remaining grains scattered in the cleaning area were collected as cleaning loss.

### Sundrying

Grains were weighed and moisture contents were determined during the start of drying. Grains were then spread on farm yard or roadside under the sun by the farmers. Stirring was done by them whenever they felt its necessity. At

the end of drying, grains were accumulated and allowed to cool their surfaces for 1 hour. Weight and moisture content were then taken and drying loss was calculated. Loss components contains domestic animal and birds eating, spillage, scattering, etc.

## Results and Discussion

### Effect of Methods on Loss

Scattering loss during threshing operation was negligible (below 0.25%) in all seasons and methods studied. Separation loss, however, significantly varied with the methods. Hand-beating yielded higher loss in 'Aman' (2.13%), 'Boro' (2.88%) and 'Aus' (0.99%) seasons compared to other methods (Table 1). This could be due to traditional practice of rethreshing the straw by ox-treading. Farmers were not very anxious to recover completely the unthreshed and un-separated grains from straw because of the reliance to ox-treading which could reduce the loss by about 1.0%. Also, ox-treading softens the straw for use as animal feeds. In

**Table 1.** Percent Loss Estimates in Threshing to Sundrying Operations by Method and Season<sup>1)</sup>

Post harvest operation	Method	'Aman'	'Boro'	'Aus'	Weighted Average
Threshing scattering	Hand beating	—	0.02 (5)	—	0.02
	ox-treading	0.09 (25)	0.25 (2)	0.01 (1)	0.10
	Hand beating + ox-treading	0.15 (22)	0.07 (25)	0.10 (23)**	0.10
	Pedal threshing	0.04 (8)	0.01 (14)	0.01 (21)	0.02
	Weighted average	0.11	0.05	0.06	0.07
Threshing separation	Hand beating	2.13 (3)**	2.88 (5)**	0.99 (14)**	1.57
	Ox-treading	1.01 (51)	0.61 (27)	0.95 (25)	0.89
	Hand beating + ox-treading	0.55 (27)	0.39 (27)	0.69 (28)	0.54
	Pedal threshing	0.65 (11)	0.76 (27)	0.43 (21)	0.62
	Weighted average	0.87	0.72	0.75	0.78
Cleaning/winning	Winnowing basket 'Kula'	0.46 (88)	0.57 (91)	0.36 (88)	0.46
Raw paddy drying	Roadside	—	2.11 (12)	3.10 (6)	2.44
	Homeyard	2.14 (74)	1.71 (78)	2.82 (69)	2.20
	Weighted average	2.14	1.76	2.84	2.22
Total (sum of average)		3.58	3.10	4.01	3.53

1) Number in parentheses are sample sizes.



Malaysia, reported loss in threshing was 2.15% (Mohamed, 1981) but only 1.0% in Korea (Lee, 1984). It is interesting to note, however, that the estimated loss in threshing by pedal thresher was comparable to hand-beating followed by ox-treading with almost negligible scattering loss. In general, loss estimates obtained in different threshing methods (except hand-beating) were low in the three seasons studied.

Loss observed in cleaning/winnowing operation was much less and did not vary very much for any of the seasons (Table 1).

Sundrying effectively depends upon the availability of sunshine. With the country's latitude at about 24°C, Manalo (1975) reported that the expected day length is about 12.7 to 13.7 h per day during the months of April to August ('Boro' and 'Aus' harvest) and 11.0 and 10.7 h for the months of November and December ('Aman' harvest). However, he reported further that the probable bright sunshine hours per day were about 8.4, 8.7, 5.0, 5.4 and 5.6 for the months of April, May, June, July and August, respectively, and 9.2 and 9.1 h during November and December.

Drying losses were observed to be higher in 'Aus' and 'Aman' seasons compared to 'Boro' (1.76%) season with the weighted average of (2.2%) (Table 1). It was observed that the probable causes of loss were eating by domestic animal (chickens, ducks, goats and cows) and birds; grain spillage and scattering during drying. Mannan (1983) reported that a common myna (*Acridotheres tristis* Linn), abundant in the country consumes about 10.9 g and a black rock pigeon (*Columba livia* Gmelin) consumes 51.4 g of paddy per day. Dry matter loss could be another reason for loss during drying. Other reasons for the high loss observed during drying were the

Table 2 Percent Loss Estimates in Threshing to Sundrying Operations by Farm Size and Season<sup>1)</sup>

Post-harvest operations	Farm size	'Aman'	'Boro'	'Aus'
Threshing scattering	Small	0.10 (25)	0.06 (23)	0.06 (22)
	Large	0.11 (30)	0.05 (21)	0.07 (23)
Threshing separation	Small	0.98 (45)	0.68 (46)	0.63 (43)
	Large	0.76 (47)	0.76 (41)	0.86 (45)
Cleaning/winnowing	Small	0.41 (44)	0.63 (46)	0.40 (45)
	Large	0.51 (44)	0.51 (45)	0.33 (43)
Sundrying	Small	2.42 (36)	1.67 (46)	2.79 (38)
	Large	1.83 (39)	1.58 (44)	2.71 (37)

1) Numbers in parentheses are sample sizes.

small quantity of paddy dried by the farmers because 1 kg grain lost in drying 25 kg paddy is 4% loss but is only 1% for 100 kg paddy being dried.

Farmers usually dry paddy on roadside when drying floor remains wet and damp. Roadside drying loss was observed higher than homeyard drying (Table 1). Vehicle tyres pick up some grains while passing over the grains spread for drying on the road which might probably be the reason for getting higher loss in roadside drying.

#### Large and Small Farmers

Separating the loss data between large and small farmers in the different villages studied, the results obtained did not vary very much in any of the post-harvest operations studied for any season only except in 'Aman' season drying where small farmers suffered more loss (Table 2). Statistical t-test showed that the loss difference between small and large farmers in the threshing, cleaning and sundrying operations studied was insignificant. This result implies that large farmers, locally identified by the villagers, practiced with the same care as small farmers in handling their crops from threshing to sundrying operations in all the seasons studied.

#### Conclusions and Recommendation

Total loss estimates in threshing, cleaning and sundrying operations were 3.58%, 3.10% and 4.01% for 'Aman', 'Boro', and 'Aus' seasons, respectively, with a weighted average of 3.5%. In terms of actual grain loss, this was equivalent to 0.7 million t of paddy for three seasons, calculated from the estimated production of 20.1 million t.

Low loss estimates (less than 0.6%) in threshing by pedal thresher was comparable to hand-beating followed by ox-treading. Hand-beating incurred more than 1.5% loss. Although loss variations were observed in other post-harvest operations, the loss estimates were less than 1% indicating the general awareness of farmers in minimizing loss during threshing and cleaning operations studied was insignificant. This result implies that large domestic animal and birds encroaching and eating and small quantity of paddy dried by the farmers.

It is recommended that increased food availability in the post-harvest sector can be achieved if the government could provide the necessary inputs, training and incentives for the farmers to plant HYVs because it will not only increase yield but also reduce post-harvest loss. The manufacture and use of pedal threshers must be encouraged through financial support and information dissemination because this will not only maintain low threshing loss but also provide

employment opportunities. Women and children could operate the pedal thresher while men could devote their time working in the field, particularly when hired labour is scarce. It could also be used efficiently during night time and indoors, particularly during rainy season.

#### REFERENCES

- Arboleda, J.R., R.A. Boxall and N.H. Choudhury. 1983. Post-harvest rice loss assessment manual. FAO/BIRRI Project, Field document 1.
- Bala, B.K. 1978. Post-harvest losses of paddy in Bangladesh. AMA Vol. IX. No. 4. Autumn: 54-56. Bangladesh Bureau of Statistics. 1984. 1983-1984 Statistical Year Book of Bangladesh. Dhaka, Bangladesh, 847p.
- De Padua, D.B. 1978. Post-harvest food losses in developing countries; National Academy of Sciences, Washington D.C., USA: 38.
- Gaiser, D (Summarized by Soemangat). 1981. A brief summary of paddy loss in Indonesian rice post-harvest systems. Proc. grain post-harvest tech. workshop, SEARCA, College, Philippines: 133-138.
- Greeley, M. 1981. Farm level rice processing in Bangladesh: food losses, technical changes and the implications for future research. Proc. grain post-harvest tech. workshop, SEARCA, College, Laguna, Philippines: 33-48.
- Karim, A.M.A. and M.H. Rashid. 1979. Extent of loss of Boro paddy during post-harvest operation. BAU, Mymensingh, Bangladesh.
- Karim, A.M.A., E.G. Hurley and M.N. Rahman. 1982. Assessment of quantitative loss of Aus paddy during post-harvest operations in wet season. BAU, Mymensingh, Bangladesh.
- Lee, N.W. 1984. Korean experience in post-harvest technology (Paddy). Proc. rice post-harvest tech. workshop. RAS/81/046, Cabanatuan and Santiago, Philippines: 259-262.
- Manalo, E.B. 1975. Agro-climatic survey of Bangladesh. BIRRI-IRRI, Joydebpur, Bangladesh, 361p.
- Mannan, A. 1983. Birds pests of Agriculture in Bangladesh. M.S. Thesis, Dept. of Zoology, University of Dhaka, Bangladesh.
- Mohamed, N.H. 1981. Rice grain losses from KADA area (Malaysia): An overview vis-a-vis traditional storage systems. Proc. grain post-harvest tech. workshop. SEARCA, College, Laguna, Philippines: 115-132. ■■

(Continued from page 52)

### Energy Studies in Cropping System in Lateritic Soil of Arissa, India

#### REFERENCES

- Iserman K., 1983. The extent to which agriculture is involved in environmental problems in modern industrial society. Fert and Agric 85:3.25.
- Lenka.D, 1974. Water requirements of crops in Orissa. Orissa University of Agriculture and Technology, Bhubaneswar, India, pp.1-4.
- Loftness,R.L., 1978. Energy input and agricultural productivity. In Energy Handbook. Van Nostrand Reinhold Co. New York, Litton Educational Publishing Inc. pp 13-26.
- Mahapatra P.K., Bhol B.B. and Patnaik R.N., 1987. Rice-based crop rotations for upland fields. IRRN 12(4):64.
- Mitta V.K., Mittal J.P. and Dhanwan K.C., 1985. Research digest on energy requirements in agriculture sector (1971-82) ICAR/AICRP on ERAS/College of Agril. Engg. PAU, Ludhiana PP 159-163.
- Pal M, Singh K.A., Saxena J.P. and Singh H.K., 1985. Energetics of cropping systems. Indian J. Agron. 30 (2) : i-1xi
- Rao, A.R., Gupta R.S.R. and Sharma A.P. 1987. Fuel and agricultural energy balance in Haryana, India. AMA 18 (4): 69-70.
- Senapati P.C., Mohapatra P.K. and Satpathy D., 1988. Field performance of seeding devices in rainfed situation in Orissa, India. AMA 19 (1) : 35-38. ■■

# Energetics of Forage Chopping

by  
Yumnam Jekendra  
Asst. Prof.  
Dept. of Agric. Engg.  
Manipur Agric. College  
Iroishemba, Imphal 795001, India



Pratap Singh  
Prof.  
Dept. of Farm Machinery and Power  
College of Technology and Agric. Engg.  
Udaipur, India

## Abstract

The measured total energy consumption for forage chopping follows no strictly generalised law. The energy requirement of various fodder harvesting machines differ significantly from those of net cutting. Crop acceleration, compaction and conveyance normally consume more than 50% of total energy while energy consumed in shearing stems is normally less than 3%. A desirable blade bevel angle ranging from 20° to 30° with a rake angle of 10° to 20° operating at speeds between 25 to 35 m/s gives an optimum cutting energy requirement for forage materials having 35% moisture content. Proper correlation of cutterhead parameters and forage material properties with strong support of cutting mechanics will lead to a better understanding of forage chopping energetics.

## Introduction

Studies on forage harvesters are mainly confined to time, output and performance efficiencies. The actual cutting energy requirement of forage crops, although so important, has been neglected in most studies. Without knowing the optimum cutting energy re-

quirement of forage crops, it is hardly possible to design an efficient forage harvesting machine.

In general, the energy consumed in shearing stems is normally less than 3% of total energy whereas chopping process utilises about 35% and crop acceleration and conveyance normally consume more than 50%. Thus, energy consumption can be greatly reduced if crop acceleration and conveyance energy requirements can be reduced. The cutting energy requirement of forage crops is mainly affected by two factors, namely; physical and mechanical properties of plant stem and the cutterhead parameters. There is a significant difference in relation to blade bevel angles, cutting speed and stalk diameter. At low cutting speeds, cutting energy is a linear function of stalk diameter. However, the effect of moisture content has very little effect on shear energy for sharp blades. To minimise the cutting energy requirement, a detailed study of cutting mechanics is essential. Various works done by different research workers are reviewed and attempts are made to correlate the research findings for a better understanding of energetics of forage chopping.

## Kinematics of Blade During Cutting

The kinematic relations obtained during cutting by the interaction of blade and plant stem is illustrated in Fig. 1.

A given point on the cutting edge of blade rotates around point 'O' with a velocity 'V' which has tangential and radial components as 'V<sub>t</sub>' and 'V<sub>n</sub>', respectively.

The angle of slide, 'Θ' is given by:

$$\tan \Theta = V_t/V_n = \frac{c}{\sqrt{r^2 - c^2}}$$

where, tanΘ is called sliding coefficient.

The peripheral force, 'P' is given by

$$P = P_1 + P_2 \\ = N \cos \Theta + T \sin \Theta \quad \dots(1)$$

where,

N = normal force acting to the cutting edge

T = Tangential force

Also,

$$N = P \cdot l \text{ and,}$$

$$T = \mu \cdot N$$

where,

P = specific cutting resistance per cm

μ = frictional coefficient

Substituting these values in equation (1), we have peripheral force, 'P' as,

$$P = p \cdot l (\cos \Theta + \mu \sin \Theta)$$

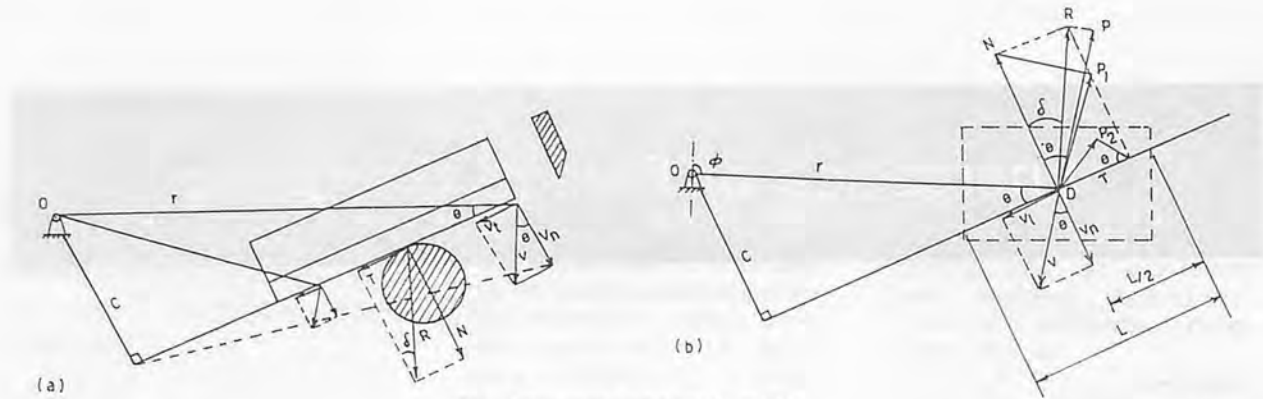

Fig. 1 Kinematic relations in cutting.

It was observed that the normal force may be reduced greatly by cutting with a large amount of sliding. The resultant force and the displacement vector do not coincide in a straight line, i.e.,  $\Theta \neq \delta$  (ref. Fig. 1 (b)). The cutting force linearly increases with the increase in edge angle.

The kinematics of single rotary blade moving in a horizontal plane are also discussed in relation to the operation parameters. With this, an optimum cutting efficiency can be derived and cutting energy requirement can also be optimised.

The tooth depth of the blade is expressed as,

$$h = \frac{V_m (2\pi - \beta)}{2\pi N}$$

where

$V_m$  = velocity of the machine  
 $\beta$  = angle between 1st and 2nd tooth when counted along positive direction of rotation

$N$  = blade speed, r.p.m.

To nullify the uncut gap area between two blades the tooth depth, 'h' should be expressed as:

$$h = l \cos \alpha$$

where,

$l$  = inclined length of the tooth  
 $\alpha$  = rake angle

For a blade peripheral velocity ' $V_b$ ' the time taken for two consecutive teeth to pass the axis is given by:

$$t = \frac{2\pi R}{n \cdot V_b} \dots (2)$$

where,

$t$  = time taken for two consecutive teeth to pass a referred

axis

$R$  = radius of blade  
 $n$  = number of teeth

Furthermore, the blade will advance a distance 'h' along the referred axis due to translatory motion in time  $t'$ ,

$$t' = \frac{h}{V_m} \dots (3)$$

To obtain at least one cut for distance 'h', the time ' $t'$ ' must be equal to ' $t$ ' and if more than one cut is desired, then,  $t < t'$

Thus combining (2) and (3) we have,

$$\frac{2\pi R}{n \cdot V_b} \leq \frac{h}{V_m}$$

$$\frac{V_m}{V_b} \leq \frac{n \cdot h}{2\pi R}$$

The ratio  $\frac{V_m}{V_b}$  is a useful parameter for ascertaining whether proper cutting is achieved. This ratio depends on blade parameters such as h, R and  $\omega$ . Thus, for a certain blade specification, the machine should not be operated below a minimum value of  $V_m/V_b$ .

### Deformation of Plant Material Caused by Cutting

The total force required to cut plant stems by unit width of blade can be divided into two stages: the initial crushing of the material before cutting and cutting of the crushed material.

The penetration of cutting knife

into the material causes deformation. The various forces acting on the surface of the knife are illustrated in Fig. 2.

The normal force acting on the inclined face of the knife is the sum of the horizontal and vertical components, i.e.,

$$N = P_v \sin \Theta + P_h \cos \Theta \dots (1)$$

While, tangential force arising on it is expressed as,

$$T_2 = \mu N = N \cdot \tan \phi$$

where,  $\mu = \tan \phi$  = friction coefficient

Tangential force on vertical side, ' $T_1$ ' is given by,

$$T_1 = \mu \cdot P_h$$

and vertical component of ' $T_2$ ' is expressed as,

$$T_2' = T_2 \cdot \cos \phi$$

Thus,

$$T_2' = N \cdot \tan \phi \cdot \cos \Theta = \mu \cdot N \cdot \cos \Theta$$

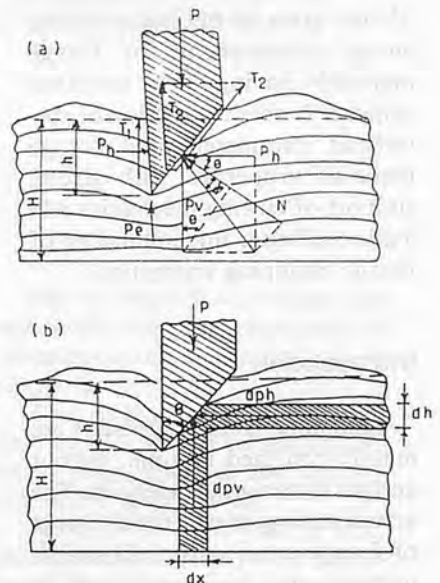

Fig. 2 Force relations for a knife penetrating into the plant material.

$$= \mu(P_v \cdot \sin\theta \cdot \cos\theta + P_h \cos^2\theta) \quad \dots(2)$$

A force 'Pe' is created at the instant of cutting on the knife edge by the material and is given by,

$$P_e = \delta \cdot l \cdot \sigma_B \quad \dots(3)$$

where,

$\delta$  = thickness of blade edge  
(50-150 $\mu$ m)

l = length

$\sigma_B$  = yield strength of the material under the edge. Vertical equilibrium of forces is expressed as,

$$P = P_e + P_v + T_1 + T_2$$

The vertical and horizontal forces 'P<sub>v</sub>' and 'P<sub>h</sub>' are determined by integrating the elemental forces 'dP<sub>v</sub>' and 'dP<sub>h</sub>' in Fig. 2 b and are given as,

$$P_v = \frac{E}{2H} \cdot h^2 \cdot \tan\theta \quad \dots(4)$$

and

$$P_h = \frac{\nu \cdot E}{2H} \cdot h^2 \quad \dots(5)$$

where,

E = mean modulus of deformation

$\nu$  = Poisson's ratio

h = preliminary compaction thickness

H = total thickness of material

Here it is assumed that Hooke's law is applicable to plant materials.

Thus, the equilibrium can be re-written for unit length as:

$$P = \delta \cdot \sigma_B + \left(\frac{E}{2H}\right) \cdot h^2 [\tan\theta + \mu \cdot \sin^2\theta + \nu(\mu + \cos^2\theta)] \quad \dots(6)$$

The first term of the equation gives useful cutting force and the second term expresses force used to overcome other sources of resistances.

The second term depends on square of 'h' lasting until the beginning of proper cutting. Its value varies linearly with layer thickness 'H'. The additional resistance increases rapidly, with increasing layer thickness and cutting efficiency is lowered.

A similar and most fundamen-

tal approach has been that of the action of blade in 2 phases: (a) the initial crushing of the material before cutting is initiated: and (b) the cutting of the compressed material. The following expression for the total force per unit width of blade, 'F<sub>T</sub>', required to compress and cut the material is reduced as:

$$F_T = \omega \cdot \sigma + E \cdot \frac{Hc^2}{2h} [\tan\alpha + \sin^2\alpha + \mu_1 (\mu + \cos^2\alpha)] \quad \dots(7)$$

where,

$\sigma$  = Compressive stress in the material during cutting

E = modulus of elasticity of the material

h = depth of the material to be cut

h<sub>c</sub> = depth to which material is compressed before cutting

$\mu$  = coefficient of friction between blade surface and material

$\mu_1$  = coefficient of internal friction of the material

$\alpha$  = blade angle

w = width of the blade edge.

The significance of the above equation goes almost parallel to that of the earlier equation.

### Mechanics of Impact Cutting

The free cutting of forage crops requires a reaction force corresponding to the maximum cutting force that arises in the material. The reaction force has the following components; (a) the mass inertia (resistance to acceleration) of the stalks being cut, and (b) static reaction forces due to bending of the stalk and angular displacement of cross-sectional area cut.

The force analysis of impact cutting is shown in Fig. 3.

The free cutting mechanism is governed by the following differential equation of motion:

$$\Delta m \cdot \left(\frac{d^2x}{dt^2}\right) = S(\delta) - P_h(x) - P'_h(x) \quad \dots(1)$$

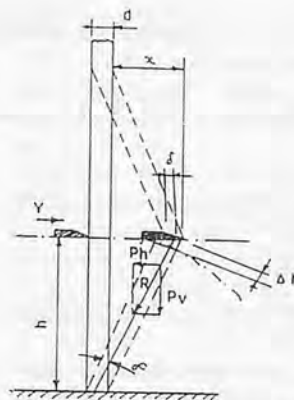

Fig. 3 Free cutting of standing forage materials.

where

$\Delta m$  = equivalent mass of accelerated parts of the stalk

$\frac{d^2x}{dt^2}$  = acceleration of the equivalent mass

S( $\delta$ ) = cutting force

P<sub>h</sub>(x) = horizontal force originating from bending of the stalk

P<sub>h</sub>' = horizontal component of tension force R originating from the motion along a circular arc.

The horizontal force due to bending is given by:

$$P_h(x) = \frac{3EI}{h^3} \cdot x \quad \dots(2)$$

where,

E = modulus of deformation of stalk under bending

I = moment of inertia of cross-sectional area

h = height of cutting

The force required for elongation of the stalk by  $\Delta h$  is given as,

$$R = A \cdot E \cdot (\Delta h/h)$$

thus its horizontal component, P<sub>h</sub>'(x) can be expressed as,

P<sub>h</sub>'(x) = [1/h - 1/√(h<sup>2</sup> + x<sup>2</sup>)] A · E · x where, A = cross sectional area of cut.

By the method of dimensional analysis, the critical velocity of the knife can be expressed as:

$$V_c = c \cdot \sqrt{d \cdot S_{max} / \Delta m}$$

where,

d = diameter of stalk, m

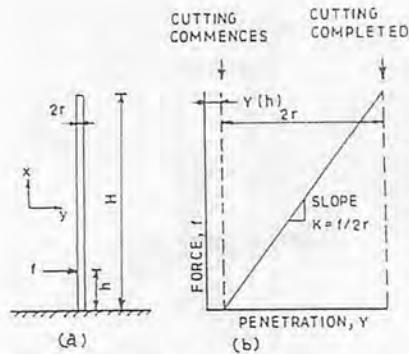

Fig. 4 a) Model of the forage system as a uniform cantilever subjected to a forcing function,  $f$ . b) Model of the forcing function,  $f$  as it penetrates and cuts the stem.

$S_{max}$  = maximum cutting force, dN

$\Delta m$  = equivalent mass, kg  
 $c$  = constant

The value of 'c' is normally accepted between 3.13 and 4.43.

The plant stem can be considered as a uniform cantilever beam (Fig. 4). During impact cutting the stress waves are distributed to the stem base before cutting which is more pronounced in bigger diameter stems. The impact cutting force is given as:

$$f = K[V \cdot t - y(h)]$$

where,

$K$  = resistance to penetration, N/m

$V$  = blade velocity, m/s

$t$  = time, s

$y(h)$  = deflection of stem at point of impact, m

### Energy Requirements for Cutting

In rotary types of blades, the effect of centrifugal force is prominent and considerable amount of power is lost as friction energy in between the chopped material and periphery of the housing. The friction energy is expressed as:

$$E_r = 4.848 \times 10^{-6} \cdot \mu \cdot \beta \cdot V^2$$

where,

$E_r$  = friction energy, kWh/Mg of material

$\mu$  = coefficient of sliding friction between the chopped material and housing

$\beta$  = angle subtended by the average arc of housing periphery rubbed by the chopped material, deg.

$V$  = peripheral speed of impeller, m/s

It is assumed that the chopped forage material leaves the impeller blades or cylinder type knives at about peripheral speed of the cutterhead with kinetic energy,  $E_k$ , which is given as:

$$E_k = 1.389 \times 10^{-4} V^2$$

where,

$E_k$  = kinetic energy in kWh/Mg

$V$  = peripheral speed of impeller, m/s

The friction energy is independent of the feed rate but increases as the square of the peripheral speed. The coefficient of sliding friction of chopper straw and legume silage at 73% moisture are reported as 0.3 and 0.68 and an average value 41.8 is considered for the product  $\mu \times \beta$ . Thus, in both friction energy and kinetic energy peripheral speed is the only factor to be taken into account.

For cutting a layer of forage material by a single knife edge inclined at an angle ' $\theta$ ' to the direction of cutting, the cutting energy ' $E_c$ ' is given by:

$$E_c = 1/2 f \cdot a_s + f \cdot a_c (1 + \mu \cdot \tan \theta)$$

where,

$f$  = cutting force per unit length  
 $a_s$  = area of cross-section over which material is compressed

$a_c$  = area of cross-section which is cut

$\mu$  = coefficient of friction between the blade surface and the material.

For knife speeds of about 30 m/s there is relatively little compression during cutting.

The specific energy requirement for cutting forage falls broadly within a range of 1 to 5.5 MJ/t of dry matter when results of num-

ber of investigations are examined.

The specific energy consumption of cutting head of a forage harvester based on dry matter content,  $E_d$  is expressed as:

$$E_d = \frac{enN}{\phi V}$$

Whereas on wet basis, the specific energy consumption is given as:

$$E_w = \frac{e}{\rho \cdot l_m} \left(1 - \frac{m_w}{100}\right)$$

where,

$e$  = shearing energy per unit area of stem cross section  
 $n$  = number of cutting blades in cutting head

rotational speed of cutting head.

$V$  = feed velocity of material to the cutting head

$\rho$  = specific weight of dry matter content of material

$l_m$  = mean chop length

$m_w$  = moisture content of material on wet basis.

The specific cutting energy of 3.6 MJ/t is average for a mean chopped length of 25 mm as per the results of various works. A true dry matter density of 1.42 g/cm<sup>3</sup> is considered as optimum.

There is a linear fall of ' $E_w$ ' over a range of ' $m_w$ ' from 0 to 100% and for material drier than 30%, the specific energy reduces.

The total cutting energy requirement is the sum of two distinguished stages of cutting process as shown in the following sketch.

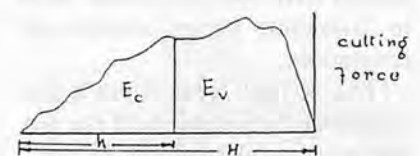

The first stage is the preliminary compaction of the material until a pressure is reached at which the material under the edge yields, and the second stage is the motion of edge in the material.

The total work is given by,

$$E = E_c + E_v$$

where,

$E_c$  = the energy required to compress upto a distance 'h'

$E_v$  = the energy required for effective cutting.

The useful cutting work efficiency, ' $\eta_v$ ' is given by

$$\eta_v = \frac{E_v}{E_c + E_v} \text{ and,}$$

specific cutting energy requirement may be expressed as,  $E_s = E/A$

where, A = cross-sectional area of cutting.

### Effect of Blade Parameters

For rotary mowers, the minimum power requirement was observed at blade bevel angles between 25° and 30°. However, experiments on counter edge cutting of rye grass, lucerne and oats suggest an optimum blade angle between 17° and 25°. Although the minimum energy requirement was obtained for 25°, little difference was observed in energy requirement over a range of 25° to 50° blade bevel angle.

The blade rake angle also affects the energy consumption in cutting. There is continuous reduction of specific energy with increasing rake angle for maize stalks. The optimum values of rake angle between 10° to 20° is recommended for minimum energy requirement.

The effect of blade velocity is mainly concerned with impact cutting. In single stem cutting the energy requirement decreases to an almost constant value at speeds of 20 m/s and above. The total energy requirement is minimum in blade speed range of 20 to 30 m/s.

### Conclusion

Various works done by many scientists on energy requirements of forage cutting are reviewed. Greater emphasis is given on theoretical force analysis as it provides more precise view in determining the energy requirement.

Different findings of the researches conducted by the scientists have been summarized with a common view to understanding better the energetics of forage chopping.

The following conclusions are drawn from the present study,

1. Optimum cutting energy requirement is obtained with blades having bevel angles ranging from 20° to 30°.
2. The most preferable blade rake angle lies between 10° to 20°.
3. One of the most important factors related to cutting energy is the blade speed. For impact cutting blade velocity of 25 to 35 m/s is considered to be the most favourable for optimum cutting energy requirement.
4. The effect of moisture content on cutting energy is distinct for dull blade edges only; otherwise its influence is not considerable.

There is insufficient knowledge about the physical and rheological properties of forage material related to cutting. There is a need for more basic information and a better understanding of cutting mechanics. Proper correlation of cutter head parameters and the forage material properties is necessary to establish the forage cutting energy requirement.

### REFERENCES

1. Banno, T. and Ogawa, T. (1979). Studies on the cutting energy of a rotary mower. *J. Society of Agril. Machinery, Japan*: 40 (4),

517-525.

2. Bledsoc, E.L. and Portfield (1971). A balanced high rotary speed sickle for cutting and trajecting blades. *Trans. ASAE*: 14 (5), 818-824.
3. Chancellor, W.J. (1958). Energy requirements for cutting forages. *Agric. Engg.*: 39 (10), 633-363.
4. D'ougherty, M.J. (1982). A review of research on forage chopping. *J. Agric. Engg. Res.*: 27, 267-289.
5. Fellar, R. (1959). Effects of knife angles and velocities on the cutting of stalks without a counter edge. *J. Agri. Engg. Res.*: 4, 277.
6. Ige, M.T. and Finner, M.F. (1976). Forage harvester knife response to cutting force. *Trans. ASAE*: 19 (3), 451.
7. Kanafojski, C. and Karwoskhi, T. (1976). *Agricultural Machines, Theory and construction. Vol.-2. Foreign Scientific Publications, Department of the National Centre for Scientific, Technical and Economic Information, Warsaw, Poland.*
8. Kepner, R.A. et al (1987). *Principles of Farm Machinery 1st Indian Edition, CBS Publishers, 485, Jain Shawan, Shahadra, New Delhi.*
9. Liljedahl, J.B. et al (1961). Measurement of shearing energy. *Agric. Engg.*: 41, 298.
10. Majumdar, M. and Datta, R.K. (1983). Kinematics of single rotary blade in rice harvesting machine. *Agric. Mech. in Asia, Africa and Latin America*: 14 (3), 49.
11. Mc. Randal and Mc. Nulty (1978). Impact cutting behaviour of forage crops (Mathematical models and laboratory tests) *J. Agric. Engg. Res.*: 23, 313-328.
12. Sitkei, G. (1986). *Mechanics of Agric. Materials. Elsevier Science Publishers. Amsterdam, The Netherlands.*
13. Tribelhorn, R.E. (1975). Chopping energy of a forage harvester. *Trans. ASAE*: 18 (3) 426, 430.

■ ■

# Mango Harvesting Techniques in Bangladesh



by  
**Daulat Hussain**  
 Assoc. Prof.  
 Dept. of Farm Power and Machinery  
 Bangladesh Agric. Univ.  
 Mymensingh, Bangladesh

**Murshed Alam**  
 Asst. Prof.  
 Dept. of Farm Power and Machinery  
 Bangladesh Agric. Univ.  
 Mymensingh, Bangladesh

**Md. Akhtar Hussain**  
 Village Gobar Para  
 P.O. Baluahat, Dist. Bogra  
 Bangladesh

## Abstract

Mango harvesting methods practised in the northern districts of Bangladesh are described in this report. The physical properties of some varieties of mango, tree characteristics, season of harvesting, and condition of mango five days after harvesting were studied. Mango growers normally use the manual harvesting techniques which are: hand picking, harvesting with "topca", and the netting method. Minimal cost of harvesting is incurred using the netting method. On the other hand, the loss incurred by using the netting method is much higher in comparison to the other methods.

## Introduction

Mango is one of the most important fruits in Bangladesh and grows well all over the country (1). Owing to certain limitations of soil and climatic condition, good quality mango is grown only in some selective areas of the country. These areas are Rajshahi, Rangpur, Pabna and Kustia (Fig. 1). The production of mango in the selective areas and total production in the country are shown in Table 1.

The total annual fruit production depends on the amount of production per tree. The overall cost of production can be lessened by increasing the productivity per

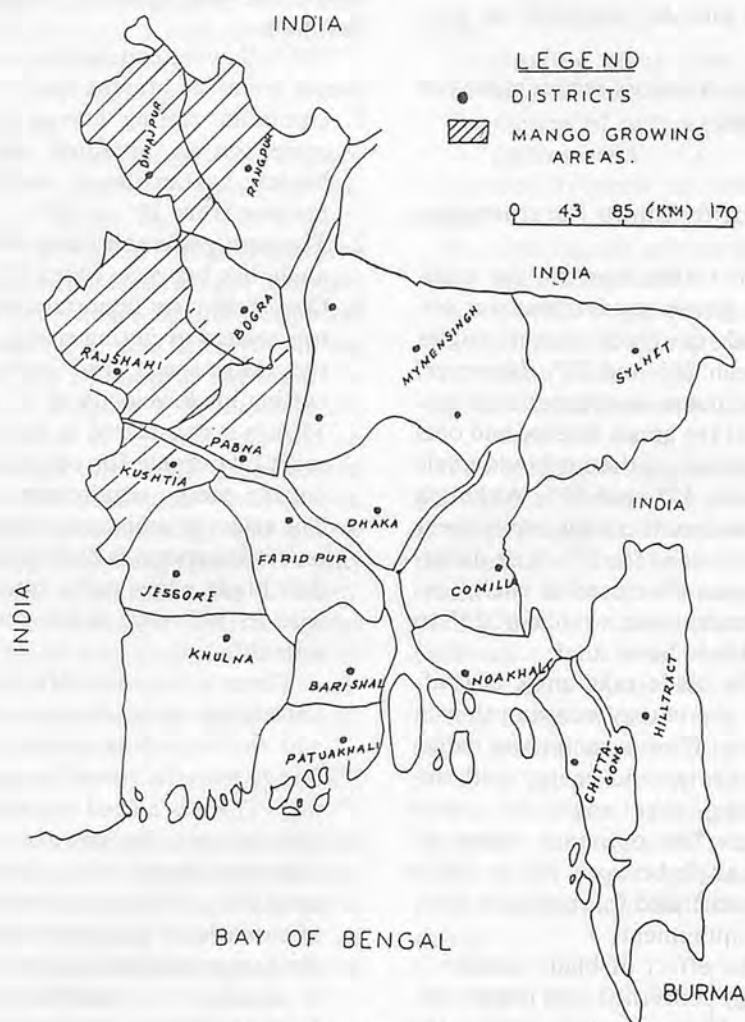

Fig. 1 Map of Bangladesh.

Table.1 Production of Mango in Bangladesh

Year	Total production area (ha)	Average yield (t/ha)	Production in selected area (t)	Percent of total production in selected areas (%)
1979-80	43280	4.704	90319	44.34
1980-81	43682	4.571	88196	44.16
1981-82	45425	3.980	65761	36.35

Source: Statistical Yearbook of Bangladesh, 1982-83, pp.265



unit area. Economic contribution increases when the number of fruit trees increases per hectre.

Mango harvesting still involves the traditional manual method which requires much labour. Harvesting is one of the most important activities in fruit production, handling and preservation cycle. Proper timing and the use of suitable method of harvesting technique are required in order to reduce bruises, punctures and tears of the harvested fruits. The requirements of a good cultivation system are: i) low production cost along with high productivity; ii) high quality fruit; and iii) maximum economic benefit to the growers.

The general objective of this study was to analyze the harvesting technique of mango in the northern districts of Bangladesh. The specific objectives were: i) to identify the methods of harvesting; ii) to study the physical properties of mango, tree characteristics, tree training and the condition of mango five days after harvesting; and iii) to study the problem associated with the present harvesting method, estimate losses during harvesting, and determine the total cost.

## Methodology

Personal interviews were carried out among the growers of mango in order to identify the different parameters regarding the status of harvesting techniques. The physical properties of some important varieties of mango and characteristics of the trees were studied through actual visit and measurements in the growing season. The cost, yield, losses, etc were determined through survey work and field experimentation. The actual condition of mango five days after harvest was determined through observation and by

**Table 2.** Physical Properties of Mango Showing Mean Values and Standard Deviation (in Parentheses)

Variety	Length (cm)	Breadth (cm)	Weight (gm)	Specific gravity
Fazli	13.78 (1.96)	9.12 (0.65)	678.4 (31.14)	1.027 ( $1.77 \times 10^{-3}$ )
Fonia	8.14 (0.88)	5.60 (0.46)	180.8 (4.6)	1.038 (0.03)
Gopalbhog	8.87 (0.55)	6.51 (0.48)	233.5 (30.9)	1.022 ( $6.73 \times 10^{-3}$ )
Himsagar	8.92 (0.71)	6.45 (2.0)	432.5 (15.0)	1.029 ( $7.98 \times 10^{-3}$ )
Kachamitha	6.67 (0.65)	4.29 (0.41)	144.3 (34.6)	1.031 ( $7 \times 10^{-3}$ )
Khisapati	8.99 (3.26)	8.43 (0.748)	245.15 (18.95)	1.019 ( $7 \times 10^{-3}$ )
Langra	9.53 (0.85)	8.48 (0.78)	280.12 (17.3)	1.023 ( $5 - 10^{-3}$ )
Koapahari	9.39 (3.13)	7.20 (2.3)	263.9 (22.1)	1.054 (0.015)
Rajbhog	10.05 (0.9)	8.44 (0.76)	265.35 (18.96)	1.030 (0.011)
Satiarkar	9.12 (0.97)	6.34 (0.85)	233.4 (16.9)	1.117 (0.026)
Ashina	11.52 (0.99)	8.61 (0.96)	342.18 (28.4)	1.05 (0.034)
Brindabani	8.73 (0.98)	6.77 (2.2)	141.8 (22.4)	1.072 (0.020)
Bhaduri	15.24 (3.5)	7.99 (2.7)	820.8 (14.93)	1.025 (0.014)

**Table 3** Characteristics of 13 Varieties of Mango Trees

Variety	Height (m)	Projected area (m <sup>2</sup> )	Tree capacity (m <sup>3</sup> )	No. of trees per ha (no.)	Number of fruits/tree
Fazli	13.5	189.78	104.90	52	1100
Fonia	12	165.45	87.06	60	1950
Gopalbhog	14	182.41	106.65	54	1900
Himsagar	13.4	178.32	100.93	56	1500
Kachamitha	10.6	220.72	88.83	45	2100
Khisapati	15.5	307.50	153.31	32	1800
Langra	11.5	367.50	167.60	27	1850
Koapahari	13.4	204.96	108.21	48	2500
Rajbhog	10.4	184.30	78.89	54	2250
Satiarkara	9.5	116.75	57.90	85	1750
Ashina	12.5	175.60	93.43	59	1800
Brindabani	13.2	215.60	109.32	46	2300
Bhaduri	11.8	195.60	94.00	51	1600

hand-picking. An ordinary meter scale was used to measure the length, breadth and weighing machine was used for measuring the weight of individual fruit. A graduated cylinder was used to determine the volume of fruit.

## Results and Discussion

### Physical Properties

The physical properties of the mango fruit refer to the length, breadth, weight and specific gravity. These properties vary from variety to variety and degree of maturity. These properties were studied for 13 important varieties of mango grown in the country's northern districts.

The physical properties of mango varied to a great extent from

one tree to another, even of the same variety, stages of maturity, etc. For easy understanding and to avoid many calculations, a sample of 20 ripe mangoes were collected randomly from a tree of each variety to determine the acceptable length, breadth and specific gravity, the statistical analyses of which are shown in **Table 2**. Physical properties are important for the design of the topca and to minimize injury to fruit during harvest and handling which directly relates to the physical properties (2,3).

### Characteristics of Mango Tree

The tree characteristics are important in developing proper technique for fruit harvesting. These characteristics are height, projecting area of a tree, capacity, struc-

ture, number of fruits per bunch and yield per tree (Table 3). The method of calculation of projected area and capacity of a tree are shown in Fig. 2.

The height of trees of the same age varied also from one orchard to another. For simplicity of estimation of height and number of fruits, five trees of the same age were selected randomly from a

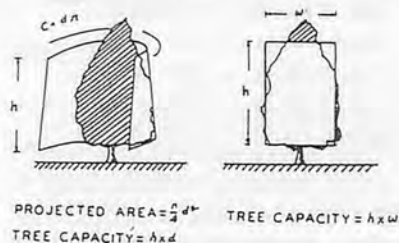

Fig. 2 Method of calculating projected area and tree capacity.



Fig. 3 Some examples of structure of tree.

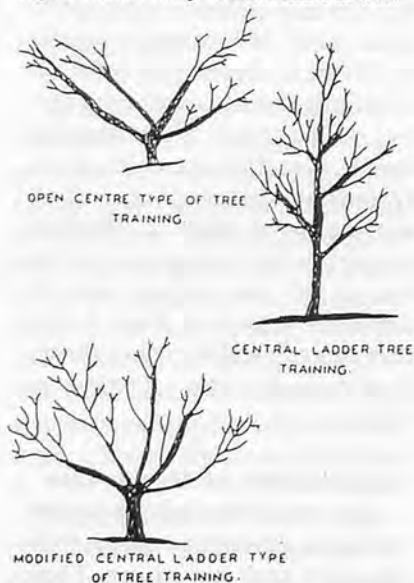

FIG. 4 EXAMPLES OF TREE TRAINING

Fig. 4 Examples of tree training.

farm. The information on age was obtained from the owner of the farm. A steel tape was used to measure the height of individual tree. The number of fruits was determined through head counting. The mean height or number of fruits are shown in Table 3. The projected area and the capacity of a tree of each variety were estimated based on Fig. 2.

### Yield

The yield of mango trees varies at different ages of a tree, the yield being highest at the age range of 35 to 45 years. After 50 years of age, the yield begins to decline due to decreasing resistance against

diseases. Also, the number of fruit bearing branches decreases when the trees are old. The yield at different ages of a tree is shown in Table 4. Soil condition, climatic condition and intensity of diseases also influence for the overall yield of mango trees. According to Jawanda (4) and Chada (5) only 0.4% fruit per bunch was obtained during harvesting time.

### Structure of Tree

The structure of a mango tree is important in harvesting the fruits as it indicates the number of branches, orientation of each branch with stem, shape, size, height, etc. Dense branches are not

Table 4 Yield of Mango in Numbers at Different Ages

	(Langra variety)					
Age	10-15	15-20	20-25	25-30	30-35	35-40
Yield	550	600	680	830	850	1020
Age	40-45	45-50	50-55	55-60	60-65	65-70
Yield	1100	1080	980	880	700	500

Table 5 Mango Harvesting Practices

Harvesting method	Position of harvesting	Tools used
Hand picking	Standing on the ground for low headed branches and climbing up trees for high headed branches.	Bag, basket, rope, leader
Harvesting by topca	Standing on the ground for medium headed branches or climbing up trees for high headed branches.	Topca, bag, ladder, rope, basket
Using netting mechanism	Standing on the ground and jerking the branches by bamboo pole and hook or climbing up trees and jerking the branches by hand.	Net, bamboo, basket

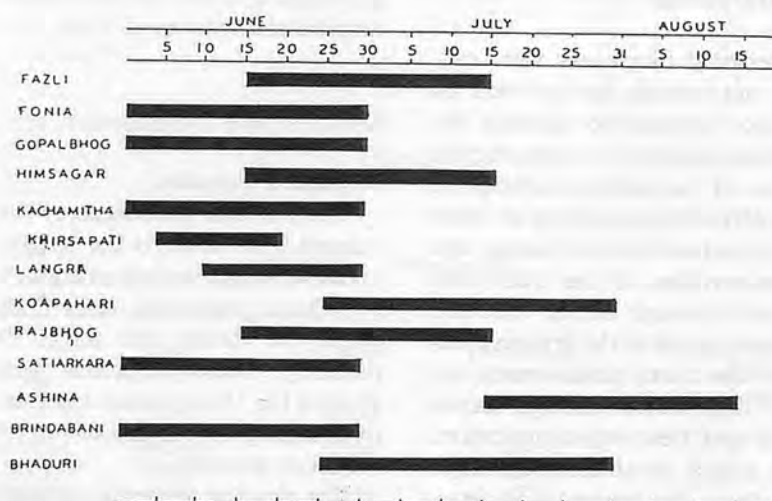

Fig. 5 Season of harvesting and availability of different varieties of mango in Bangladesh.

desirable for harvesting. Some structures of mango trees are shown in Fig. 3.

### Tree Training

Tree training means controlling the shape and size of a tree within the reach of the growers (6). This practice is important for both mechanical and manual harvesting. Mechanical harvesting of mango is rather complicated. The height and structure of a tree are important factors in tree training. The desired height and structure of a tree can be controlled (7). Many trees can be accommodated in a unit area by adopting appropriate tree training method (8,9,10). As a result, yield per unit area can be maximized. Different methods of tree training are shown in Fig. 4.

### Harvesting Practices

In Bangladesh, the mango harvest starts from May and lasts until late August (Fig. 5). The existing practices of mango harvesting techniques fall under three

major categories and are shown in Table 5.

The equipment commonly used in the existing practices of harvest-

ing is shown in Fig. 6. The topca is used extensively for harvesting mango. The mechanism of harvesting mango by topca is shown

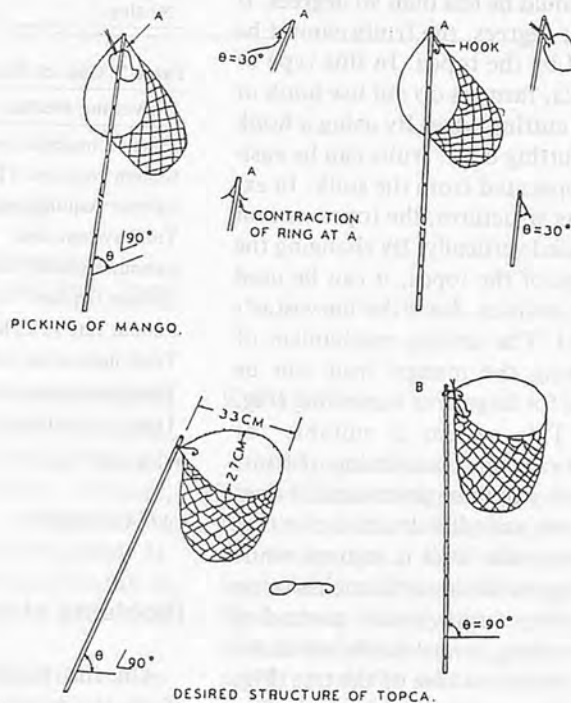

Fig. 7 Mechanism of mango picking by topca.

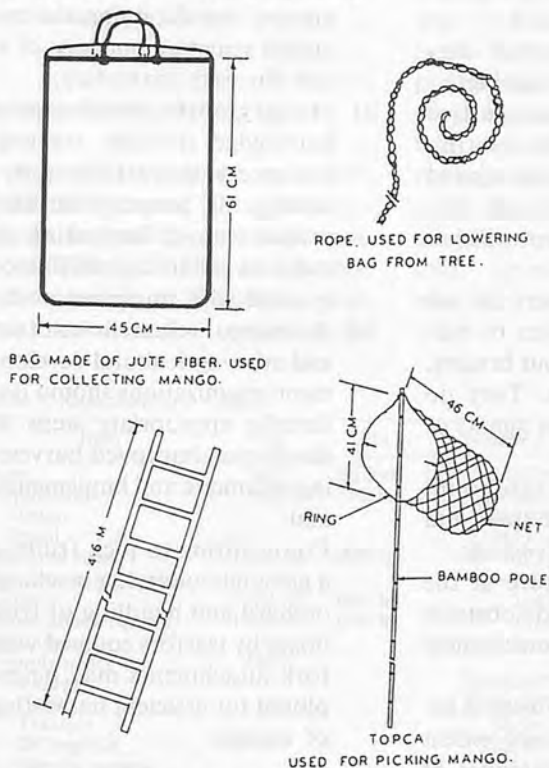

Fig. 6 Equipment used in existing practices of harvesting.

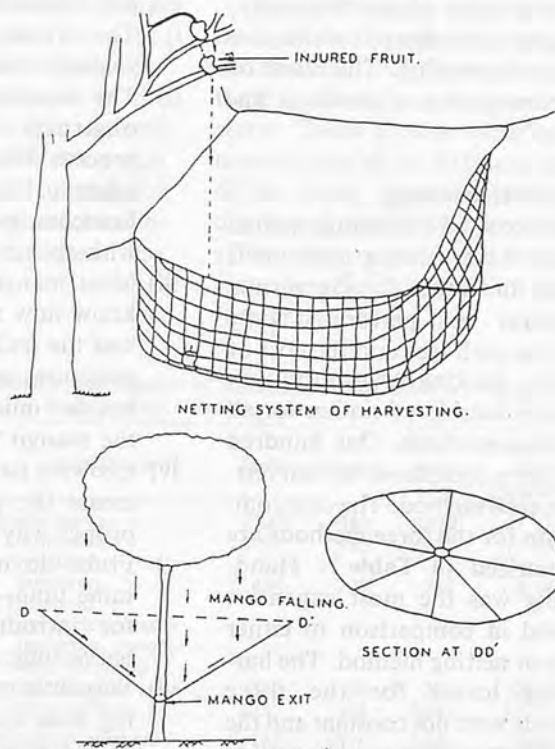

Fig. 8 Mechanism of netting system.

in Fig. 7. The fruit is separated from the stalk by a tearing action of contraction of ring at A. For the existing structure of a topca,  $\theta$  should be less than 90 degrees. If  $\theta$  90 degrees, the fruits cannot be held by the topca. In this type of topca, farmers do not use hook or any cutting edge. By using a hook or cutting edge, fruits can be easily separated from the stalk. In existing structures, the topca cannot be used vertically. By changing the shape of the topca, it can be used any position from the harvester's hand. The netting mechanism of picking the mango fruit can be used for large area harvesting (Fig. 8). This system is suitable for fruits for local marketing of fruits which would be processed or consumed immediately. In the netting system, the fruit is injured while falling on the lower branches or on the other fruits. In this method of harvesting, a net is placed under the projected area of the tree (Fig. 8). The condition of the fruits five days after harvest was investigated in a store room. Normally, mangoes are consumed within five days of harvesting. The result of the investigation is shown in Table 6.

#### Cost of Harvesting

The cost of harvesting mango for the three existing methods is shown in Table 7. Harvesting operation was performed only once for each tree and the cost of grading, packing, transportation, etc were considered similar for all the three methods. One hundred trees were considered for harvesting in each method. The cost comparison for the three methods are summarized in Table 7. Hand-picking was the most expensive method in comparison to either topca or netting method. The harvesting losses for the three methods were not constant and the loss of harvesting using the netting mechanism was higher than either

**Table 6** Condition of Mango Fruits Five Days after Harvest (Expressed as percent of total samples, Langra variety)

Harvesting method	Undamagedfruit	Bruises	Punctures and Tears
Hand picking	93	4	3
Topca	80	13	7
Netting	67	20	13

**Table 7** Cost of Harvesting with Different Methods

Harvesting method	Hand picking	Topca	Netting
Type of material needed	Rope and bag	Topca	Net
System cost/unit (Tk.)	47	54	392
Labour required for 100 trees	10	8	2
Total system cost	470	432	784
Labour required for handling each system	2	2	5
Labour required for 100 trees	200	160	56
Labour rate (Tk./labour)	30	30	30
Total harvesting cost per 100 trees (Tk.)	6000	4800	1680
Total harvesting cost per 100 trees (Tk.)	6470	5232	2464
Ttotal harvesting cost per 100 trees (USS)	209	169	79

\*USS = Tk. 31.

two methods.

#### Problems of Harvesting

On the basiss of the present study the problems of harvesting as indicated by the mango growers are summarized below:

- i) The present method of harvesting is time consuming;
- ii) The structure of mango tree obstructs the harvesting process. The fruits are injured when they fall on the branches, ground, or collision with each other;
- iii) Most mango growers do not know how and when to harvest the fruit without bruises, punctures or tears. They do not care much about quality of the mango fruits;
- iv) Growers pay little care to increase the yield of trees and proper way of harvesting;
- v) Fruits do not mature at the same time—a major obstacle for introducing mechanical harvesting; and
- vi) Very little research work is being done on the improvement of the existing techniques of harvesting.

#### Suggestions

A few suggestions are outlined below for the improvement of the existing methods of harvesting mango:

- i) Tree training of young seedlings should begin at the nursery for obtaining the required structure and size of a tree for easy harvesting;
- ii) Mango growers should acquire knowledge through training and extension work for ascertaining the proper time and proper way of harvesting in order to obtaining satisfactory yield with minimum cost;
- iii) A mango research institute and other agricultural development organizations should undertake appropriate steps at developing improved harvesting technique and implements, and
- iv) Power lifting to pick fruits is a great labour saving in a large orchard and handling of fruit boxes by tractors equipped with fork attachments may be explored for efficient harvesting of mango.

(Continued on page 72)

# Agricultural Mechanization in Rajasthan, India



by  
**Ajay Kumar Sharma**  
 Asst. Prof.  
 Farm Machinery and Power Engg.  
 College of Technology and Agric. Engg.  
 Rajasthan Agric. Univ.  
 Udaipur, India

## Abstract

This paper deals with the identification of the constraints in the use of agricultural implements and machinery in the State of Rajasthan. The level of mechanization in agriculture is low due to the problems which are mostly social, economical and technical. Attempts are made to suggest various recommendations to overcome these problems.

## Introduction

Rajasthan is located between 23° to 30° latitude and 70° to 78° longitude. Its total geographical area is 342 239 km<sup>2</sup>. The area under cultivation is 10 234 000 ha and gross area under irrigation is

4 014 000 ha. The rural population represents about 79% of the total population of the State. Which is distributed as follows: workers, 31.5%, marginal workers 7.5%, and non-workers 60.9% (Table 2).

The average annual rainfall in the State is 58 cm and varies from 16 to 100 cm.

Table 3 shows land utilization in the State. The total cropped area is 18 877 000 ha of which only 21.2% area is under irrigation. Table 4 shows the area, production, and yield of principal crops in the State. In spite of the fact that the State has natural resources in abundance along with good climate and soil suitable for adopting agricultural mechanization, agricultural progress has been very slow.

## Constraints

Many constraints come in the way of mechanisation of agriculture in Rajasthan. They are natural calamities, land holding, irrigation facilities, utilization of draft power, energy resources and industrial infrastructure, and economic condition of the farmer.

## Natural Calamities

Most of time the State is hit by drought. As the rainfall is not well distributed throughout the year there is often excess or scarcity of water. There is large variation in annual rainfall in different parts of the State. Low and unevenly distributed rainfall has an adverse effect on crop yield and thus affects the financial condition of the farmer.

Table 1 Rajasthan at a Glance

Item	Year	Unit	Numbers
Area	1981	Sq. km.	342239
Population	1981	Nos.	34,261,862
Urban			7210508
Rural			27051354
Net area sown	1983-84	000 ha	16234
Area sown more than once	1983-84	000 ha	2643
Gross area irrigated	1983-84	000 ha	4014
Agricultural implements	1983		
Ploughs			2,986,657
Carts			1,004,327
Tractors			53,941
Oil engines			242,061
Electric pumps			202,143
Sugarcane crushers			25,034

Table 2 Distribution of Rural Population of Workers by Sex in Rajasthan, 1981

Classification	Male	Female	Total	% of total rural population
Main workers	7149	1380	8529	31.53
Cultivators	5242	995	6237	73.13*
Agricultural labourers	484	229	713	8.36*
Household industries, manufacturing, processing, servicing and repairs	206	28	234	2.75*
Other workers	1217	128	1345	15.76*
Marginal workers	163	1878	2041	7.54
Non-workers	6702	9708	16482	60.92

**Table 3 Land Utilisation in Rajasthan**

Classification	1982-83		1983-84	
	'000 ha	Percentage to total area	'000 ha	Percentage to total area
Geographical area (for land utilisation purposes)	34,235	100.00	34,235	100.00
Forests	2,151	6.23	2,163	6.32
Land put to non-agricultural uses	1,511	4.41	1,519	4.44
Barren and unculturable land	2,892	8.45	2,880	8.41
Permanent pastures and other grazing land	1,836	5.36	1,846	5.39
Land under misc. trees crops and groves	50	0.15	82	5.39
Culturable waste	6,195	18.10	5,741	16.77
Current fallow	2,020	5.90	1,915	5.59
Other fallow land	1,920	5.61	1,855	5.42
Net area sown	15,659	45.74	16,234	47.42
Area sown more than once	2,736*	17.47	2,643	16.29*
Total cropped area	18,395	53.73	18,877	55.14

\* Percentage to net area sown.

**Table 4 Principal Crops of Rajasthan**

Crops	Area (000 hectares)				Production		Yield (kg/ha)	
	1982-83		1983-84		(000 tonnes)		1982-83	1983-84
	Total	Irrigated	Total	Irrigated	1982-83	1983-84	1982-83	1983-84
Cereals	9,219	2,411	9,543	2,185	6,754	8,399		
Bajra	4,808	193	5,004	81	1,390	2,457	289	491
Jowar	951	18	985	5	356	591	374	600
Wheat	2,070	1,716	2,165	1,783	3,787	3,451	1,830	1,594
Maize	889	211	893	44	659	1,229	741	1,376
Barley	339	238	291	216	469	421	1,383	1,481
Small millets	44	1	45	1	6	22	119	480
Rice	118	34	160	55	88	218	740	1,358
Pulses	3,533	351	3,647	302	1,570	1,659		
Gram	1,756	329	1,797	285	1,318	1,089	751	606
Other Rabi pulse	34	14	34	11	27	24	810	749
Other Kharif pulse	1,721	7	1,788	5	217	532	126	296
Oilseeds	1,321	383	1,481	521	619	935		
Sesamum	449	3	477	1	41	65	91	173
Rape and mustard	607	348	821	502	444	649	731	791
Linseed	74	2	90	4	27	45	366	504
Groundnut	186	28	183	12	106	174	572	949
Castorseed	5	2	10	2	1	2	207	205
Cotton @000 bales of 170kg each	397	360	416	122	554	579	237	236
*Sugarcane	38	36	34	32	1,430	1,485	3,753*	4,418*
Tobacco	2	2	3	2	2	3	912	981
Chilles	38	34	34	32	24	50 Dry	640	856
Potatoes	2	2	2	2	3	7	1,714	3,511
Coriander	109	49	113	55	73	56	667	500

\* In terms of Gur.

Source: Basic Statistics, 1985, Government of Rajasthan.

### Land Holding

Land holdings of farmers in Rajasthan are very small and scattered because of which farmers are not able to make use of intensive cultivation. It is a major constraint for mechanized farming.

### Irrigation Facilities

Only 21% of the total cropped

area is under irrigation which is also confined to parts of eastern and northern Rajasthan. Some 16% of the cropped area is under multiple cropping. Low irrigation facilities do not permit the farmers to use inputs like fertilizer which consumption is only 12.91 kg/ha in comparison to the national average of 44.9 kg/ha.

### Utilization of Draft Power

Farm animals are the main source of power in rural Rajasthan and are engaged about 65-75 days a year in farming operations. Farmers are not aware of farm machineries as available power source.

### Energy Sources and Industrial Infrastructure

Some 60.9% of rural population represented by non-workers and only 2.6% is engaged as agricultural labourers.

### Economic Condition of Farmers

The farmers in the state fall under the category of small and marginal farmers. They have to struggle hard for their basic needs of life. They are highly conservative and spend inordinate amounts on social obligations like marriage, death and birth. They have to borrow from the village money lender at a high interest rate and remain always under debt. This debt, at times they are not able to pay off during their lifetime and so it is passed on from one generation to the next. Their economic condition does not permit them to go for agricultural mechanization. However, in the eastern and northern parts of Rajasthan where there are adequate irrigation and other facilities, farmers have better economic condition and are rapidly adopting agricultural mechanization.

### Progress in Agricultural Mechanization

Most of the farmers in Rajasthan follow the traditional animal-human power method of cultivation. The cropping pattern and the labour requirement for agricultural operation has marked influence on the mechanization status of the State. It has been observed that with the adoption of multicrop-

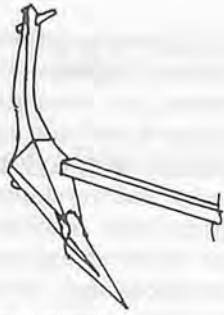

Fig. 1 Local plough.

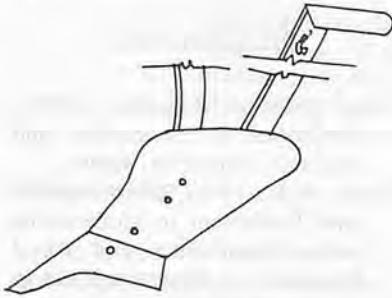

Fig. 2 Mould board plough.

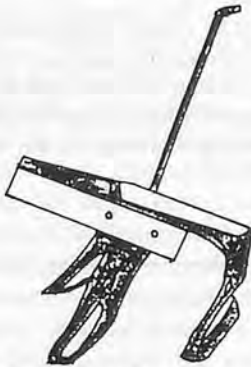

Fig. 3 Three-tyne cultivator.

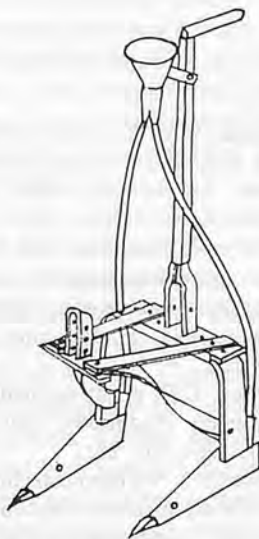

Fig. 4 Two-row seed drill.

ping system, the demand for labour has increased appreciably. The use of agricultural machinery is becoming popular among the farmers as it saves them labour and time, ensures timeliness of operation and reduces drudgery. Tillage operation is performed usually by locally made wooden plough (Fig. 1). The mould board plough (Fig. 2) introduced lately has adequate strength, provides deep penetration, better pulverization of soil, and high field capacity over local plough. Cultivators (Fig. 3) are also used as tillage implement by the farmers. The size of mould board plough and cultivator depends upon power source, soil, and operating conditions.

Three-tyne bullock-drawn cultivator and wooden *pata* are used for reducing the size of clods after ploughing. The combination of mould board plough and cultivator performs better and saves time.

The traditional method of sowing seeds by broadcasting and *pota* method is popular. In the latter method seeds are dropped by hand into the funnel attached behind the *desi* plough. Bullock-operated, two-row seed drill (Fig. 4) based on *pota* method is gaining popularity among the farmers. Farmers are now taking keen interest in the box type 3-4 row seed-cum-fertilizer drills which are easy to operate and have seed-cum-fertilizer box with fluted rollers provided below it to meter the seed and fertilizer.

Farmers in the State have realized that interculture is an important operation for obtaining

higher crop yield. The use of *desi* plough and *kudali* (manually operated) (Fig. 5) is traditional method of interculture. Bullock-drawn three-tyne cultivator and manually-operated wheel hoe require less labour and ensures timely weeding. These weeding tools are accepted by the farmers and are becoming popular for interculture operations.

Farmers are now becoming aware of plant protection measures against disease and pests. Knapsack sprayers both hand-compression and plunger pump types are in use throughout the State as plant protection equipment.

Harvesting of crop is usually done by locally-made sickles. Improved serrated sickles are now being introduced among the farmers. These sickles require less effort and give less fatigue to the operator and are being adopted by the farmers.

The common method of threshing is bullock-treading for crops like wheat, jowar, pulses, bajra and mustard. Maize seeds are usually shelled from cobs manually. These methods are time-consuming and tiring. Gradually the power-operated threshers and maize shellers (power and manually-operated) are gaining popularity among the farmers. Other equipment like groundnut decorticator are also gaining popularity.

Tractors used as power source on selected farms in the eastern and northern parts of Rajasthan range from 25-35 hp. Their use is limited mainly to primary tillage, sowing and transportation. Other field operations are carried out by animal-human power.

Stationary operations like threshing, oil expelling, rice milling, and lift irrigation are performed using electric motors or diesel engines. Electric motors and diesel engines are being adopted by



Fig. 5 Kudali.

the farmers at a very high rate.

The State is getting conscious of energy conservation. Studies are being carried out at various levels to reduce net unit operation cost by increasing the efficiency and capacity of agricultural machinery.

## Conclusion

The farmers in Rajasthan are inclined to use improved agricultural implements and machinery. Farm size influences the efficiency of mechanization as it is relatively easy to achieve economies of scale on larger farms. The capital investment in a mechanized farm is higher than that in traditional farming, but it provides better farm management and gives higher yields. Therefore, consolidation and cooperative farming becomes immediate need in the State. Steps should be taken to develop implements and machinery suitable for various climatic con-

ditions, soil types, and size of holdings.

Farm implements are manufactured at Government level by Agro-Industries, NAFEED, etc. and are made available to the farmers at subsidy prices. No headway could be made in agricultural mechanization in the State due to social customs, economic condition of the farmer, and lack of training and maintenance of agricultural machinery to the users. By improving these conditions progress in agricultural mechanization could be made.

## Steps to Promote Mechanisation

1. To develop a state policy on agricultural machinery.
2. To establish training centres for imparting training on selection, operation and maintenance of agricultural machinery.
3. To enforce established codes for agricultural machinery.
4. To encourage custom-hiring of farm equipment.

5. To accelerate the popularization of agricultural implements by strengthening different extension agencies.
6. To encourage activities for design and development of agricultural machinery to suit different agro-climatic conditions and farmers in the State.

## REFERENCES

- Basic Statistics, Rajasthan (1985). Directorate of Economics and Statistics, Rajasthan, Jaipur.
- Metha, M.M. (1985). Role of Agricultural Equipment in Modernizing Indian Agriculture and Rural Prosperity. A keynote address in the Silver Jubilee Convention of Indian Society of Agricultural engineers.
- Singh, S.N. (1988). Agriculture and Agricultural Mechanization in India, Journal of The Institution of Engineers (India), Agricultural Engineering Division, Vol 68, Pt AG 2: 57-61. ■■

---

(Continued from page 68)

## Mango Harvesting Techniques in Bangladesh

### REFERENCES

1. Ahmed, S. et al: Harvesting and Marketing of Mango Fruit. The Punjab Fruit Journal, 1960, pp. 160.
2. Mohsenin, N.N. and Gohlich: Techniques for determination of mechanical properties of fruits and vegetables related to design and development of harvesting and processing machinery, Journal of Agricultural Engineering Research, vol.7, 1962, No. 4, pp. 300-315.
3. Fridley, R.B. et al: Factors affecting impact injury to mechanically harvesting fruit. Transactions of ASAE, Vol.7, 1964, No.4, pp. 409-411.
4. Jawwarda, J.S. and K.K. Singh: Fruit Drop in some Mango Varieties of the Punjab Fruit Journal, 1966.
5. Chada, K.L. and K.K. Singh: Fruit Drop in Mango with its relation to fruit growth. Indian Journal of Horticulture, No. 21, 1972, pp. 198.
6. Hayes, W.B.: Fruit growing in India. 6th edition, 1966, pp. 75-76 and 189.
7. Garden, V.R.: Basic Horticulture. The Macmillan Company, New York, 1st edition, 1951, pp. 210-215.
8. F. Winter, Bavendorf: Zur Frage des zweckmassigsten Anbausystems beim Apfel, Obstbau, 5 Mai 1983, 8. Jahrgang, pp. 212-220.
9. Richey, C.B. et al: Agricultural Engineers Handbook, 3rd edition, 1961, pp. 281.
10. Moser, E.: Verfahrenstechniken fur die maschinelle Traubenente, Grundle. Landtechnik, Vol. 29, No. 3, 1979, pp. 78-83. ■■



# Fog Emitters as Evaporative Cooling Devices for Dairy Cow Sheds

by  
Abdelhafeez M. Abdalla  
Dept. of Agric. Engg.  
College of Agriculture and Food Sciences  
King Faisal Univ.  
Al-Hasa, Saudi Arabia

R. Narendran  
Dept. of Animal and Poultry Production  
College of Agriculture and Food Sciences  
King Faisal Univ.  
Al-Hasa, Saudi Arabia

## Introduction

The effects of thermal stress — particularly high ambient temperature, on dairy cattle have been extensively studied in the past four decades (Ragdale et al, 1949; Brody, 1956., Johnson, 1965; Brown et al, 1969; Maust and McDowell, 1971; Hahn, 1974; Ingraham et al, 1974 and Dooley, Fuquay and Gonzales, 1980). During the same period various systems of environmental modifications have also been developed to reduce air temperature and thus alleviate thermal stress in dairy cattle housed under hot and arid conditions (Hahn and Osburn, 1970, Rousel and Beatly, 1970, Wiersma, Stott and Lough, 1972; Buffington et al 1978; and Barth, 1982). The evaporative cooling system using the fan and wetted pad combination has been accepted to be the most effective, practical and economically feasible under hot and arid climatic conditions. Water spray injection or fogging systems have also been used for cooling animal housing to a limited extent. Timmons et al (1980) compared the wetted pad evaporative cooling system with low and high pressure fog emitting evaporative cooling systems and concluded that the wetted pad offered the greatest cooling poten-

tial but required powered ventilation to force air through the pad. However, one of the potential advantages of the fogging system is its suitability for open sheds. The fan and pad system requires that the animal be confined in closed housing.

The objective of the present study was to investigate the effectiveness of a high pressure fogging system under the hot and arid conditions in the Al-Hasa area of Saudi Arabia during the summer months, in cooling open dairy sheds.

## Materials and Methods

The fogging system installed in the present study consisted of a pump capable of pumping water at a pressure of 3 000 K Pa and a system of high pressure tubes with fine nozzles and control valves. The open dairy shed was

7.2 m × 10 m in area and had a 0.9 m wide window placed 1.2 m from the ground and 1.0 m from the ceiling. The window was on the northern and southern sides of the shed, while the eastern and western sides were completely walled in. The window was covered with 'Tildanet' plastic fabric which served as windbreak, hence cut down the rate of wind flow by approximately 40% (Fig. 1)

Four high pressure water pipes were extended along the width of the shed 2.0 m apart at a height of 2.0 m above the floor (approximately 1.0 m below the ceiling). Low volume, high velocity nozzles were installed at 6.0 m intervals along each high pressure tube. The nozzles were capable of generating fog with ultra fine droplets (3.0  $\mu$ ).

Four different nozzle orientations were tested — horizontal (fog emitted horizontally against

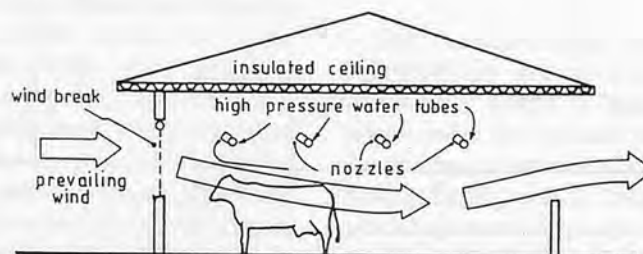

Fig. 1 Experimental shed and arrangement of high pressure water tubes.

the flow of the prevailing wind), 30° with the horizontal and 60° with the horizontal (fog emitted partly upward in to the prevailing wind), and vertically up (fog emitted towards the ceiling). The dry bulb and wet bulb temperatures and the air velocities both inside and outside the shed were measured between 1200 and 1400 during 10 different days (not consecutive) during the summer of 1984. The fog formation patterns from the nozzles with the different orientations were visually observed. The vertical and horizontal fog deflection due to wind flow was measured by means of a black screen with 0.1 m grid of white lines. The screen was placed behind the nozzles parallel to the wind flow during measurements.

Cooling efficiency was defined as,

$$(t_o - t_i)/(t_o - t_{wb}) \times 100\%$$

where,

$t_o$  = ambient dry bulb temperature outside the shed

$t_i$  = ambient dry bulb temper-

ature inside the shed  
 $t_{wb}$  = ambient wet bulb temperature outside the shed

## Results and Discussion

Measures of the physical environment conditions both inside and outside the shed during the period under study are presented in Table 1 for all nozzle orientations. The ambient temperatures recorded both inside and outside the shed during the study period and the cooling efficiency of the

foggers are presented in Figs. 2 and 3, respectively. The schematic representation of the visually observed fog distribution patterns for each nozzle orientation as affected by the highest and lowest wind velocity recorded is presented in Fig. 4.

The lowest ambient dry bulb temperatures inside the experimental shed were obtained with the horizontally oriented nozzles, while the highest were recorded with the vertically oriented nozzles. Nozzle orientations of 30° and 60° with horizontal were as-

**Table 1** Prevailing Environmental Conditions Outside and Inside Experimental Shed During the Period between 22/6 and 22/7/1982.

	Outside conditions				Inside conditions							
	Dry bulb °C	Wet bulb °C	Wind speed m/s	Air speed m/s	Dry bulb temp. at nozzle orient				Cooling efficiency, %			
					Horiz	30°	60°	Vert. up	Horiz	30°	60°	Vert. up
1.	40.5	20.3	3.5	1.7	32.8	33.2	33.8	34.5	38	36	33	29
2.	41.8	21.2	4.4	2.1	34.4	34.8	35.6	36.2	36	34	30	27
3.	40.6	20.5	2.5	1.5	32.6	33.2	33.8	34.2	40	37	34	32
4.	42.3	21.2	3.3	2.8	36.1	35.5	36.4	37.0	34	32	28	25
5.	45.1	22.5	2.7	1.1	34.5	35.2	36.0	36.7	44	44	41	40
6.	44.4	22.4	2.0	1.0	33.2	33.8	35.3	35.7	51	50	48	45
7.	41.4	20.6	7.4	3.1	37.6	37.6	38.2	38.8	18	18	15	12
8.	43.8	21.2	5.2	2.1	37.7	38.3	39.0	39.6	27	24	21	18
9.	42.0	21.4	8.0	2.8	38.6	39.1	39.5	39.8	21	19	17	15
10.	43.5	21.5	2.7	1.5	35.4	36.0	36.8	37.3	37	34	30	28

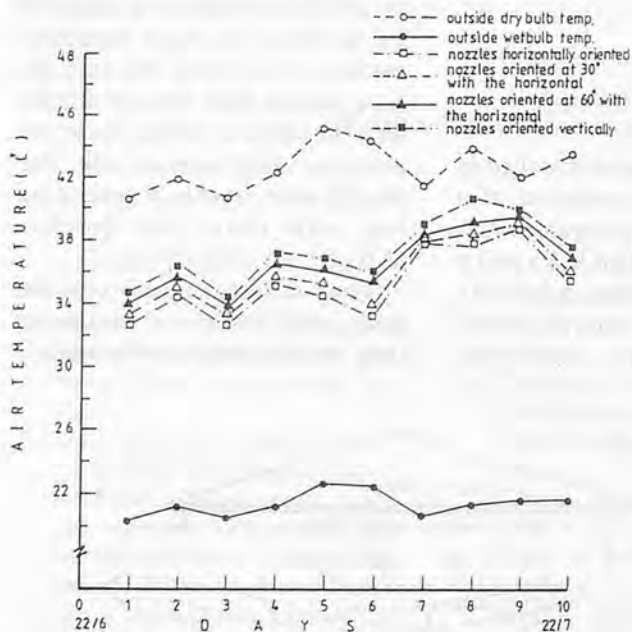

**Fig. 2** Prevailing air temperature inside and outside experimental shed during the period between June 22-July 22, 1982.

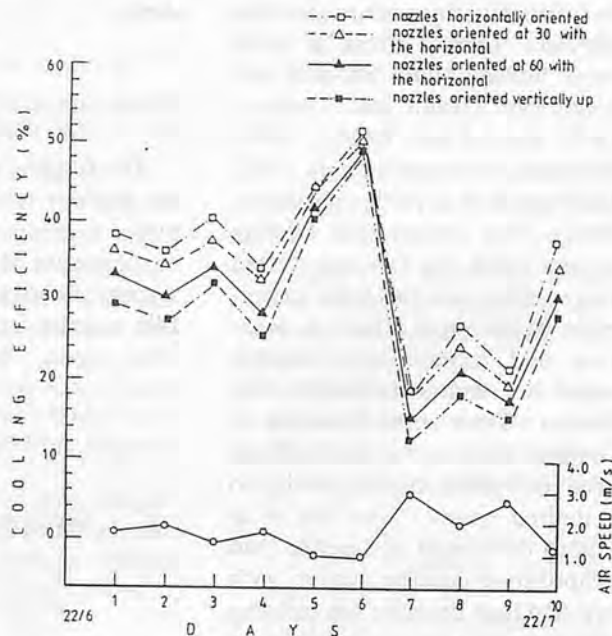

**Fig. 3** Cooling efficiency of foggers as affected by nozzle orientation and air velocity.

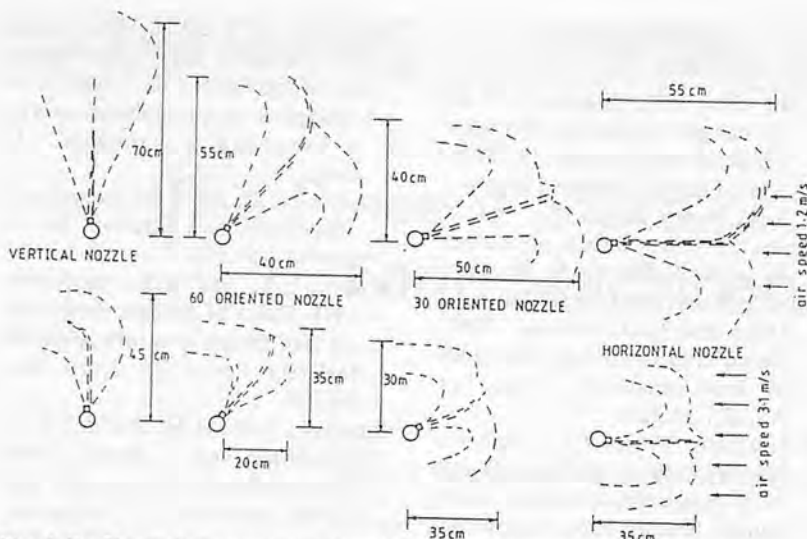

Fig. 4 Fog formation pattern as affected by nozzle orientation and air speed.

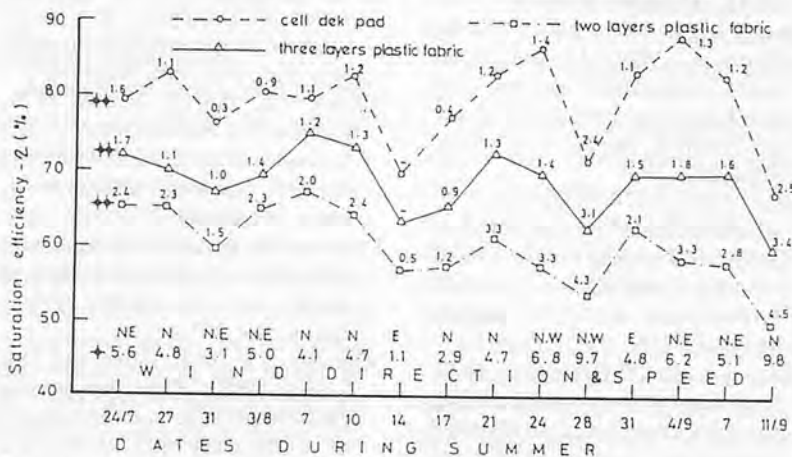

Fig. 5 Saturation efficiency ( $\eta$ ) of the three types of wetted pads used in the experimental work. \* wind velocity, m/s and \*\* air speed through pad, m/s.

sociated with intermediate values. The above trends were consistent throughout the experimental period. However, the dry bulb temperature depression was rather low in all cases, varying between 3.8 and 11.2°C for the horizontally oriented nozzles and between 2.8 and 8.7°C for the vertically oriented nozzles. The corresponding cooling efficiency varied between 18-51% and 12-39% for the horizontally and vertically oriented nozzles, respectively.

With the horizontally oriented nozzles, the fog emitted horizontally into the incoming air seemed to be getting more thoroughly mixed with the incoming air mass.

This results in greater vaporization of the fine water droplets and brings about a greater cooling of the air mass wafting through the shed. The vertically oriented nozzles, on the other hand, emitted the fog upwards towards the ceiling and the fog was thus exposed to more wind deflection. This resulted in a greater part of the fog being carried outside the shed, especially when wind velocities exceeded 3.0 m/s. While on relatively calm days when the wind velocities were low, the fog tended to condense on the ceiling and drip on the cows and floor, resulting in excessively wet conditions within the shed.

High wind velocities and the resulting high rate of air flow through the shed seemed to adversely affect the cooling efficiency of the foggers irrespective of nozzle orientation. The vertically and 60° oriented nozzles were the most adversely affected due to the excessive drifting of the fog to the outside. Cooling efficiency was higher for all nozzle orientations on days when air velocity was around 1.0 m/s.

Notwithstanding its superiority in cooling efficiency, horizontally oriented nozzles seemed to have certain practical disadvantages, the most serious of which was fog descent and condensation on cows on days when the wind velocities were low. This resulted in excessively wet conditions that predisposed the cows to health problems (respiratory diseases and mastitis, in particular). Further, the droplets of water remaining on the horizontally oriented nozzles after the fogging system was shut off, led to the progressive accumulation of salts and the eventual blockage of the nozzle orifices. The nozzles oriented at 30° with the horizontal experienced this problem to a lesser extent. The nozzle orientation at 60° with the horizontal, despite its lower cooling efficiency compared to the horizontal orientation, seemed to have the advantage over the latter, in that it resulted in considerably less wetting and considerably less nozzle blockage.

## Conclusions

Fog emitters seem to have potential for use as a thermal stress relief system in open dairy sheds under the hot arid climatic conditions prevalent in the Kingdom of Saudi Arabia. Despite the advantage the horizontally oriented nozzles have in terms of cooling efficiency over the vertical, 60°

and 30° oriented nozzles, the problems of excessive wetting and nozzle blockage encountered with it suggest that the 60° oriented nozzles would be the ideal compromise. The 60° oriented nozzles while having a satisfactory cooling efficiency would be less associated with excessive wetting and nozzle blockage. Relatively heavy fabric wind breaks should be stretched across the windward side of open sheds to cut down the wind velocity by at least 50%. This would contribute towards optimizing the efficiency of the foggers.

### Summary

The suitability of the micro-mist fogging system for cooling open dairy sheds under the hot and arid summer conditions prevalent in the Kingdom of Saudi Arabia was evaluated. Several nozzle orientations — vertical, horizontal, 30° to horizontal in an upward direction and 60° to horizontal in upward direction, were compared. It was concluded that the 60° nozzle position is the best compromise in terms of cooling efficiency and minimization of problems of excessive wetness in the shed and nozzle blockage due to salt residues from water.

### REFERENCES

- Bath, C.L. 1982. State of the art for summer cooling for dairy cows. Livestock environment 11, Proc. Second Intern. Livestock Environ. Sym., Ames, Iowa: 52.
- Brody, S. 1956. Climatic physiology of cattle. *J. Dairy Sci.*, 39:715.
- Brown, W.H.; M.D. Shanklin; G.L. Hahn and H.D. Johnson. 1969. Rectal temperature rise on an index of heat sensitivity. *Trans. of ASAE.*, 12:225.
- Buffington, D.E.; T.C. Skinner; Barbara Collette and Daniel Borer. 1978. Evaporative cooling for hot humid climates. Proc. Southwest-Southeast regional meeting of ASAE, Houston, Texas.
- Dooley, R.L.; J.W. Fuquay and R. Gonzales. 1980. Environmental stress management systems for lactating dairy cows. ASAE paper No. 80-4016, ASAE, St. Josephs, Missouri.
- Hahn, G.L. 1974. Discussion of environmental effects on ruminant production-rational decisions based on current knowledge. In *Livestock Environment*, ASAE, St. Joseph, Missouri: 232.
- Hahn, G.L. and D.D. Osburn. 1970. Feasibility of evaporative cooling for dairy cattle based on expected production losses. *Trans. of ASAE.* 13:294.
- Ingraham, R.H.; D.D. Gillette and W.D. Wagner. 1974. Relationship of temperature and humidity to conception rate of Holstein cows in a subtropical environment. *J. Dairy Sci.*, 57:476.
- Johnson, H.D. 1965. Environmental temperature and lactation. *Int. J. Biomet.*, 57:103.
- Maust, L.R. and R.E. McDowell 1971. Effect of summer conditions on feed intake and milk yield of Holstein cows. *J. Dairy Sci.* 54:793.
- Ragsdale, A.D.; D.M. Worstel; H.J. Thompson and S. Brody. 1949. Environmental physiology and shelter engineering. VI. Influence of temperature up to 105°F and 50 to 95°F on milk production, feed, water consumption and body weight in Jersey and Holstein cows. *Mo. Agr. Exp. Stn. Bull.*: 449.
- Rousel, J.D. and J.F. Beatly. 1970. Influence of zone cooling on performance of lactating cows during stressful summer conditions. *J. Dairy Sci.* 53:1085.
- Timmons, M.B. and G.R. Baugman. 1980. Experimental evaluation of poultry mist-fog systems. *Trans. ASAE.* 26: 207.
- Wiersma, J.F; G.H. Stott and Otis Lough. 1972. Consider cooling possibilities: The practical aspects of cooling dairy cattle. Publication 25. University of Arizona. ■■

## The Present State of Farm Machinery Industry

by  
Farm Machinery Industrial Research Corp.  
7, 2-chome, Kanda Nishikicho,  
Chiyoda-ku, Tokyo, 101 Japan

### Outlook of Agriculture

#### Trend of Agriculture

Agricultural production in 1989 generally exceeded that of the previous year.

The plowland of rice field, under oversupply, decreased 13,000 ha (compared with the preceding year) to 2,097,000 ha. The crops were 10,347,000 t, which showed an increase over the preceding year. As to wheat, the plowland was 397,000 t (which remains about the same level as the preceding year), while the crops were 1,356,000 t. This means a decrease over the preceding year. Soybean resulted in the yield of 272,000 t, which showed a decrease over the preceding year.

With regard to the trade of agricultural products, the imports are on the increase: per food, cut flowers, flours, whisky, orange juice and so on.

Farming population decreased 3% over the preceding year to 4,190,000 persons. Of the farming population, men amounted to 2,070,000 in all.

Farm houses are continuously decreasing to 4,194,000 farm houses in 1989. Of all these farm houses, full time farm houses are only 603,000 houses.

Farm income in 1989 increased

13%, compared with the preceding year. The ratio of farming income to the total income in merely 14%.

Agricultural investment in 1989 was as much as the preceding year, while the investment in agricultural machinery showed a decrease again. The total investment amounted to ¥173,000 per farm houses.

In Japan food life has become rich since the 1970's. On the other hand, rice crop, oranges, milk, and eggs were over produced. Food industry has developed and imports of agricultural products showed a sharp increase.

Japanese agriculture is requested to reduce the production cost and to produce the high quality, various agricultural products which consumers are asking for.

#### Trend of Farm Mechanization

Agricultural mechanization in Japan has remarkably progressed in the field of low land rice, chief crop, in a short period since 1955. Thus, continuous system of low land rice has completed. 98% of rice crop is transplanted and 99% of rice crop is harvested by farm machinery in 1989. As to rice crop, working hours per 10 a decreased to 46.1 hours—they were 117.8 hours in 1970.

In recent years farm machinery for rice crop is developed to be larger-sized, higher-efficient and more commonly used. In addition, farm machinery for field crops and livestock farming is being developed and improved, which has been lagged behind so far. Whatever the types it may be, farm machinery is being improved from various points such as performance, safety and cost reduction.

Followings are the number of popularization of farm machinery as of Jan. 1, 1989: riding tractor amounted to 2,049,000 units; walking tractor 2,654,000; rice transplanter 2,205,000; head feed combine 1,258,000 (Table 1 and Fig. 1).

Shipments of major farm machinery in the domestic market in 1989 are as follows: riding tractor reached 90,000 units; riding tractor 215,000; transplanter 88,000; power pest control machine 283,000; power reaper 37,000; combine 65,000; dryer 59,000; huller 39,000 (Table 2).

Recently there is a larger demand for used farm machinery. In 1988 the rate of used machinery in the distributing amount is as follows: riding tractor forms 42%; transplanter 32%; combine 35%.

The total investment in farm

**Table 1** Major Farm Machinery on Farm

Unit: Thousand								
Year	Walking type tractor	Riding type tractor	Rice transplanter	Power sprayer	Power duster	Binder	Combine	Rice dryer
1984	2,842	1,650	2,062	1,690	2,021	1,672	1,042	1,677
1985	2,579	1,854	1,993	2,151		1,518	1,109	1,473
1986	2,554	1,834	2,098	—	—	—	1,150	—
1987	2,682	1,904	2,179	—	—	1,275	1,201	1,378
1988	2,674	1,985	2,199	1,408	1,674	—	1,244	—
1989	2,654	2,049	2,205	—	—	—	1,258	—

Source: "Statistical Yearbook of Ministry of Agriculture, Forestry & Fisheries" by the Ministry of Agriculture, Forestry & Fisheries and Other datas.

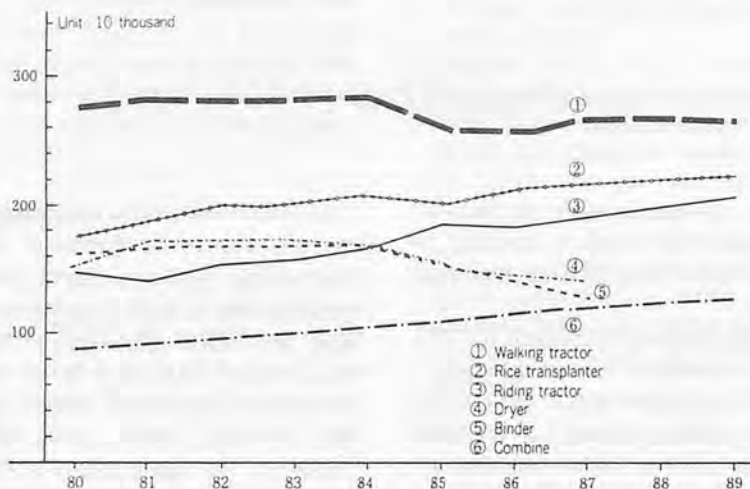

**Fig. 1** Selected farm machinery on farm.

**Table 2** Shipment of Major Farm Machinery

Unit: Number								
Year	Walking type tractor	Riding type tractor	Rice transplanter	Power sprayer	Power duster	Binder	Combine	Rice dryer
1984	214,079	99,606	123,915	132,048	133,521	58,336	86,992	74,587
1985	195,589	103,859	126,967	128,353	136,970	49,908	95,676	78,304
1986	184,005	109,101	122,441	132,447	133,479	52,234	88,997	74,636
1987	184,885	90,940	101,942	140,635	123,674	44,746	79,278	66,662
1988	213,941	90,261	84,531	144,705	108,958	39,950	66,618	59,666
1989	214,806	89,676	88,441	168,232	110,969	36,789	65,046	58,614

Source: "Survey of Shipment of Agricultural Machinery" by the Ministry of Agr., Forestry & Fisheries.

machinery per farm household reached ¥173,000 in 1989.

### Measure of Farm Mechanization

The budget of agricultural, forestry and fishery for 1990 amounted to ¥3,122.1 billion, which shows a decrease of 1.2% compared with the preceding year.

The budget of agricultural and forestry is mainly compiled, laying emphasis on the following respects: to reduce cost; to produce agricultural crops in

response to the trend of the demand; to promote researches for the increase in the additional value of agricultural products; to preserve the environment on the earth; to reinforce international cooperation; and to make mountainous districts lively.

Enterprises for agricultural mechanization are incorporated into measures which aim at giving life to agriculture and rural districts, enlarging the scale of leading farmers who assume the

responsibility of agricultural production, making the most of high-technology and information, promoting agriculture among hills and chief producing districts for high productivity.

In the introduction and use of farm machinery, it is most important to reduce production cost under the rational use of high-performance farm machinery, to popularize simple farm machinery equipped with fundamental function and at a low price, to make an efficient use of used farm machinery and to prevent accidents in farm working.

### Movement of Farm Machinery Industry

The output of farm machinery, which increased sharply in 1973 and 74, amounted to ¥659.0 billion. But it decreased sharply to ¥536.7 billion in 1978 because farmers were unwilling to invest money in machinery under the popularization of rice crop machinery and under the policy of reducing the acres for rice planting.

Except for ¥627.3 billion in 1980, since 1978 the output remained about ¥500 billion p.a. The output has a gradual increase to ¥633.8 billion in 1984, ¥667.8 billion in 1985 and to ¥674.3 billion in 1986. Because international markets are developed and high value-added products are developed. In spite of these increasing tendency, in 1987 the output decreased ¥500.0 billion again. Since then, it remained about ¥550.0 billion.

Through other industries are showing signs of prosperity, the farm machinery industry is depressed. Japanese farm machinery manufacturers are striving for making their business market active by stirring up new demand for farm machinery,

produce for other industries as subcontractors, finding a market in other industries except for farm machinery. Now, we are more and more shorthanded. It is urged to improve working hours, wages and working environment.

### Trend of Farm Machinery Production

In 1989 the amount of farm machinery production was ¥553.4 billion, which increased by 0.6% over the preceding year. Agricultural circumstances cannot be improved still now, but the production just barely remained as much as that of the preceding year.

Production of major farm machinery is as follows: riding tractor decreased by 8.8% over the preceding year to 158,000 units. By sizes, those under 20 ps amounts to 74,000 units, those from 20 to 30 ps 57,000 units and those over 30 ps 27,000 units.

The production of walking tractor amounted to 276,000 units, which remained as many as that of the preceding year. By sizes, compared with the preceding year, those under 5 ps on the decrease and those over 5 ps on the increase.

The production of combine, which is next to riding tractor, is 65,000 units. This is an increase of 0.6% over the preceding year.

Followings are the production

of other types of farm machinery: rice transplanter amounts to 88,000 units (an increase of 8.1% over the preceding year); grain dryer 56,000 units (a decrease of 4.4%); bush cleaner 1,689,000 units (an increase of 9.3%); huller 47,000 units (a decrease of 4.8%); binder 37,000 units (a decrease of 9.5%); thresher 24,000 units (a decrease of 3.9%) (Table 3).

### Trend of Farm Machinery Market

In Japan distribution system for farm machinery is roughly divided into two major channels: the traders concerned and Agricultural Cooperative Association. As

Table 3 Yearly Production of Farm Machinery

Unit: Number, Million Yen

Year	Farm machinery total		Riding type tractor		Walking type tractor		Rice transplanter		Power sprayer		Power duster		Blower sprayer	
	Quantity	Value	Quantity	Value	Quantity	Value	Quantity	Value	Quantity	Value	Quantity	Value	Quantity	Value
1984	—	638,803	201,357	240,051	361,649	45,299	131,966	54,219	166,226	10,720	242,289	8,746	6,651	8,091
1985	—	667,895	209,652	247,100	278,581	41,398	132,909	53,835	170,968	10,479	222,877	7,755	7,200	8,361
1986	—	647,265	209,078	254,010	268,307	37,026	134,433	64,541	157,774	9,754	184,132	6,374	7,121	9,535
1987	—	585,810	179,884	215,379	276,286	38,778	92,861	50,181	144,734	8,396	165,241	6,028	6,231	8,296
1988	—	549,854	172,761	209,278	276,684	37,644	81,022	43,554	181,805	9,851	161,763	5,999	8,696	9,958
1989	—	553,368	157,544	197,947	275,629	38,735	87,615	46,337	184,098	10,015	156,802	5,845	9,901	9,400
(1990)	—	579,200	159,000	200,100	257,000	36,500	89,000	49,600	199,000	11,000	152,000	5,600	10,000	9,500

Year	Grain reaper		Bush cutter		Power thresher		Grain combine		Rice husker		Dryer		Grain polisher	
	Quantity	Value	Quantity	Value	Quantity	Value	Quantity	Value	Quantity	Value	Quantity	Value	Quantity	Value
1984	59,177	14,698	1,429,203	30,553	46,879	15,276	94,598	128,121	67,522	15,394	77,099	40,020	77,133	4,996
1985	51,061	12,274	1,350,990	24,573	42,901	15,163	102,593	157,222	80,231	19,661	76,571	42,634	75,314	3,843
1986	55,587	13,777	1,496,433	27,191	41,295	15,246	93,080	150,188	72,000	19,060	73,798	44,590	66,891	3,537
1987	45,867	10,292	1,421,007	24,569	29,126	10,430	78,656	131,265	57,087	16,300	65,378	44,192	61,367	3,083
1988	41,204	9,313	1,546,010	26,160	24,811	8,900	64,412	117,132	49,866	13,137	58,097	37,649	58,982	2,932
1989	37,291	8,841	1,689,181	28,501	23,835	9,005	64,789	127,309	47,478	13,900	55,537	35,244	61,298	3,223
(1990)	40,000	10,500	1,600,000	26,500	21,900	8,800	69,000	137,800	60,000	18,000	59,800	40,400	56,200	4,600

Source: "Survey of Status of Machinery, Production" by the Ministry of International Trade and Industry. Data by Japan Agr. Machinery Manufacturers' Assn. and Land Internal Combustion Engine Manufacturer's Assn.

Note: Data for 1990 are forecast by Farm machinery Industrial Research Corp.

Table 4 Farm Equipment Distributor and Sales Value

Unit: Million yen

Year	No. of retailers (1)	Employees	Annual sales value (2)	Inventory	Square meters of shop m <sup>2</sup>	Annual sales value (2)/(1)
1976.5	8,417	43,819	811,535	199,672	740,785	96.4
1979.6	9,257	48,548	1,007,298	159,772	898,854	108.8
1982.6	10,084	49,081	1,018,983	164,269	1,005,546	101.0
1985.6	9,142	43,921	946,507	144,837	985,453	103.5
1988.6	9,444	45,952	1,015,304	159,798	923,726	107.5

Source: Ministry of International Trade and Industry.

Table 5 Handling of Farm Equipment by Agricultural Cooperative Association (1988 Business Year)

Unit: Million yen

Business year	Total number of coops. surveyed	Purchase in this term	Of which purchased through affiliated organs	Amount of supply and handling
1983	4,306	312,835	239,746	341,195
1984	4,274	330,717	254,464	363,707
1985	4,242	345,606	268,640	378,441
1986	4,194	351,484	275,591	383,023
1987	4,117	333,131	260,530	364,716
1988	3,976	337,970	259,915	379,709

Source: "Statistics on Agricultural Cooperatives—1988 business year—" by the Ministry of Agriculture, Forestry & Fisheries.

**Table 6** Export of Farm Equipment 1989

Unit: FOB Million Yen

Year	Unit	Value	Ratio	Major destinations
1984		185,380		
1985		190,305		
1986		150,792		
1987		135,354		
1988		130,492		
1989		131,042	100.0	U.S.A., France
Power tiller	60,586	4,117	3.1	France
Wheel tractor	77,897	56,084	42.8	U.S.A.
Power sprayer	34,507	1,201	0.9	Taiwan, Iran, U.S.A.
Duster	26,571	754	0.6	Iran
Lawn mower	272,852	16,744	12.8	France, U.S.A.
Brush cutter	1,180,032	26,541	20.3	U.S.A., France, Italy
Mower	35,046	2,478	1.9	U.S.A., France
Combine	2,142	3,952	3.0	Korea, Taiwan
Blade, knife	—	1,433	1.1	U.S.A., Italy, Korea
Chain saw	174,895	3,994	3.0	U.S.A., France
Other		13,744	15.4	

Source: Ministry of Finance. Totaled by Japan Farm Machinery Manufacturer's Assn.

**Table 7** Import of Farm Equipment 1989

Unit: CIF Million Yen

Year	Unit	Value	Ratio	Exporters
1984		15,812		
1985		15,303		
1986		17,425		
1987		20,949		
1988		23,095		
1989		27,245	100.0	W. Germany, U.S.A., France
Wheel tractor	3,834	10,591	38.9	U.K.
Pest control machine	1,311,831	1,131	4.2	U.S.A., Israel, Taiwan
Lawn mower	60,299	2,145	7.9	U.S.A.
Mower	1,896	906	3.3	France, Denmark
Hay making machine	2,890	1,109	4.1	Netherlands, W. Germany, France
Bayler	1,548	1,863	6.8	France, U.S.A., W. Germany
Combine	257	2,174	8.0	W. Germany, Belgium, Italy
Chain saw	54,010	1,831	6.7	W. Germany, Sweden
Other		5,495	20.1	

Source: Ministry of Finance. Totaled by Japan Farm Machinery Manufacturer's Assn.

of June, 1988, the retail shops for farm machinery, including the traders concerned and Agricultural Cooperative Association were recorded to be about 9,400, the employees amounted to be about 45,000 persons, and the annual sales amounted to be ¥1,015 billion (Table 4).

According to the governmental survey by Ministry of Agriculture, Forestry and Fishery, the total sales by Agricultural Cooperative Association reached ¥379.7 billion in 1988 (Table 5).

Under the declining demand for farm machinery, the farm machinery distribution industry is making efforts to expand facilities and technique, and to rationalize the management. Now, it is urgent necessity that working environment should be consolidated to maintain manpower because labor shortage has become more serious.

## Export and Import of Farm Machinery

### Export

In 1989 the exports of farm machinery amounted to ¥131 billion, which showed an increase of

0.4% over the preceding year. The ratio of the exports to the total amounts ¥553.4 billion of the production ended in 23.7%.

Seeing from the shipments, those for the North America and Europe is on the decrease over the preceding year, while those for Asia and Oceania is on the increase. The exports for the United States, the largest market, reached ¥50.3 billion and the amount forms 38.3% of the total exports.

As for the types of farm machinery, tractor was chiefly exported. 158,000 tractors were produced in 1989. Of the tractors 78,000 units were exported, which amounted to ¥56.1 billion. Seeing by sizes, the exported tractors under 30 ps amounted to 62,000, those from 30 ps to 50 ps were 12,000, those more than 50 ps were 3,400 units.

Major farm machinery, next to tractor, is bush cleaner. The total exports were 1,180,000 units and ¥26.5 billion (Table 6).

The export of farm machinery in Japan has shown no remarkable fluctuation for three years running. Money is positively invested in foreign countries. Much more

companies are making efforts to tie up technically with companies on the spot, to establish factories and expand the trading and production base.

### Import

In 1989 the imports of farm machinery amounted to ¥27.2 billion, which means an increase of 18% over the preceding year.

Followings are the major imported farm machinery: tractors amounted to 3,834 units (those more than 70 ps were 2,870 units of all the tractors); chainsaw were 54,000 units (Table 7). ■■



## Outline and Activities of National Agriculture Research Center



by  
Takashi Kuwana  
Director  
Department of Farm Mechanization  
National Agriculture Research Center  
3-1-1, Kannondai, Tsukuba 305, Japan

### Introduction

Today, Japanese agriculture is confronted with various problems such as ① overproduction of rice, low production of wheat, forage crops and edible oil seed, ② higher price of agricultural commodities including livestock products compared with market levels worldwide, ③ increase in the number of part-time farmers, and ④ declining interest in agriculture in the younger generation.

To overcome these difficulties and to improve Japanese agriculture in taking account of the complexity of the natural environment of the country, it is essential to increase the productivity of all crops, particularly rice, wheat, soybean and forage crops, and also to lower the production cost through intensive land utilization and expansion of farm scale.

The National Agriculture Research Center (NARC) is entrusted with the development of the technologies required to solve the above mentioned problems not only by conducting specialized studies, but also by integrating and coordinating the results obtained by other research organizations.

### History of NARC

Dec. 1923 Founded as the Central Agricultural Experiment Station, Konosu Experiment Farm, Ministry of Agriculture and Forestry.

Apr. 1950 Re-established as the Kanto-Tosan Agricultural Experiment Station

Dec. 1961 Reorganized as the National Agricultural Experiment Station functioning as both central agricultural experiment station and Kanto-Tosan regional station.

Jan. 1973 Expanded to cover the Kanto, Tosan, and Tokai districts after the closure of the Tokai-Kinki Regional Agricultural Experiment Station.

Dec. 1979 Reorganized as the National Agricultural Experiment Station, Upland Farming Research Center in Tsukuba Science City.

Dec. 1981 Reorganized as the National Agriculture Research Center (NARC) in Tsukuba Science City to act as a coordinating organization for all the regional agricultural experiment stations and also for the establishment of an integrated technological system to contrib-

ute to the promotion of agricultural production.

Dec. 1983 Expanded and reorganized when two new institutes, the National Institute of Agrobiological Resources and the National Institute of Agroenvironmental Science were established in Tsukuba.

### Organization and Research Activities

Fig. 1 shows the overall organization chart of the NARC.

NARC's research activities can be broadly classified into three categories:

① Integrated research related to the establishment of agricultural production systems in utilizing research results obtained in various specialized fields of agriculture.

② Specialized research related to farmland utilization, farm mechanization, improvement of varieties and cultivation methods of main crops, disease and insect-pest control, soil and fertilizers, and research on rural development and farm management.

③ Research related to regional agriculture in the Kanto and

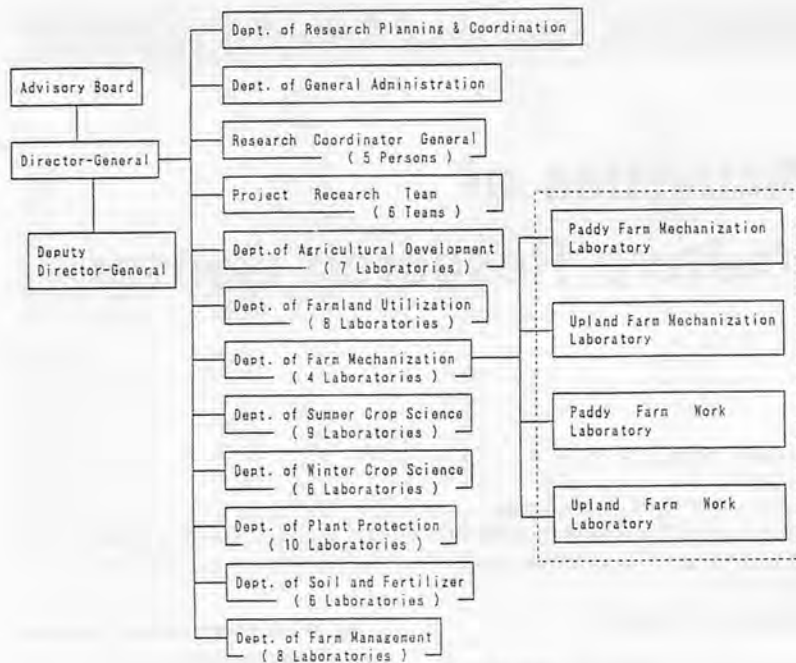

Fig. 1 Organization of NARC.

Tokai districts.

To fulfil these objectives NARC is composed of eight research departments, each engaged in one particular area of specialized research. Integrated research is promoted primarily under the guidance of 5 research coordinators general and 6 project research teams.

The following subjects are executed.

### Crop Production

Breeding programs for rice, wheat, barley, and sweet potato are carried out to release excellent cultivars with better quality, higher yielding ability, higher resistance to diseases and insect pests, and other desirable characteristics such as strong culm and early maturity in the case of some crops. To promote the breeding programs, gene resources are being collected both overseas and in Japan. New breeding methods such as heterosis breeding in rice, and haploid breeding using wild barley for wheat improvement are being developed. Research is also

carried out to analyze the physiological and ecological characteristics of crops to increase their ability to utilize with maximum efficiency solar energy for biomass production along with improving their photo-synthetic function. Methods of cultivation and selection of crop varieties and cultivars are promoted with a view to stabilizing and increasing yields. In addition, systematized technology is developed with a view to increasing and stabilizing the yield of crops cultivated in converted paddy fields.

### Production Environment

1) *Soils and fertilizers*—In order to preserve the soil environment which is associated with the high productivity of cultivity soil, the properties of soil of lowland paddy fields and upland fields are analyzed and improved. Appropriate techniques for soil management, diagnosis of deficiencies or excesses in plant nutrients and fertilizer application are developed. New technologies for evaluation of the quality of ir-

rigation water and for the purification of polluted water are also studied.

2) *Diseases and insect pests*—In the case of diseases and insect pests attacking crops in addition to doves and bulbuls, the cause of occurrence, the mechanism of epidemics and the resistance of crops are studied. Effective measures of forecasting and integrated control related to the important diseases and insect pests are developed.

3) *Weather disasters* — The mechanism of occurrence of crop injury due to abnormal weather is studied and techniques to avoid and alleviate of crop damage are also being developed.

### Farm Mechanization

The improvement and development of various types of agricultural machines and facilities adapted to lowland and upland field operations are being promoted by the aid of recent advances in technology. Emphasis is placed on the development of labor-saving machines and equipment with a high level of safety and with excellent durability.

With a view to the aging of the agricultural work force and the increasing participation of women, the ergonomic characteristics of such work forces are analyzed for developing rationalized farm work techniques adapted to their capacity. Furthermore, studies on the improvement of solar drying facilities, and on techniques for the exploitation of unused resources and for the treatment and utilization of organic matter are being conducted with a view to saving energy and resources.

### Production System

1) *Intensive utilization of cultivated land*—Alternate use of paddy and upland fields for the cultivation of rice and field crops are studied. In placing emphasis on the prevention of damage

caused by repeated cultivation and on the preservation of soil fertility, methods of cultivation to stabilize and increase the yield of major crops and vegetables through crop rotation are developed. Techniques for the cultivation of forage crops for dairy purposes including ensiling processes are also developed. Studies on the ecophysiology of weeds and the development of integrated weed control methods including the use of herbicides are carried out.

2) *Increase of agricultural productivity*—Systematization of techniques for the joint utilization of farm machinery, facilities and lands in regional agriculture in order to reduce the production cost of main crops such as rice, wheat, barley and soybean.

3) A comprehensive information system on farm management is being developed to make available at the regional level the results of studies carried out in various institutes.

### Farm Management

In order to develop agricultural production and economies, it is necessary to allocate resources efficiently and to promote rural welfare. For these purposes, economic and sociological analyses are conducted and studies on the following fields are being undertaken: ① maintenance of the infrastructure, including the preservation of land and water resources, ② farm management and marketing strategies for field crops, vegetables, fruits, livestock, and sericulture, ③ adjustment of land use between full-time farmers and part-time farmers in villages and urban areas, ④ rural activities on a community basis.

### Activities of Dept. of Farm Mechanization

### Paddy Farm Mechanization Laboratory

The main object of activities in this laboratory is to research on the efficient utilizing technology of agricultural machines and facilities for crop production in paddy field.

The current research and development topics in the laboratory are as follows:

1) *Developing the mechatronics steering mechanism of rice transplanter*—The load for operators using the machines increases with increasing the operating speed and accuracy in a large lot of paddy fields.

Therefore, the mechatronics steering mechanism for the rice transplanter is being developed by introducing micro-computers and magnetic direction sensors.

2) *Developing the autonomous farm tractor*—It is expected to reduce the rice production cost with a large scale farming. The expansion of scale will be realized with gathering paddy fields of small lot.

Therefore, the autonomous farm tractor is being developed from the joint research by our laboratory and a company. The tractor is controlled with wireless by a host computer at the control station. An operator will be able to operate simultaneously a number of the tractors.

3) *Developing crop cultivation systems with a gantry*—A gantry system controlled by computer was developed in this center in 1982. The gantry works as a big

XYZ plotter with the high precision in the field. It is free from soil consolidation (Fig. 2)

The crop cultivation system with the gantry is being researched to get high yield and high quality of crops now.

4) *Developing the solar energy drying facilities*—The artificial drying facilities by the solar energy was developed to save oil energy using drying process (Fig. 3). The drying facilities consists of a circulating dryer and a heat collector so-called vinyl-house.

### Upland Farm Mechanization Laboratory

The main object of activities in this laboratory is studying on the efficient utilization of agricultural machines and facilities in upland field cropping.

The current research and development topics in the laboratory are as follows.

1) Developing a no-tillage planter for soybeans cultivated after harvesting wheat in lowland-upland rotated fields. We developed a no-tillage planter by using the frame and chain cases of rotary cultivators. To keep



Fig. 2 Crop cultivation systems with a gantry.

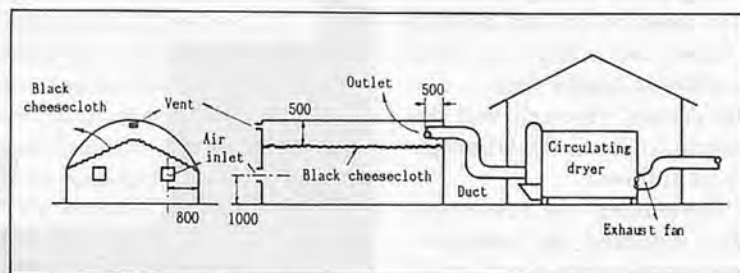

Fig. 3 Artificial drying facilities by the solar energy.

the seedling ratio even under too wet and too dry conditions after seeding, we are improving this machine by adding one rotary cultivating unit to dig a shallow ditch between two cutaway rippled disk openers rotated in the upcut direction, triple disk type seeding mechanism and disk type conveying units.

- 2) Developing a system to dry efficiently soybeans with relatively high moisture contents in vinyl houses.
- 3) Evaluating the controlled traffic system and developing the work system by a wide frame vehicle.
- 4) For the improvement of soil physical properties and the reduction of draft, a soil loosening machine using compressed air (Fig. 4) was developed and is now on market. This machine has an air compressor of maximum pressure 1.0 MPa and can be operated in the work depth 50 cm by tractors of 25 kW.
- 5) A pull out and cutting type combine harvester for soybeans (Fig. 5) was developed and is on market. This machine grasps stems near the roots, pulls out, cuts and threshes them. As a result, the harvesting of soybeans with low moisture contents can be achieved with a little grain losses.

#### Paddy Farm Work Laboratory

The main object of activities in the Paddy Farm Work Laboratory is to research on and develop farm work technology for crop production in paddy field.

The current research and development topics in the laboratory are as follows:

- 1) *Developing the rice transplanter mounted by tractor*—Before transplanting rice, the soil in field must be prepared by till-

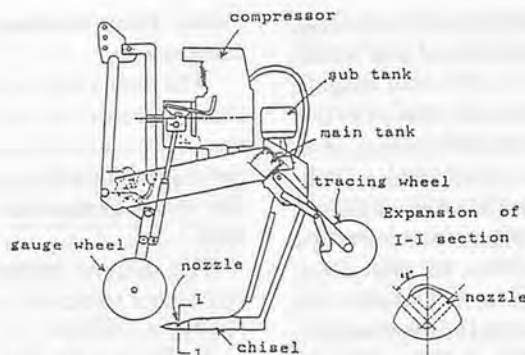

Fig. 4 Side view of soil loosening machine with compressed airblast.



Fig. 5 Pull out and cutting type combine harvester for soybeans.



Fig. 6 Direct Transplanter.

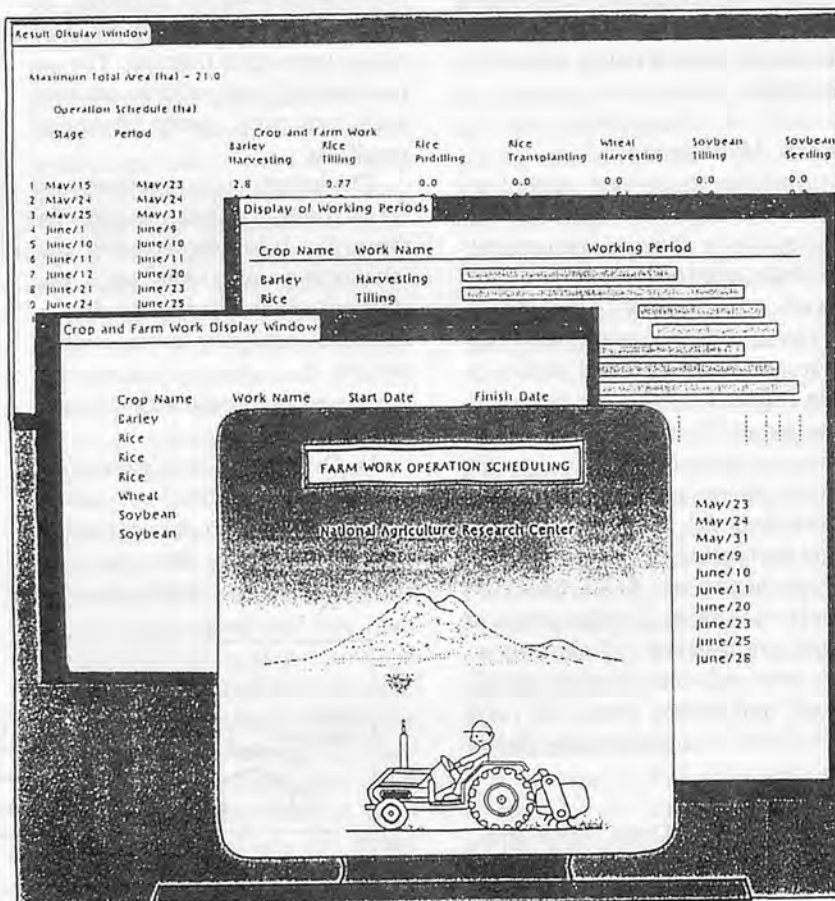

Fig. 7 Farm work scheduling system.

ing and puddling. Since the optimum working period for transplanting is limited severely, transplanting with tilling and puddling becomes the bottle neck work to expand the cultivation area in an attempt to reduce the production cost. The tractor-mounted type transplanter (Fig. 6) developed by the laboratory has the function of direct transplanting without pre-treatment of soil. Therefore, this transplanting technology will be able to be applied to the large scale farming which is expected in Japan.

2) *Determining the operating condition of combine harvester*—The purpose of this research subject is to make clear the optimum operating conditions which must be achieved to keep the quality high at the time of harvesting soybeans and wheat.

3) *Developing the system for optimum scheduling of farm works*—This is the computer aided system to get an optimum farm work schedule as shown in Fig. 7. As an algorithm for optimization in the system, the LP method was used and the object-oriented programming, Smalltalk-80, was applied to compose the system. The result of calculation is given automatically according to the input data on farm working.

#### Upland Farm Work Laboratory

Our main objects are to build comfortable farm work system and next generation plant production systems by using the methods of Biology, Medical-bio electron-



Fig. 8 The plant growth measuring system.

ics, Computer science and so on.

Our current researches are as follows.

1) *Fundamental research for measuring human factors*—This study aims to develop new methods which can measure and evaluate the work load of tractor operator.

2) *Developing the software and hardware for advanced plant production*—The mathematical plant growth models are developed based on theoretical biology, neuro-computing and fuzzy theory. Because many data are indispensable to identify the models, we are developing the automatic growth measuring system (Fig. 8). In the chamber of this system, air temperature, humidity, air pressure, PAR and acoustic, electric and magnetic fields are controlled. And CO<sub>2</sub> absorption, stomata shape and bio-photon emission can be measured.

Our research and development topics are as follows.

1) *Portable energy expenditure measuring apparatus*—This ap-

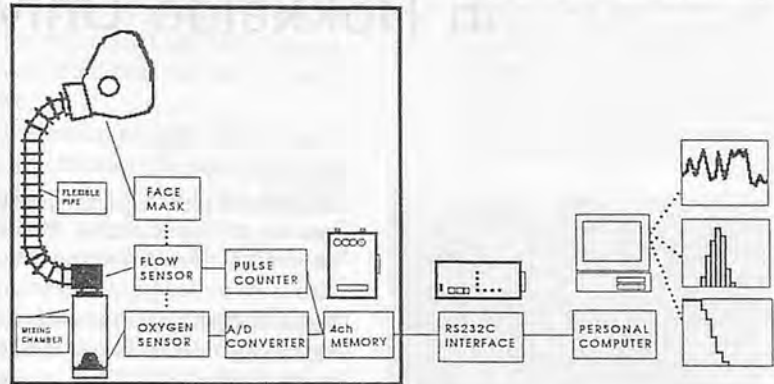

Fig. 9 Portable energy expenditure measuring apparatus.

paratus can measure time sequential working energy expenditure. This apparatus consists of a face mask (with two inspiratory and one expiratory valves), a flexible pipe, a turbine type flow volume sensor, mixing chamber, ceramic type high speed response oxygen sensor and 4ch portable memory (Fig. 9). And the memorized data are analyzed by personal computer. Using this apparatus, we know the operator's time sequential physical work load easily.

2) Some expert systems and software tools for the applications with AI and neural networks were developed. And we evaluated the efficiency of agricultural production in a district. ■■

## Prospect of Agricultural Machinery Course in Hokkaido University

edited by  
Department of Agricultural Engineering,  
Faculty of Agriculture, Hokkaido University  
Kita-ku Kita-9, Nishi-9, Sapporo 060 Japan

### Generals

Hokkaido University is one of the largest National Universities under the jurisdiction of the Ministry of Education, Science and Culture in Japan. It consists of twelve faculties, thirteen graduate schools and many institutions, in which almost 6,500 staff conduct advanced researches in the various disciplines of the science and humanities as well as the undergraduate and graduate education of 12,000 students.

The origin of Faculty of Agriculture can be traced back to Sapporo Agricultural College that was founded in 1874 to promote the colonization and became the mother institution out of which the present Hokkaido University has developed in 1907. It has been contributing to development, research and extension of cold regional agricultural techniques. Our researches have been keeping strong communication with Hokkaido area.

Hokkaido University is situated at Sapporo in Hokkaido where took place the 1972 Olympic Winter Games. Hokkaido, located between 41°21' and 45°33' N latitude, is the northernmost is-

land of Japan. It is recognized the biggest farm lands in our country. Paddy fields (260,000ha), up-land fields (420,00ha) and grass lands (470,000ha) are cultivated by 100,000 farmers with the highly mechanized system. They have 25% of Japanese farm lands and 8.5% of national crop production.

### Agricultural Machinery Course

The Faculty of Agriculture comprises eight departments and three institutes. The Department of Agricultural Engineering has two courses, namely, Land Improvements course and Agricultural Machinery course. The former course consists of three laboratories: land improvement, agricultural physics and soil amelioration. The latter also consists of three laboratories for agricultural machinery, agricultural prime mover and agricultural process engineering as described below. Each course has 20 undergraduate students for each grade. The graduate school of Agriculture offers programs of study and research leading to two degrees, the Master of Agriculture and the

Doctor of Agriculture.

Agricultural Machinery course is equipped with modern research instrumentation facilities and also has special indoor laboratory in which 600 m<sup>2</sup> soil bin facilities, 200 m<sup>2</sup> OECD traction test course and one hectare experimental field. These facilities are available for our students.

Our faculties and current research activities are as follows:

### Laboratories and Faculties

*Agricultural Machinery Laboratory*—Our laboratory are concerned with the problems about soil, plant, practices in a farm field. We are working for the agricultural production system, control and developing of farm equipments and implements, plant-soil-tool interaction and evaluation of the effect farm practices on field environment.

Professor:

Satoru Nambu, Dr. Agr.

Associate Professor:

Munehiro Takai, Dr. Agr.

Assistant Professor:

Shun-ichi Hata, Dr. Agr.

Assistant Professor:

Kenshi Sakai, Dr. Agr.

*Agricultural Prime Mover Laboratory*—Our major emphasis areas includes Application of Engine for Farm Use, Tractor Engineering, Construction Machinery Engineering and Terramechanics.

Professor:

Hideo Terao, Dr. Agr.

Associate Professor:

Kazuhiko Ohomiya, Dr. Agr.

Assistant Professor:

Noboru Noguchi, Dr. Agr.

*Agricultural Process Engineering Laboratory*—Our laboratory are concerned with the post harvest technology such as grading, conditioning, processing, drying, storage for agricultural products, and managing agricultural and livestock wastes.

Professor:

Kazuhiko Itoh, Dr. Agr.

Associate Professor:

Juzo Matsuda, Dr. Agr.

Assistant Professor:

Shuso Kawamura, Dr. Agr.

Assistant Professor:

Jun-ichi Himoto, Ms. Agr.

## Current Research Activities

### *Agricultural Machinery*

Soil path on moldboard plow is analyzed for optimal plow design.

Non-linear dynamics in agricultural machines was investigated to prevent violent vibration of tractor-implement system.

Image-processing plant identification technique was applied to weeder or thinner.

Fully automatic control of farm implements with micro-computer was developed for boom sprayer, for driver-less tractor using CCD row detector.

Unique grain harvester was developed using interrupted air blowing system.

Farm management system design was investigated for safety practice and low cost farming.

### *Agricultural Prime Mover*

Alcohol fumigation in diesel engine for farm use to improve the performance characteristics of a diesel engine using fumigated alcohol to fuel a diesel engine.

Dynamic behavior of tractor trailer combination to improve the stability of a tractor-trailer combination, especially the braking performance and steering stability.

Mechanics of traction, to evaluate the effects of the tire type, a conventional bias tire and a radial tire.

Evaluation of farm field roughness to evaluate the roughness of terrain as sources of the tractor vibration.

Soil compaction by traffic to evaluate soil compaction by measuring the corn index and displaying the distribution maps or graphs.

### *Agricultural Process Engineering*

Low pressure storage and storage with annexed function films for vegetables and fruits.

Optimal milling method for the compass rice milling unit as well as the optimal brown rice temperature and moisture content.

Heating characteristics of far-infrared radiation. Drying characteristics on agricultural products with far infrared rays.

Application of near-infrared reflectance spectroscopy on small grain, fruit and vegetables for grading.

The relationship between mechanical properties under applied forces of foods and sensory test for texture.

The effects of fixed films of a digester and solid-liquid separation of livestock wastes for Biogas production.

Composting with aerated pille method and heat extraction from the composting pile.

Huge ice block making by introducing outdoor air in a warehouse for storage of agricultural products.



Fig. 1 Developed 4-shank type vibrating subsoiler—Each shanks were oscillated by PTO shaft in optimal arrangement. Amplitude and frequency were set at 50mm and 3 Hz. As the draft was reduced to the 50%, a medium size tractor was able to do the subsoiling practice at a high efficiency.



Fig. 2 Combination of tractor and trailer—This trailer was developed for investigating the stability of a tractor-trailer combination. The trailer was equipped with a steering system and it was controlled by a computer.

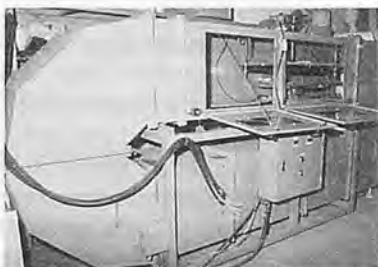

Fig. 3 Far-Infrared Dryer—This dryer is used for measuring the drying characteristics on agricultural products with far-infrared rays.

Sterilization on bean sprouts and cut vegetables with ozonic water for temporary storage.

## Extension of results

### *Agricultural Machinery*

During our long research activities, our results have been applied to design for a lot of implement (from tillage to harvesting) and field practice management. Re-

cently, we introduced and developed the computer control technology to our local industries.

#### *Agricultural Prime Mover*

Results of our farm engine project indicated that alcohol fumigation in diesel engine for farm use makes thermal efficiency higher. We proposed a criterion for the roughness of meadows. We also proposed a braking system and a steering control system for farm trailers to take safety measures of tractor-trailer system.

#### *Agricultural Process Engineering*

Our results have been applied to design and management for post harvesting system. Recently we investigated new technology for detecting qualities of crops by NIR. Drying with tempering method and double stage drying method for small grain was established and extended. The aerated pile composting method for sterilization of the soil separated from root crops is using at many farms.

### **International Cooperation**

Our University has a sister relationship between Portland State Univ., Massachusetts State Univ., Cornell Univ., Alaska State Univ., Wisconsin Univ., Munich Univ. and Beijing Institute of Technology.

Cooperative research is undertaken between Agricultural Process Engineering Laboratory and Province government of Heilung Chaing in China. Main program of this research is investigation of food industry (rice milling plants and so on) in the rural area of the province.

We have tried to keep international relationship using several exchange programs to visit foreign Universities for sabbatic and to invite foreign researchers. In these ten years, 7 Chinese, 1 Russian and 1 Indonesian scholars visited to research for more than several months. A lot of short term visitors are welcomed to communicate and exchange technical information.

### **Foreign Student**

Foreign students accepted by our university are divided into two categories, Japanese Government Scholarship Student and Non-Japanese Government Scholarship Student. The latter category includes not only student on their own funds, but also those who receive financial aid from their governments or organization connected with their government. Beside those on the Japanese Government scholarship, student of foreign nationality may be allowed in academic programs by special admission procedures different from those for Japanese student, if they have sufficient qualifications and if they are available space and opportunities in the faculty or graduate school chosen.

In these ten years, 6 (5 Chinese, 1 Korea) foreign students graduated Ph.D course and 3 (1 Thailand, 2 Chinese) students graduated M.s. course and one Chinese students graduated B.s. course. ■■

## Is your Agricultural Machinery Industry faced with problems of development and growth?

We can provide you with know-how to help your company and industry develop and grow.

#### **Specific Information Service.**

Statistics, Product Information, Patents, Test & Research Data, References and Directory.

#### **Survey & Research.**

Marketing Research, Forecasting on Economic, Technical, Supply, Demand, etc. and Dealer Search.

#### **Consultation.**

Policy Making, Management Improvement, New Development of Organizations, Motivation.

#### **Publication Activities.**

Basic, Production and Sales Statistics for Agricultural Machinery, etc.

### **FARM MACHINERY INDUSTRIAL RESEARCH CORP.**

7-2 Kanda Nishikicho, Chiyoda-ku, Tokyo, Japan (Tel. 03/291-5717-8, 3671-4)



## Research and Education of The University of Tsukuba



by  
Toshio Konaka  
Professor and Chairman  
Institute of Agricultural Engineering  
The University of Tsukuba  
1-1-1, Tennodai, Tsukuba 305

The University of Tsukuba is located 60km North of Tokyo. The Research Institute of Agricultural and Forest Engineering, one of the Institute of the University of Tsukuba, was established in October, 1973. The Institute succeeds the Department of Agricultural Engineering which belonged to the Faculty of Agriculture, Tokyo University of Education established in 1937.

### Research Fields

The research fields covered by the Research Institute of Agricultural and Forest Engineering consist of farm and forest engineering, agricultural machinery and facilities, and wood products engineering. Comprehensive research activities are being conducted, and the Institute places emphasis on the promotion of international research cooperation.

#### Farm and Forest Engineering

- i) Agricultural Land Engineering
- ii) Irrigation and Drainage
- iii) Forest Utilization
- iv) Erosion Control

#### v) Watershed Management

#### Agricultural Machinery and Facilities

##### i) Agricultural Machinery

Many kinds of farm machinery and equipment are effectively used for agricultural production around the world. Research and development of farm machinery, especially on tillage and soil compaction mechanics, direct rice seeding and lawn culture, are conducted with advanced technology such as microcomputer graphics, etc. Also, systems engineering techniques such as simulation, A.I., expert systems, etc., are applied to farm mechanization planning using personal computer for farm operation schedule and management.

##### ii) Agricultural Process Engineering

Agricultural process engineering refers to the application of basic engineering and biological principles to the design, development and improvement of processes that employ agricultural products. Research activities in this field are concerned with rheology and physical properties of

agricultural and related materials, heat and mass transfer involved in agricultural processing, measuring and controlling dust from grain handling, determining the degree of milling of rice, and methane reactor design.

##### iii) Farm Structures

Modification of the climatic environment is the primary function for most agricultural buildings. This means that some level of environment control is necessary for livestock and poultry production, plant growth during certain seasons, storage of agricultural products, machinery and equipment protection, etc. Research projects currently being conducted aim at studying the measures and systems environmental control for various agricultural buildings on the basis of the data obtained from experiments and field surveys.

#### Wood Products Engineering

- i) Wood Technology
- ii) Chemistry of Forest Products

Faculty and Staff Member	
Professor	7
Associate Professor	10
Assistant Professor	5
Research Associate	5
Technical Staff	7
Total	34

## Education

The Faculty provides a curriculum for those students interested in biological resources development offered by the College of Agriculture & Forestry, in soil & water conservation under the Master's Degree Program in Environment Sciences, and in agricultural and forest engineering under the Doctoral Program in Agricultural Sciences.

### Undergraduate Curriculum

The curriculum in biological resources development major leading to the degree of Bachelor of Science (Nougaku-shi) is:

- Introduction to Biological Resources Development
- Introduction to Agricultural Engineering
- Forest and Forest Products Engineering
- Systems Engineering Agriculture
- Engineering Mathematics
- Introductory Fluid Engineering
- Soil Physics
- Computer Programming in Agricultural and Forest Engineering
- Laboratory in Agricultural and Forest Engineering
- Agricultural Land Engineering

- Soil Mechanics
- Agricultural Hydrotechnics
- Agricultural Machinery
- Design and Seminar in Agricultural Machinery
- Laboratory in Agricultural Machinery
- Agricultural Power and Machinery
- Agricultural Process Engineering
- Design and Seminar in Agricultural Process Engineering
- Laboratory in Agricultural Process Engineering
- Introductory Power Technology
- Agricultural Structures
- Design and Seminar in Agricultural Structures
- Laboratory in Agricultural Structures
- Environmental Engineering in Agriculture
- Strength of Materials
- Introductory Mechatronics
- Food and Renewable Energy Resources
- Work Study in Farming
- Machine Shop Practice
- Farm Machinery Practice
- Timber Harvesting and Machinery
- Erosion Control Engineering
- Wood Technology

### Graduate Curriculum

The curriculum in agricultural and forest engineering major leading to the Doctor of Philosophy (Nougaku-hakushi) is:

- Advanced Agricultural Machinery
- Advanced Agricultural Power and Land Locomotion
- Seminar in Agricultural Machinery
- Research in Agricultural

- Machinery
- Advanced Farm Structures
- Seminar in Farm Structures
- Research in Farm Structures
- Advanced Agricultural Process Engineering
- Advanced Processing Equipment for Agricultural Products
- Seminar in Agricultural Process Engineering
- Research in Agricultural Process Engineering

Note: All lecture and seminar are provided in Japanese.

## Foreign Student Enrollment

Total foreign student at University of Tsukuba is over 700 at present. 25 foreign students, 11 from China, each 2 from Korea, Philippine, Thailand, Taiwan, Malaysia, each 1 from Hongkong, Indonesia, Nigeria, Brazil, have been enrolled in our Master or Doctor Course.

It is preferable that everybody who want to enroll to our university, make sure to obtain the scholarship from own government or company or from Monbusho of Japanese Government before submitting application form to University of Tsukuba.

The application form and guidebook are obtained by contacting directly to the Section for Foreign Students of the Division of International Relations, University of Tsukuba.  
Address: 1-1-1, Tennodai, Tsukuba, Ibaraki, 305 JAPAN.  
Phone: 0298-53-2237 ■■

# Introduction of Agricultural Machinery Laboratory Department of Agricultural Engineering Kyushu University



by  
Jun Sakai  
Professor  
Department of Agricultural Engineering  
Faculty of Agriculture, Kyushu University  
6-10-1, Hakozaki, Higashi-ku  
Fukuoka 812, Japan

## Introduction of the Faculty of Agriculture

Japan started to establish European and American higher education systems about one hundred years ago, and seven imperial universities were orderly established one by one at the interval of about ten years all over the country: in Tokyo in 1886, in Kyoto in 1897, in Tohoku in 1907, in Kyushu in 1911, in Hokkaido in 1918, in Osaka in 1931 and in Nagoya in 1939.

Namely, the Kyushu University was founded in January, 1911 originally as Kyushu Imperial University. The College of Engineering and the College of Medicine in the University were established in January and April

---

The author hopes that this report may give better understand of Agricultural Machinery Laboratory, Kyushu University and Japan's education system.

in the same year. In February, 1919, these two colleges took the form of the Faculty of Medicine and the Faculty of Engineering, and in the same year the Faculty of Agriculture was added to the University. Since 1924, several faculties such as the Faculty of Law, the Faculty of Literature, the Faculty of Economics and the Faculty of Science were orderly established to make the university of seven highest institutions of learning in Japan at that time.

The colleges of agriculture in the imperial university were also orderly established. First, the College of Agriculture was set up in the Imperial University of Tokyo in 1890, and next in Hokkaido Imperial University in 1918, and in Kyushu Imperial University in 1919, and also in Kyoto Imperial University in 1923 and so forth.

In 1947 after World War II, all imperial universities changed their

names to only University without the word "Imperial" under the new educational renovation. Thus, Kyushu Imperial University changed its name to Kyushu University. At the same time, all prefectures in Japan started to organize and establish at least more than one national university, and nowadays in 1985, Japan has about ninety-five national universities. Among them, more than forty national universities have the Faculty of Agriculture and about thirty national universities have the Department of Agricultural Engineering in the college. Namely, the Faculty of Agriculture, Kyushu University, is the third oldest one among faculties of agriculture in more than forty national university of Japan.

When the Faculty of Agriculture was established in Kyushu University, in 1919, the Agricultural Engineering Laboratory was

established in the Department of Agronomy, and in 1923, the Special Course of Agricultural Engineering was established. Then, in 1941, the Agricultural Machinery Laboratory was set and the Department of Agricultural Engineering was established with the Laboratory of Irrigation, Drainage and Land Reclamation Engineering in Kyushu University.

The Faculty of Agriculture in 1990 has 54 professors, 59 associate professors, 65 assistant professors and 59 administrative and assisting staffs. The enrollment now reaches 1,405, including about 297 graduate students and 60 foreign students. To date, the Faculty has awarded 10,502 academic degrees in agricultural science: 8,258 degrees at the bachelor's level, 1,765 degrees at the master's level and 2,131 doctorates during the last 71 years.

### Master's and Doctor's Degree Education

All imperial university in Japan were originally established in order to fulfill research and education functions for the Doctor's degree. Thus, Kyushu University Graduate School has ten Divisions nowadays for Master's and Doctor's degree education based on ten Bachelor education. They are the Divisions based on the Faculties of Literature, Education, Law, Economics, Science, Pharmaceutical Science, Engineering, Agriculture, Medical Science and Dental Science. The Interdisciplinary Graduate School of Engineering Science also offers a program leading to the Doctor's degree, independently of the Divisions mentioned above.

The period of attendance needed for the completion of the Doctor's program is generally 5 years with the exception of the 4-year program offered by the Divisions

of Medical Science and Dental Science. Those students who leave the Graduate School on completing the first 2 years may be granted the Master's degree.

Those who may apply for admission to the M.S. Course of the Graduate School are required to have one of the following qualifications:

- a) Graduation from college or university as stipulated under Article 52 of the School Education Law in Japan.
- b) Completion of the 16-year course of school education in a foreign country.
- c) Designation by the Minister of Education, Science and Culture.
- d) The Graduate School's recognition as equal or superior to a).

Those who may apply for the admission to the Doctor's Course (the latter 3-year course) of the Graduate School are required to have the Master's degree or scholastic achievement equal or superior to that of the Master's degree holders.

Those who apply for admission into the Graduate School are required to pay the examination fee of 22,000 yen (about \$160). Every applicant has to take an entrance examination for his or her major field, two foreign languages and oral examination. The system and date of the entrance examination varies slightly depending upon the faculty. In the case of the Faculty of Agriculture, two foreign languages mean Japanese and another language except his or her mother language.

Those who are granted admission should pay the matriculation fee of 206,000 yen (about \$1,500) at the time of entrance. The tuition fee is 339,000 yen (about \$2,500) a year.

This degree education system is called the "Course Doctor System". In the Division of Agricul-

ture, Graduate School, Kyushu University, the student who studied and had excellent research activity in the course at least more than 2.5 years after M.S. degree study will be qualified for starting to write his Doctor thesis and submission. The most part of the thesis is required to have been published in or approved for publication by the referee of academic society journals or equivalents in the form of at least four academic reports. The doctorate degree by this system will be given to the thesis author who can be expected to achieve effective research by himself in the future.

Kyushu University also has the "Thesis Doctor System". The doctorate degree by this system will be given to the thesis author who achieved sufficiently scientific contributions to the progress of the academic society. This system requires the candidate, for example in actual cases, to have more or less twenty research papers in the academic society journals or equivalents. In this case, a competent professor may advice him to submit the thesis consisting of his several academic papers on the same research subject published in the journal.

This system in the Faculty of Agriculture, Kyushu University, requests to the foreign candidate to spend more than one year as a visiting researcher to the professor in Kyushu University.

### Agricultural Machinery Laboratory

Agricultural Machinery Laboratory, Kyushu University, is one of following seven laboratories in the Department of Agricultural Engineering:

- 1) Irrigation and Water Utilization (1992 -); Prof. Masaharu Kuroda
- 2) Drainage and Reclamation



Fig. A tractor field test of tillage performance.

- (1923 ~): Prof. Yoshio Tohara
- 3) Agricultural Meteorology (1941 ~): Prof. is vacant.
  - 4) Land Improvement and Conservation (1964): Prof. Masateru Takayama
  - 5) Agricultural Machinery (1941 ~): Prof. Jun Sakai
  - 6) Agricultural Process Engineering (1965 ~): Prof. Satoshi Murata
  - 7) Mechanics, for Bio-Production (1989 ~): Prof. Koichi Hashiguchi

These laboratories are divided into two courses. One is the Irrigation, Drainage and Land Reclamation Course consists of four laboratories of 1), 2), 3) and 4) for 25 undergraduate students every year, and the other is Agricultural Machinery Course consists of two laboratory of 7) is newly established and acceptable three undergraduate students every year from both courses.

The laboratory consists of, as a rule, one professor, one associate professor, two assistant professors and a few assistants, except the laboratory 7) managed by one professor only. So that, the total number of formal teaching staffs in the department is 7 professors, 6 associate professors and 12 assistant professors.

The Agricultural Machinery Laboratory was established in Dec. 13, 1941, and the first professor was Dr. Shuroku MORI (1941 ~ 1978). and the third is at present one. The total number of senior students every year is 7 to 8 students for the undergraduate

course and two students every year for masteral course. For example, In 1991, four students in Doctor Course, and four students in Master Course are studying. Total number of foreign students in graduate course in 1991 is two in Doctor Course and one in Master Course.

Present staffs are:

Professor: Dr. Jun Sakai (1979 ~)

Assoc. Prof.: vacant (Dr. Koichi Hashiguchi, 1981 ~ 1989)

Assist. Prof.: Dr. Eiji Inoue, (1986 ~)

Research Assoc.: Mr. Shoichiro Yamanaka (1981 ~)

Technician: Mr. Katsumi Tashiro (1968 ~)

This laboratory relates to the fields of farm power and field equipments such as natural energy resources, farm engines, tractors and many field equipments from primary tillage machinery to harvesting machinery.

The activities of the laboratory to society would be understood through the record of academic papers and theses. These in recent years were as follows:

#### Main Academic Papers (1988 ~ 1990)

Sakai, Zou: Studies on Feedback Power and Power Transmission Systems of Closed-loop for Rotary-tilling Tractors (Part 4), JSAM Journal, 50 (1), 19 ~ 26, Jan. 1988

Hashiguchi, Kamei, Hiroma, Sakai, Ide, Imamura: A Traveling Performance of Rigid Lugged Wheels (Part 1), JSAM Journal, 50 (1), 27 ~ 36, Jan. 1988

Surin, Sakai, Kishimoto: A Study on Engineering Design Theories of Hand Tractor Plows (II), AMA, 19(2), 9 ~ 19, April 1988

Sakai, Chen, Yamanaka, Noguchi: Performance Estimation

of a Rotary Axles for the Expert System, Journal of JSAM Kyushu Branch, 37, 1-7, Sept. 1988.

Sakai, Kishimoto, Surin: Basic Studies on Design Theories of Agricultural Wheels (Part 1), —Lug Elements and Motion Analyses of Wheels—JSAM Journal, 50 (6), 11 ~ 18, Dec. 1988

Sakai, Kishimoto, Inoue, Surin: Studies on Design Theories of Agricultural Wheels, —Motion Analysis with Lift Reduction and Lug Design—Proceedings of ISTVRO, AIT, Bangkok, Dec. 1988.

Inoue, Sakai, Hashiguchi, Matsuo: Driving Characteristics of Rubber Crawler for Farm Machinery, Proceedings of ISTVRO, AIT, Bangkok, Dec. 1988

Sakai, Zou, Nakaji: Studies on Optimal Control of Farm Power-Transmission-Equipment Systems (Part 1), JSAM Journal, 51 (1), 13 ~ 20, Jan. 1989

Sakurai, Sakai,: A Study on the Mathematical Model of Japanese Rotary Blades for CAD, (Part 1), JSAM Journal, 51 (1), 29 ~ 35, Jan. 1989

Zou, Sakai, Nakaji: Studies on Optimal Control of Farm Power-Transmission-Equipment Systems (Part 2), JSAM Journal, 51 (2), 9 ~ 16, Mar. 1989

Sakai, Zou, Inoue: Basic Studies on the Power Driven Disk Plow (Part 1), JSAM Journal, 51 (2), 39 ~ 45, Mar. 1989

Sakai, Matsuo, Inoue: Studies on Motion Characteristics and Design Theories of the Rubber Crawlers for a Combine Harvester (Part 1), JSAM Journal, 51 (3), 41 ~ 48, May 1989

Sakai, Matsuo, Inoue: Studies on Motion Characteristics and Design Theories of the Rubber Crawlers for a Combine Har-

- vester (Part 1), JSAM Journal, 51 (3), 41 ~ 48, May 1989
- Zou, Sakai, Nakaji, Liu: Studies on Optimal Control of Farm Power- Transmission-Equipment (Part 3), JSAM Journal, 51 (5), 3 ~ 10, Sept. 1989
- Kwon, Sakai; Inoue, Umeda: A study on Tillage Characteristics of Power Driven Disk Plow, Journal of JSAM Kyushu Branch, 38, 1 ~ 5, Sept. 1989
- Sakai, Chen, Noguchi: Making an Expert CAD System of a Rotary Tilling Shaft by the Expert Shell, Journal of JSAM Kyushu Branch, 38, 6 ~ 11, Sept. 1989
- Sakai, Liu, Nakaji: PTO Performance of Small Riding Tractors and Fuel Delivery Adjusting Apparatus, Journal of JSAM Kyushu Branch, 38, 12 ~ 17, Sept. 1989
- Sakai, Nakaji, Liu: PTO Performance Analysis on Small Riding Tractors AMA, 20 (4), 9 ~ 14, Oct. 1989
- Sakai, Liu, Nakaji, Zou: Studies on Optimal Control of Farm Power- Transmission-Equipment system (Part 4), JSAM Journal, 52 (1), 3 ~ 10, Jan. 1990
- Sakai, Chen, Yamanaka: Studies on Optimum Design Theories of Rotary Shaft and the Expert CAD System (Part 1), JSAM Journal, 52 (2), 19 ~ 26, Mar. 1990
- Inoue, Sakai, Inaba: Basic Studies on Vibration Characteristics of the Rubber Crawler System for Farm Machinery (Part 1), JSAM Journal, 52 (2), 27 ~ 34, 1990
- Mizota, Noguchi, Chen, Sakai, Nakajima, Morizono: A Combination of Conversation Type Computer Programming Language for Beginners (BASIC) and Personal CAD System, Res. Bull. Fukuoka Institute of Technology, 22 (2), 203 ~ 201, Mar. 1990
- Chen, Sakai, Mizota, Noguchi: Study on Expert CAD System for Decision Making in Optimum Design, Sci. Bull. Fac. Agr., Kyushu Univ., 44 (4), 143 ~ 146, Mar. 1990
- Sakai, Kwon, Inoue: Basic Studies on the Power Driven Disk Plow (Part 2) JSAM Journal, 52 (3), 21 ~ 28, May 1990
- Kishimoto, Inoue, Sakai, Matsuo: Basic Studies on Design Theories of Agricultural Wheels (Part 2), JSAM Journal, 52 (4), 11 ~ 19, July 1990
- Inoue, Sakai, Inaba: Basic Studies on Vibration Characteristics of the Rubber Crawler for Farm Machinery (Part 2), JSAM Journal, 52 (4), 26 ~ 36, July 1990
- Sakai, Chen, Yamanaka: Studies on Optimum Design Theories of a Rotary Shaft and the Expert CAD System (Part 2), JSAM Journal 52 (4), 45 ~ 52, July 1990
- Kwon, Sakai, Inoue: Basic Studies on the Power Driven Disk Plow (Part 3), JSAM Journal, 52 (4), 53 ~ 60, July 1990
- Sakai, Mizota, Chen, Noguchi: Development of Expert CAD System for Tractor Tillage Mechanisms, Proceedings of Int. Conf. Machine Design, Vol. 1, 313 ~ 322, Dubrovnik, Yugoslavia, Aug. 1990
- Inoue, Sakai, Inaba: Basic Studies on Vibration Characteristics of the Rubber Crawler System for Farm Machinery (Part 3), JSAM Journal, 52 (5), 11 ~ 18, Sept. 1990
- Sakai, Zhou, Inoue, Chen: An Equipment for Measuring Forces Acting on the Agricultural Wheel Lug, Journal of JSAM Kyushu Branch, 39, 6 ~ 10, Sept. 1990
- Sakai, Liu, Inoue: Computer Aided Instruction System for Measurement and Control (Part 1), Journal of JSAM Kyushu Branch, 39, 11 ~ 16, Sept. 1990
- Sakai: Principles of Walking Tractor Plowing and Design Theories of Japanese Plows, Journal of JSAM Kyushu Branch, 39, 38 ~ 46, Sept. 1990
- Sakai, Liu, Nakaji, Kim: Studies on the Optimizing Control of Tractor Engine Performance (Part 1), JSAM Journal 52 (6), 3 ~ 10, Nov. 1990
- Inoue, Sakai, Inaba: Basic Studies on Vibration Characteristics of Rubber Crawler System for Farm Machinery (Part 4), JSAM Journal, 52 (6), 19 ~ 26, Nov. 1990
- Sakai, Matsuo, Inoue, Inaba: Research on the Lug Motion Characteristics of the Agricultural Rubber Crawler, Proceedings of Int. Agric. Engg. Conf. and Exhi., Vol. 1, 259 ~ 268, AIT, Bangkok, Dec. 1990
- Ikemi, Sakai: The Three-Point Hitching System of a Rotary Tilling Tractor for Paddy Cultivation, Proceedings, of Int. Agric. Engg. Conf. and Exhi., Vol. 1, 277 ~ 286, AIT, Bangkok, Dec. 1990

#### Master Education and Thesis Subjects (1988 ~ 1990)

The Agricultural Machinery Laboratory awarded Master Degree to the following 6 graduates including one foreign student of the Master Course during the last 3 years.

Mr. Takeshi IMAMURA (1988): A study on the Traveling Performance of Lugged Wheels on Soils. He is now an R&D Design Engineer, Tractor Design Section, KUBOTA Co., Ltd., Osaka, Japan.

Shigeki INABA (1989): A study on the Vibration Characteristics of the Rubber Crawler System for Farm Machinery. He is now an Assistant Professor, Agricultural Machinery Laboratory, Saga University, Saga, Japan

Shiro Tsuno (1989): A Study on the Walking Tractor and Plowing. He is now an R&D Design Engineer, Tractor Design Section KUBOTA Co., Ltd., Osaka, Japan

Takesi SHIKANAI (1990): Experimental and Theoretical Studies on the Traveling Performance of Wheels. He is an R&D Design Engineer, YANMAR Diesel Co., Ltd., Kyoto, Japan

Weizhong ZHOU (1990): A Study on an Measurement of External Forces Acting on Lugged Wheels. She was a Chinese student from Jiangsu Institute of Technology, Zhenjiang, China. Now, she has a baby born on the 27th December, 1990, in Japan. Her husband is Dr. Peng CHEN listed in the following section in this report.

Ryozo NOGUCHI (1990): Development of an Expert CAD System for Tractor Tillage Mechanisms. He is a student, Doctor Course, Kyushu University, Fukuoka, Japan.

#### **Doctor Education and Thesis Subjects (1988 ~ 1990)**

The Agricultural Machinery Laboratory Awarded Doctor Degree to the following 11 scholars:

Surin PHONGSUPASAMIT (March 1988, Course Doctor): Basic Research on Walking Tractor Plows and Their Engineering Design Theories. He was a Thai student after graduating from AIT. He is an Associate Professor, Mechanical Engineering Department, Chulalongkorn University, Bangkok, Thailand. He obtained National Invention

Prize for plow in 1990.

Takaaki MTASUO (June 1988, Thesis Doctor): Study on the Design Theories of the Rubber Crawler Lugs and Trafficability for a Combine Harvester. He is an Associate Professor, Agricultural Machinery Laboratory, Saga University, Saga, Japan.

Cheng ZOU (Sept. 1988, Course Doctor): Study on the Power Transmission Characteristics and Optimal Control in Farm Machinery. He was a Chinese student from West North University of Agriculture, Sieang, China. Now he is an Associate Professor, Beijing Agricultural Engineering University, Beijing, China.

Tatsuo HIROMA (Nov. 1988, Thesis Doctor): Basic Studies of Mutual Operations Between Tractor Wheels and Soils. He is an Associate Professor, Department of Agricultural Machinery, Iwate University, Morioka, Japan.

Toshitaka UTINO (March 1989, Thesis Doctor): Application Systems of Static Electricity to Agricultural Pest Control. He is an Assistant Professor, Horticulture Machinery Laboratory, Chiba University, Matsudo, Japan.

Sang Woo LEE (April 1989, Thesis Doctor): Studies on the Atomizing Mechanism for the Sprayer Nozzle. He is a Professor, College of Agriculture, Chungnam National University, Taejon, Korea.

Ken KAWASAKI (Oct. 1989, Thesis Doctor): Research of the Development of Energy Conversion Facilities for Small Hydraulic Power to Agricul-

ture. He is Chief Research Engineer, Agriculture Research Center, Ministry of Agriculture, Forestry and Fishery, Japan.

Eiji INOUE (Dec. 1989, Thesis Doctor): Basic Study on the Vibration Characteristics of the Rubber Crawler System for Farm Machinery. He is an Assistant Professor, Agricultural Machinery Laboratory, Kyushu University, Fukuoka, Japan.

Soon Goo KWON (March, 1990, Course Doctor): A Study on the Design Theories of the Power Driven Disk Plow for the Tractor. He is working in Agricultural Mechanization Institute, Rural Development Administration, Suweon, Korea.

Peng CHEN (July 1990, Course Doctor): A Study on the Optimum Design Theories of the Tractor Rotary Tillage Mechanism by Knowledge & Information Engineering. He was a Chinese student from Jiangsu Institute of Technology, Zhenjiang, China. Now he is an Assistant Professor, Department of Mechanical System Engineering, Kyushu Institute of Technology, Iizuka, Japan. He is expected to go back to China in March 1992.

Jiao Long LIU (Oct. 1990, Course Doctor): Tractor Engine Performance and its Optimization Through Computer-Based Control of the Power Train. He was a Chinese student from Jilin University of Technology, Cahngchun, China. He is working in R&D Center, ASAHI Electronics Co., Ltd., Kitakyushu, Japan. He is expected to go back to China in March 1992. ■■

# Introduction of Japanese Society of Agricultural Machinery



by  
Toshio Konaka  
Director of International Exchange  
Japanese Society of Agricultural Machinery  
c/o BRAIN, 40-2, 1-chome, Nisshin-cho,  
Omiya, Saitama, 331 Japan

Japanese Society of Agricultural Machinery (JSAM-Nogyo-kikai Gakkai) was founded on April 4, 1937, at the University of Tokyo.

Successive Presidents are as follows:

First	President 1937- Hirobe, Tatsuzo
Second	President 1947- Nihei, Teiichi
Third	President 1963- Shoji, Fusanobu
Fourth	President 1968- Kaburagi, Hideo
Fifth	President 1971- Yasuda, Yoshichiro
Sixth	President 1974- Matsuda, Ryoichi
Seventh	President 1980- Hosokawa, Akira
Eighth	President 1983- Kawamura, Noboru
Ninth	President 1986- Yamashita, Ritsuya

#### Member of Board 1989-1981

President	Yamashita, Ritsuya
Director of General Affairs	Namikawa, Kiyoshi
Director of Finance	Kitani, Osamu
Director of Editorial Affairs	

Miura, Kyoshiro  
Director of International Exchange

Konaka, Toshio  
Director of Hokkaido region  
Nambu, Satoru

Director of Tohoku region  
Shimizu, Hiroshi

Director of Kanto region  
Ai, Fusakazu

Director of Kansai region  
Namikawa, Kiyoshi

Director of Kyushu region  
Furuchi, Hisao

Director  
Ashizawa, Toshiaki: Itatani,  
Hiroshi: Kuwana, Takashi:  
Morishima, Hiroshi: Murata,  
Satoshi: Sakai, Jun: Takeda,  
Tsutomu: Umeda, Shigeo:  
Yonemura, Junichi

Auditor Hayasi, Naotaka:  
Kobayashi, Tadashi  
Councilor (100 persons)

#### Number of the Members and member fees per year

Honorary member	11	None
Regular member (domestic)	1377	¥ 7000
Regular member (overseas)	51	¥ 7000
Student member	9	¥ 4000

Special member	68	¥50000*
Subscribing member	137	¥ 9000
Total	1653	

Note \* minimum unit fee

#### Activities

##### Annual Meeting

1991	April, 2-5 at Kyoto University
1990	Miyazaki University
1989	Utsunomiya University
1988	Hokkaido University
1987	University of Tokyo
1986	Shimane University
1985	University of Tsukuba

##### Award

- 1) Academic Award
  - 1990 Hashiguchi, Koichi [Soil dynamics of field machinery]
  - 1989-1980 Miura K., Oida A., Kato H., Iwao T., Kawana S., Ito N.,
  - 1979-1970
  - Abe T., Namikawa K., Naka S., Kitani O., Ban T., Tojo M., Ai F., Mori K., Konaka T., Okamura T., Murata S.
  - 1969-1960



Tanabe H., Nakagawa K., Takenaga T., Yoshida T., Aramaki T., Yamazawa S., Miyakita K., Endo S., Sakai J., Nakamura C., Wakui M., Ishihara T., Ishibashi S., Matsuo M., Tanaka T., Umeda S., Takeuchi R., Kano H., Tsuchiya M., Shimizu H., 1959-1954

Imai M., Chuma Y., Tawara T., Sonomura M., Niizeki S., Nagahiro J., Tamura Y., Masuda S., Shoji F., Morishima S., Tsunematsu S., Matsuda R., Esaki H., Sato T., Miyoshi Y., Watanabe T., Nihei T., Kawamura N., Kaburagi H., Tetsuka U., Mori S., Tabuse S.

- 2) Mori Technical Award 1990 Yamakage I., Konishi T., Horio M., Yoshida S. [Developing study of high speed rice transplanter]

#### Publishing

- 1) Journal of the Japanese Society of Agricultural Machinery (Nogyokikai gakkaisi) bimonthly Vol. 52, No.1-6 in 1990
- 2) Proceedings of Annual Meeting of JSAM 1990, ¥6100
- 3) Agricultural Machinery Handbook, pp.994, ¥20000
- 4) JSAM ABSTRACT 1989, pp.32, ¥500 \*\*
- 5) Graphic Processing & Bioproduct Information, pp.102, ¥3000
- 6) Studies of Phito-technology, pp.119, ¥3000
- 7) New Techniques of Fruits Storage & Transportation, pp.71, ¥3000
- 8) Tractor Dynamics by Vector Analysis, pp.98, ¥1800
- 9) Agricultural Machinery in 21 Century, pp.49, ¥2300
- 10) Agricultural Science & Japanese Agriculture, pp.47, ¥900
- 11) International Workshop on Farm Mechanization (Present

- Situation in Developing Countries), pp.107, ¥2300 \*\*
- 12) Proceedings of Annual Meeting of JSAM 1989, ¥4100
  - 13) Soft-technology in Farm Mechanization, pp.63, ¥2500
  - 14) International Symposium on Agricultural Mechanization and International Cooperation in High Technology Era (Proceedings), pp.598, ¥5600

Note \*\*: in English

#### Seminars or Symposium

- ( 4-6 times per year )
- 1990 November, 15-16 Symposium [Intellectual Agricultural Machinery]
- 1990 August, 21 Symposium [New production technique for rice higher qualities]
- 1990 January, 26 Seminar [Graphic processing and Bioproduction Information]

#### International Exchange Activities

- 1) Publishing [JSAM ABSTRACT 1989, 1990]
- JSAM has been publishing "Journal of the Japanese Society of Agricultural Machinery" bimonthly over fifty years. In this Journal, most articles are written in Japanese, although the original papers have each abstract in English. Therefore these may be not so convenient to the agricultural engineers of the overseas.

In 1989, JSAM decided to publish the JSAM ABSTRACTS every year, which consists of the abstracts of the original papers of the annual Journals, as one of the international exchange activities of the society.

- 2) International Workshop on Farm Mechanization —Present Situation in Developing Countries— JSAM guidebook of agricultural mechanization

planning at the developing countries, published in 1976. In this 14 years, many experts of agricultural technology were sent to the developing countries. And now, many foreign students and researchers belong to the university and the local government in Japan. Some of them are also a member of JSAM. This workshop was planned to be a useful guide for the technical exchange and the development planning of appropriate agricultural mechanization in the developing countries.

First International Workshop was held in 1989, and Second one is held in April 1991 at Kyoto.

- 3) International News on every JSAM Journal
- 4) International Exchange Database

JSAM is constructing the database of the technical exchange in the overseas and the trainee or student from the overseas. Each of them includes the name, organization, year, period and etc.

JSAM members have visited many foreign countries for technical exchange by public project or private objective. JSAM database shows that total 490 persons have visited to overseas as shown at **Table 1**.

Table 1

Country	Technical Exchange with	Student from
China	52	49
Taiwan	18	9
Korea	15	11
Indonesia	30	13
Malaysia	51	4
Philippine	23	5
Thailand	41	13
Other Asia	17	13
Africa	10	6
Central, South America	7	3
USA	52	0
Europe	171	2
Australia	3	0
Total	490	128

Also, JSAM members or related organizations have been servicing for technical training or getting the degrees of Master or Doctor. JSAM database shows that total 128 foreign students or trainees have enrolled as shown at Table 1.

**Data-base Committee**

Database of the members' personal data, the papers or farm machinery dimensions are under construction.

**Branch**

Five each Branch has own activity, annual branch meeting 1-2 per year, publishing branch journal 1-2 per year, and Seminars or Symposium.

**JSAM Head Office**

Secretary-General: Kisu, Masayuki

Address: Japanese Society of Agricultural Machinery c/o BRAIN, 40-2, 1-Chome, Nisshin-cho, Ohmiya, Saitama, 331 JAPAN

Phone: 048-652-4119

Fax is available by same telephone number.

**Hokkaido Branch Office**

Address: Dept. of Agricultural Engr., Faculty of Agriculture, University of Hokkaido, 9-Chome, Nishi, Kita-9jyo, Kita-ku Sapporo, 060 JAPAN

Phone: 011-716-2111

**Tohoku Branch Office**

Address: Tohoku Agricultural Experiment Station, 4, Shimokuriyagawa-kahira, Morioka, Iwate, 020 JAPAN

Phone: 0916-41-2145

**Kanto Branch Office**

Address: Dept. of Agricultural Engr., Faculty of Agriculture, Tokyo University of Agriculture and Engineering, 5-8, 3-Chome, Saiwai-cho, Fuchu, Tokyo, 183 JAPAN

Phone: 0423-64-3311

**Kansai Branch Office**

Address: Dept. of Agricultural Engr., Faculty of Agriculture, University of Kyoto, Kitashirakawa Oiwakecho, Sakyo-ku, Kyoto, 606 JAPAN

Phone: 075-753-6167

**Kyushu Branch Office**

Address: Dept. of Agricultural Engr., Faculty of Agriculture, University of Miyazaki, 1-1, Gakuen Kihanadai-Nishi, Miyazaki, 889-21 JAPAN

Phone: 0985-58-2811

**Application to JSAM**

Please send application in the following form and members fee (one year). ■■

**APPLICATION FOR MEMBERSHIP**

I, hereby, apply for membership in the Japanese Society of Agricultural Machinery (JSAM).

Name \_\_\_\_\_ Age \_\_\_\_\_  
 Mailing Address \_\_\_\_\_  
 City \_\_\_\_\_ Country \_\_\_\_\_  
 Organizational Affiliation \_\_\_\_\_  
 Position \_\_\_\_\_  
 Address \_\_\_\_\_

**EDUCATION RECORD**

University \_\_\_\_\_  
 Degree \_\_\_\_\_ Date \_\_\_\_\_  
 Advanced Degrees \_\_\_\_\_

**PROFESSIONAL REFERENCES (please give 2)**

Name \_\_\_\_\_  
 Address \_\_\_\_\_  
 Name \_\_\_\_\_  
 Address \_\_\_\_\_

Annual Dues (All Countries): ¥7000

I enclose ¥ \_\_\_\_\_ in full payment \_\_\_\_\_  
 \_\_\_\_\_  
 Signature

Finally, We hope that this information of JSAM is useful for academic cooperation among all agricultural engineers and scientists in the world.

## Activities by Hokkaido Agricultural Machinery Association

by  
Nobuhito Murai  
Managing Director  
Hokkaido Agricultural Machinery Association  
Mihiro Building, 1-19, Kita 2-jo, Nishi 2-chome, Chuo-ku,  
Sapporo 060, JAPAN

### Organization

Hokkaido Agricultural Machinery Association (H.A.M.A.) was organized to develop the Agricultural Machinery Industry in Hokkaido and to contribute the sound growth of agriculture, forestry, dairy farming and livestock farming. To accomplish these intentions, researches are investigated to develop the industrial technology of agricultural industry in Hokkaido, to rationalize corporations in Hokkaido and to enlarge the market.

The regular members of H.A.M.A. are corporations which have main office and factories in Hokkaido and the number of the members are 40 corporations. The supporting members are corporations which have branch offices in Hokkaido and the number of supporting members are 38 corporations.

The working expenses of H.A.M.A. are membership fees, subsidies and contributions. H.A.M.A. is administered by a president, two vice presidents, a managing director, an executive director and ten members of board

of directors.

The total sum of shipment of products made in the regular members were ¥20,330,000,000 in 1989 and the sum in 1990 will be ¥21,540,000,000. The rate of increase will be 6.0%. The shipment of fertilizing, seeding and keeping machinery is the highest of all and it is 25.9% of the total amount. Then, the shipment of livestock machinery was 22.5% of all and the shipment of machinery for upland farming was 21.2%, respectively. And cultivating and tilling machinery, including machinery for land reclamation, was 17.8%.

69.5% of the total sum was sold in Hokkaido and 30.1% of all was shipped to other prefecture in Japan. And 0.4% of the sum was exported. The shipment to out of Hokkaido and the amount of export will be increasing in the near future.

### Activities

- 1) Offering informations about agricultural mechanization and enlightening
- 2) Researching and investigating

- agricultural mechanization and publishing books or pamphlets
- 3) Offering or entrusting tests and investigations of agricultural machinery
- 4) Researching and investigating the development of agricultural machinery
- 5) Researching and investigating to expand the demand of agricultural machinery, and to hold symposiums, demonstrations and courses
- 6) Giving suggestions to the government and public offices and cooperating with them in carrying out policies
- 7) Cooperating with organizations concerned

Following activities have been continued up to date:

“*Nogyokikai Hokkaido (in Japanese)*” is published monthly and it has about two thousand circulation. It is distributed to members of H.A.M.A., public offices, research and experimental institutions, agricultural organizations and farmers.

*Agricultural machinery* is inspected according to the criterion established by the government.

However, there is some differences between farming in Hokkaido and farming in other prefecture in agricultural environment, such as scale of farm land, crop, etc. Therefore not all agricultural machinery used in Hokkaido are inspected. Then Hokkaido Prefectural Agricultural Experiment Station inspected some agricultural machinery in place of the government. H.A.M.A. receives an experiment station. The board of Hokkaido Experiment Result Committee investigates the results of inspections. H.A.M.A. publishes the results and distribute them. About 30 machineries are inspected in a year.

H.A.M.A. may receive financial support for projects of investigation and development of agricultural machinery from the government and the prefectural office. H.A.M.A. designates the corporation to promote the project in cooperation with research and investigating institutions. Some of recent projects were Introduction of Mechatronics and Application of New-material.

*Agricultural technical exchanges* between Hokkaido and Tohoku area have become very attractive, because Seikan tunnel has been opened to traffic. 11 members of H.A.M.A. participated in the agricultural machinery exhibition in Iwate prefecture in 1990,

and presented agricultural machinery and technology in Hokkaido. In order to expand the demand of agricultural machinery in Hokkaido, exchanges between Hokkaido and Tohoku area will be intended to become more active in future.

H.A.M.A. supports Tokachi agricultural machinery exhibition and the conference of soil (Tuchiwo-kangaeru-kai).

H.A.M.A. sponsors seminars about technology, including seminars with different industries.

H.A.M.A. sponsors technical courses several times a year.

#### International exchange

Inquiries about agricultural machinery and technical references have been increased from Korea, Taiwan, East Europe and Siberia. H.A.M.A. published English catalogue and distributes it. We also furnished technical data required.

In 1990, tours to Korea and west coast in U.S.A. were held and technical exchange and market research were accomplished. Agricultural machinery used in Hokkaido has been developed with reference to large machinery made in Europe and North America, however, higher technology of agricultural machinery in Hokkaido has been highly evaluated.

#### Outline of Agriculture in Hokkaido

Hokkaido is the northernmost island in Japan and its key industry is agriculture. The land utilized for agriculture in Hokkaido totals, 1,198,000 ha (2.97 million acres), which is 22.4% of the national sum. Number of farm households are 105,970 and the average cultivated area per farm is 11.3 ha and the area is as ten times large as farm in other prefecture. The average cultivated area in Tokachi is 24.3 ha and the area in Nemuro, where the main is livestock, is 47.6ha. Tokachi is in the center of Hokkaido and Nemuro is in the easternmost of Hokkaido. The average area in these regions are as large as in Europe.

Total area of paddy field is 250,000ha, which is about 8.6% of the national sum, area of upland field is 437,300 ha (34.4% of the national sum), and grassland is 506,400 ha (80.2% of the national sum). It is recognized that Hokkaido is the typical area of upland and dairy farms.

The number of tractors in Hokkaido are 130,150 and the average number of tractors of a farm are 1.2. The average operating area for a tractor is 9.2 ha. ■■

## Main Products of Agricultural Machinery Manufacturers in Japan

by  
Shin-Norinsha Co., Ltd.  
No. 7, 2-chome, Kanda Nishikicho  
Chiyoda-ku, Tokyo 101 Japan

Introduced here are the main products of agricultural machinery manufactures in Japan with a number of photographs.

The products are developed and improved for both foreign and domestic markets. For further information please refer to the manufacturers contained in the directory.



The ARIMITSU Greenhouse Sprayer. This machine delivers uniform ultra fine particles resulting in superior coverage on upper and lower leaf surfaces.

☆ ★ ☆



BUNMEI Sugarcane Harvester NB-11. The small walking tape harvester.



CHIKUSHIGO Carrot Washing Machine. Nine rolling brushes assure high efficiency. Wide outlet opening helps easy handling. Efficiency: 100kg/3-5min.



CHIKUSUI CANYCOM SE2301 Rigid dumper for construction site (SE2301/2,000kg. Payload, 23HP max.).

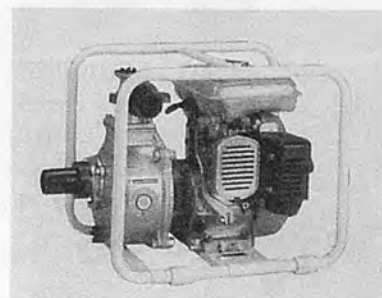

DAISHIN Engine Pumps "CORAL" Model SCL-50.

Suitable for general purpose pumping, irrigation, water carting in agriculture, water transfer over long distances, public works, etc. Max. total head: 32m (105ft). Suction lift: 8.5m (28ft). Max. capacity: 520ℓ/min. Standard capacity: 15m-210ℓ/mm. Engine power: 3.1-3.5HP.



ISEKI Tractor Landmax T825. Mounted with 88 HP (5,393cc) Diesel engine. The 6-cylinder, well-balanced engine runs without noise and dynamically performs any type of work.



ISEKI Combine Frontier HL500. Super Rolling mechanism always controls the position of the body at level by the help of sensors. Working width: 1,650mm-1,700mm (5 row). Engine power: 50HP (2,600cc).



KOBASHI Rotor KA Series with

4-point auto-hitch. Working width: 220cm. Required tractor horsepower: 50-65.



KIORITZ U.L.V. Sprayers. DM-9, DM-3500, DM-4500, DM-5500, PB-4500 has been attached with U.L.V. (Ultra Low Volume) nozzle, Model DMULV-1. These sprayers are used for environmental hygiene control such as malaria prevention, etc. as well as general purpose applications.



KUBOTA Diesel Tractor L3250 with 4-cylinder engine. Engine output (DIN) 26.8kW. Incomparable performance. Wide choice of accessories.



KUBOTA Diesel Ride-on Power

G1900S with optional supermanoeuvrable 4-wheel steering. Engine: 3-cycle, liquid-cooled diesel 18HP/719cc.



KUBOTA Power tiller TF55 with single cylinder, 4-cycle, air-cooled engine. Maximum power 2.94kW.



MAMETORA Tiller MC-210. Compact and light weight crop security tiller. Engine: 5HP.

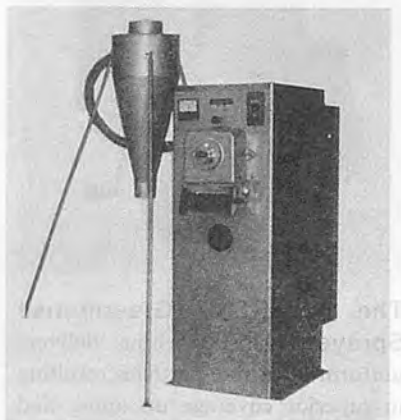

MARUSHICHI Rice Whitening Machine Echo-Star M3. Double jet suction mechanism. Low breakage rate and power. Power: 2.2kW, Capacity: 180-240kg/h.



**MARUYAMA Portable Power Sprayers MSO55D.** Engine: Air-cooled, 2-cycle, output 22.6cc, Pump: Suction capacity 5.1l/mm, max pressure 25kg/cm<sup>2</sup>, Weight: 8.5kg.



**NOZAWA Fruits Worker.** Mobile elevating platform for orchard works: from harvesting to pruning. Control gears on the platform. Mounted with 5PS engine.



**ROBIN Power Rotor PRO400.** Compact design, light weight, safe and easy to use. Engine displacement: 121cc (max. 2.8HP/1,800rpm), Weight: 56kg.

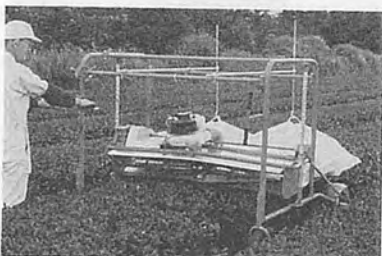

**MATSUMOTO Tea Harvester MST-E2.** Simple and easy operation. Self-propelling; Labor-saving. Picks best quality leaves with high efficiency.

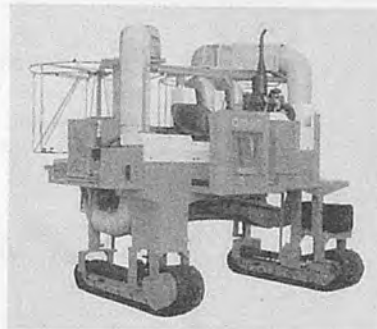

**OCHIAI Riding Type Tea Picking Machine OM-25.** Full working width cutter bar. Stepless speed control. Water-cooled Diesel engine 28.5PS.



**SASAKI Speed Sprayer RS-660Z.** Engine: water-cooled diesel 32HP. Drive system: 6-wheel drive, 600l tank. Air output: 560m<sup>3</sup>/min. Pump output: 94l/min. Dry weight: 1,220kg.

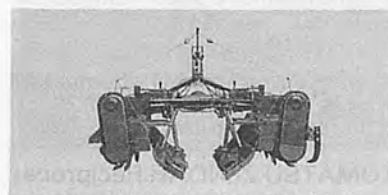
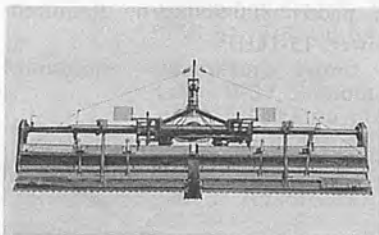

**NIPLO Wing Harrow HW-4101B** folded by hydraulic power for transport. Working width: 417cm; Required tractor horsepower: over 50.



**OREC Crop Security Equipment Ace Rotor AR700.** Wide range use: cultivation to ridging. Mounted with 75PS engine.



**SHIBAURA Tractor Stiger V.** Eased works with car-ride feeling. Synchromesh transmission and column shift employed. Engine horsepower: 70-80.

☆ ★ ☆



SHIZUOKA Single Grain Moisture Meter CTR-160A. For larger size grains (maize or soybean). Measures a lot of 20 grains.

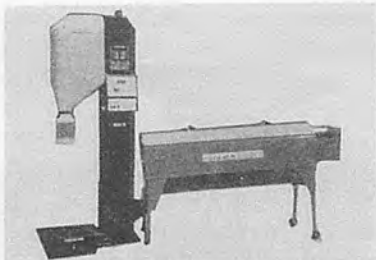

TIGER KAWASHIMA Rice Combi and Grader. Rice grading machine and automatic weighting and packaging.



YANMAR Combine Harvester CA700. Engine: vertical, 3-cycle water-cooled diesel 70HP/2,600rpm. Working width: 2,060mm. Grain tank capacity: 1.5m<sup>3</sup>.

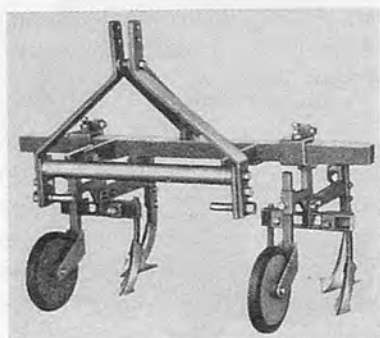

SUKIGARA Double Row Cultivator Model TBC. The row width can be controlled easily and quickly by adjusting each bolt at the left and right of tool bar. Row width: 600-900mm. Suitable working speed: 3-5km/h. Power required: 11-20HP.



YAMAMOTO Test Whitening Machine VP-30T: Type of milling: vertical. Weight: 24kg. Power required: 0.3kW. Capacity: 30kg/h. Hopper holding capacity: 5kg.

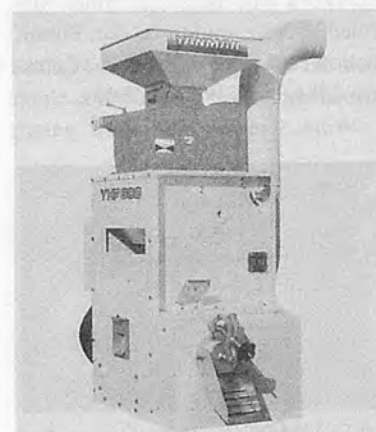

YANMAR Rice Huller/Polisher Mill Mate YHP800. This machine is a complete direct-through rice mill consisting of a hulling section winnower and polishing section. Capacity in paddy 800-900kg/h. Required power: 15-18HP.



SUNWA Hopeman HM-1000 Mounted with 9PS diesel engine transmission: Forward/reverse 3-step each.



YANMAR Diesel Tractor F97. Engine: vertical, 4-cycle, water-cooled diesel 97HP/2,200rpm. Weight: 2,980kg. Transmission: gear shifting F12xR4. Drive system: 4-wheel drive.

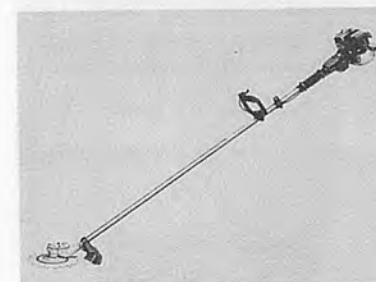

KOMATSU ZENOAH Reciprocator SGC220DL. Engine: 22.5cc, Dry weight: 6.5kg, Cutting Blade: 230mm, 20-toothed, heat-treated steel blade.

☆ ★ ☆



## Directory

Arimitsu	Arimitsu Industrial Co., Ltd.—7-4, 1-chome, Fukae-kita, Higashinari-ku, Osaka, 537. Tel. 06-973-2010	Mitsubishi	Mitsubishi Agricultural Machinery Co., Ltd.—603, Kanda-kaji-cho 3-chome Chiyoda-ku, Tokyo, 101. Tel. 03-3258-0116
Bunmei	Bunmei Noki Co., Ltd.—11-4, 1-chome, Korimoto-cho, Kagoshima-city, 890. Tel. 0992-54-5121	Niplo	Matsuyama Plow Mfg. Co., Ltd.—2949, Shiokawa, Maruko-machi, Chiisagata-gun, Nagano-pref., 386-04. Tel. 0268-35-0300
Chikushigo	Chikushigo Co., Ltd.—29-3, Ino, Umicho, Kasuya-gun, Fukuoka-pref., 811-21. Tel. 092-932-1662	Nozawa	Nozawa Mfg. Co., Ltd.—224-1, Naganuma-cho, Isezaki-city, Gunma-pref., 372. Tel. 0270-32-1315
Chikusui	Chikusui Canycom Inc.—90-1, Fukumasu, Yoshii-machi, Ukiha-gun, Fukuoka-pref., 893-13. Tel. 09437-5-2195	Ochiai	Ochiai-Shoji Co., Ltd.—58, Nishikata, Kikugawa-cho, Ogasa-gun, Shizuoka-pref., 439. Tel. 0537-36-2161
Daishin	Daishin Co., Ltd.—3-23-1, Yoyasu-cho, Ogaki-city, 503. Tel. 0584-75-5011	Orec	Orec Co., Ltd.—23-4, Jyojima, Jyojima-cho, Mizuma-gun, Fukuoka-pref., 830-02. Tel. 0942-62-3161
Honda	Honda Motor Co., Ltd.—1-1, 2-chome, Minamiaoyama, Minato-ku, Tokyo, 107. Tel. 03-3423-1111	Robin	Fuji Robin Industries Ltd.—8-1, 1-chome, Nishishinjyuku, Shinjyuku-ku, Tokyo, 160. Tel. 03-3348-2416
Iseki	Iseki & Co., Ltd.—3-6, Kioi-cho, Chiyoda-ku, Tokyo, 102. Tel. 03-3238-5265	Sanyo	Sanyo Kiki Co., Ltd.—3858, Shinjyo, Satoshicho, Asakuchi-gun, Okayama-pref., 719-03. Tel. 08656-4-2871
Kaaz	Kaaz Corporation—387-1, Gomyo, Saidaiji, Okayama-city, Okayama-pref., 704. Tel. 08694-2-1111	Sasaki	Sasaki Corp. Ltd.—1-259, Satonosawa, Towada-city, Aomori-pref., 034. Tel. 0176-22-3111
Kawasaki	Kawasaki Giken Co., Ltd.—348-1, Kanaya-kawara, Kanaya-cho, Haibara-gun, Shizuoka-pref., 428. Tel. 0547-46-1113	Satake	Satake Engineering Co., Ltd.—2-30, Saijo-nishihonmachi, Higashihiroshima-city, Hiroshima-pref., 724. Tel. 0824-23-3111
Kioritz	Kioritz Corporation—7-2, Suehirocho 1-chome, Oume-city, Tokyo, 198. Tel. 0428-32-6118	Shibaura	Ishikawajima-Shibaura Machinery Co., Ltd.—32-7, 5-chome, Sendagaya, Shibuya-ku, Tokyo, 151. Tel. 03-3358-4211
Kobashi	Kobashi Kogyo Co., Ltd.—684, Nakaune, Okayama-city, 701-02. Tel. 0862-98-3111	Shizuoka	Shizuoka Seiki Co., Ltd.—4-1, Yamana-cho, Fukuroi-city, Shizuoka-pref., 437. Tel. 0538-42-3114
Komatsu-Zenoah	Komatsu-Zenoah Co., Ltd.—142-1, 2-chome, Sakuragaoka, Higashiyamato-city, Tokyo, 189. Tel. 0425-61-2141	Sukigara	Sukigara Agricultural Machinery Co., Ltd.—38, Sairinji, Yahagi-cho, Okazaki-city, Aichi-pref., 444. Tel. 0564-31-2107
Kubota	Kubota Corporation—2-47, Shikitsu-Higashi, 1-chome, Naniwa-ku, Osaka, 556-91. Tel. 06-648-2434	Sunwa	Sunwa Sharyo Mfg. Co., Ltd.—571, Negishi, Sayama-city, Saitama-pref., 350-13. Tel. 0429-54-6611
Mametora	Mametora Agric. Machinery Co., Ltd.—9-37, 2-chome, Nishi, Okegawa-city, Saitama-pref., 363. Tel. 048-771-1181	Tiger	Tiger Kawashima Co., Ltd.—4290, Fujioka, Fujioka-cho, Shimotsuga-gun, Tochigi-pref., 349-13. Tel. 0282-62-3001
Marushichi	Marushichi Co., Ltd.—23-2, 1-chome, Senju, Adachi-ku, Tokyo, 120. Tel. 03-3879-5191	Yamamoto	Yamamoto Co., Ltd.—404, Oinomori, Tendo, Tendo-city, Yamagata-pref., 994. Tel. 0236-53-3411
Maruyama	Maruyama Mfg. Co., Inc.—4-15, 3-chome, Uchi-kanda, Chiyoda-ku, Tokyo, 101. Tel. 03-3252-2281	Yanmar	Yanmar Agricultural Equipment Co., Ltd.—1-32, Chaya-machi, Kita-ku, Osaka-city, 530. Tel. 06-376-6336 ■■
Matsumoto	Matsumoto Kiko Co., Ltd.—9325, Makinouchi, Ei-cho, Ibusuki-gun, Kagoshima-pref., 891-07. Tel. 0993-36-1161		

**Agrimach '91  
Agricultural Machinery Exhibi-  
tion and Symposium  
May 25-28, 1991  
Philippine Trade Training Center  
Metro Manila, Philippines**

Agrimach '91 will be exclusively an exhibition of agricultural machinery to be held in Manila, Philippines from 25 to 28 May 1991, being a continuation of Agrimach' 89 which was held in Bangkok, Thailand.

**The Agrimach '89 Experience**

Agricultural machinery manufacturers from the 11 RNAM participating countries, and from other countries, like Belgium, the Caribbean, the Dominican Republic, France, Japan, Poland, Switzerland, United Kingdom, United States of America, Vietnam, Western Samoa and Zimbabwe, participated in Agrimach '89.

Other participants included representatives of the Economic and Social Commission for Asia and the Pacific (ESCAP), the Food and Agriculture Organization of the United Nations (FAO), the United Nations Industrial Development Organization (UNIDO), the International Rice Research Institute (IRRI) and international development aid institutions, like GTZ, JICA and USAID.

The "one-on-one" discussion sessions among manufacturers during Agrimach '89 promoted joint ventures and licensing arrangements for machinery manufacture.

Out of 96 scheduled discussions, 61 were potentially fruitful. The on-going negotiations among the manufacturers indicate a keen interest in acquiring/transferring new technologies from one country to another.

**What to Expect at Agrimach '91**

Exhibition of various machinery for food crops production, poultry, horticulture, agroindustry/processing.

Symposium on business opportu-

nities in agricultural machinery manufacture, agricultural mechanization technologies and marketing trends in agricultural machinery.

Field Trips to farms, agro-industrial centers and research institutes.

Field Demonstrations of locally-developed as well as selected agricultural machinery on display.

One-on-One Discussions for arranging joint ventures and licensing arrangements for machinery manufacture.

Opportunity for expanding trade in agricultural machinery.

More countries and international organizations, including non-governmental organizations are expected to participate in Agrimach '90. For further information contact:

Secretariat  
Agrimach '91  
c/o RNAM  
UNDP, P.O. Box 7285, DAPO  
1300 Domestic Road Passy City,  
Metro Manila Philippines

**Intensive Weed Management  
Course**

**July 8-26, 1991**

**International Plant Protection  
Center**

**Oregon State University  
Corvallis, Oregon, U.S.A.**

The International Plant Protection Center at Oregon State University (USA) will again conduct an intensive 3-week, "Hands-on" Weed Management Strategies shortcourse in 1991.

"Participants in previous courses were enthusiastic about the experience they gained," said IPPC Interim Director F.S. Conklin. "We were pleased to attract participants from 10 countries on three continents, exchange information with them and, we felt, provide them with knowledge that was appropriate both to their nation's

development and to their personal work and careers."

The 1991 WMS course, scheduled during July 8-26 at Corvallis, Oregon, will utilize university facilities including a nearby 90-hectare research farm where participants will observe and discuss ongoing research and then design and conduct their own weed management experimnts.

Each WMS course participant receives a mini-library of up-to-date weed management technical publications (worth approximately US\$395) for use during the course and, after course completion, free shipment to the participants's duty post.

The WMS course is designed for researchers, graduate students, farm managers, and government specialists involved with conducting or administering weed management programs, particularly in situations where resources are often limited. Participants need a command of spoken English and the minimum of a bachelor's degree or equivalent.

The basic course fee (tentatively US\$3,000) covers matriculation, individual rooms, most meals, and all supplies and local transportation during the course. Participants are responsible for their own financial support including the course fee, transportation to Oregon and return home, and personal expenses. IPPC does not offer scholarships.

A free descriptive brochure is available from: WMS91 Course, International Plant Protection Center, Oregon State University, Corvallis, OR 97331-3904/USA.

**1991 International Agricultural  
Mechanization Conference  
October 16-20, 1991  
Beijing, China**

**Sponsored by: Chinese Society of**

## INQUIRY and REQUEST to AMA

Please let us know your need. We shall promptly reply them. Inquire on any catalog listed in the advertisement in this issue. We shall try our best to serve you. We welcome articles of interest to agricultural mechanization.

Fill in the reverse side of this card and send us by sealed letter.

**FARM MACHINERY INDUSTRIAL RESEARCH CORP.**

7-2 Kanda Nishikicho Chiyoda-ku Tokyo-Japan 101



# SUBSCRIPTION/ORDER FORM

AGRICULTURAL MECHANIZATION IN ASIA, AFRICA AND LATIN AMERICA (AMA)  
Issued Quarterly

Subscription Rate (includes surface mail postage)

Annual (4 issues) ----- ¥.6,000  
Single copy ----- ¥.1,700

Back Issues (1971-75, ¥.2,000 per copy)  
(1976-77, ¥.1,200 per copy)  
(1978-80, ¥.1,500 per copy)

- |  |  |   |
|--|--|---|
| <input type="checkbox"/> Spring, 1971                                      | <input type="checkbox"/> Vol.7 No.2, Spring, 1976            | <input type="checkbox"/> Vol.9 No.4, Autumn, 1978             |
| <input checked="" type="checkbox"/> Vol.2 Autumn, 1971                     | <input type="checkbox"/> Vol.7 No.3, Summer, 1976            | <input type="checkbox"/> Vol.10 No.1, Winter, 1979            |
| <input type="checkbox"/> Vol.3 No.1, 1972                                  | <input type="checkbox"/> Vol.7 No.4, Autumn, 1976            | <input type="checkbox"/> Vol.10 No.2, Spring, 1979            |
| <input type="checkbox"/> Vol.3 No.2, Summer, 1972                          | <input type="checkbox"/> Vol.8 No.1, Winter, 1977            | <input type="checkbox"/> Vol.10 No.3, Summer, 1979            |
| <input checked="" type="checkbox"/> Vol.4 No.1, Spring, 1973               | <input type="checkbox"/> Vol.8 No.2, Spring, 1977            | <input type="checkbox"/> Vol.10 No.4, Autumn, 1979            |
| <input type="checkbox"/> Vol.4 No.2, Autumn, 1973                          | <input type="checkbox"/> Vol.8 No.3, Summer, 1977            | <input checked="" type="checkbox"/> Vol.11 No.1, Winter, 1980 |
| <input checked="" type="checkbox"/> Vol.5 No.1, Summer, 1974               | <input type="checkbox"/> Vol.8 No.4, Autumn, 1977            | <input checked="" type="checkbox"/> Vol.11 No.2, Spring, 1980 |
| <input type="checkbox"/> Vol.6 No.1, Spring, 1975                          | <input type="checkbox"/> Vol.9 No.1, Winter, 1978            | <input type="checkbox"/> Vol.11 No.3, Summer, 1980            |
| <input checked="" type="checkbox"/> Vol.6 No.2, Autumn, 1975               | <input type="checkbox"/> Vol.9 No.2, Spring, 1978            | <input type="checkbox"/> Vol.11 No.4, Autumn, 1980            |
| <input type="checkbox"/> Vol.7 No.1, Winter, 1976                          | <input checked="" type="checkbox"/> Vol.9 No.3, Summer, 1978 | <b>*: Indicates issues out of stock.</b>                      |
| <input type="checkbox"/> Abstract and Index, 1971-80 (Special Issue, 1983) |  |   |

(Check issues and number of copies you wish to order)

Back Issues from 1981, ¥.1,700 per copy (Vol. 12 No. 1 and No. 4 are out of stock)  
Abstract and Index, Special Issue, 1983, ¥2,000 per copy.

Vol. \_\_\_\_\_ No. \_\_\_\_\_, 19\_\_\_\_, \_\_\_\_\_ copy/copies

(check one)

Please invoice me/us

I/We enclose remittance for ¥ \_\_\_\_\_

\*\*\*\*\*

Name: \_\_\_\_\_

Firm: \_\_\_\_\_

Position: \_\_\_\_\_

Address: \_\_\_\_\_

(block letters)

FARM MACHINERY INDUSTRIAL RESEARCH CORP.

7, 2-chome, Kanda Nishikicho, Chiyoda-ku,

Tokyo 101 Japan

Tel. (03)-291-3671-4, 5718

NEWS

AGRICULTURAL MECHANIZATION IN ASIA, AFRICA AND LATIN AMERICA

Agency: **AGRICULTURAL MECHANIZATION IN ASIA, AFRICA AND LATIN AMERICA**  
 Address: **1-1-1, Nishi-Shinjuku, Shinjuku-Ku, Tokyo 162, Japan**  
 Telephone: **03-3353-1111**  
 Fax: **03-3353-1112**  
 E-mail: **amaj@amaj.or.jp**



Back Issues 1971-75 ¥2,000 per copy  
 1976-77 ¥1,700 per copy

**FARM MACHINERY INDUSTRIAL RESEARCH CORP.**

**7-2-CHOME, KANDA NISHIKICHO, CHIYODA-KU  
 TOKYO, 101 JAPAN**

- Abstract and Index, 1971-80 (Special Issue, 1987)
- Vol. 7, No. 1, Winter, 1976
- Vol. 7, No. 2, Summer, 1976
- Vol. 7, No. 3, Spring, 1976
- Vol. 7, No. 4, Autumn, 1976
- Vol. 7, No. 5, Winter, 1976
- Vol. 7, No. 6, Summer, 1976
- Vol. 7, No. 7, Spring, 1976
- Vol. 7, No. 8, Autumn, 1976
- Vol. 7, No. 9, Winter, 1976
- Vol. 7, No. 10, Summer, 1976
- Vol. 7, No. 11, Spring, 1976
- Vol. 7, No. 12, Autumn, 1976
- Vol. 7, No. 13, Winter, 1976
- Vol. 7, No. 14, Summer, 1976
- Vol. 7, No. 15, Spring, 1976
- Vol. 7, No. 16, Autumn, 1976
- Vol. 7, No. 17, Winter, 1976
- Vol. 7, No. 18, Summer, 1976
- Vol. 7, No. 19, Spring, 1976
- Vol. 7, No. 20, Autumn, 1976
- Vol. 7, No. 21, Winter, 1976
- Vol. 7, No. 22, Summer, 1976
- Vol. 7, No. 23, Spring, 1976
- Vol. 7, No. 24, Autumn, 1976
- Vol. 7, No. 25, Winter, 1976
- Vol. 7, No. 26, Summer, 1976
- Vol. 7, No. 27, Spring, 1976
- Vol. 7, No. 28, Autumn, 1976
- Vol. 7, No. 29, Winter, 1976
- Vol. 7, No. 30, Summer, 1976
- Vol. 7, No. 31, Spring, 1976
- Vol. 7, No. 32, Autumn, 1976
- Vol. 7, No. 33, Winter, 1976
- Vol. 7, No. 34, Summer, 1976
- Vol. 7, No. 35, Spring, 1976
- Vol. 7, No. 36, Autumn, 1976
- Vol. 7, No. 37, Winter, 1976
- Vol. 7, No. 38, Summer, 1976
- Vol. 7, No. 39, Spring, 1976
- Vol. 7, No. 40, Autumn, 1976
- Vol. 7, No. 41, Winter, 1976
- Vol. 7, No. 42, Summer, 1976
- Vol. 7, No. 43, Spring, 1976
- Vol. 7, No. 44, Autumn, 1976
- Vol. 7, No. 45, Winter, 1976
- Vol. 7, No. 46, Summer, 1976
- Vol. 7, No. 47, Spring, 1976
- Vol. 7, No. 48, Autumn, 1976
- Vol. 7, No. 49, Winter, 1976
- Vol. 7, No. 50, Summer, 1976
- Vol. 7, No. 51, Spring, 1976
- Vol. 7, No. 52, Autumn, 1976
- Vol. 7, No. 53, Winter, 1976
- Vol. 7, No. 54, Summer, 1976
- Vol. 7, No. 55, Spring, 1976
- Vol. 7, No. 56, Autumn, 1976
- Vol. 7, No. 57, Winter, 1976
- Vol. 7, No. 58, Summer, 1976
- Vol. 7, No. 59, Spring, 1976
- Vol. 7, No. 60, Autumn, 1976
- Vol. 7, No. 61, Winter, 1976
- Vol. 7, No. 62, Summer, 1976
- Vol. 7, No. 63, Spring, 1976
- Vol. 7, No. 64, Autumn, 1976
- Vol. 7, No. 65, Winter, 1976
- Vol. 7, No. 66, Summer, 1976
- Vol. 7, No. 67, Spring, 1976
- Vol. 7, No. 68, Autumn, 1976
- Vol. 7, No. 69, Winter, 1976
- Vol. 7, No. 70, Summer, 1976
- Vol. 7, No. 71, Spring, 1976
- Vol. 7, No. 72, Autumn, 1976
- Vol. 7, No. 73, Winter, 1976
- Vol. 7, No. 74, Summer, 1976
- Vol. 7, No. 75, Spring, 1976
- Vol. 7, No. 76, Autumn, 1976
- Vol. 7, No. 77, Winter, 1976
- Vol. 7, No. 78, Summer, 1976
- Vol. 7, No. 79, Spring, 1976
- Vol. 7, No. 80, Autumn, 1976
- Vol. 7, No. 81, Winter, 1976
- Vol. 7, No. 82, Summer, 1976
- Vol. 7, No. 83, Spring, 1976
- Vol. 7, No. 84, Autumn, 1976
- Vol. 7, No. 85, Winter, 1976
- Vol. 7, No. 86, Summer, 1976
- Vol. 7, No. 87, Spring, 1976
- Vol. 7, No. 88, Autumn, 1976
- Vol. 7, No. 89, Winter, 1976
- Vol. 7, No. 90, Summer, 1976
- Vol. 7, No. 91, Spring, 1976
- Vol. 7, No. 92, Autumn, 1976
- Vol. 7, No. 93, Winter, 1976
- Vol. 7, No. 94, Summer, 1976
- Vol. 7, No. 95, Spring, 1976
- Vol. 7, No. 96, Autumn, 1976
- Vol. 7, No. 97, Winter, 1976
- Vol. 7, No. 98, Summer, 1976
- Vol. 7, No. 99, Spring, 1976
- Vol. 7, No. 100, Autumn, 1976

(Check issues and number of copies you wish to order)

**1st FOLD HERE**

Back Issues from 1981, ¥1,700 per copy (Vol. 12, no. 1 and No. 4 are out of stock)  
 Abstract and Index, Special Issue, 1983, ¥1,000 per copy.

**AGRICULTURAL MECHANIZATION IN ASIA, AFRICA AND LATIN AMERICA**

(check one)

Please invoice me/us

I/we enclose remittance for ¥

\*\*\*\*\*

Name: \_\_\_\_\_

Address: \_\_\_\_\_

Position: \_\_\_\_\_

**2nd FOLD HERE**

Address: \_\_\_\_\_

Address: \_\_\_\_\_

Address: \_\_\_\_\_

Address: \_\_\_\_\_

Address: \_\_\_\_\_

Address: \_\_\_\_\_

Address: \_\_\_\_\_

Address: \_\_\_\_\_

Address: \_\_\_\_\_

Agricultural Machinery (CSAM), Chinese Academy of Agricultural Mechanization Sciences (CAAMS), China International Conference Centre for Science and Technology

**Theme of the conference:** Agricultural mechanization and engineering technologies serve the agricultural development of the developing countries

**Objectives:** To promote and search development of agricultural mechanization. To exchange development strategy, new idea and achievement of tactic in agricultural mechanization. To exchange new technologies and results in agricultural engineering.

**Language:** The official language of the conference is English.

**Exhibition:** The international exhibition of new technique and achievement on agricultural engineering will be held at Chinese Academy of Agricultural Mechanization Sciences.

**Information and correspondence:** For further information, please write to the organizing committee.

Attn:

Chinese Academy of Agricultural Mechanization Sciences.

No. 1 Beishatan, Deshengmen Wai, Beijing 100083, China

Tel: 2017131-2233, Tlx: 222483 CAAMS CN

Cable: 7651 Beijing, Fax: 86-1-2017326

---

### Asian Association for Agricultural Engineering Formed

---

There are number of autonomous professional Societies throughout the Asian region. In Japan alone there are at least eight societies on associations having Agricultural Engineers among them.

To help strengthen the profession and improve communication among Agricultural Engineers, An Asian Association for Agricultural Engineering

was established on December 5, 1990.

The formalities to establish the Association took place at the closing session of the International Agricultural Engineering Conference, held at the Asian Institute of Technology, Bangkok, December 3-6, 1990.

The objectives of the Asian Association for Agricultural Engineering (AAAE) are as follows:

1. To strengthen the profession of Agricultural Engineering, promote information exchange, improve communications, minimize duplication of activities and optimize use of resources.
2. To publish an international peer-reviewed journal, supervised by an editorial board.
3. To formulate, establish and promote voluntary academic, professional and technical standards of relevance to the profession of Agricultural Engineering in Asia.
4. To support, at the International level, the activities of national Agricultural Engineering societies or related associations and maintain liaison among them.
5. To coordinate and assist in organizing timely international meetings in cooperation with national societies/associations within the Region.

Regular Membership of the Association is US\$ 20/year and for that members will receive regular editions of the Journal, newsletters and other information. Charter, life and corporate membership are available. The Secretariate is at the Agricultural and Food Engineering Division of the Asian Institute of Technology, G.P.O. Box 275554, Bangkok 10501, Thailand. Tel 516-0110 Fax 516-2126.

The first President is Dr. Gajendra Singh (A.I.T.). The first Vice Presidents are Dr. Graeme Quick (IRRI) and Mr. Yoshisuke Kishida (AMA, Shin-Norinsha Co, Ltd).

---

### Joint Announcement by Ford Motor Company and Fiat Group

---

The Fiat Group and Ford Motor Company have signed definitive agreements to form a new company which will merge Fiat's subsidiary Fiat-Geotech and Ford New Holland, Ford's tractor and farm and industrial equipment subsidiary.

The two firms had announced on July 31 that an agreement had been reached to form the new company, that Fiat would have an 80 percent majority interest, and that Ford would receive a cash payment and would hold 20 percent of the new company. The new company intends to preserve the individual market and product identities to both FiatGeotech and Ford New Holland.

Corporate headquarters of the new company will be located in London, England. The new company maintains separate product and market identities developed over almost a century by Ford, New Holland, FiatAgri, Fiat Alis and other subsidiary brands.

---

### 2nd Full-Members Meeting, EIMA

November 7-8, 1990

Bologna, Italy

---

The Club of Bologna comprises more than 60 experts from 30 Countries with the goal of: discussing and defining appropriate strategies for the development of agricultural mechanization; identifying new technological and operational solutions; promoting the exchange of technical information and the international cooperation.

One of the topics the Club of Bologna discussed in depth during its second plenary meeting held at EIMA in Bologna on November 7-8, 1990,

was "New Mechanization to Protect the Agricultural Environment". The discussion itself was based on the fact that the Club is well aware that agricultural activity in every country—whilst providing an attractive rural environment and a natural source of balancing the environment (for example CO<sub>2</sub> reduction in the atmosphere) is one of the factors responsible for various forms of environmental pollution that affect:

- the atmosphere, through the spread of noise, dust, unpleasant odors, ammonia, and the emission of noxious gases. These things have a direct impact on man's welfare as well as on soil acidification, damage to our forests and gradual planetary warming;
- the water, both surface and underground, due to the introduction of pesticides, herbicides and fertilizers (mineral and organic), which also contribute to widespread problems of eutrophication;
- the soil, as a result to the gradual accumulation of components that are not easily degradable with particular reference to heavy metals that may thus enter the food chain.

In addition, another problem, which is becoming increasingly more serious in many areas, concerns the gradual degradation of the soil itself and of its structure, which is due both to external causes based on erosion and endogenous factors originating from unsuitable cultivation practices and/or extreme or inappropriate forms of mechanisation.

On the basis of this analysis and, more importantly, the problems arising from the interaction between land and mechanisation, the need for proper management of animal wastes and the optimization of operations for agrochemical distribution, the Club of Bologna has reached the following

#### Conclusions and Recommendations:

1. In order to reduce the forms of pol-

lution mentioned above: in addition to the encouragement to a return to more natural agricultural systems based on crop rotation and the widespread adoption of forms of "Low-Input Sustainable Agriculture", there are many possibilities for the development and spread of techniques designed to save machinery, work time, energy and agrochemicals through a more rational and efficient use of these factors of production with an increased product and process innovation, assisted by sensing techniques able to control both biological and mechanical aspects.

2. The following is a summary of the major issues that have arisen within this context in terms of the various areas under discussion.

With regard to the interaction between soil and mechanisation, there is a need to develop and spread appropriate technologies designed to:

- remove excess water and control leaching and salinity;
- reduce the loss of soil and nutrients;
- optimize seedbed preparation operations;
- minimize damage due to compaction of the physical structure of the soil;
- incorporate crop residues.

The adoption of techniques and technologies designed to meet these needs requires a common effort in the field of applied research. The goal is to make it possible for farmers to manage their own land in a more effective manner by greatly reducing production costs, increasing the useful periods during which various cultivation operations can be carried out, and defining forms of land "tractability" that will make it possible to carry out various cultivation practices without causing perceptible damage but rather improving soil quality.

Innovative product and process solution (some currently being worked

on), which are designed to reduce tire slippage, decrease the pressure they exert on the soil, organize cultivation according to the criterion of traffic lanes, carry out combined operations (either at the same time as, or after, sowing) and reduce cultivation depth, will also be able to decrease current production costs by 30% and restore vitality to the soil itself.

Within this framework, high contribution could be supplied also by the adoption of remote control system of tyre inflation pressure as well as of higher working speeds, whilst alternative traction devices should also be evaluated.

This scenario must be backed up by the use of: electronics systems for machinery guidance, control and regulation; the application of artificial intelligence, appropriate databases operating in real time, and tools for processing agrometeorological data optimal cultivation planning.

This situation calls for a joint effort made by research and industry in order to come up with fast, conclusive, technical and systems solutions.

3. As far as the proper management of animal wastes is concerned it has to be noted that the nitrogen cycle in the soil is highly inefficient in the most intensive animal-breeding areas, where utilization efficiency is often lower than 0.3, even though it would be possible to create a significant improvement. Therefore, the Club realizes that soil pollution problems are directly related to the surplus of minerals distributed, and that this fact has an impact on:

- the phosphorus saturation of the soil itself;
- the transfer of nitrates to underground water;
- the eutrophication of the water.

4. With regard to the problems posed by the application of agrochemicals, it is necessary to reconfirm the importance of obtaining effective,



uniform treatment (of both pesticides and fertilizers) with minimum formula consumption. Some countries already have legislation limiting the quantities and formulas that may be used. The goal in this case is to decrease the risk of pollution and the costs of the operation itself. While widespread, resolute action should be taken in favor of periodic on-site inspections of the machinery being used as well as its maintenance and performance, considerable innovation is also needed in both machinery components and distribution systems.

The major improvements that should be made on pesticide spraying machine include:

- tank size and shape and stirrer operation to guarantee the complete homogeneity of the mixture to be distributed;
- fan size and position in relation to nozzle layout to ensure that crops are dusted with the minimum possible waste;
- the design of new types of nozzles designed to improve treatment effectiveness using e.g. injection methods as well as solutions for the emission of pesticide near the nozzle;
- the degree of precision and automation of onboard instruments that control and regulate operations, which should be handled by computerized systems;
- improved operator protection.

5. In conclusion, the Club of Bologna feels strongly that there is a fundamental need to support interna-

tional research groups (representing a joint effort on the part of research and industry) to achieve in a short period of time, the above mentioned goals through the development of techniques and technologies designed to strongly reduce agriculturally-created pollution problems and improve the productive and economic results of agriculture.

6. The Club of Bologna also held preliminary discussions on two other topics. Engineering policies and solutions for small farms both in industrialized and in less developed Countries were analyzed. The discussion embraced education and training, infrastructures for equipment distribution and maintenance, economic and price factors, as well as the advance of appropriate technology. Joint ventures for development in less advanced areas were considered.
7. In the final debate, the potential for further reductions in agricultural production costs through engineering advance was analysed. Substantial opportunities for savings in crop and livestock product costs of up to 25% were identified. Rapidly advancing technologies, involving collaboration between engineers and biologists, particularly biotechnology, robotics and information technology are of high economic importance.

---

#### IRRI Threshers in Vietnam

---



Cantho, Vietnam— About 50,000 axial-flow rice threshers have been manufactured, using locally-available components, in the Mekong Delta of Vietnam. They thresh almost 90% of the harvest from the Mekong Delta's 2.3 million hectares of riceland.

The original axial-flow thresher was designed by engineers of the International Rice Research Institute (IRRI) in the Philippines and released for commercial production in the late 1960s. The first prototype thresher was introduced to Vietnam in 1974 by a returning IRRI scholar through the Vietnam Agricultural Machinery Company.

Farmers and mechanics have modified the original IRRI design extensively to suit local conditions. The thresher concept has also been adapted to thresh maize and soybeans by Agricultural Machinery faculty of the University of Agriculture and Forestry, Ho Chi Minh City.

The axial-flow thresher has been the most popular of dozens of IRRI-designed farm machines. About 300,000 axial-flow threshers have been manufactured by more than 1,000 manufacturers worldwide. IRRI does not charge royalties for use of its farm equipment designs. ■■

## BOOK REVIEW

### Practical Agricultural Engineering

(India)

by R.K. Ghosh, S. Swain

The book is designed primarily as an elementary practical text book for students of agricultural engineering degree programme or/and agriculture degree programme. It may also serve as an help study for students at the post-graduate level in agricultural engineering or agricultural colleges/universities. In addition to the student readership, the book will be a valuable reference to professional engineers and agricultural scientists working in the field. The students/trainees in agricultural polytechnics, krishi vigyan kendras, rural institutes and similar other organisations having a programme in agriculture or agricultural engineering would find this book useful. It is also hoped that the book will be valuable to similar groups in the developing countries of Asia and Africa.

Size: 24 × 19 cm, pp 182, soft-cover. Price Rs. 125.00.

Published by Naya Prakash  
P.O. Box 11468  
206 Bidhan Sarani  
Calcutta 700006  
India

### JSAM Abstracts 1989

(Japan)

JSAM has been publishing "Journal of the Japanese Society of Agricultural Machinery" bimonthly over fifty years. In this Journal, most articles are written in Japanese, although the original papers have each abstract in English. Therefore these may be not so convenient to the agricultural engineers of the overseas.

Recently the International Committee of the society decided to publish the JSAM ABSTRACTS every year, which consists of the abstracts of the original papers of the annual Journals, as one of the international exchange activities of the society.

The first bulletin "JSAM ABSTRACTS 1989" will be useful for academic cooperation among all agricultural engineers and scientists in the world.

Size: 26 × 18 cm, pp 32, paper-cover

Published by Japanese Society of Agricultural Machinery c/o IAM /BRAIN  
Nisshincho, 1-40-2, Omiya-shi  
Saitama-ken 331, Japan

### Publications of the International Agricultural Research and Development Centers

(Philippines)

Los Banos, Philippines—IRRI has released a 1989 edition of a catalog of all publications and educational materials published by 22 International Agricultural Research Centers: *Publications of the International Agricultural Research and Development Centers*.

The 730-page catalog is the world's largest compilation of titles on agricultural science for development. It includes 50-word descriptions of all major Center publications. Included is a 182-page keyword index to help the reader locate all publications in certain fields (i.e. cytogenetics, insect resistance, maize). The catalog will also be available soon on computer disk.

IRRI published the catalog on behalf of all Centers, and is handling its distribution. It can be purchased for US\$ 10.00 plus \$10.00 for postage and handling by airmail or \$3.00 by sur-

face mail from the IRRI Information Center, P.O.Box 933, Manila, Philippines.

### Mechanics in Agriculture

(U.S.A.)

by Lloyd J. Phipps, C.L. Reynolds

This book is designed to serve the needs of high school students, post-high schools students, university students, and adults engaged in or preparing for occupations requiring knowledge and skill in agricultural mechanics. Its contents are also designed to serve persons who have an avocational or hobby interest in agricultural mechanics.

Emphasis has been placed on the "why" as well as the "how." Persons may use the contents of the book to obtain an overview and basic understanding of a problem area in agricultural mechanics. This basic overview and understanding will make more meaningful the details learned in the shop and in the field.

The book emphasizes the basic principles involved in all types of agricultural mechanics activities, from shop work to soil and water management, and including electronic monitoring and automation devices used in the various agricultural occupations.

The new and broadened objectives of agricultural education guided the authors in the selection and organization of the materials. The materials included should be of value to persons engaged in or preparing to engage in (1) production agriculture and (2) off-farm agricultural occupations.

Size: 26 × 18 cm, pp 755, hard-bound. List price \$31.95.

Published by Interstate Publishers, Inc. P.O.Box 50, Danville, IL 61834-0050 U.S.A. ■■

## INSTRUCTIONS TO AMA CONTRIBUTORS

The Editorial Staff of the AMA requests contributors of articles for publication to observe the following editorial policy and guidelines in order to improve communication and to facilitate the editorial process :

### Criteria for Article Selection

Priority in the selection of articles for publication is given to those that —

- a. are written in the English language ;
- b. are relevant to the promotion of agricultural mechanization, particularly for the developing countries ;
- c. have not been previously published elsewhere, or, if previously published are supported by a copyright permission ;
- d. deal with practical and adoptable innovations by small farmers with a minimum of complicated formulas, theories and schematic diagrams ;
- e. have a 50 to 100-word abstract, preferably preceding the main body of the article ;
- f. are typewritten, double-spaced, under 4,000 words (approximately equivalent to 8 pages of AMA-size paper) ; and those that
- g. are supported by authentic sources, reference or bibliography.

### Rejected/Accepted Articles

- a. As a rule, articles that are not chosen for AMA publication are not returned unless the writer(s) asks for their return and are covered with adequate postage stamps. At the earliest time possible, the writer(s) is advised whether the article is rejected or accepted.
- b. When an article is accepted but requires revision/modification, the details will be indicated in the return reply from the AMA Chief Editor in which case such revision/modification must be completed and returned to AMA within three months from the date of receipt from the Editorial Staff.
- c. "The AMA does not pay for articles published. However, the writers are given collectively 5 free copies (one copy air-mailed and 4 copies sent by surface/sea mail) of the AMA issue wherein their articles are published. In addition, a single writer is given 25 off-prints of the article and plural writers are given 35 off-prints (also sent by surface/sea mail)"

### Procedure

- a. Articles for publication (original and one-copy) must be sent to AMA through the Co-operating Editor in the country where the article originates. (Please refer to the names and addresses of Co-operating Editors in any issue of the AMA). However, in the absence of any Co-operating Editor, the article may be sent directly to the AMA Chief Editor in Tokyo.
- b. Contributors of articles for the AMA for the

first time are required to attach a passport-size ID photograph (black and white print preferred) to the article. The same applies to those who have contributed articles three years earlier. In either case, ID photographs taken within the last 6 months are preferred.

- c. The article must bear the writer(s) name, title/designation, office/organization, nationality and complete mailing address.

### Format/Style Guidance

- a. Whether the article is a technical or popular contribution, lecture, research result, thesis or special report, the format must contain the following features :
  - i) a brief and appropriate title ;
  - ii) the writer(s) name, designation/title, office/organization ; and mailing address ;
  - iii) an abstract following ii) above ;
  - iv) body proper (text/discussion) ;
  - v) conclusion/recommendation ; and a
  - vi) bibliography
- b. The pages must be numbered (Arabic numeral) successively at the top center. Tables, graphs and diagrams must likewise be numbered. Table numbers must precede table titles, e.g., "Table 1. Rate of Seeding per Hectare". Such table number and title must be typed at the top center of the table. On the other hand, graphs, diagrams, maps and photographs are considered figures in which case the captions must be indicated below the figure and preceded by number, e.g., "Figure 1. View of the Farm Buildings".
- c. Tables and figures must be preceded by texts or discussions. Inclusion of such tables and figures not otherwise referred to in the text/discussion must be avoided.
- d. Tables must be typed clearly without vertical lines or partitions. Horizontal lines must be drawn only to contain the sub-title heads of columns and at the bottom of the table.
- e. Express measurements in the metric system and crop yields in metric tons per hectare (t/ha) and smaller units in kilogram or gram (kg/plot or g/row).
- f. Indicate by footnotes or legends any abbreviations or symbols used in tables or figures.
- g. Convert national currencies in US dollars and use the later consistently.
- h. Round off numbers, if possible, to one or two decimal units, e.g., 45.5kg/ha instead of 45.4762kg/ha.
- i. When numbers must start a sentence, such numbers must be written in words, e.g., "Forty-five workers . . . , or Five tractors . . ." instead of "45 workers . . . , or, 5 tractors."

# Co-operating Editors



E A Baryeh    A M Hossary    B S Pathak    D B Ampratwum    R J Bani    I K Djokoto    D K Some    M S Choudhury    J C Igbeka    E U-Odigboh



K C Oni    N G Kuyembh    A H Abdoun    A B Saeed    E S Eldin    A I Khatibu    S Tembo    I de A Nääs    A E Ghaly    A A Valenzuela

## --- AFRICA ---

**Edward A. Baryeh**  
Professor, ENSIAAC, BP455, Nagaounde, Cameroon

**Ali Mahmoud El Hossary**  
Senior Under-Secretary for Engineering Affairs, Ministry of Agriculture, Dokki, Cairo, Egypt

**B.S. Pathak**  
Project Manager, Agric. Implements Research and Improvement Centre, Melkassa, Ethiopia

**David Boakye Ampratwum**  
Part-Time Lecturer, Agricultural and Food Engineering, University of Ghana, Legon, Ghana

**Richard Jinks Bani**  
Lecturer & Co-ordinator, Agric. Engineering Div., Faculty of Agriculture, University of Ghana, Legon, Ghana

**Israel Kofi Djokoto**  
Senior Lecturer, University of Science and Technology, Kumasi, Ghana

**David Kimutai arap Some**  
Lecturer, Dept. of Agric. Engineering, University of Nairobi, Nairobi, Kenya

**Md. Shahansha Uddin Choudhury**  
Professor of Agricultural Engineering, University of Sokoto, P.M.B. 2346, Sokoto State, Nigeria

**Joseph Chukwugozium Igbeka**  
Professor, Dept. of Agricultural Engineering, Faculty of Technology, University of Ibadan, Nigeria

**E.U. Odigboh**  
Professor & Head of Agricultural Engineering Department, University of Nigeria, Nsukka, Nigeria

**Kayode C. Oni**  
Senior Lecturer, Dept. of Agric. Engineering, University of Ilorin, P.M.B. 1515, Ilorin, Nigeria

**N.G. Kuyembh**  
Dean, Faculty of Agriculture and Head, Dept. of Agric. Engineering, Njara University College, University of Sierra Leone, Sierra Leone

**Abdien Hassan Abdoun**  
Member of Board, Amin Enterprises P.O. Box 1333 Khartoum, Sudan

**Amir Bakheit Saeed**  
Lecturer, Dept. of Agric. Engineering, Faculty of Agriculture, University of Khartoum, Khartoum, Sudan

**EITag Seif Eldin**  
Mailing Address: Dept. of Agric. Mechanization, College of Agriculture, P.O. Box 32484, Al-Khod, Sultan Qaboos University, Muscat, Sultanate of Oman

**Abdisalam I. Khatibu**  
National Project Coordinator and Director, FAO Irrigated Rice Production, Zanzibar, Tanzania

**Solomon Tembo**  
Lecturer and Acting Chairman, Dept. of Soil Science and Agric. Engineering, University of Zimbabwe, Harare, Zimbabwe

## --- AMERICAS ---

**Irenilza de Alencar Nääs**  
Professor, Agricultural Engineering College, UNICAMP, Agricultural Construction Dept., P.O. Box 6011, 13081 - Campinas - S.P., Brazil

**Abdelkader Elmetwally Ghaly**  
Associate Professor, Agric. Engineering Dept., Faculty of Engineering, Technical University of Nova Scotia, Halifax, Nova Scotia, Canada

**A.A. Valenzuela**  
Dean, College of Agriculture, University of Concepción-Chile Chillan, Chile

**Armed Hossain Mirdha**  
Professor & Head, Area of Research in Agril. Production, Academic Div. of Agril. & Livestock Sc., Sierra Unit, Autonomous University Juarez de Tabasco, Apdo. Posta-960, Admon. de Correos No. 2 Villahermosa, C.P. 86100 Tabasco, Mexico

**Omar Ulloa-Torres**  
Prof.-Investigator, Dept. of Agric. Machinery, University of Chapingo, Chapingo, Mexico 56230 Mexico

**William J. Chancellor**  
Professor, Agricultural Engineering, University of California, Davis, California 95616, U.S.A.

**Megh R. Goyal**  
Prof./Agric. Engineer, Univ. of Puerto Rico, Mayaguez Campus HC 02 Box 7115 Juana Diaz, PR 00665-9601 U.S.A.

**Allan L. Philips**  
Director, Agric. Engineering Dept., the University of Puerto Rico, Mayaguez, Puerto Rico 00708, U.S.A.

## --- ASIA and OCEANIA ---

**Shah M. Farouk**  
Professor, Dept. of Farm Power & Machinery, Bangladesh Agricultural University, Mymensingh, Bangladesh

**Mohammed A. Mazed**  
Chief Scientific Officer & Head of Agric. Engineering Div., Bangladesh Agricultural Research Institute, Joydebpur, Dhaka, Bangladesh

**Wang Wanjun**  
Senior Engineer of Chinese Academy of Agricultural Mechanization Sciences, Honorary President of Chinese Society of Agricultural Machinery, No. 1 Beishatan, Deshengmen Wai, Beijing, China

**A.M. Michael**  
Director, Indian Agricultural Research Institute, New Delhi 110012, India

**J.P. Mittal**  
Project Coordinator, All India Coordinated Research Project on Energy Requirements in Agric. Sector, College of Agric. Engg., Punjab Agric. Univ. Ludhiana, India

**T.P. Ojha**  
Dy. Director General, Indian Council of Agricultural Research, Krishi Bhawan, Dr. Rajendra Prasad Road, New Delhi-110001, India



A H Mirdha    O Ulloa-Torres    W J Chancellor    M R Goyal    A L Philips    S M Farouk    M A Mazed    Wang Wanjun    A M Michael    J.P. Mittal



T P Ojha S R Verma Soedjatmiko M Behrooz-Lar J Sakai B A Snobar C J Chung C C Lee Imad Haffar M Z Bardaie



M Afzal A D Chaudhry M S Chaudhry B T Devrajani A Q Mughal Surya Nath R M Lantin R P Venturina M H A Aziz S Illangantileke

**S.R. Verma**  
Dean, College of Agric. Engineering, Punjab Agricultural University, Ludhiana 141004, India (Presently; Chief Adviser to Head, National Centre for Agric. Mechanization, P.M.B. 1525, Ilorin, Nigeria)

**Soedjatmiko**  
Head of Subdirector of Agric. Engineering, Ministry of Agriculture, Jakarta, Indonesia

**Mansoor Behrooz-Lar**  
President, Iranian Society of Agricultural Machinery Engineers, P.O. Box 31585-574, Karaj, Iran

**Jun Sakai**  
Professor, Dept. of Agric. Engineering, Faculty of Agriculture, Kyushu University 46-05, Hakozaki, Higashi-ku, Fukuoka 812, Japan

**Bassam A. Snobar**  
Professor & chairman, Plant Production Dept., Faculty of Agriculture, University of Jordan, Amman, Jordan

**Chang Joo Chung**  
Professor, Dept. of Agric. Engineering, College of Agriculture, Seoul National University, Suweon, Korea 170

**Chul Choo Lee**  
Research Professor, Seoul Woman's University Mailing Address: Rm. 514 Hyundate Goldentel Bld. 76-3 Kwang Jang Dong, Sung Dong Ku, Seoul, Korea

**Imad Haffar**  
Assistant Professor of Agric. Mechanization, Dept. of Soils, Irrigation and Mechanization, Faculty of Agriculture and Food Sciences, American University of Beirut, Beirut, Lebanon

**Muhamad Zohadie Bardaie**  
Associate Professor, Faculty of Engineering, Universiti Pertanian Malaysia, 43400 UPM, Serdang, Selangor, Darul Ehsan, Malaysia

**Bala Krishna Shrestha**  
Agricultural Engineer, 4/141, Pulchowk Behind the Fire Brigade, Lalitpur, Nepal.

**Mohammad Afzal**  
Senior Engineer (Mechanization Engineer), Farm Machinery Institute, National Agric. Research Centre P.O. NIH, Islamabad, Pakistan

**Allah Ditta Chaudhry**  
Associate Professor & Charman, Dept. of Farm Machinery and Power, Agric. Engineering and Technology, University of Agriculture, Faisalabad, Pakistan

**Muhammad Siddique Chaudhry**  
280 Roger Williams Ave. #35 East Providence, R.I. 02916, U.S.A.

**Bherulal T. Devrajani**  
Principal Investigator, Sind Agriculture University, Tandojam, Sind, Pakistan

**A.Q. Mughal**  
Professor & Dean, Faculty of Agricultural Engineering, Sind Agriculture University, Tandojam, Sind, Pakistan

**Surya Nath**  
Lecturer II (Agric. Engineering) Dept. of Agriculture, University of Technology, Lae, Papua New Guinea

**Reynaldo M. Lantin**  
Agricultural Machinery Expert. Regional Network for Agricultural Machinery, c/o United Nations Development Programme P.O. Box 7285 ADC Pasay City Metro Manila, Philippines

**Ricardo P. Venturina**  
President & General Manager, Rivelisa Publishing House, 215 F. Angeles St. cor Taft Ave. Ext., 1300 Pasay City, Metro Manila, Philippines

**M.H. Abdel Aziz**  
Professor of Irrigation Engineering and Head, Agricultural Engineering Dept., Riyadh Univ., Saudi Arabia

**S. Illangantileke**  
Head, Dept. of Agric. Engineering, Faculty of Agriculture, University of Peradeniya, Sri Lanka

**Suppiah Kathirkamathamby**  
Head, Agricultural Engineering Research and Development Div., Dept. of Agriculture, Peradeniya, Sri Lanka

**Sen-Fuh Chang**  
Professor, Agric. Machinery Dept. National Taiwan University, Taipei, Taiwan.

**Chanchai Rojanasaroj**  
Research and Development Engineer, Dept. of Agriculture, Ministry of Agriculture and Cooperatives, Bang-Khen, Bangkok 10900, Thailand

**Gajendra Singh**  
Professor of Agric. Engineering, Div. of Agricultural & Food Engineering, Asian Institute of Technology, GPO 2754, Bangkok 10501, Thailand

**Yunus Pinar**  
Associate Professor, Agric. Engineering Dep., Faculty of Agriculture, University of Ondokuz Mayıs, Kurupelit, Samsun, Turkey

--- EUROPE ---

**Anastas Petrov Kaloyanov**  
Professor & Head, Research Laboratory on Farm Mechanization, Higher Institute of Economics, Sofia, Bulgaria

**Henrik Have**  
Prof. of Agric. Machinery and Mechanization at Institute of Agric. Engineering, Royal Veterinary- and Agricultural University, Agrovej 10 DK2630 Tastrup, Denmark

**Giuseppe Pellizzi**  
Director of the Institute of Agric. Engineering of the University of Milano and Professor of Agric. Machinery and Mechanization, Via G. Celoria, 2-20133 Milano, Italy

**Aalbert Anne Wanders**  
Staff Member, Dept. of Development Cooperation, Netherlands Agricultural Engineering Research Institute (IMAG), Wageningen, Netherlands

**John Kilgour**  
Senior Lecturer in Farm Machinery Design at Silsoe College, Silsoe Campus, Silsoe, Bedford, MK45 4DT, U.K. ■■



S Kathirkamathamby S F Chang C Rojanasaroj G Singh Y Pinar A P Kaloyanov H Have G Pellizzi A A Wanders J Kilgour

# BACK ISSUES

(Vol. 21 No. 1, Winter 1990 ~ )

<b>AGRICULTURAL MECHANIZATION IN ASIA, AFRICA AND LATIN AMERICA (Vol. 21, No. 1, Winter 1990)</b>			
Editorial (Y. Kishida) . . . . .	13	tion of RPS Marker-cum-USG Dispenser (R.V. Jadhav, N.L. Bote) . . . . .	17
Analysis of Tractor Test Procedure at the Nebraska Tractor Test Laboratory (B. Youren, L.I. Leviticus) . . . . .	15	Drag Force Analysis of Deep Placement Fertilizer Applicator for Rice (K.R. Alagusundaram, D.G. Clough, D.S. Jayas) . . . . .	21
Tractor ownership Costs (S.M. Ward) . . . . .	21	Comparative Performance of Hand Sprayers Using Different Application Techniques (M.R. Babu, G. Singh, C.P. Gupta) . . . . .	27
Effects of Plow Sole on Soil Infiltration Rate and Crop Yield in Irrigated Soil (A. Ahmed) . . . . .	24	Yam Tuber Resistance to Mechanical Damage (G.I. Nwandikom) . . . . .	33
Effect of Different Speeds on the Performance of Moldboard Plow (S. Bukhari, J.M. Baloch, G.R. Mari, A.N. Mirani, A.B. Bhutto, M.A. Bhutto) . . . . .	27	Mechanical Damage on Corn Kernel in Shelling Corn Ear (M. Nalbant) . . . . .	37
Evaluation of Puddling Treatments Using Animal-drawn Implements (R.B. Sharma) . . . . .	32	Design, Development and Evaluation of Castor Bean Sheller (V.M. Duraisamy, R. Manian) . . . . .	41
Selection of Seed-cum-Fertilizer Drill: Technical Consideration (A.S. Khan, M.A. Tabassum, J. Khan) . . . . .	35	Wear and Tear of Hard-surfaced Cultivator Shovel (A.H. Raval, O.P. Kaushal) . . . . .	46
Design and Development of Potato Grader (M. Shyam, V. Singh, R. Singh) . . . . .	40	Development of a Power-driven Sugarcane Detrasher (A.C. Srivastava, K. Singh) . . . . .	49
Performance Analysis of Ridge Profile Rotary Weeders (K.C. Oni) . . . . .	43	Determination of Food Grain Moisture Content by Microwave Heating (V. Saslokhe, S. Ilangantileke, A. Noomhorm) . . . . .	53
Total Milled and Head Rice Recoveries of Paddy as Influenced by its Physico-varietal Characteristics (C.J. Ancheta, S.C. Andales) . . . . .	50	Existing On-farm Grain Storage Facilities in Nigeria and Suggested Improvements (B.R. Birewar) . . . . .	58
The Theory of Free Cutting and its Application on Cotton Stalk (E. Güzel, Y. Zeren) . . . . .	55	Design and Development of a Hand-operated Feed Mixer (S. Nath, A.H.D. Anyangu) . . . . .	61
Adapting a Hand Mill to Hull Rice and Spelt Wheat (A. Dong, R.J. Edberg) . . . . .	57	Development of Process and Equipment for Soyflakes in India's Rural Areas (R.T. Patil, B.D. Shukla, A.P. Gandhi) . . . . .	65
Comparative Study of Agricultural Mechanization in India and Indonesia (B.G. Yadav, H. Suryanto) . . . . .	59	Power Tiller Potential in Forestry (A.C. Varshney, D.C. Saxena, S. Narang) . . . . .	71
Utilization of Solar Energy with Far-infrared Rays for Drying Animal Feed (Z. Sheng-yu) . . . . .	67	A Single-board Computer-based Data Acquisition System for Agricultural Machinery Evaluation (N.P. Thomas) . . . . .	73
Nile Water Resources of the Sudan: Present and Future Utilization (H.A.A. Rahman) . . . . .	69	Machine Intelligence Application in Agriculture (M. Afzal) . . . . .	77
The Present State of Farm Machinery Industry (Farm Machinery Industrial Research Corp.) . . . . .	74	Abstracts . . . . .	81
Prospect of the Institute of Agricultural Machinery in Japan (Planning Dept., IAM, BRAIN) . . . . .	79	New Products . . . . .	85
Research and Development of Agricultural Machinery in Japan (O. Kitani) . . . . .	84	Book Review . . . . .	87
Farming Structures and Trends of Agricultural Mechanization in Japan (J. Sakai) . . . . .	89		
Technical Cooperation of Agricultural Machinery in Japan (T. Tsujimoto) . . . . .	96	<b>AGRICULTURAL MECHANIZATION IN ASIA, AFRICA AND LATIN AMERICA (Vol. 21, No. 3, Summer, 1990)</b>	
Name and Address . . . . .	103	Editorial (Y. Kishida) . . . . .	7
Abstracts . . . . .	115	Field Performance Tests of Turtle Tiller and Boat Tractor (D. Geecough, S. Palaniappan, R.B. Gavino) . . . . .	9
News . . . . .	118	Research on Water Saving on Sandy Soil in Drip Irrigation (I) (A.R. Shajari, M. Gueye, J. Yonemura, A. Sasao) . . . . .	13
Book Review . . . . .	120	Performance of Two Different Types of Combines in Harvesting Rice in Egypt (H.A. Fouad, S.A. Tayel, Z. El-Hadad, H. Abdel-Mawla) . . . . .	17
		Performance Evaluation of Chickpea Thresher in Pakistan (M.T. Anwar, C.P. Gupta) . . . . .	23
		Development and Performance Evaluation of Pedal-operated Sunflower Thresher (R.V. Jadhav, J.S. Deshpande) . . . . .	29
		Development and Performance Evaluation of a Sorghum Thresher (K. Desta, T.N. Mishra) . . . . .	33
		Development of Power-operated Groundnut Sheller (k. L. Gore, C.P. Gupta, G. Singh) . . . . .	38
		Bin-drying Shelled Corn with Natural Air in Beijing, China (X. Yang, C.J. Bern, D.L. Williams) . . . . .	45
		Thermal Energy Storage in Concrete and Mud for Crop Storage (E.A. Baryeh) . . . . .	48
		Physical Properties of Peanut in Turkey (I.D. Akcali, O. Guven) . . . . .	55
		Relationship between Observed and Estimated Crop Evapo-transpirations (O. Hussain, P.M. Mushabbir, F. Christoph) . . . . .	61
		Technology Transfer - An Experience at CIAE, Bhopal, India (G. Singh) . . . . .	66
		Technical Considerations in Agro-based Project Planning and Evaluation (F.I. Idike, E.U. Odigboh) . . . . .	73
		Agricultural Mechanization at a Crossroad in Nigeria (S.G. Nwoko) . . . . .	79
		Design and Development of a Tractor-drawn Automatic Sugarcane Planter (M.P. Sharma, K. Singh) . . . . .	83
		News . . . . .	86
		Book Review . . . . .	87
		<b>AGRICULTURAL MECHANIZATION IN ASIA, AFRICA AND LATIN AMERICA (Vol. 21, No. 4, Autumn, 1990)</b>	
		Editorial (Y. Kishida) . . . . .	7
		Development of Auger Digger as Attachment to Power Tiller (K. Kathirvel, T.V. Job, R. Karunanithi, K.R. Swaminathan) . . . . .	9
		Dual-mode All-crop Thresher for Egyptian Conditions (A.U. Khan) . . . . .	11
		Development and Testing of a Power-operated Wheat Thresher (B.K. Behera, S.K. Dash, D.K. Das) . . . . .	15
		Comparative Cost of Shallow Tubewell Irrigation Using Diesel Engines and Electric Motors (T.N. Datta) . . . . .	22
		Research on Water Saving on Sandy Soil in Drip Irrigation (II) (A.R. Shajari, M. Gueye, J. Yonemura, A. Sasao) . . . . .	25
		Development and Testing of Pedal-cum-Power Operated Air Screen Grain Cleaner (R.P. Kachru, K.M. Sahay) . . . . .	29
		Utilization of Wind Power and Wetted Pads to Evaporatively Cool Dairy Cow Sheds under Hot and Arid Climatic Conditions (A.M. Abdalla, R. Narendran) . . . . .	33
		Microcomputer Simulation of Heat Transfer in Tropical Swine Housing (I.A. Nass, F.S. Zazueta, R.A. Bucklin) . . . . .	38
		A Quality Control Model for Oil Palm Fresh Fruit Bunches (E. Meshack-Hart, A. Srivastava) . . . . .	43
		Watering Requirement and Scheduling of Date Palm (A.B. Saeed, H.A. Etewy, O.S. Hassan) . . . . .	49
		Design Specification of a Date Palm Service Machine (S.A. Al-Suhaibani, A.S. Babaeir, J. Kilgour) . . . . .	53
		Friction Coefficient of Cereal Grains on Various Surfaces (L.O. Gumbe, C. Maina) . . . . .	61
		Utilization Pattern of Farm Machinery and Farm Mechanization in Korea (W. Park) . . . . .	65
		Production of Amorphous Silica from Rice Husk in a Vertical Furnace (A. Chakraverty, H.D. Banerjee, P. Mishra) . . . . .	69
		Optimum Farm Planning by Linear Programming for Tarai Belt of Nepal (V.M. Salokhe, M.P. Pariyar) . . . . .	76
		Analysis of Problems of Agricultural Mechanization in Pakistan (A. Razzaq, M.A. Malik, B. Sabir) . . . . .	81
		News . . . . .	85
<b>AGRICULTURAL MECHANIZATION IN ASIA, AFRICA AND LATIN AMERICA (Vol. 21, No. 2, Spring 1990)</b>			
Editorial (Y. Kishida) . . . . .	7		
Effect of Implement and Soil Parameters on Penetration Depth of a Disc Plow (B. Panigrahi, J.N. Mishra S. Swain) . . . . .	9		
Influence of Manual and Tractor-drawn Tillage Tools on Soil Properties and Tomato Yield (J.S. Adeoti, J.D. Olarewaju) . . . . .	13		
Design Development and Field Evaluation			

**AGRICULTURAL MECHANIZATION IN ASIA, AFRICA AND LATIN AMERICA** (Vol. 22, No. 1, Winter, 1991)

Editorial (Y. Kishida) . . . . . 13  
 Development of Load Cell of Tension and Compression Type by Appropriate Technology (Y. Shibata, K. Toyoda) . . . . . 15  
 Feasibility of Using Field Plot Machinery in India (B.G. Yadav, R.N.S. Yadav) . . . . . 21  
 Testing and Evaluation of Fuel Filters Used on Tractors (A.K. Singh, M.L. Mehta, R. Tiwari) . . . . . 26  
 Field Performance Evaluation of Bullock-drawn Puddler (D.N. Sharma, M.L. Jain, S.C.L. Premi) . . . . . 29  
 Power Requirements of Tillage Implements (J. M. Baloch, S.N. Mirani, A.N. Mirani, S. Bukhari) . . . . . 34  
 Design, Development and Evaluation of Power Tiller-drawn Seed-cum-Fertilizer Drill (A.C. Varshney, C.P. Bohra, S. Narang) . . . . . 39

Small Power Unit, Equipment and Service Units - Needs, Structures and Problems (L.G. Stoimenov) . . . . . 42  
 Development of a Low-cost Weeder for Lowland Paddy (Md. S. Islam, K.A. Haq) . . . . . 45  
 Energy Studies in Cropping Systems in Lateritic Soil of Orissa, India (P.K. Mohapatra, P.C. Senapati, D. Satpathy) . . . . . 49  
 Rice Post-harvest Practices and Loss Estimates in Bangladesh: Threshing through Sundrying (A.K.M.A. Haque, N.H. Choudhury, M.A. Quasen, J.R. Arboleda) . . . . . 53  
 Energetics of Forage Chopping (Y. Jekendra, P. Singh) . . . . . 59  
 Mango Harvesting Techniques in Bangladesh (D. Hussain, M. Alam, Md. A. Hussain) . . . . . 64  
 Agricultural Mechanization in Rajasthan, India (A. K. Sharma) . . . . . 69  
 For Emitters as Evaporative Cooling Devices for Dairy Cow Sheds (A.M. Abdalla, R. Narendran) . . . . . 73

The Present State of Farm Machinery Industry (F.M.I.R. Corp.) . . . . . 77  
 Outline and Activities of National Agriculture Research Center (T. Kuwana) . . . . . 81  
 Prospect of Agricultural Machinery Course in Hokkaido University (Hokkaido University) . . . . . 86  
 Research and Education of The University of Tsukuba (T. Konaka) . . . . . 89  
 Introduction of Agricultural Machinery Laboratory, Department of Agricultural Engineering, Kyushu University (J. Sakai) . . . . . 91  
 Japanese Society of Agricultural Machinery (T. Konaka) . . . . . 96  
 Activities by Hokkaido Agricultural Machinery Assoc. (N. Murai) . . . . . 99  
 Main Products of Agricultural Machinery Manufacturers in Japan (Shin-Norinsha Co., Ltd.) . . . . . 101  
 News . . . . . 106  
 Book Review . . . . . 110

## AMA ABSTRACTS AND INDEX, 1971-1980

— A Key to Wealth of Information —

As the AMA enters its 13th year of publication this year, the Editorial Staff deems it appropriate to commemorate the event by publishing "Abstracts and Index 1971-80" in May, 1983 for only ¥2,000 a copy, including sea mail postage.

During the decade 1971-1980, more than a thousand articles were received by AMA from readers and co-editors. Over 600 of these contributions were published from which the abstracts and index in various aspects of agriculture and agricultural mechanization in developed and developing countries were arranged for use as a handy reference by students, government officials, researchers and academicians interested in agriculture and agricultural mechanization. For example, at a glance, the abstract and index tell about the content of the article, author and AMA issue number. The publication form is A3 size (18.5 cm x 21 cm) 82 pages.

A limited number of copies are still available for which reason they will be sold on a first-come, first-served basis. In order that interested readers get their copies of the publication, it will be very useful for them (and convenient for the AMA Staff) to fill up the order form inserted in this issue and mail it to —

**FARM MACHINERY INDUSTRIAL RESEARCH CORP.**

7-2 Kanda Nishikicho, Chiyoda-ku, Tokyo, Japan (Tel. 03/291-5717-8, 3671-4)

# VALIANT TEA HARVESTER

## MCT10



A Dependable Way of Making Tea Harvesting a Lot Easier

### Features

- Picks Best Quality Leaves
- Simple Operation; High Efficiency; Economy
- Unique Design; Sturdy Construction; Long Life
- Simple Design and Easy Operation
- Crawler Type; Good Maneuverability



## MST-E2

### Features

- Picks Best Quality Leaves with High Efficiency
- Unique Design; Long Life
- Simple and Easy Operation
- Self-propelling; Labor-saving



# MATSUMOTO KIKO CO.,LTD

Head Office: 9325, MAKINOCHI, EI-CHO, IBUSUKI-GUN, KAGOSHIMA-PREF:JAPAN

TEL.0993(36)1161 FAX.0993(36)2829



# THINKING AND THINKING, MORE THAN 89 YEARS

# Sasaki

When turn around ourselves, it was absorbed for the development and research since we established in 1901.

**FROM NOW ON** ..... We would like to pay our full effort for the development of the new tractor implement to meet various requirement and speed sprayer.

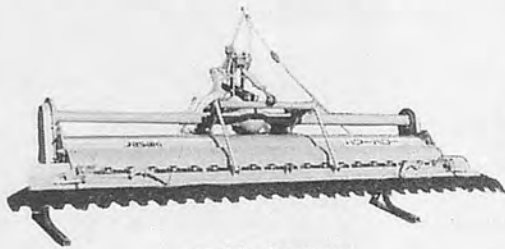

paddy harrow



fertilizer spreader



speed sprayer

## SASAKI CORPORATION

HEAD OFFICE & FACTORY SATONOSAWA TOWADA AOMORI JAPAN FAX (0176)22-8607

We want to supply only chassis  
with gear-box and rubber belts  
for your convenience.

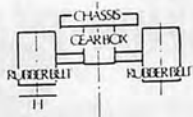
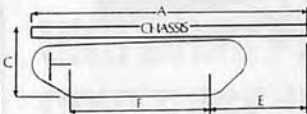
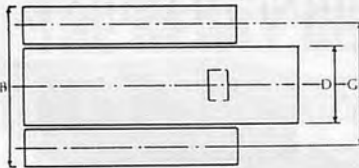

	M7B	M900	S100	HM-10	HM-1000	KM2	CM152	CM2001
<b>A</b>	1330	1420	1630	1970	2220	1855	2275	2750
<b>B</b>	680	850	980	960	1100	1260	1430	1800
<b>C</b>	336	366	401	406	440	366	416	476
<b>D</b>	240	410	540	414	450	720	720	850
<b>E</b>	395	500	465	635	640	730	840	875
<b>F</b>	756	720	918	1085	1300	1100	1200	1740
<b>G</b>	480	650	780	710	800	1010	1100	1350
<b>H</b>	200	200	200	250	300	250	330	450
<b>ENGINE (PS)</b>	5	5	5	7	9	12	12	22
<b>GEAR-BOX (i)</b>	(F1)0.0479 (F2)0.0961 (R)0.0359	(F1)0.0479 (F2)0.0961 (R)0.0359	(F1)0.042 (F2)0.0806 (F3)0.119 (R)0.036	(F1)0.0463 (F2)0.0909 (F3)0.147 (R1)0.0444 (R2)0.0877 (R3)0.141	(F1)0.0358 (F2)0.077 (F3)0.148 (R1)0.0341 (R2)0.0735 (R3)0.142	(F1)0.0491 (F2)0.102 (F3)0.204 (R)0.0506	(F1)0.049 (F2)0.102 (F3)0.204 (R)0.0506	(F1)0.0219 (F2)0.0423 (F3)0.077 (R)0.0219

**SUNWA SHARYO MFG. CO., LTD.**  
571 Negishi, Sayama, Saitama 350-13, Japan Phone: 0429 (54) 6611  
FAX: 0429 (54) 6617

# THE COMPLETE BUNMEI SYSTEM FOR YOUR SUGARCANE HARVESTING NEEDS !

OFFERING A COMPLETE SERIES OF HARVESTING MACHINES  
FROM THE WALKING TYPE TO THE RIDING TYPE.



THE SMALL WALKING TYPE  
HARVESTER OPERATION SCENE



THE SMALL LEAF STRIPPING MACHINE  
(KC-2 MODEL)



THE RIDING TYPE HARVESTER  
OPERATION SCENE



THE SMALL WALKING TYPE  
HARVESTER (NB-11)



THE MINI DRUM LEAF STRIPPING  
MACHINE (MDG-8 MODEL)



THE RIDING TYPE HARVESTER  
(NB-15T)



**BUNMEI NOKI CO., LTD.**

11-4, 1-Chome, Korimoto-cho,  
Kagoshima-city, 890 Japan.  
Tel.0992(54)5121 Fax.0992(57)6676

## VEGETABLE WASHER BY "CHIKUSHI-GO"

JAPAN'S BEST SELLING  
RADISH WASHING MACHINE

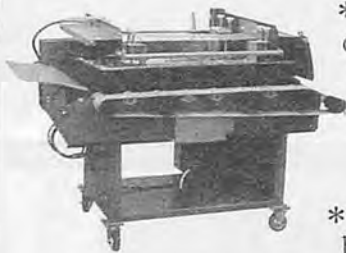

- \* Symmetrical construction enables two-way operation.
- \* Flat brush made of stainless sheet.
- \* Easy maintenance. by one-touch button.

SWEET POTATO  
WASHING MACHINE



- \* Usable to washing/polishing of sweet potato, potato, melon, tomato and eggplant.
- \* Uniform washing thanks to spring-loaded brushes.

CARROT WASHING MACHINE



- \* Applicable to washing carrot, burdock and taro.
- \* Wide outlet opening helps easy handling.
- \* Nine rolling brushes assure high efficiency.

PUMPKIN/MELON  
POLISHING MACHINE

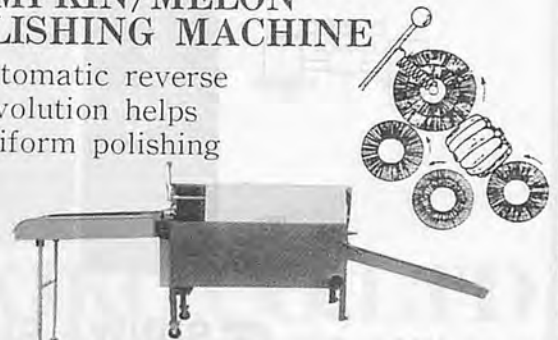

- \* Automatic reverse revolution helps uniform polishing



**CHIKUSHIGO CO., LTD.**

29-3, Ino Oaza Umi-machi Kasuya-gun Fukuoka-pref.  
Japan TEL.092(932)1662 FAX.092(933)5787

# NOZAWA's Advanced Power Transport Vehicles!



## Trac-Lift CF-Series "Fruitsworker"

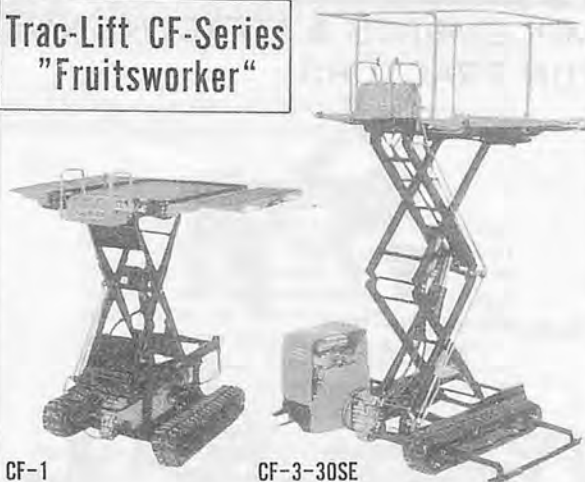

CF-1

CF-3-30SE

The operator can manipulate ups-and-downs of The platform and forward-and-back motion of the vehicle from his working position. This feature greatly improves the working efficiency.

## NOZAWA MANUFACTURING CO., LTD.

224-1, Naganuma-cho, Iseaki-shi, Gunma-ken, Japan  
TEL. 0270(32)1315 FAX. 0270(32)7537

The Arimitsu greenhouse sprayer delivers uniform ultra fine particles resulting in superior coverage on upper and lower leaf surfaces.

## THE NEWLY DESIGNED VENT TUBE DELIVERY SYSTEM OFFERS BETTER UNIFORMITY OF SPRAY COVERAGE IN DENSE PLANT FOLIAGE



**Arimitsu originated this forced air convection system.**

The air flow from the fogger unit establishes a convection pattern in the greenhouse. The nozzle emits micron sized particles of spray material into this air flow pattern which circulates it throught the greenhouse environment during the designated time of application.

As application progresses, the micronized particles increase in density in the entire greenhouse environment.

 **ARIMITSU INDUSTRY CO., LTD.**

3-21, Fukaekita 2 chome, Higashinari-ku  
OSAKA, 537 JAPAN

Phone:(06)973-2030 Telex:0-529-7257 ARIMIT J Fax:(06)976-1031

## SUKIGARA CULTIVATOR & RIDGER

IMPLEMENTS & ATTACHMENTS  
FOR TRACTORS



Double-Row Cultivator TBC  
(Tool Bar & Cultivator)



Triple-Row Ridger TCRM

Double-Row Ridger TBR-2B  
(Tool Bar & Ridger)

**SUKIGARA AGRICULTURAL MACHINERY CO., LTD.**

YAHAGI-CHO, OKAZAKI-CITY, AICHI PREF., 444 JAPAN  
TEL OKAZAKI (0564)31-2107  
FAX (0564)32-1990(G2)  
CABLE ADDRESS: "SUKIGARA" OKAZAKI, JAPAN

## TIGER KAWASHIMA THE PROFESSIONAL MANUFACTURER OF CEREAL GRADER



● THE PACKMATE PROVIDES YOU WITH GRADING, AUTOMATIC WEIGHING, AND PACKAGING OF EITHER RICE, WHEAT OR BARLEY, ALL IN A SINGLE UNIT.

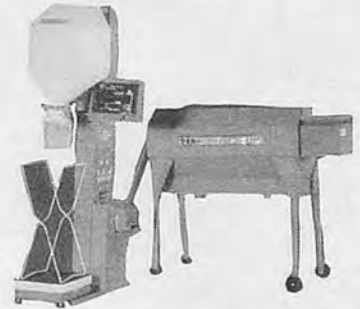

● TIGER KAWASHIMA PRODUCTS COMBINE ACCURACY AND EASY OPERATION BY USE OF STATE-OF-THE-ART COMPUTER TECHNOLOGY. JUST ABOUT ANYONE CAN USE THEM.

● THE RICE COMBI AND GRADER COMBINATION, PROVIDING A CEREALS (RICE, WHEAT, BARLEY) GRADER AND AN IC-TECH COMBI FOR AUTOMATIC WEIGHING AND PACKAGING.

**TIGER KAWASHIMA CO., LTD.**

4290, Fujioka, Fujioka-cho, Shimostuga-gun,  
Tochigi-prefecture, 349-13 JAPAN.

# MARUSHICHI RICE WHITENING MACHINE

ECHO-STAR M-5 180~240kg/h

ECHO-STAR M-3 360~480kg/h

Double jet suction mechanism.

Low breakage rate and power.

### Specifications

Model	Power kW	Capacity kg/h	Size: H×W×L, mm
M-3*	2.2	180-240	1,170×470×520
M-3**	2.2	180-240	930×470×520
M-5*	3.5	360	1,250×475×675
M-5*	5.5	480	1,250×475×675
M-5**	3.5	360	955×475×675
M-5**	5.5	480	955×475×675

\* With built-in motor; \*\* ordinary type.

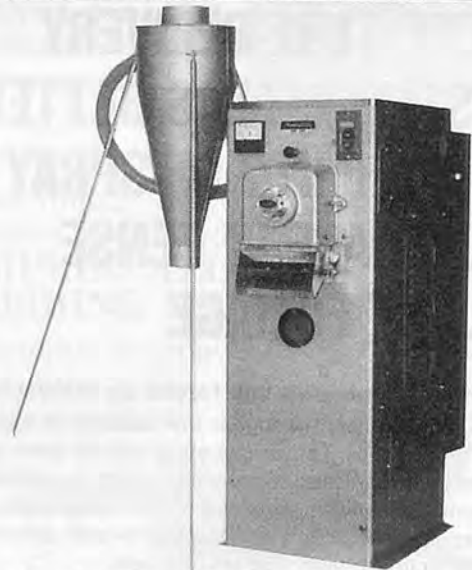

**MARUSHICHI CO., LTD.**

1-23-2, SENJU, ADACHI-KU, TOKYO 120 TEL: 03(3879)5191 FAX: 03(3879)5194

# INSTRUCTIONS TO AMA CONTRIBUTORS

The Editorial Staff of the AMA requests contributors of articles for publication to observe the following editorial policy and guidelines in order to improve communication and to facilitate the editorial process :

## Criteria for Article Selection

Priority in the selection of articles for publication is given to those that –

- a. are written in the English language ;
- b. are relevant to the promotion of agricultural mechanization, particularly for the developing countries ;
- c. have not been previously published elsewhere, or, if previously published are supported by a copyright permission ;
- d. deal with practical and adoptable innovations by small farmers with a minimum of complicated formulas, theories and schematic diagrams ;
- e. have a 50 to 100-word abstract, preferably preceding the main body of the article ;
- f. are typewritten, double-spaced, under 4,000 words (approximately equivalent to 8 pages of AMA-size paper) ; and those that
- g. are supported by authentic sources, reference or bibliography.

## Rejected/Accepted Articles

- a. As a rule, articles that are not chosen for AMA publication are not returned unless the writer(s) asks for their return and are covered with adequate postage stamps. At the earliest time possible, the writer(s) is advised whether the article is rejected or accepted.
- b. When an article is accepted but requires revision/modification, the details will be indicated in the return reply from the AMA Chief Editor in which case such revision/modification must be completed and returned to AMA within three months from the date of receipt from the Editorial Staff.
- c. "The AMA does not pay for articles published. However, the writers are given collectively 5 free copies (one copy air-mailed and 4 copies sent by surface/sea mail) of the AMA issue wherein their articles are published. In addition, a single writer is given 25 off-prints of the article and plural writers are given 35 off-prints (also sent by surface/sea mail)"

## Procedure

- a. Articles for publication (original and one-copy) must be sent to AMA through the Co-operating Editor in the country where the article originates. (Please refer to the names and addresses of Co-operating Editors in any issue of the AMA). However, in the absence of any Co-operating Editor, the article may be sent directly to the AMA Chief Editor in Tokyo.
- b. Contributors of articles for the AMA for the

first time are required to attach a passport-size ID photograph (black and white print preferred) to the article. The same applies to those who have contributed articles three years earlier. In either case, ID photographs taken within the last 6 months are preferred.

- c. The article must bear the writer(s) name, title/designation, office/organization, nationality and complete mailing address.

## Format/Style Guidance

- a. Whether the article is a technical or popular contribution, lecture, research result, thesis or special report, the format must contain the following features :
  - i) a brief and appropriate title ;
  - ii) the writer(s) name, designation/title, office/organization ; and mailing address ;
  - iii) an abstract following ii) above ;
  - iv) body proper (text/discussion) ;
  - v) conclusion/recommendation ; and a
  - vi) bibliography
- b. The pages must be numbered (Arabic numeral) successively at the top center. Tables, graphs and diagrams must likewise be numbered. Table numbers must precede table titles, e.g., "Table 1. Rate of Seeding per Hectare". Such table number and title must be typed at the top center of the table. On the other hand, graphs, diagrams, maps and photographs are considered figures in which case the captions must be indicated below the figure and preceded by number, e.g., "Figure 1. View of the Farm Buildings".
- c. Tables and figures must be preceded by texts or discussions. Inclusion of such tables and figures not otherwise referred to in the text/discussion must be avoided.
- d. Tables must be typed clearly without vertical lines or partitions. Horizontal lines must be drawn only to contain the sub-title heads of columns and at the bottom of the table.
- e. Express measurements in the metric system and crop yields in metric tons per hectare (t/ha) and smaller units in kilogram or gram (kg/plot or g/row).
- f. Indicate by footnotes or legends any abbreviations or symbols used in tables or figures.
- g. Convert national currencies in US dollars and use the later consistently.
- h. Round off numbers, if possible, to one or two decimal units, e.g., 45.5kg/ha instead of 45.4762kg/ha.
- i. When numbers must start a sentence, such numbers must be written in words, e.g., Forty-five workers . . . , or Five tractors . . ." instead of 45 workers . . . , or, 5 tractors.

**OCHIAI** is the top-ranking tea-leaf picker manufacturer in Japan. **OCHIAI**'s products are used in tea-producing areas worldwide.

*OMS-2* Riding type pest control machine

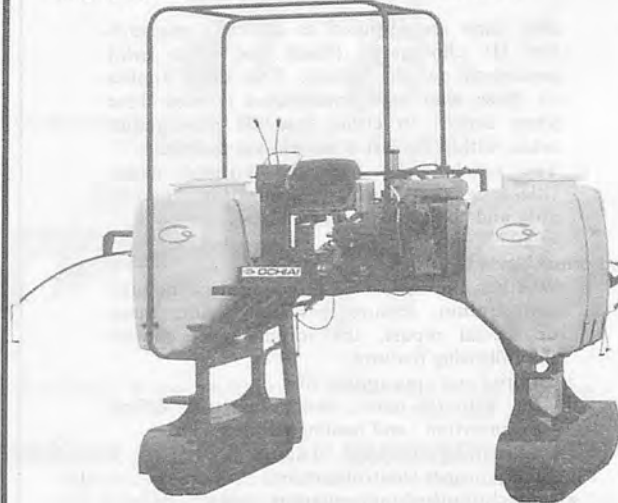

*V8-NEWZ* tea picker

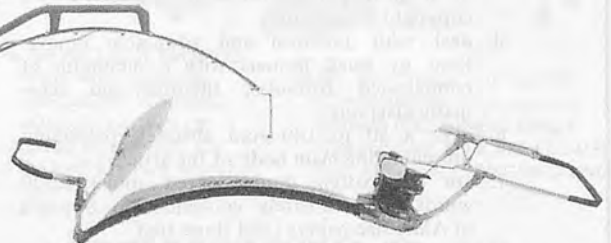

*R8* tea pruning machine

## HIGH-EFFICIENCY RIDING TYPE SERIES

*OM-25* Full-width tea picker



*E-7AT-750*  
Engine tea-tree trimmer

### GUIDE TO OCHIAI

- Succeeded in devising Japan's first automatic tea-leaf picker in 1959.
- Received the Director of the Board of Scientific Technology Award in 1967.
- During the intervening period (1959-1967) obtained a number of patents, as well as receiving a variety of awards and prizes in the domain of science and technology.
- The top-ranking tea-leaf picker and tea-tree trimmer producer, holding 60% of the shares in the same line of business in Japan, surpassing the other manufacturers in sales and product, and leading the related business worlds in its expansion and development.



**OCHIAI-SHOJI CO., LTD.**

Head Office : 58, Nishikata, Kikugawa-cho, Ogasa-gun, Shizuoka-ken, Japan  
Tel. Kikugawa (05373) 6-2161-5 Telex 03965824 STPA J ATTN OCHIAI

# MAMETORA DEDICATES TO AGRICULTURE ALL OVER THE WORLD

Researches and Development  
Unequaled Wealth of  
experiences and  
technology

It is the motto of MAMETORA that we manufacture goods in order to meet customer's benefits with originality trusty and hearty. In addition to the head office in Okegawa Kisakata Factory has been established. Now that we have formed the much steadier basis as a comprehensive manufacturer. We are always making efforts to manufacture goods of high quality and are pleased to devote ourselves to the food industry in the world as well as that in Japan.

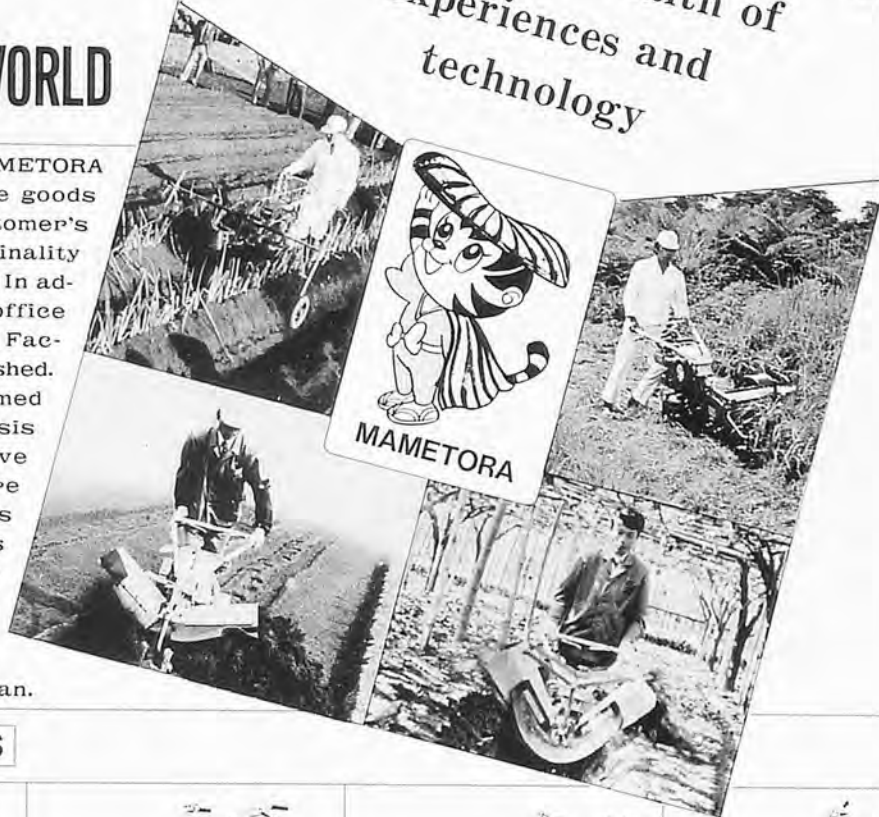

## EXPORT SERIES

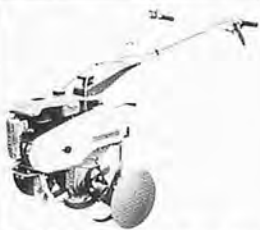

MC-80R Mulching Rotor Set



MC-100



MC-130E



MC-181SB



MC-200



MC-210 スキ付



LV-1



LV-2

## MAMETORA AGRIC. MACHINERY CO., LTD.

HEAD OFFICE ADD : 9-37, NISHI-2 CHOME, OKEGAWA-SHI, SAITAMA-KEN, JAPAN.  
TELEPHONE : 0487-71-1181      TELEX : 2922561 MAMETO-J

