

*International specialized medium for agricultural mechanization in developing countries*

ISSN 0084-5841

# AMA

**AGRICULTURAL MECHANIZATION IN ASIA, AFRICA AND LATIN AMERICA**

VOL.51, NO.4, AUTUMN 2020

---

## **AMA 50<sup>th</sup> Anniversary Special Edition: SDGs and Agricultural Mechanization**

**FARM MACHINERY INDUSTRIAL RESEARCH CORP.**



KUBOTA Corporation

For Earth, For Life  
**Kubota**



# Beyond 130

Since 1890, Kubota has been in business in the areas of Food, Water, and the Environment. With 130 years of our spirits and footsteps, we continue to go forward for a brighter future for the Earth and humanity.

**KUBOTA Corporation**

**For Earth, For Life**  
**Kubota**



## Leading Implement Manufacturer

Since its establishment in 1902, Matsuyama has devoted every effort to the development of its own technology to design the machines fertilizing the soil.

Matsuyama provides wide range of products from tiller to potato harvester and grass mower.

Matsuyama is the leading implement manufacturer in Japan.

Customer's viewpoint, safety, long lifetime, and ease of use : those are what Matsuyama has been seeking since its establishment.



**Niplo Grand Rotary**  
rotary tiller



**Niplo Wing Harrow**  
paddy harrow



**For the human** We produce useful functions for the human



Future of the Earth with Nature

## Niplo Levee Plastering Machine



## Niplo Speed Culti cultivator



**Niplo Sarf Rotary**  
rotary tiller



**Niplo Broadcaster**



**Niplo Slide Mower**

# MATSUYAMA PLOW MFG. Co., LTD.

Head Office & Factory : 5155, Shiokawa, Ueda-shi, Nagano-ken, 386-0497, Japan  
Telephone : +81-268-42-7504 Fax : +81-268-42-7528 <https://www.niplo.co.jp>

# MAMETORA DEDICATES TO AGRICULTURE ALL OVER THE WORLD

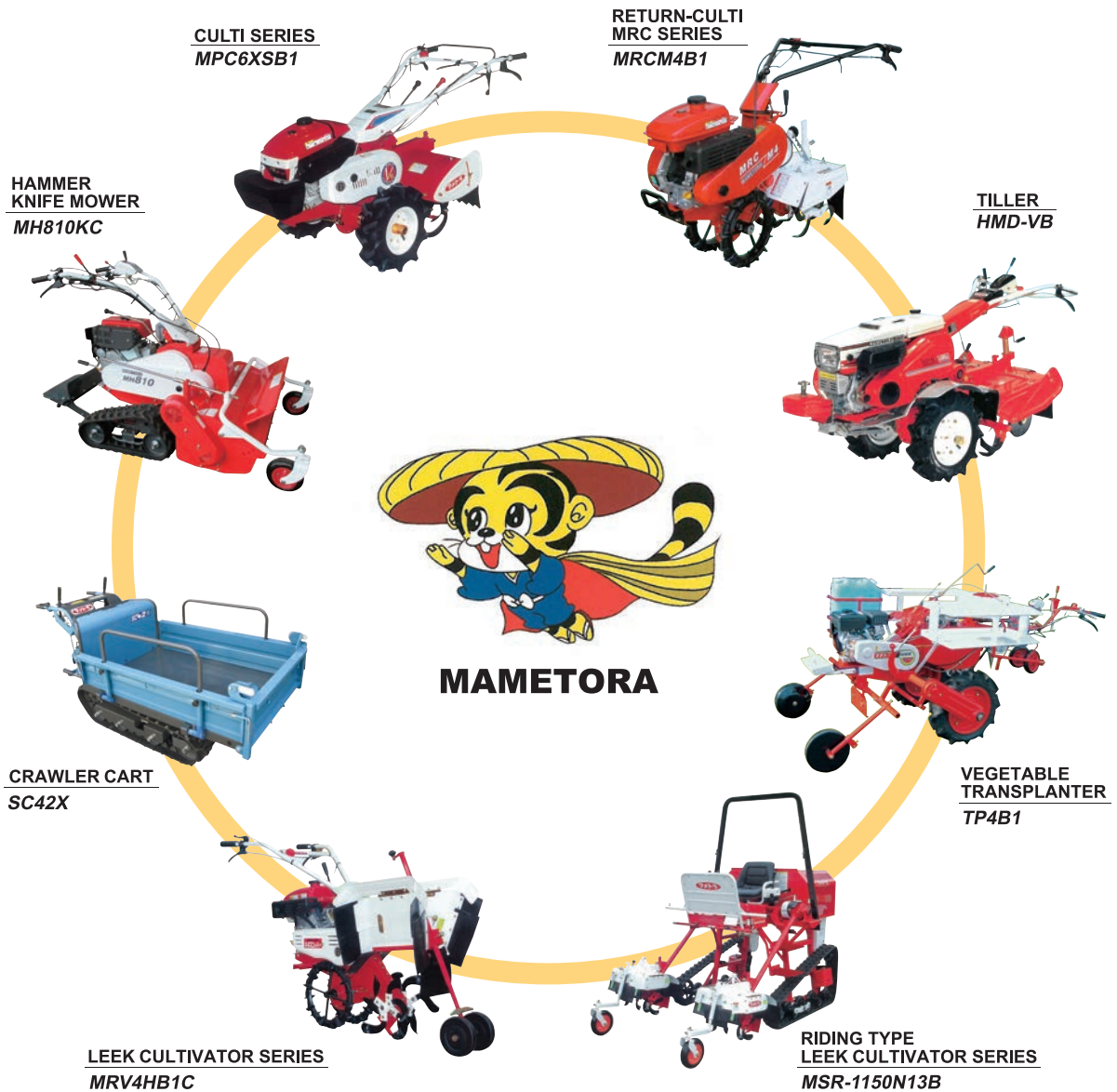

**MAMETORA AGRIC. MACHINERY CO., LTD.**

.....

It is the motto of MAMETORA that we manufacture goods in order to meet customers' benefits with originality, trust and heart. In addition to the head office in Okegawa, Kisakata Factory has been established. Now that we have formed much steadier basis as a comprehensive manufacturer. We are always making efforts to manufacture goods of high quality and are pleased to devote ourselves to the food industry in the world as well as that in Japan.

.....

## Full face slope alert

# MAME ALERT

The buzzer goes off when the tilt angle of your machine reaches 15-20°!



**MAT-15** (15° and over) / **MAT-2** (20° and over)



- Prevents your machine from toppling over
- Keeps the surface of gasoline engine oil level
- Warns about an abrupt steering

HEAD OFFICE : 2-9-37, NISHI, OKEGAWA-SHI, SAITAMA-KEN 363-0017 JAPAN

TEL: +81-48-771-1181 FAX: +81-48-771-1529 URL: <http://www.mametora.co.jp> E-mail: [info@mametora.co.jp](mailto:info@mametora.co.jp)

**Professionals use grain dryers designed for produce quality grain.**

Kaneko products use low temperature to provide even and speedy drying, produce high quality grain, bring you the highest profit and income.

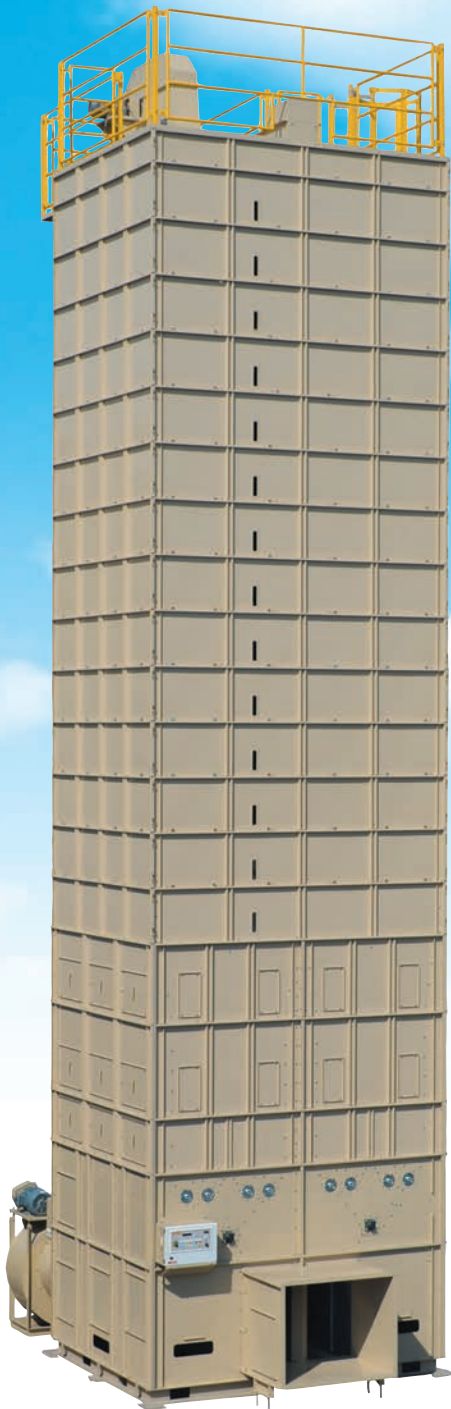

**GRAIN DRYER**  
Size : 10,000~30,000kg  
(Paddy Rice)



**FLATBED DRYER**  
Capacity : 3.1~6.2m<sup>3</sup>



**RICE HULLER**  
Power : 1,320~1,920kg/h



**LOADING CHAIN CONVEYOR**  
Power : 10~50t/h



## RICE DRYING COMPLEX (Basic Layout)

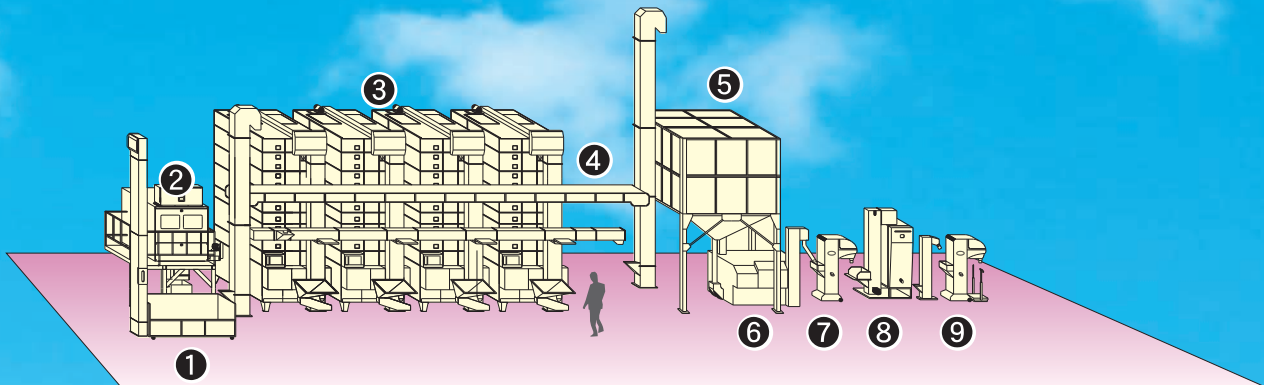

- ① Hopper ② Precleaner ③ Grain Dryer ④ Loading Chain Conveyor
- ⑤ Dried Grain Silo ⑥ Rice Huller ⑦ Rice Sorter ⑧ Color Sorter
- ⑨ Weighing Machine



**KANEKO AGRICULTURAL MACHINERY CO.,LTD.**

Head Office:516-10,Komatsudai 1-choume,Hanyu, Saitama 348-8503 Japan

TEL: +81-48-561-2111 FAX: +81-48-563-1577

URL <https://www.kanekokk.co.jp/> E-mail [info@kanekokk.co.jp](mailto:info@kanekokk.co.jp)



# MOROOKA TECHNOLOGY to WORLDWIDE JOBSITE HST SYSTEM AND RUBBER CRAWLER

MOROOKA developed Rubber Crawler about 40 years ago with joint development with Bridgestone. Rubber Crawler provides high performance even on irregular ground, stable moving on the sloping ground or snowy land.

**Team MOROOKA HeLps You ! Here's Experts in Each Field !!**



**Best Buddy in Muddy Fields  
Tough and stable Rubber Crawler Forklift**



**Powerful and Invisible Hero  
Carrier Dump for a large amount**



**For fertilizer  
transportation**



**For sugar cane plant  
transportation**



**For potato  
transportation**

## Specialties of MOROOKA Products

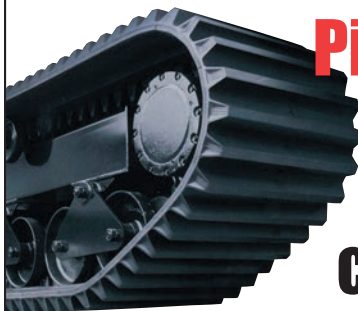

**Pioneer  
of the  
rubber  
crawler**

- Seamless and durable rubber crawler assures high performance movement with low ground pressure.
- Simple and compact design allows easy operation for everybody.
- Ship structure underbody and rotary bogie system absorb the impact and allow the stable movement.
- Rubber crawler is used as base body of wide range of industrial machines.
- Rubber crawler and HST (hydrostatic transmission) system enables easy control for smooth & stable movement and huge driving power.

### For forestry



**ROTARY SCREEN**



**FORWARDER**



**MOBILE  
WOOD CRUSHER**

### For agriculture and multipurpose



**FORKLIFT**



**SHOVEL LOADER**



**CARRIER**

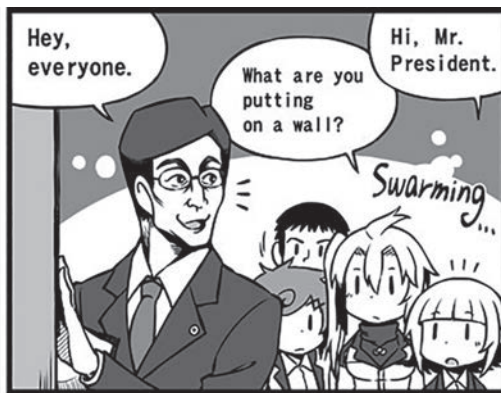

**Morooka's Initiatives**

ESG	<b>Environment</b> <ul style="list-style-type: none"> <li>Acquired ISO14001 in 2012 and implemented a company-wide environmental management</li> <li>Promoting the use of renewable energy by solar power generation</li> <li>Contribute to the preservation of the global environment through our principal business, by developing wood crushers and promoting recycling of waste wood</li> </ul>	7 13 15
	<b>Social</b> <ul style="list-style-type: none"> <li>Announcing the declaration of work style reform and actively promoting measures such as shortening working hours and promoting paid leave</li> <li>To promote the health of our employees, we have declared ourselves as a health and productivity management company and aim to be certified as an "Excellent Health and Productivity Management Corporation".</li> <li>The occupational safety commission regularly formulates annual plans, conducts patrols, inspects equipment, etc., and</li> </ul>	5 8 9
	<b>Governance</b> <ul style="list-style-type: none"> <li>Active efforts to strengthen governance, including the establishment of the risk management and compliance committee comprised of executives and senior executives</li> <li>Establish an "Internal Audit Office" to promote internal</li> </ul>	12 17

**ZAP**

This comprehensive list might be easier for you to understand!

Morooka's current activities are listed into the three ESG factors, which also shows the applicable SDGs items.

ESG consists of three factors, which companies must be concerned about for their sustainable management and growth.

And SDGs are globally-common 17 items to be achieved by 2030.

They are "sustainable development goals".

Adopted at the UN Summit in 2015.

I wear the SDGs' badge.

Do I look cool?

In detail Click here [▶▶](#)



**MOROOKA Co., Ltd.**

358, Shoubeshindenmachi, Ryugasaki city, Ibaraki Prefecture, 301-0031, Japan  
 TEL : +81-297-66-2111 FAX : +81-297-66-3110 E-mail : info@morooka.co.jp

URL : www.morooka.co.jp (Japanese)  
 www.morooka.com (English)



MS0835W



MD181DX



BSA951C



# All for the Future

*'Japanese Quality and Expertise in the Industry'*



[www.maruyama.co.jp](http://www.maruyama.co.jp)





As the population is increasing, **Maruyama** has provided optimal machinery for increasing crop production efficiently in a limited spaces. Making great social contributions around the world.

We in MARUYAMA has firmly determined to work closely together with the agricultural community.

As arable land becomes increasingly limited, we at **Maruyama** have created the perfect tools for increased production of high-quality food.

We are confident that you will be genuinely satisfied with Maruyama products.

**“MARUYAMA”** produces everything to do with SPRAYERS and DUSTERS.

#### **Products Include**

- Tractor Mount Sprayers • Trailer Sprayers • Power Sprayers • Mist Dusters
- Hand Sprayers • Brush Cutters • Agricultural Drones



**ARIMITSU**

# New Model HOUSE SPRAYER



LVH-30CNH

The compressor is newly powered up and now available!!

- No heating-up of the chemical and make the spraying with cold fogger.
- Ultra fine spray particles of less than 2.5 microns makes less harmful effect.
- No suffering from Agricultural Chemicals due to the Unmanned Prevention System.

## Arimitsu Products



AUTO RUNNING  
PEST CONTROLLERS



PRESSURE WASHERS



POWER SPRAYERS



PORTABLE POWER SPRAYERS



KNAPSACK POWER SPRAYERS



**ARIMITSU INDUSTRY CO., LTD.**

Address 3-7,1-Chome Fukaekita,Higashinari-ku, Osaka 537-0001,Japan.

TEL: 81-6-6973-2030 FAX: 81-6-6976-1031



Open up a fruitful tomorrow

# SUZUTEC

CONGRATULATIONS!



High density support for Paddy Rice

## Nursery Seeder

— High Precision Sowing and Compact Design —

From a low density seeding to a high density seeding

**Adjustable with one dial !**

### Full Automatic Nursery Seeder **THK2009B**



Ability

200  
seeding boxes / hour

Seeding amount

90~400 g / box



Dry Paddy : 80g  
(sprouting paddy 100g)

Scattering soil ▶ Watering ▶ Seeding ▶ Covering soil

Watering and seeding can be recombined

### Automatic Nursery Seeder **HK509BM**



Ability

420·500  
seeding boxes / hour

Seeding amount

90~385 g / box

Scattering soil  
(covering soil dual purpose)

Watering ▶ Seeding ▶ Covering soil

Watering and seeding can be recombined

## SUZUTEC Co., Ltd.

44-3 Hiraidekogyodanchi, Utsunomiya-shi, Tochigi-ken 321-0905 Japan  
TEL: +81-28-664-1111 FAX: +81-28-662-5592

[www.suzutec.co.jp](http://www.suzutec.co.jp)

**Kett**

# Easy, quick and accurate moisture measurement.



Japanese standard

**Moisture**  
**Rice and Grain Moisture Tester**  
**Riceter fg series**



Japanese standard

**Moisture**  
**Grain Moisture Tester**  
**PM-650 series**



Japanese standard

**Quality of rice polishing**  
**Rice Whiteness Tester**  
**C-600**



**Composition**  
**NIR Rice Composition Analyzer**  
**AN-920**



under development

**Quality of rice appearance**  
**Rice Inspector**  
**RN-700**



We've been researching & developing Moisture testers since 1946.

**KETT ELECTRIC LABORATORY**

1-8-1 Minami-Magome Ota-ku Tokyo, JAPAN <https://www.kett.co.jp/>







**Auto-mobil**  
**MANURE**  
**SPREADER**

**Steering**  
**MANURE**  
**SPREADER**



**VEGETABLE**  
**TRANSPLANTER**

**DELICA CO.,LTD.**

5511-11 Wada, Matsumoto, Nagano 390-1242, Japan

<http://www.delica-kk.co.jp/en/>



# ASHORAGRO

PRODUCTS BY **Q-HOE**  
Co.,Ltd.

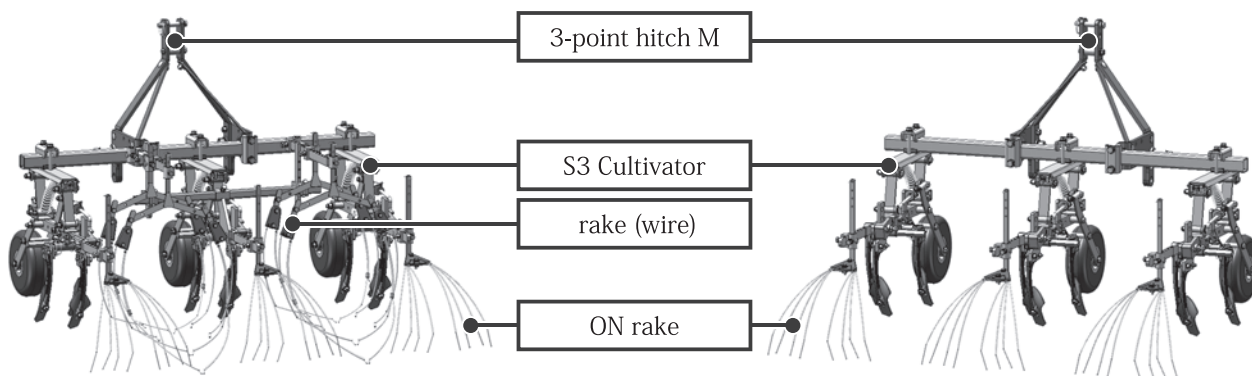

S3 Cultivator DX 3 row

S3 Cultivator 3 row

S3 cult series, which is small but full of various mounting methods and functions.

- Because it is a towed weeding machine, the work speed can be as high as 2 to 10 km (1 mph - 6 mph)
- A rake (wire) for weeding between strips is attached, and weeds are pulled out and killed.
- At the end is an ON rake (rake).
- Adaptive field force: 5 to 38ps
- Correspondence between strips : 45 to 80cm

**WEB SITE : [q-hoe.com/](http://q-hoe.com/)**

**Twitter ID : @QHOE\_Official**

# FURROW OPENER

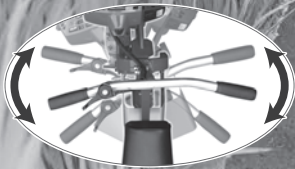

Here comes steering !

With the steering system, you can turn NORUTAN EVO while riding it !

The minimum turning radius **1.5m**

The video is here !



NTH-1

For favorable growth of paddy rice

**MINI CULTI NORUTAN EVO**

# MINI CULTI Weeding machine

exclusive attachment corresponds article 5 & 7

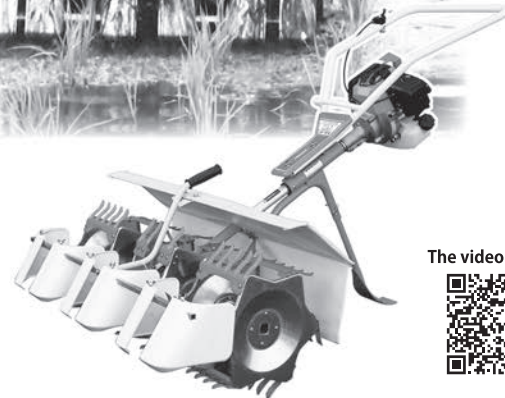

The video is here !



Initial & Essential Operation for Inter tillage / Weeding

Imperative Shaking Sorter

# Rice Husker Well Done!

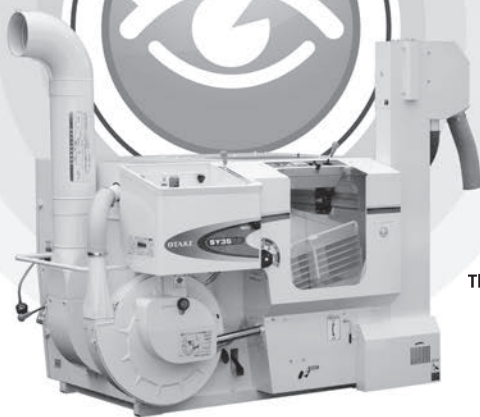

SY35RE

The video is here !



Try imperative super technique!

**Magic Eye plus+**

No need to adjust shaking plate

# Rice hulling machine

## PM500NE

DUAL-ROLE

Rice hulling and Rice polishing AVAILABLE !



Stone Remover (S303P) Installation example

hopper height 540 mm

paddy stand height 300 mm

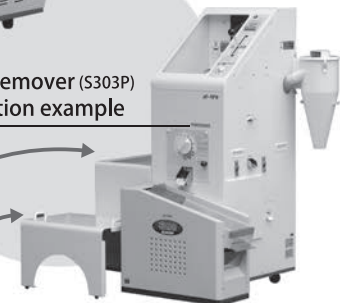

OTAKE AGRICULTURAL MACHINERY CO., LTD. [www.otake-ss.co.jp](http://www.otake-ss.co.jp)

[Head Office/Factory] 265 Gonaka, Nakajima, Oharu-cho, Amagun, Aichi-ken, 490-1145 JAPAN TEL: +81-52-444-2525 FAX: +81-52-443-0348

**Shizuoka Seiki**

# MEASURING INSTRUMENT



**Grain Analyzer**  
SGE·SRE series



**Single Kernel Moisture Meter**  
Model: CTR-500F series



**Grain Moisture Meter**  
Model: CD-6E

## BIO-MASS 60T GRAIN DRYING SYSTEM

Grain Dryer:HSD-330HS×2



**Shizuoka Seiki Co.,Ltd.**

4-1 Yamana-cho, Fukuroi-shi, Shizuoka-ken 437-8601 Japan  
Phone:+81-538-23-3990 Fax:+81-538-23-3192  
URL:<https://www.shizuoka-seiki.co.jp/english/>  
E-mail:international@shizuokaseiki.com



We specialize in Post-harvest vegetable and fruit handling Agricultural Machinery



Radish washing machine

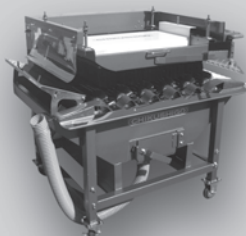

Radish washing machine



Carrot washing machine



Taro hair cutting and removing machine



Sweet potato washing machine



Sweet potato washing machine

**We have the various types of machines.**



Sweet potato washing machine



Boots washing machine



Pumpkin polishing machine



Watermelon polishing machine

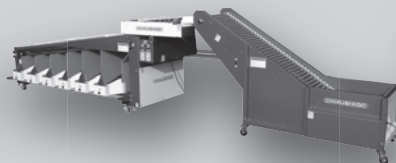

mini tomato size sorting machine



tomato weight sorting machine

**CHIKUSHIGO CORPORATION**

<http://www.chikushigo.co.jp>

29-3 ino,Umi-machi ino,Kasuya-gun,  
Fukuoka-ken,811-2104 JAPAN

TEL:+81-92-932-1662 FAX:+81-92-933-5787

# Pot system suitable for Organic rice crop

**POT448**



**<Full size>**

**Rice transplanter**

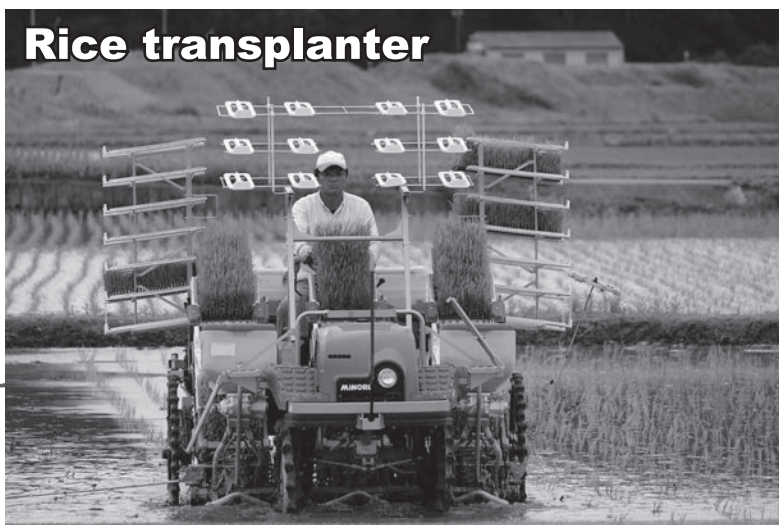

## 《POT SYSTEM》

- Designed to use special nursery tray with 448 pots
- Seeding 2-3 rice seeds per pot
- Prepared seedlings for transplanting with more than 4.5 leaves each and 15 cm height are disease resistant and easy for flooding cultivation
- 33 cm row spacing assures wide space planting
- Maximum operating speed of weeder is about 1.2 m/s.  
Inter row space is weeded by forced rotor and inter plants is weeded by forced vibrating tooth

**Weeding machine**



**MINORŪ INDUSTRIES CO., LTD.**

Head Office & Factory : 447,shimoichi,Akaiwa,Okayama,709-0892,Japan

URL <http://www.minoru-sangyo.co.jp>

Thinking ahead about tomorrow's farming.

**KAWABE**

# KAWABE is special machinery pioneer.

## Self-propelled trencher **NF-843**



An essential machine for fields,  
plastic greenhouse  
and orchards.

YouTube Movie



## Trencher with a tractor Rotary and Chain ladder type.

**RL-822**

**TT-622**

**TL-804**

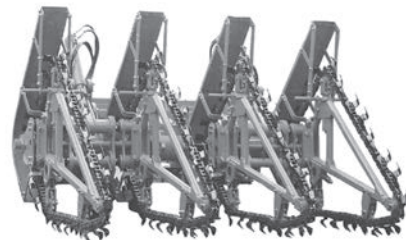
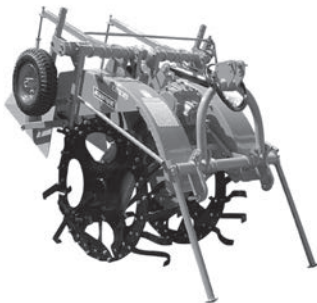

### Contact Us

More than 60 years, Pioneer for special farm supply

**Kawabe Noken Sangyo K.K**

574-4 Yanokuchi, Inagi-shi, Tokyo 206-0812 Japan

+81-42-377-5021 <http://www.kawabenoken.co.jp/en/>



### No-Tillage V-Shaped Furrow Paddy Seeder

For direct sowing of rice

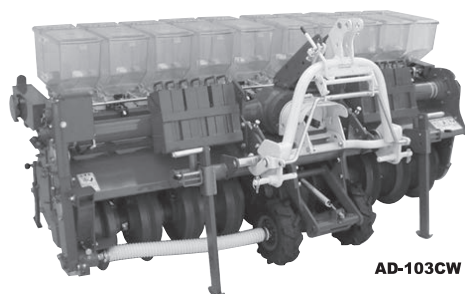

AD-103CW

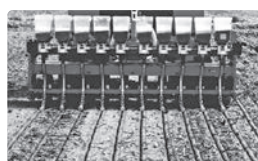

Forming V-shaped furrow for seeding and fertilization.

### ABLE Ground Cover Layer

(Semi-High Ridge)

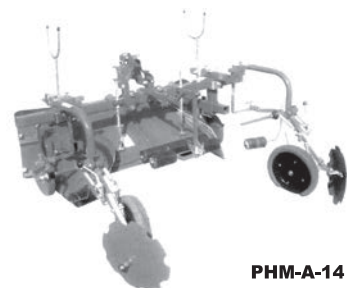

PHM-A-14

- Attached to rotary to form ridge & lay ground cover easily in both dry and rice fields.

### SUPER ABLE Ground Cover Layer

(Semi-High Ridge)

High performance

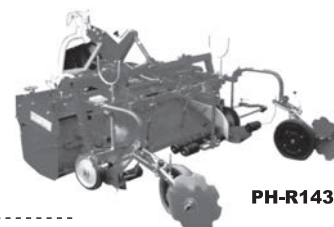

PH-R143M

- Ridger & Ground Cover Layer suitable for change of crops/second vegetable transplanting.

### SUPER Trapezoid Ridger

- Easily attached/detached, suitable for forming vegetable cropping ridge, easy operation.

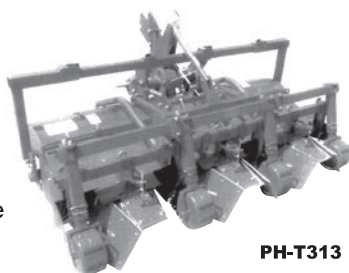

PH-T313

### SUPER Ground Cover Layer for Small Ridge

JR-913M

- Easily adjusted, simple, compact and high-performance ridger and ground cover layer.

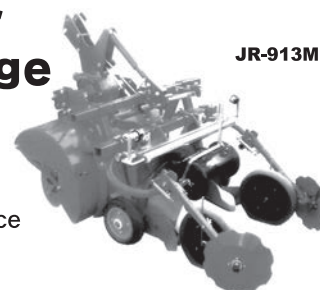

### Simple Ground Cover Layer

Easily handled

- Flat ridge easily covered utilizing automatic deep tillage of rotary.



SFM231

### ABLE Potato Planter

Reducing work load by rational operation

- Planting, ridging and ground cover laying in one operation.

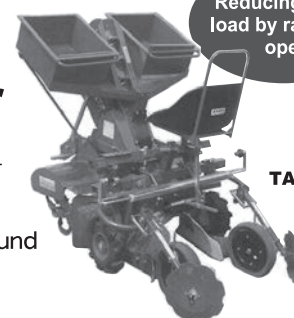

TAP-113M

**SUKIGARA AGRICULTURAL MACHINERY CO., LTD.** [www.sukigara.co.jp](http://www.sukigara.co.jp)

38 Sairinji, Yahagi-cho, Okazaki-shi Aichi-ken, 444-0943 Japan TEL. +81-564-31-2107 FAX. +81-564-33-1171



# ASABA Sprayers helping you towards an abundant harvest

## BATTERY SPRAYER (rechargeable type)

### BP-15Li-DX

Tank capacity: 15L  
Weight : 3.9kg  
Maximum Pressure: 0.4MPa  
Total flow: 72~288L  
Time of use: 60~240min



## KNAPSACK POWER SPRAYER WITH ENGINE

### EP-220D

Tank capacity: 20L  
Weight : 8.7kg  
Maximum Pressure: 2.5MPa  
Suction volume: 7.0L  
Engine: Two-stroke



## HERBICIDE APPLICATOR FOR FURROW

Tank capacity: 20L  
Weight : 16kg  
Maximum Pressure: 2.5MPa  
Suction volume: 7L/min  
Engine: Two-stroke  
width of Spray(cover): 300~800mm  
width of Spray(uncover): 1200mm

## POWER SPRAYER WITH ENGINE

### NS-283GB

Weight: 28.6kg  
Maximum pressure: 3.5Mpa  
Suction volume: 25L/min  
Engine: Four-stroke

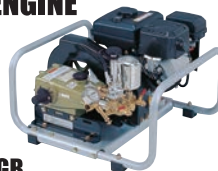

## GOLD AP-1 NOZZLE

Flow(2.0MPa) : 4.6 ~ 13.2L  
Distance : 11.0m  
Length : 120x150mm  
Weight : 450g



## SUPER JET NOZZLE Type 1

Flow(2.0MPa) : 6.4 ~ 8.8L/min  
Distance : 9.0m  
Length : 880mm / Weight : 550g



## ASABA MANUFACTURING, INC.

Head office: 1443-2 Kitanagaike, Nagano-City, Nagano, Japan  
Phone: +81-26-244-1317 Fax: +81-26-241-3207  
URL: <https://www.asaba-mfg.com/>

# Genuine Japanese Nylon Cord

## We Manufacture Unique Nylon cord

- Bamboo mix
- Shel mix
- Walnut mix etc.

## Many kinds of Nylon Cord

Made of Japanese Material,  
made by Japanese Technology  
& made in Japan



## CAL ENTERPRISE CO., LTD.

1289-1 Yamabe, Tateshina-machi, Kitasaku-gun,  
Nagano-Pref., Japan (post code 384-2307)  
TEL +81-267-2691 FAX +81-267-56-2696  
E-Mail: [info@calenter.co.jp](mailto:info@calenter.co.jp) URL: <http://www.calenter.co.jp>





We provide a series of machines from nursery cabinet to conveyor and try to help farmers for more efficient farm work.

### container

- For conveying rough rice from field
- Fit for compact tractors
- With optional caster and rough rice conveyance hose, you can easily set it up and take out rough rice in a short time



capacity (GK11-BG)  
1500 - 4900 L

### nursery cabinet

- For favorable growing of seedlings
- Keeping a fixed temperature in the range of 5°C to 40°C
- Easily assembled and installed



(NK-240)

## Ishii Factory Co., Ltd.

4-1-13 Kyoden, Sakata-shi, Yamagata-ken 998-0102, JAPAN  
TEL: +81-234-28-8239 FAX: +81-234-28-8256  
URL: <https://isi-mfg.com/> E-mail: [isi-support@isi-mfg.com](mailto:isi-support@isi-mfg.com)



Food washing machine **TIGER Kawashima**



**AQUA WASH Master / TWS-1300AB**

The foodstuffs are washed gently and securely with the power of **[water stream] + [foam]**

**96%** foreign substances removal rate

\* Result of a test conducted by our company.

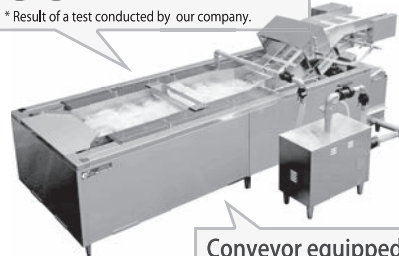

Conveyor equipped For mass processing

Specifications

Estimated throughput	200~800 kg/h	Electric capacity	Three-phase 200V 2.7kW
----------------------	--------------	-------------------	------------------------



Lettuce



Tomato



Broccoli



Pineapple

etc...

## TIGER KAWASHIMA Co., Ltd.

2876 Momiya, Itakura-machi, Oura-gun, Gunma, 374-0134, JAPAN  
URL: <https://www.tiger-k.co.jp/global/> TEL: +81-276-55-3001



## New generation of weeds mower

Would you spend your time for mowing forever?



Location: Orchard, Japan

The Robotic Mower "MR-300"

# KRONOS

## -for Weeds-



**-3WD-**  
Available in bumpy fields



**-Automatically-**  
Mowing and Charging



**-Motor Drive-**  
Silent but Powerful

Mowing Height: 30~70mm Mowing Capacity: 3,000m<sup>2</sup> Mowing/Charging: 1 hr/1hr L×W×H : 845×520×360mm

※A smartphone (tablet) is required to operate this product. ※A field survey and installation work by a technician is required for use.

## WADO Co., Ltd.

<https://www.wadosng.jp/>  
Email: [wado@wadosng.jp](mailto:wado@wadosng.jp)

**YouTube**

Click here for the video ▶



*International specialized medium for agricultural mechanization in developing countries*

ISSN 0084-5841

# AMA

**AGRICULTURAL MECHANIZATION IN ASIA, AFRICA AND LATIN AMERICA**

VOL.51, No.4, SUMMER 2020

---

*Edited by*

YOSHISUKE KISHIDA

*Published quarterly by*

Farm Machinery Industrial Research Corp.

*in cooperation with*

The Shin-Norinsha Co., Ltd.

and

The International Farm Mechanization Research Service

TOKYO

**AFRICA**

Kayombo, Benedict (Botswana)  
Fonteh, Fru Mathias (Cameroon)  
Ndindeng, Sali Atanga (Cote d'Ivoire)  
Abdallah, Said Elshahat (Egypt)  
El Behery, A. A. K. (Egypt)  
Addo, Ahmad (Ghana)  
Bani, Richard Jinks (Ghana)  
Djokoto, Israel Kofi (Ghana)  
Some, D. Kimutaiarap (Kenya)  
Gitau, Ayub N. (Kenya)  
Houmy, Karim (Morocco)  
Alonge, Akindele Folarin (Nigeria)  
Oyelade, O. A. (Nigeria)  
Bindir, Umar B. (Nigeria)  
Igbeka, Joseph C. (Nigeria)  
Odigboh, E. U. (Nigeria)  
Oni, Kayode C. (Nigeria)  
Opara, U. L. (South Africa)  
Kuyembah, N. G. (Sierra Leone)  
Abdoun, Abdien Hassan (Sudan)  
Saeed, Amir Bakheit (Sudan)  
Khatibu, Abdisalam I. (Tanzania)  
Tembo, Solomon (Zimbabwe)

**AMERICAS**

Cetrangolo, Hugo Alfredo (Argentina)  
Nääs, Irenilza de Alencar (Brazil)  
Ghaly, Abdelkader E. (Canada)  
Hetz, Edmundo J. (Chile)  
Roudergue, Marco Antonio Lopez (Chile)  
Aguirre, Roberto (Colombia)  
Ulloa-Torres, Omar (Costa Rica)  
Mesa, Yanoy Morejón (Cuba)  
Rondon, Pedro Paneque (Cuba)  
Luna-Maldonado, A. I. (Mexico)  
Magaña, S. G. Campos (Mexico)  
Ortiz-Laurel, H. (Mexico)  
Bora, C. Ganesh (U.S.A.)  
Goyal, Megh Raj (U.S.A.)  
Mahapatra, Ajit K. (U.S.A.)

**ASIA and OCEANIA**

Farouk, Shah M. (Bangladesh)  
Hussain, Daulat (Bangladesh)  
Mazed, M. A. (Bangladesh)  
Ali, Rostom (Bangladesh)  
Wangchen, Chetem (Bhutan)  
Basunia, M. A. (Brunei)  
Li, M. (China)  
Luo, X. (China)  
Ilyas, S. M. (India)

Mani Indra (India)  
Mehta, C. R. (India)  
Michael, A. M. (India)  
Nath, Surya (India)  
Pathak, B. S. (India)  
Salokhe, Vilas M. (India)  
Singh, Gajendra (India)  
Verma, S. R. (India)  
Soni, Peeyush (India)  
Abdullah, Kamaruddin (Indonesia)  
Behroozi-Lar, Mansoor (Iran)  
Minaei, Saeid (Iran)  
Mahdavian, Alireza (Iran)  
Abdul-Munaim, Ali Mazin (Iraq)  
Hasegawa, Hideo (Japan)  
Snohar, Bassam A. (Jordan)  
Chung, Jong Hoon (Korea)  
Lee, In-Bok (Korea)  
Bardaie, Muhamad Zohadie (Malaysia)  
Gonchigdorj, Enkhbayar (Mongolia)  
Pariyar, Madan P. (Nepal)  
Jayasuriya, Hemanatha P. W. (Oman)  
Khan, Alamgir A. (Pakistan)  
Mughal, A. Q. A. (Pakistan)  
Mirjat, Muhammad Saffar (Pakistan)  
Abu-Khalaf, Nawaf A. (Palestine)  
Lantin, Reynaldo M. (Philippines)  
Venturina, Ricardo P. (Philippines)  
Al-suhaibani, Saleh Abdulrahman (Saudi Arabia)  
Al-Amri, Ali Mufarreh Saleh (Saudi Arabia)  
Illangantileke, S. G. (Sri Lanka)  
Chen, Suming (Taiwan)  
Krishnasreni, Suraweth (Thailand)  
Phongsupasamit, Surin (Thailand)  
Senanarong, Akkapol (Thailand)  
Ertekin, Can (Turkey)  
Haffar, Imad (United Arab Emirates)  
Hay, Nguyen (Viet Nam)  
Lang, Pham Van (Viet Nam)

**EUROPE**

Katardjiev, Tihomir Hristov (Bulgaria)  
Kic, Pavel (Czech)  
Müller, Joachim (Germany)  
Ferentinos, Konstantinos P. (Greece)  
Sigrimis, Nick (Greece)  
Gasparertto, Ettore (Italy)  
Lobachevsky, Y. (Russia)  
Martinov, Milan (Serbia)  
Jaime, Ortiz-Cañavate (Spain)  
Sims, Brian G. (U.K.)

**EDITORIAL STAFF**

(Tel.+81-(0)3-3291-3674)

Yoshisuke Kishida, Chief Editor  
Shinjiro Tetsuka, Managing Editor  
R. Lal Kushwaha, Editorial Consultant

**ADVERTISING**

(Tel.+81-(0)3-3291-3674)

Yuki Komori, Director (Head Office)  
Advertising Rate: 300 thousand yen per page

**CIRCULATION**

(Tel.+81-(0)3-3291-3674)

(Fax.+81-(0)3-3291-5717)

Editorial, Advertising and Circulation Headquarters  
1-12-3, Kanda Nishikicho, Chiyoda-ku, Tokyo 101-0054, Japan  
URL: <https://www.agriculturalmechanization.com/>  
E-Mail: [ama@shin-norin.co.jp](mailto:ama@shin-norin.co.jp)

Copyright © 2020 by  
FARM MACHINERY INDUSTRIAL RESEARCH CORP.  
in SHIN-NORINSHA Co., Ltd

Printed in Japan

## EDITORIAL

AMA is finally celebrating its 50<sup>th</sup> anniversary. When I was 28 years old, 80% of the world population were farmers in developing countries and the economic gap between farmers and the city people was so huge. If the economic gap widens on the narrowing planet, stress will increase and it will be difficult to realize a peaceful world. We thought of ways to better communication with experts in developed countries and experts in developing countries by working together to promote appropriate agricultural mechanization for farmers in developing countries. AMA which connects those experts around the world for agricultural mechanization and was born in this way.

The first issue was published in spring of 1971. The first title was Agricultural Mechanization in South-east Asia. I printed 10,000 copies and distributed them around the world, I received many letters, especially from the Asian region. They said that we have the same problem and the contents, they wanted me to make this journal including the whole area of Asia. Therefore, I published AMA in the next year with the new title of 'Agricultural Mechanization in Asia' (AMA).

Ten years later, in 1981, a professor who was a cooperating-editor, Dr. Moens of Univ. of Wageningen asked me to change the title from AMA to AMW because AMA is widely read by experts in Africa, Latin America as well as Asian countries. He claimed that the title Asia was strange. However, since the title of the AMA is familiar for ten years to everyone, I didn't want to change this title 'AMA' and I decided 'A', meant 3 continents as for African continent, Asian continent, Latin American continent.

It has past been 50 years, and when I started AMA in 1971, I couldn't have expected that the AMA journal would last for 50 years. But with the great help of experts from all over the world, especially with the great help from cooperating editors, AMA grew up brilliantly. AMA could get 'Impact Factor' of Thomson Reuters 8 years ago. I think AMA was evaluated internationally as excellent journal. There are many cooperating editors who already passed away. In total, 153 experts have cooperated for AMA in 50 years. I deeply appreciate for their kind and valuable cooperation for AMA.

Agricultural Mechanization in the world is trying to renew that aspect. Advances in AI and computers will bring agricultural machinery new wise brain. There were demands for appropriate technology for farmers in developing countries, but what exactly is appropriate technology in new age of mechanization? It changes with the times. In the near future, farmers in developing countries will probably use simple agricultural machine robots. Let's promote new agricultural mechanization for the world's agricultural production in a new era under changing climate condition. I'll deeply appreciate for your cooperation for AMA in the future.

**Yoshisuke Kishida**  
**Chief Editor**  
November, 2020

# CONTENTS

## AGRICULTURAL MECHANIZATION IN ASIA, AFRICA AND LATIN AMERICA

Vol.51, No.4, Autumn 2020

### AMA 50<sup>th</sup> Anniversary Special Edition: SDGs and Agricultural Mechanization

Yoshisuke Kishida	29	Editorial
Masatoshi Kimata	31	SDGs of Agricultural Machinery Industry in Japan
Ken Kobayashi	36	Smart Agriculture Research in IAM-NARO
Yasushi Hashimoto	38	As a Successful Contribution for New Agriculture Paradigm
Naoshi Kondo	40	Smart Agriculture for 9 Billion People's Food Production and Environmental Conservation Aiming SDGs
Noboru Noguchi	42	Smart Robots for Production Agriculture for SDGs
Sakae Shibusawa	48	Digital Farming Strategy toward Agricultural Transformation
Teruaki Nansaki	53	Mechanization, Digitizing and Innovations in Agriculture
Kenji Omasa	55	Need for Mechanization of Agriculture with Environmental Protection in Developing Countries
Hideo Hasegawa	56	Overseas Expansion of Japanese Agricultural Machinery through Cooperation with International Cooperation Agency
Yuichi Kitao	58	SDGs and Kubota's Vision
John K. Schueller	60	Agricultural Mechanization in the United States of America
Brian Sims, Josef Kienzle	64	Fifty Years of Progress in Agricultural Mechanization
Karl Th. Renius	67	50 Years of AMA, the SDGs and Agriculture in Germany
Peter Pickel	70	Development Trend "Digital Agriculture" from a German Perspective
Peter Schulze Lammers	74	Mechanization of Agriculture in Germany
P. Kic	77	The Role of Life Sciences Universities in Relation and Strategy of Sustainable Development Goals
M. Martinov, Dj. Djatkov, S. Bojic, M. Viskovic	82	Serbian Agriculture, Agricultural Engineering – Past and Future
Chen Zhi	84	Sustainable Development of Chinese Agriculture and Food Security
Yang Minli, Li Minzan, Luo Xiwen	86	50 Years of Agricultural Mechanization in China
Zhao Yanshui	93	Current Status and Prospects of Agricultural Mechanization in China
Indra Mani	96	SDGs and Agricultural Mechanization in India
C. R. Mehta, N. S. Chandel, Y. A. Rajwade	99	Smart Farm Mechanization for Sustainable Indian Agriculture
A. Rahman, Md. R. Ali, Md. S. N. Kabir	106	Agricultural Mechanization in Bangladesh: Status and Challenges towards Achieving the Sustainable Development Goals (SDGs)
Md. M. Rahman, Md. R. A. Mamun, Md. A. Hossen	121	The Regional Network for Agricultural Machinery
Reynaldo M. Lantin	133	Agricultural Mechanization Today in Indonesia in Relation to the SDGs
Kamaruddin Abdullah	135	Sustainable Development for Agricultural Products Processing Industry and Agricultural Mechanization in Vietnam
Nguyen Hay	137	Egyptian Agriculture and Current Situation of Agricultural: Tractors and Equipment in Egypt 2009-2018
Taher Kadah, Rania Khamis Ibrahim Hanafi Radwan, Ahmed El Behery	146	SDGs and Storage Obstacles of Agricultural Production in Egypt
Said Elshahat Abdallah, Wael Mohamed Elmessery	151	SDGs and Agricultural Mechanization Practice in Nigeria
Oyelade, Opeyemi Adeniyi	155	Agricultural Mechanization Today in Nigeria in Relation to Sustainable Development Goals
Akindele Folarin Alonge	157	Draft Efforts' Behavior of a Vibratory Tool to Different Forward Speeds
L. O. M. Cabrera, A. M. Rodriguez A. G. de la Figal Costales, Y. M. Mesa		



CONGRATULATORY MESSAGE for AMA 50<sup>th</sup> Anniversary.....163

New Co-operating Editors .....	35
Event calender .....	47
Co-operating Editors.....	176

Subscription Information .....	182
Advertisers' Index .....	183

# SDGs of Agricultural Machinery Industry in Japan



by  
**Masatoshi Kimata**  
 President of Japan Agricultural Machinery  
 Manufacturers Association  
 (Chairman and Representative Director of KUBOTA  
 Corporation)  
 JAPAN

## Introduction

First of all, I sincerely congratulate AMA on its 50th anniversary. I would like to pay tribute to Mr. Yoshisuke Kishida's great contribution, through which AMA, as an international magazine on agricultural mechanization, has continuously been published for 50 years.

"SDGs and agricultural mechanization of the world" is a very timely issue.

Agricultural machinery manufacturers are keenly aware of the importance of SDGs and making efforts to associate their activities with the SDGs in accordance with their respective situations.

Regarding SDGs in agriculture and agricultural machinery sector, I will give an overview of the government's efforts at first, and then the private sector's efforts including KUBOTA Initiatives hoping that useful information is conveyed to readers.

## Government Policy

In December 2019, the Japanese government revised "SDGs Implementation Guiding Principles", which is a mid-to-long term national strategy for implementing the 2030 Agenda and achieving the SDGs in Japan and internationally by 2030. The principle set the following eight priority areas for efforts toward the

establishment of Japan's "SDGs Model" (Table 1).

Specific measures and their budgets to promote each priority areas are visualized in the SDGs Action Plan formulated by the Promotion Headquarters. The latest version, which is "SDGs Action Plan 2020", illustrates three main pillars, i.e., "Business and Innovation," "Regional Revitalization," and "Empowerment of the Next Generations and Women", in order to accelerate the establishment of Japan's "SDGs Model".

Smart agriculture, which is deeply relevant to the agricultural machinery industry, is included in the first pillar, "Business and Innovation". Stable food supply, sustainable agriculture and rural development are not implicitly shown in the pillars, but described as important components in the related priority areas.

The agricultural machinery industry fully supports such government policies on SDGs. I am convinced that experience and knowledge accumulated in the industry will continue to contribute to achieving the SDGs in Japan, as well as in the world, through solving various issues in the agricultural sector.

## Initiatives by Private Sectors

### Charter of Corporate Behavior by Keidanren

Keidanren (Japan Business Federation) revised its Charter of Corporate Behavior in 2017 (the original version was published in 1991), in which the principles of the responsible behavior by corporations are laid down, with the primary aim of proactively delivering on the SDGs

**Table 1** Eight priority areas in the "SDGs Implementation Guiding Principles"

(People)	1 Realization of gender equality and a society where every person can play an active role
	2 Achievement of good health and longevity
(Prosperity)	3 Creating growth markets, revitalization of rural areas, and promoting science & technology and innovation
	4 Sustainable and resilient land use, promoting quality infrastructure
(Planet)	5 Energy conservation and renewable energy, disaster risk reduction and climate change countermeasures, sound material-cycle society
	6 Conservation of biodiversity, forests, and oceans, and other environments
(Peace)	7 Achieving peaceful, safe and secure societies
(Partnership)	8 Strengthening the means and frameworks for the implementation of the SDGs

through the realization of “Society 5.0” in 2017.

“Society 5.0”, which was advocated by the Cabinet Office in 2016, means the fifth and newest society in the history of human social development, following on from the hunter-gatherer society, agrarian society, industrial society, and information society. The creation of such a society is in line with the SDGs, as shown in the subtitle of the Charter. “For the Realization of a Sustainable Society”: Member corporations are expected to fulfill their social responsibility with a strong sense of ethical values, by acting according to the following ten principles (Table 2).

The Charter explicitly requires member corporations to act towards the achievement of the SDGs. The

**Table 2** Ten principles in the “Charter of Corporate Behavior”

- Sustainable economic growth and the resolution of social issues
- Fair business practices
- Fair disclosure of information and constructive dialogue with stakeholders
- Respect for human rights
- Relationships of trust with consumers and customers
- Reform of work practices and enhancement of workplace environments
- Engagement in environmental issues
- Involvement in community and contribution to its development
- Thorough crisis management
- Role of top management and implementation of this Charter

role of a corporation is to realize a sustainable society on the basis of fair and free competition. Members of the agricultural machinery industry will fulfill their social responsibility in cooperation with members of the other industries.

**JAMMA Activities**

Japan Agricultural Machinery Manufacturers Association (JAM-

MA) is the nationwide organization of agricultural machinery manufacturers in Japan, founded with the aim of contributing to the sound development and progress of agricultural machinery industry as well as the growth of national economy.

The scope of JAMMA’s works extends to a wide range of issues, such as the development of safety technology, matters on the environment

**Table 3** Social issues to be addressed by Kubota Group

Areas	Situations	Expectations
Food	- The world production of major crops in FY2027 is expected to increase by 12.2% compared to FY2017	Based on the projection of the farm population and the crop harvest area, the crop yield growth is needed for the increase of the production. The mechanization of agriculture, including the installation of smart agriculture will be essential for enhancing the productivity.
	- The world harvest area of major crops in 2027 will be expected to be almost the same level as the average of those in 2014-2016 (700 million ha)	
	- The world population in 2027 is estimated to increase by 10.4% compared to 2017	
	- The net increase in the world population from 2017 to 2027 will occur in the urban population, and not in the rural population	
Water	In developing countries, as of 2015, - 2.1 billion people lack access to “safely managed” water - 840 million people have still not received the basic water supply - 4.5 billion people have no access to “safely managed” sanitary facilities	Development of safe water, sewage and sanitary facilities is expected.
	In Japan, the deterioration of water/sewerage pipelines and facilities, and securing enough manpower and handing down expertise and skills in the aging society are the big issues.	Efficient operation of water supply and sewerage undertakings are expected.
Environment	- The ratio of the urban population to the total world population is estimated to rise from 55% in 2017 to 60% in 2030. - The number of cities with a population of 10 million or more (megacities) will increase from 33 in 2018 to 43 in 2030.	In accordance with the progress of urbanization, further development of social infrastructure is expected.
	- The frequencies of rainstorms, flooding’s, water shortages, etc., which is said to be related to the global warming seem to increase. The risks of natural disasters, such as typhoons, earthquakes and tsunamis, etc., also seem to increase.	The disaster prevention and preparation as well as the prompt restoration measures after disasters are expected.



regulation, standardizations related to agricultural machinery, export promotion, etc.

Agricultural machinery is indispensable for farmers, and contributes to increase the productivity of food production which is related to the Goal of the SDGs. In addition, I recognize that standardization, exhaust gas regulation compliance and smart agriculture are also positioned in the SDGs. JAMMA will continue to actively promote these activities.



**KUBOTA Initiatives**

The Kubota Group is committed

to achieving SDGs in the areas of food, water, and the environment, which are indispensable for human beings. The Kubota Group continues to support the future of the earth and human society through providing its products, technologies and services (Fig. 1, Table 3, Table 4).

**Kubota Aims for Smart Agriculture**

By promptly introducing ICT (information and communication technology) and robotic technology in agriculture, Kubota will realize smart agriculture that reduces labor and increases precision, contributing to the abundant and stable production of food.

**Fig. 1 KUBOTA Global Loop**

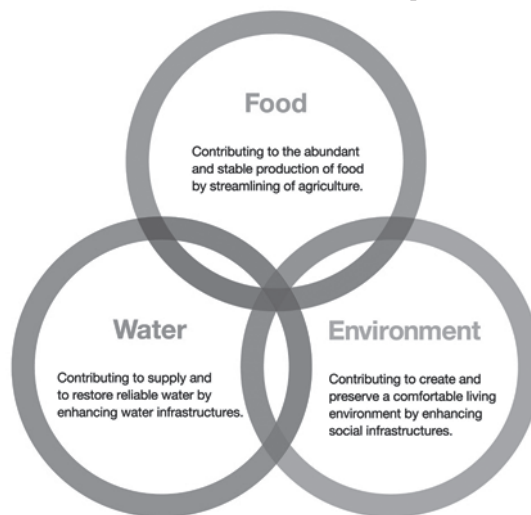

**Kubota Smart Agri System (KSAS)**

KSAS is a farm management information system, consisting of two parts, i.e., “Farming support system” and “Machinery service system”. “Farming support system

**Table 4 Contributions to SDGs by KUBOTA GROUP**

Areas	Approach to creating value (Approach to promoting SDGs)	Main related SDGs	The Kubota Group’s SDGs KPI
Food	Contribute to the abundant and stable production of food by the streamlining of agriculture.	2 ZERO HUNGER	- Contribution to the food production through further spreading agricultural machineries
		1 NO POVERTY	- Promotion of smart agriculture utilizing IoT and robot technologies (KUBOTA Smart Agri System (KSAS))
Water	Contribute to the supply and restoration of reliable water by enhancing water infrastructures.	6 CLEAN WATER AND SANITATION	- Contribution to the development of sustainable water-related infrastructure, through providing products, technologies and services, related to water and sewage, as well as water treatment facilities
		3 GOOD HEALTH AND WELL-BEING	- Contribution to the efficient operation of water-related facilities, through utilizing IoT technologies, as well as combining expertise on the water-related products and the expertise on water treatment technology, mapping/design technology and construction.
Environment	Contribute to creating and preserving a comfortable living environment by enhancing social infrastructures.	11 SUSTAINABLE CITIES AND COMMUNITIES	- Contribution to the development of environment friendly and sustainable urban infrastructures
		7 AFFORDABLE AND CLEAN ENERGY	- Contribution to the development of sustainable and resilient urban infrastructures that are robust against disasters

collects and stores a variety of agricultural data through automated agricultural machinery with IoT device and field/remote sensing system etc. Based on the analysis of the collected data, farmers can improve farming practices and increase profitability. With “Machinery service system”, farmers can receive a timely maintenance service. KSAS enables efficient farm operations, relying not on experience and intuition, but on data (Fig. 2).

### Kubota Agricultural Machinery with GPS

Using GPS (global positioning system), Kubota has developed an autonomous tractor and rice transplanter capable of performing unmanned automatic operations under manned monitoring, as well as combine harvester that carries a human operator while performing autonomous operations, and a rice transplanter able to self-steer to keep a straight line of travel (Fig. 3).

### Final Comments

The private sector is being called on to exercise creativity and innovation to deliver on the Sustainable Development Goals (SDGs) for realizing a sustainable society.

Understanding that the development of the private sector is founded on the realization of a sustainable society, and the private sector should fulfill its social responsibility.

Fig. 2 Kubota Smart Agri System (KSAS)

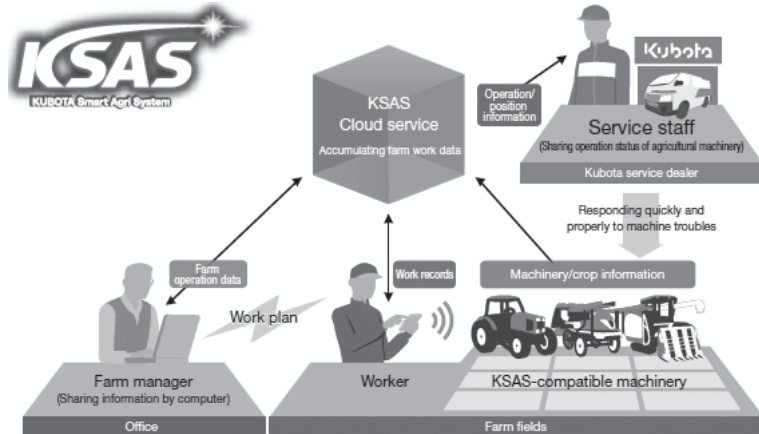

According to “World Population Prospects in 2019” published by the United Nations, the global population is projected to grow to around 8.5 billion in 2030, 9.7 billion in 2050, and 10.9 billion in 2100, from 7.7 billion in 2019 (Fig. 4).

FAO estimates that “to meet demand, agriculture in 2050 will need

to produce almost 50 percent more food, feed and biofuel than it did in 2012” (Table 5).

Under the constraint of farm lands, the increase in production would be achieved mainly through yield growth.

I believe that agricultural machinery industry must play a key role

Fig. 4 Population size and annual growth rate for the world

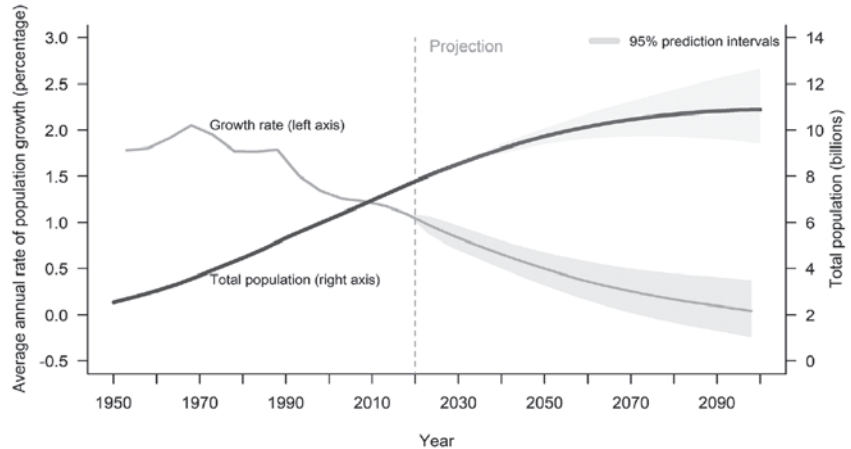

Estimates, 1950-2020, and medium-variant projection with 95% prediction intervals, 2020-2100

Fig. 3 Kubota Agricultural Machinery with GPS



AGRIROBO Tractor capable of performing unmanned automatic operations



AGRIROBO Combine harvester with automated driving assist function



Rice transplanter with keeping straight function

**Table 5** Increase in agricultural production required to match projected demand, 2005-2050 (%)

	2005/07	2050	2005/07 2012	2013-2050
World				
As projected in AT2050	100	159.6	14.8	44.8

Source: FAO 2017, "The future of food and agriculture"

in the improvement of agricultural productivity. We should continue to move forward, recognizing that expectations to the industry are growing, and at the same time our responsibility becomes greater.

Last but not least, I would like to express my deepest appreciation to AMA for giving me this kind of opportunity. I wish AMA will continue to flourish as an international magazine of agricultural mechanization in the future.

## REFERENCES

**Prime minister's office of Japan**  
SDGs Implementation Guiding Prin-

ciples Revised Edition:  
[https://www.kantei.go.jp/jp/singi/sdgs/pdf/jisshi\\_shishin\\_r011220e.pdf](https://www.kantei.go.jp/jp/singi/sdgs/pdf/jisshi_shishin_r011220e.pdf)

SDGs action plan 2020:  
<https://www.kantei.go.jp/jp/singi/sdgs/dai8/actionplan2020.pdf>

**Keidanren (Japan Business Federation)**

Charter of Corporate Behavior:  
<https://www.keidanren.or.jp/en/policy/csr/charter2017.pdf>

**KUBOTA Corporation**

The Kubota Group Mission, KUBOTA REPORT 2019:

[https://www.kubota.com/report/pdf/report2019\\_04.pdf](https://www.kubota.com/report/pdf/report2019_04.pdf)

KUBOTA Group's social issues and contribution to SDGs, KUBOTA

REPORT 2019:

[https://www.kubota.co.jp/report/pdf/report2019\\_09.pdf](https://www.kubota.co.jp/report/pdf/report2019_09.pdf)

Major Products of the Kubota Group:  
[https://www.kubota.com/report/pdf/report2019\\_10.pdf](https://www.kubota.com/report/pdf/report2019_10.pdf)

**United Nations**

World Population Prospects 2019 Highlights:  
[https://population.un.org/wpp/Publications/Files/WPP2019\\_Highlights.pdf](https://population.un.org/wpp/Publications/Files/WPP2019_Highlights.pdf)

**FAO**

The future of food and agriculture:  
<http://www.fao.org/3/a-i6583e.pdf>, P46

■ ■

## New Co-operating Editors



**Akindele Folarin Alonge, Ph.D, R. Eng, MNIM**

**Professor of Agricultural and Food Engineering/Consultant**

**Secretary, Technical Board**, International Commission of Agric. & Biological Engineers (CIGR) Section VI

**Vice President**, Netherlands Alumni Association of Nigeria (NAAN), Aeres University/PTC+ Chapter

**Member**, Global Engagement Committee of the American Society of Agric & Biological Engineers (ASABE)

**Past President**, African Network Group of the American Society of Agric & Biological Engineers (ASABE)

**National Executive Committee Member**, Nigerian Institution of Agricultural Engineers (NIAE)

**Visiting Professor** McGill University, Bioresource Engineering Dept., Montreal, Canada (2016)

**Address:** Dept of Agricultural & Food Engineering, Faculty of Engineering,

University of Uyo, P. M. B 1017, Uyo, Akwa-Ibom State, Nigeria 52003. Phone:+2348033603462

### WEBLINKS

**Google Scholar Profile:** <https://scholar.google.co.za/citations?hl=en&pli=1&user=wXc-FPQAAAAJ>

**Research Gate:** [https://www.researchgate.net/profile/Akindele\\_Folarin\\_Alonge/](https://www.researchgate.net/profile/Akindele_Folarin_Alonge/)

**LinkedIn:** <https://linkedin.com/in/folarinalonge/>

**Academia. Edu:** <https://uniportal.academia.edu/AkindeleFolarinALONGE/>

**ORCID:** <https://orcid.org/0000-0003-4734-3089>

**Alternate Email Address:** falonge6@gmail.com

# Smart Agriculture Research in IAM-NARO



by  
Ken Kobayashi  
Director - General,  
Institute of Agricultural Machinery (IAM) -  
National Agricultural Research Organization (NARO)  
JAPAN

## Introduction

On behalf of IAM-NARO, I would like to extend my heartfelt congratulations to the AMA on its 50th anniversary.

This magazine was launched in 1971 with the aim of introducing basic research conducted by experts from all over the world on agricultural mechanization in countries of Southeast Asia, in response to their requests during the early stage of agricultural mechanization. Since then, it has expanded its coverage to include all of Asia, Africa, and Latin America and has provided useful information to promote agricultural mechanization in these regions.

Meanwhile, the recent global spread of COVID-19 has had a major impact on food supply. In some cases, it was difficult to secure stable supply due to export restrictions on agricultural products and stagnation of logistics; thus, the need for research and investment to improve agricultural productivity has been reconfirmed.

IAM-NARO aims to contribute to the promotion of sustainable agriculture in harmony with the environment through smart agricultural machinery research and its social implementation. In this article, an overview of IAM-NARO and an outline of the smart agriculture research that has been going on currently is described.

## History of IAM-NARO

The IAM-NARO was established in 1962 with government and private company funding as the Institute of Agricultural Machinery (IAM), with the aim to promote Japanese agricultural mechanization; it was integrated with NARO in 2003. Since its establishment, the organization has contributed to the development of Japanese agriculture by conducting research and development of agricultural machinery as well as inspection testing related to performance and safety.

At the time of its establishment, the IAM-NARO has focused on research and development of paddy rice production machinery, developed the prototype of head feeding combine harvester and put a high-performance rice transplanter and a screw type axial flow combine harvester, which can be applied to rice of Japonica varieties and others, into practical use. It has contributed to labor saving and the reduction of working hours of rice cultivation; in fact, as a result of the great progress in mechanization, the working hours decreased significantly from 1,170 hours per ha in 1970 to 240 hours in 2016.

Since the 1990s, the IAM-NARO has also been working on practical applications of research for machines such as horticulture and livestock farming, which are small in market size and difficult for pri-

vate companies to develop independently. Through joint research with private companies, 77 models, more than 65% of the models developed, such as roll balers for chopped materials, cabbage harvesters, and far-infrared grain dryers, have been commercialized.

The IAM-NARO has also been involved in farm work automation research since the 1970s and have developed a gantry-type unmanned operation system for paddy fields, cable-guided tractors and speed sprayers, and the world's first robot tractor. In the fields of horticulture and livestock farming, the organization has also developed and put into practical use grafting robots, strawberry harvesting robots, and automatic systems for carrying milking units.

In testing activities, through type inspections, safety appraisals, etc., significant contributions has been made in improving the quality and safety of agricultural machinery in Japan, environmental conservation, and more. In Japan, robotic tractors were introduced to the market in 2018. The IAM-NARO has also established testing methods and evaluation standards for these robotized and automated agricultural machinery and also conducting evaluations.

Furthermore, the IAM-NARO has actively responded to international cooperation, such as the long-term dispatch of staff to Asia, Africa, and Central America and the acceptance

of trainees from overseas.

## Efforts Toward Smart Agricultural System Development and Practical Application/Spreading

Japan's calorie-based food self-sufficiency rate is 38%, which is the lowest level among major developed countries. On the other hand, in agricultural production sites, the number of large-scale farming entities exceeding 100 ha is increasing because of the decrease in the number of farmers and the aging of the population; moreover, the accumulation of farmland into the hands of the main farmers is progressing rapidly. In addition, the yield and quality of agricultural products have been declining due to high temperatures and frequent, heavy rains. For this reason, it is becoming increasingly important to develop technologies and machines that not only improve agricultural productivity while considering the environment but that can also be used easily and safely by the elderly, new farmers, and non-skilled employees as well as stably producing high-quality crops.

In response to this situation, by utilizing robot technology such as artificial intelligence (AI) and information communication technology (ICT) to make agricultural machinery such as tractors into robots, and utilizing multi-field farm management systems, weather information, and other sensing information, various public and private sectors are working on technological developments to build a smart agricultural system that enables efficient and highly accurate work.

At our institute, we have developed a robot tractor, a robot rice transplanter, a map-based variable fertilizer applicator, a yield monitoring combine harvester, and more and have already put some of them into practical use. At present, the IAM-NARO is engaged in the development and research of a multiple

robotic agricultural machinery operation system using remote monitoring, a robotic tractor that can move between fields, a weeding robot, a pig pen cleaning robot, an agricultural management system that directs robotic agricultural machinery to work plans suitable for automated work, an insect forecasting system based on meteorological data, and an automatic cow body information determination system using AI.

Furthermore, NARO is working on the "Smart Agricultural Technology Demonstration Project" with the aim of introducing developed technologies into model farms and conducting systematic technical demonstrations. This project, which started in 2019, aims to establish an optimum technology system and realize smart agriculture at an early stage by identifying and improving problems related to performance, operability, cost, etc. as well as by analyzing data related to farm work and management at 124 demonstration sites nationwide.

## Conclusion

The main target of the smart agricultural research currently being conducted is large-scale agriculture related to paddy fields on level ground; in the next step, however, we will apply it to vegetables and fruit trees that are difficult to mechanize. Dealing with hilly and mountainous areas, where the population is declining and aging more than the ground level and where there are many small and irregular fields, is also an important issue. The Institute believes that these challenges will also contribute to the establishment of smart agricultural systems in Asia.

In addition, as robotics and the automation of agricultural machinery have remarkably progressed, the Institute intends to contribute to the development of Japanese as well as worldwide agriculture by contribut-

ing to the provision of high-quality agricultural machinery through R&D and testing and evaluation, while maintaining consistency with the international standardization of ISOs and OECD Tractor Test Codes, or by making proposals from the Japanese side.

■ ■

# As a Successful Contribution for New Agriculture Paradigm

by  
Yasushi Hashimoto  
Honorary President of Japanese Soc. of Agricultural,  
Biological, Environmental Engineering & Scientists  
JAPAN

## Introduction: "Congratulation" !

President Yoshinori Kishida has developed "the Culture over Agricultural Machinery" especially in Asia, Africa and Latin America for this half century. Thus, "AMA" may be one of the most highest international journal, in addition, especially in the recent AI-ages of "Agricultural Science and Engineering".

By the way, I have been an international chairman for IFAC (control eng.)<sup>[1]</sup> over these 25 years. Through activities of IFAC, I have been intimate with Secretary General of CIGR. CIGR recognized Famous President Y. Kishioda as the one of key persons in the world in new agricultural public opinion

At CIGR Congress held at Milan in 1995, President Kishida and I were nominated as the important officer in CIGR. At that time, CIGR has been accepted by Science Council of Japan (Japanese Government) like IFAC, then we have been important colleagues in several academic activities through Japan as well as International Academies.

## Kishida International Prize in ASABE

On the other hand, ASABE (American Society of Agricultural

and Biological Engineers) is another big academic society in USA. Historically, "Kishida International Prize" is one of the most valuable awards in ASABE. In 2006, ten years after CIGR Milano Congress, I could get BIG-Awards from ASABE which was so called "Kishida-ASABE International AWARDS" at Portland in USA<sup>[2]</sup>, which was given based on the paradigm shift of "speaking plant approach" in greenhouse computer control (in the computerized agricultural system)<sup>[3]</sup>.

## "Paradigm Shift of Control in Greenhouse Engineering"

In IFAC Kyoto Congress (1981), special session for phytotronics was successfully organized by Prof. Hashimoto with the help of Prof. Alexander Udink ten Cate of Wageningen University as a co-organizer, as the first special session in the agricultural engineering in the world. After several mini-symposia in Netherlands, UK, and Germany, we could have "Technical Committee in Agricultural Engineering (TC in AE)" in 1990 at IFAC Tallinn Congress. The first Workshop on agricultural control problems at Matsuyama was held at ANA Hotel in 1991 based on IFAC rule<sup>[4]</sup>.

The concept of SPA (speaking plant approach) to environmental

control of the greenhouse) was supported by the TC as the paradigm shift of the Computer Control of Greenhouse in Agriculture and Horticulture, resulting my name as the initiator.

## "Information Technologiy" in EFITA (European Federation for Information Technology in Agriculture)

Prof. A. J. Udink-ten Cate of Wageningen University who was the co-organizer of IFAC-TC also developed Information Technology in agricultural engineering.

As the results, CIGR had to edit Handbook of Information Technology. President Prof. Munack had to obliged to edit the Handbook<sup>[5]</sup>, resulted in new paradigm .

## New Agricultural Mechanizations Appear in the New Paradigm

Agricultural Mechanization should be strongly supported based on System Control, Instrumentation, Information-Engineering, Bio Robotics, and Communication System in the ages of AI (Artificial Intelligence).

IFAC<sup>[3,4]</sup>, EFITA (European Federation for Information Technologiy)<sup>[5]</sup>,

CIGR<sup>[6]</sup>, of course, our Japanese Society (Japanese Soc. of Agricultural, Biological, Environmental Engineering & Scientists) may also shift the paradigm to new agricultural mechanization, such as Information Application consist of Control, AI, Biorobotics<sup>[7]</sup> in the basis of Recent Mechanical Engineering, strongly supported by honorary director of President Kishida as well in CIGR and IFAC.

Recent engineering may be paradigm shift by new methods developed in new measurement technologies. Accomplishment from the USA-Japan-Seminar supported by both NFS (National Foundation of Science in USA and JSPS (Japan Society of Promotion of Science) about new biological instrumentations may now easily accessible<sup>[8]</sup>.

Modern Information and Communication Systems in Agriculture, Food Production and Environmental Control, EFITA-1999//as the IFAC representatives: Prof. Dr. A. Udink-ten Cate (Wageningen, The Netherlands), Prof. Dr. Y. Hashimoto (Japan), p.431, 1999, Univ. Bohn, Germany.

[6] Munack. A ed.: CIGR Handbook of Agricultural Engineering VI (Information Technology) p.523, 2006, ASABE, (Hashimoto, as the member of Edit-Board).

[7] N. Noguchi, H. Murasee (Guest Eds): Special Issue on bio-robotics, "Computers and electronics in agriculture". 63(1), 2008, Elsevier.

[8] Y. Hashimoto et al., eds: Measurement Techniques in Plant Science, p.431, 1990, Academic Press, San Diego.

■ ■

## CIGR/KYOTO-Congress/2022

AMA! "paradigm shift of Agricultural Mechanization" in Asia, Africa and Latin America! Next target may be CIGR/Kyoto Congress, which Prof. Noguchi could organize with the enormous supports by the president Kishida. Á votre sante!

### REFERENCE:

- [1] Y. Hashimoto (guest ed): Applications of Artificial Neural Networks and Genetic Algorithms to Agricultural Systems, "Computers and Electronics in Agriculture". 18 (2, 3), 1997, Elsevier.
- [2] Y. Hashimoto: "Kishida International Award" in 2006, ASABE.
- [3] Y. Hashimoto et al., eds: The Computerized Greenhouse, p.331, 1993, Academic Press, San Diego.
- [4] Y. Hashimoto and W. Day, eds: Mathematical and Control Applications in Agriculture and Horticulture, p.447, 1991, Pergamon Press, Oxford.
- [5] Schiefer eds,: Perspectives of

### Yasushi Hashimoto

\*Personal Data: Born in 1936, Graduated: Univ. of Tokyo. (BS, MS, DS),

\*Visiting Prof.: Duke University, USA (1983), Wageningen Agric Univ. NL (1981),

\*Royal Soc. London (1983), K. U. Leuven. B (1991), Tokyo Agr Univ. (2002-2007)

\*IFAC WG chair (1980-1989), TC chair (1990-1996), CC chair & Technical Board (1996-2002), Council Member (2002-2005)

\*CIGR (chair of technical dev.II (1995-1998), chair of CIGR/Tsukuba Congress/2000

\*Chair (Japanese representative) of Joint Semina between USA & Japan in 1985), \*Science Council of Japan (member: 2000-2005) (assoc.mb (1985-2000, 2005-2017)

# Smart Agriculture for 9 Billion People's Food Production and Environmental Conservation Aiming SDGs



by  
Naoshi Kondo  
President  
Japanese Society of Agricultural Machinery and Food Engineers  
Professor, Kyoto University, Kyoto 606-8502  
JAPAN

## Introduction

It has been 50 years since the Farm Machinery Industrial Research Corporation published in 1971 the first AMA journal of Agricultural mechanization for developing countries. On behalf of JSAM (Japanese Society of Agricultural Machinery and Food Engineers), I would like to sincerely congratulate the AMA. I recall with admiration that during this half century the AMA journal received an Impact Factor rating (2012) from Thomson Reuters, USA, as well as reaching a worldwide audience.

Given the magnitude of this achievement in the field of agricultural machinery research, I would like to send congratulations to President Yoshisuke Kishida on the 50<sup>th</sup> anniversary of the company and to express my appreciation for his great contribution to this research field. It is no exaggeration to say that the current field of “Smart Agriculture”, as well as “Precision Agriculture” which preceded it, are a result, in no small way, to his continuous efforts to spread information and inspire many other researchers to contribute to the develop of these new fields through the company’s

newspaper and journal. As a measure of our gratitude, I would like to detail here this research and technological development. Our academic society, JSAM, is also indebted to him for his financial, as well as, intellectual support.

## Precision Agriculture and Smart Agriculture

**Fig. 1** illustrates the concept of Precision Agriculture (PA), which began being mentioned from the late 1990s. Compared with conventional agriculture, PA is based on multiple sources of data being received from sensing systems, providing information about soil, plant growth, climate and weather. The PA concept is said “to minimize investment while maximizing benefits based on information.” For example, farmers need not uniformly spread fertilizers on a field, if sensors identify those areas in most need.

In my opinion, the more recent concept of Smart Agriculture is similarly based on information that guides appropriate farming operations. Such Smart Agriculture will, however, require more sensors, AI (Artificial Intelligence), and robots.

In PA the linkage with machines or robots was not obligatory, but the sensors were needed to inform precise agricultural operations.

The PA concept evolved through to the middle of 2013, more recently integrating technologies, such as neural network based machine learning, use of IoT, sensors, and robots; resulting in the new term “Smart Agriculture”. We expect automation to expand even more as labor shortages increase and the demand worldwide for more efficient food production and environmentally conservative practices are sought.

Already we are being confronted with serious environmental problems: global warming, air and water pollution, water resource shortages, overuse of chemicals, and plastic pollution as the economies in many developing countries surge. Trade-offs between food production and environmental issues need to be solved simultaneously as the world population is expected increase to 9 billion by 2045.

## Solving the Trade-offs

Obviously, we will need to improve the productivity of both land



**Fig. 2** Separated orange fruits whose skins have slight injury fluorescing

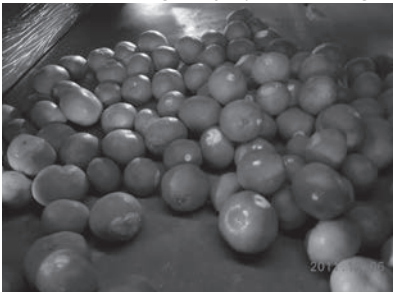

production and labor if we are to meet the food supply demands of two billion more people. Further mechanization and automation will play an important role in meeting these demands, as will selection of higher yielding cultivars. Witness to this, in 2017 Japanese companies started selling unmanned tractors. Automated rice transplanters and combine harvesters will also be available for practical paddy field operations in the near future. It will be possible to make an operator-plural machine system for Asian intensive agriculture which makes higher productivities as well as higher quality products.

Secondly, insect and pest crop losses will also need to be reduced. If we can detect product disease and insect injury at an early stage, we can effectively increase field productivity significantly. Recently, drone based crop monitoring sys-

tems have been developed using color/multispectral cameras. By autonomously controlling drones with cameras mounted on them, we could effectively monitor crops during the growing season, and thereby make large gains in the amount of product that makes it from the field to the consumers' table.

Thirdly, post-harvest losses can be reduced by introducing more sensitive grading machines into agricultural production. Even the slightest injury by bacteria can have deleterious effects during storage and distribution to retailers or the home.

Recent imaging technologies can detect injuries in the skin of citrus fruit, the size of a pinhole. When these citrus fruits are separated out, the healthy shelf-life of the remaining fruit are effectively increased. **Fig. 2** shows the fruit with pinholes and slight injuries separated out and highlighted using fluorescence imaging sensors at a grading facility. In the figure, the yellow portions on the skin are fluorescent substances released on to the surface of the skin after injury. If some of these fruit had been boxed together with healthy fruit prior to storage, the healthy fruit could be spoiled by the bacteria from the injured fruit.

Such fluorescence sensors could also be used in home refrigerators;

keeping a watch on the freshness of agricultural products, such as tomatoes and green peppers. They could help inform consumers which food needs to be consumed quickly and which can be safely saved for later consumption. It is said that 1.3 billion tons of food per year is lost in Japan; 30 % of all the food produced in that year.

As indicated above, new machines, devices and sensors for efficiently producing and conserving food and the surrounding environment need to be developed for application in open fields, controlled environments, post-harvest facilities, and at home. Of course, these technologies will not stop at just agricultural products, but must also cover livestock, aquaculture, food, as well as our own health (see **Fig. 3**). I believe the AMA journal will continue to contribute to the enhancement of these activities in "Smart Agriculture" by mitigating the multiple trade-offs inherent in the vision of JSAM members: "Food Production, Environmental Conservation, and Healthy and Affluent Human Life".

■ ■

**Fig. 1** Information flow based on the precision agriculture

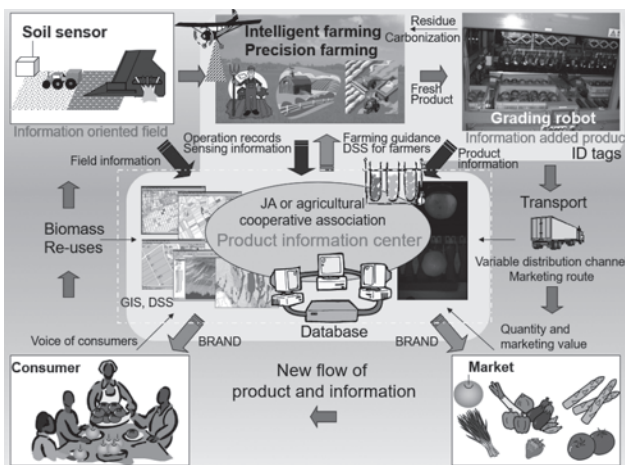

**Fig. 3** Our technologies on smart agriculture covering primary industry, food industry and health industry contribute to humans healthy and affluent life

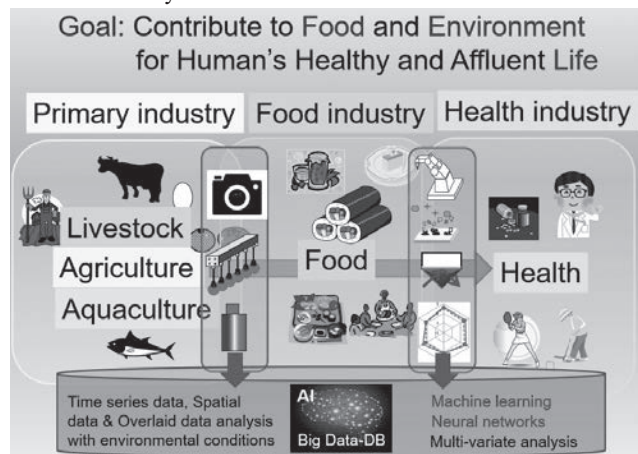

# Smart Robots for Production Agriculture for SDGs



by  
Noboru Noguchi  
Professor of Vehicle Robotics,  
Laboratory of Vehicle Robotics,  
Graduate School of Agriculture,  
Hokkaido University, Sapporo, JAPAN  
noguchi@cen.agr.hokudai.ac.jp

## Introduction

Being able to provide food for citizens will be a significant concern for governments in near future. Self-sufficiency in food is main criteria which countries will struggle with. It was estimated that the world population will increase to 11.8 billion until 2,100 (Statistical handbook of Japan, 2015). Supporting this population will not be possible if the long-term planning was not included in the future policies of the agriculture industry. Also, over the past few decades, the agriculture industry has faced new challenges. Previously, self-sufficiency in food, and rural migration to cities were the significant concerns. There are limited agricultural harvestable farms in the world which water crisis, labor shortage, natural phenomenon, and economic issues definitely will reduce the chance of the farming. The change of forests to agricultural fields will have irreversible consequences on the ecosystem, air pollution, and oxygen production.

In developed countries such as Japan and USA, the interest of younger generation in agriculture is steadily declining. This is because of low income of farmers in comparing by office works, the difficulty of farm work, and cultural attitude change. According to global agriculture statistics, the average age of farmers is 65.9 years (Statistical handbook of Japan, 2015), compared

to 55.9 years old in USA (USDA Farm Demographics, 2012), and 52 years old in Iran (Asadollahpour, et al., 2014). With a declining farming population, the majority of farmers are considered “too old” to handle the rigorous demands of the industry. According to the last report from the Statistics Bureau of Japan, the number of laborers continue to decrease, from 20.33 million (30.2% of total workers) to 13.40 million (3.7% of total workers) over the period from 1960 - 2013. This problem and others have had a negative effect on agricultural output, which was 8.47 trillion yen in 2013, down 0.7% from 2012. Furthermore, based on the Global Agricultural Productivity report, agricultural production needs to increase by 100% over the next 40 years. Doubling agricultural productivity from 2005 to 2050 is aligned with the SDG 2 target of doubling agricultural productivity and incomes of small-scale farmers and food producers (Global Agricultural Productivity Report, 2019). Now we can imagine that we will have fewer farmers with old age, limited farmland, water crisis, global warming, and population growth in the future which continually increase the complexity of the issue. This makes a multi-variable problem which the scientist has to solve by consideration of single answer: produce more food with limited resources.

In western countries, “sustainable agriculture” was developed to

reduce the environmental impact of production agriculture (National Research Council, 1997). At the same time, the global agricultural workforce continues to shrink; each worker is responsible for greater areas of land. Simply continuing the current trend toward larger and heavier equipment is not the solution. A new mode of thought, a new agricultural technology is required for the future. Intelligent robotic tractors are one potential solution (Noguchi et al., 1997). Sensors are an essential part of intelligent agricultural machinery. Machine vision, in particular, can supply information about current crop status, including maturity (Ahmad et al., 1999) and weed infestations (Tian et al., 1999). The information gathered through machine vision and other sensors such as GPS can be used to create field management schedules for chemical application, cultivation and harvest. This chapter will give the application of robot vehicles in agriculture using new technologies. Research institutions around the globe are conducting researches about autonomous vehicle for agricultural use and usually they rely on a RTK-GPS (real-time kinematic global positioning system), GIS (geographical information system), image sensors, and VRS (virtual reference station), etc. (Kondo et al, 2011). The most advanced technologies related an intelligent robot vehicle will be addressed here.

## A Robot Farming System

The robot farming system will fully automate the farming from planting to harvesting until to the end user of the products (Noguchi et al., 2011). A robot tractor and a planting robot will be used to plant and seed the crops using navigation sensors. A full overview of the robot farming system is shown in Fig. 1. It includes a robot management system, a real-time monitoring system, a navigation system, and a safety system. In the robot farming system, the robot vehicles receive a command from the control center and send information data through a wireless LAN or packet commu-

nication. The robot vehicles such as a robot tractor and a robot combine harvester can perform its designated tasks and can work simultaneously with each other. The operator at the control center can analyze the data sent by the robot vehicles in a real-time basis and can immediately send the necessary information to the farmers, retailers, and producer's cooperation, etc. Also, the operator can see the real-time status of the robot vehicles using a GIS while their performing its task.

### Agricultural Robot Vehicles

A wheel-type robot tractor and a crawler-type robot tractor developed in Hokkaido University, Japan and a

rice transplanting robot and a combine harvester robot developed by the National Agriculture and Food Research Organization (NARO) in Japan are discussed in this section.

#### i. Wheel-type Robot Tractor

The platform of the robot is a conventional 56 kW tractor (MD77, Kubota Ltd.) which was modified to utilize as the robot (Noguchi et al., 2002). Fig. 2 shows the hardware platform. The attached internal controller is built in the tractor cabin and control actuators for those functions. The internal communication is based on a serial, RS232C, while the communication between the PC and the internal controller is conducted through CAN-bus. The developed navigation system basically composed of "Mission planner" and "Autonomous operation" as described above. It enable to control the robot in terms of a hitch function, a power-take-off, an engine speed set, and a transmission etc. as well as steering angle during autonomous operation. This control is based on the posture information from the RTK-GPS and the IMU in reference with a navigation map. All stages of field work including tillage, seeding, tillage, spraying and harvesting, can be automated when the robot is equipped with a map of its travel path. Moreover, it is possible to automate the whole operation sequence completely since the robot can drive out of the machine shed by itself, travel along the farm road to the field, complete

Fig. 1 Overview of the robot farming system

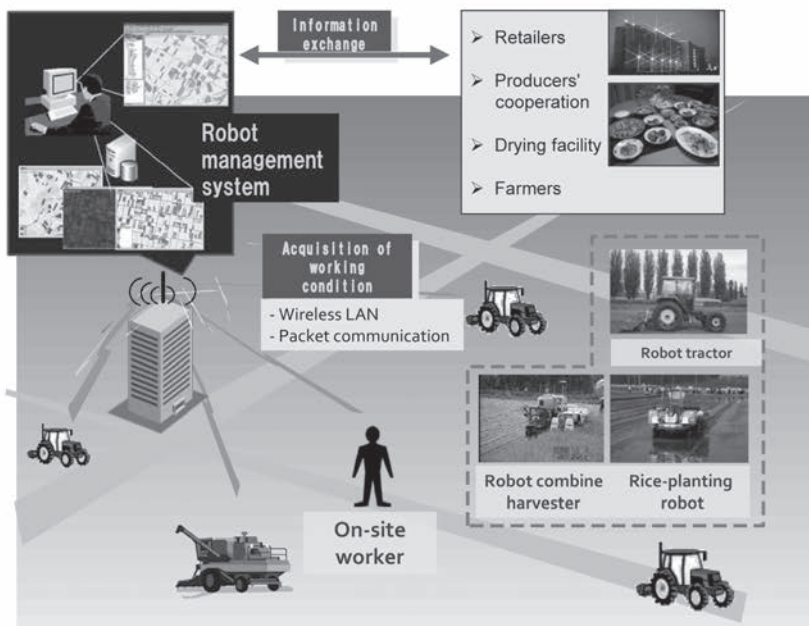

Fig. 2 Wheel-type robot tractor

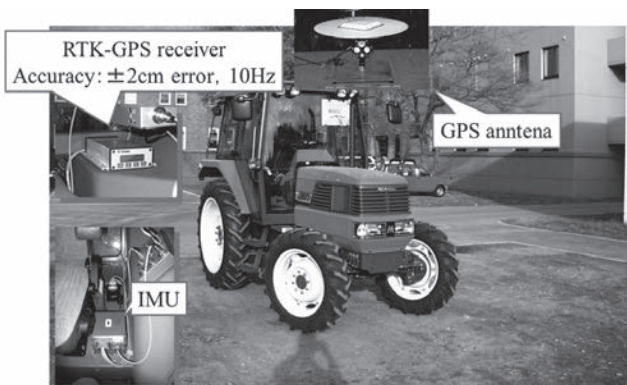
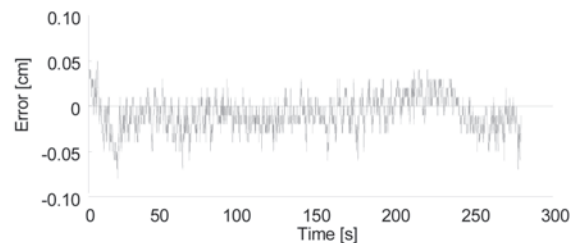

Fig. 3 Lateral offset of #1 pathway on sugar beat field



the required operation and return to the shed by itself. In other words, there is no need for an operator to transport such a robot to the field. The traveling accuracy of the robot is  $\pm 5$  cm, which is far more accurate than a human operator. The guidance system could follow the predetermined paths accurately. Fig. 3 shows the lateral offset on the robot splaying. The working distance for splaying was 280 m and the results are illustrated for the 1st path. As seen in the figure, the maximum error was 8 cm, and r.m.s. error was about 2 cm. The 2 cm error is accurate enough for field operations.

**ii. Crawler-type Robot Tractor**

Crawler tractors are widely used in agriculture because of the lower ground pressure and the higher traction efficiency compared to wheel-type tractors. A crawler tractor can be applied to the various field works such as tillage, cultivation and snow dispersal. The platform vehicle, a 59 kW crawler-type tractor (CT801, Yanmar ltd.) was modified. Actuators and an ECU (Electrical Control Unit) were built in the vehicle to electrically control the vehicle's HSTs (Hydro Static Transmission) (Zhang, 2009), hitch functions, power-take-off, and engine speed set. The RTK-GPS and the IMU were used as navigation sensors. Fig. 4 shows the schematic diagram of the system. The PC controlling the robot communicates with all ECUs through CAN (Controller

Area Network) bus. It enables the robot to control travel direction and speed by changing the positions of two HSTs, which have functions of shift and steering. Since the HST had strong nonlinear property against a control input (Rovira-Más et al., 2010), a nonlinear controller considering the HST property was developed. In addition, a function of map-base variable rate application of fertilizers and chemicals was implemented due to the CAN communication capability with a variable rate equipment. Fig. 5 shows a result of the robot run. In the headlands, the vehicle turned using a keyhole turning. The robot vehicle could follow the predetermined path with less than 5 cm of lateral error and less than 1 deg. of heading error.

**iii. Rice Transplanting Robot**

Fig. 6 shows a six-row rice transplanting robot developed in NARO, Japan (Nagasaka et al., 2004). It has been modified to perform completely automated operation with the addition of DC servo motors for operating the throttle, the gear transmission (CVT) and the implement clutch, proportional hydraulic valves for steering control, and hydraulic electromagnetic valves for operating the left and right brakes, clutches and the implement elevator. It also employs an RTK-GPS and an IMU as navigation sensors. In working situation of the robot, the steering angle is determined based on a

**Fig. 5** Trajectory of autonomous navigation

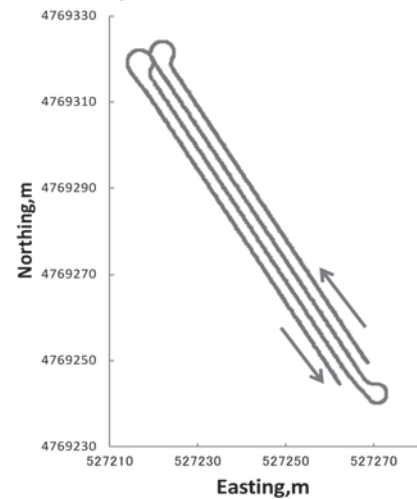

lateral error and heading error from the predetermined path and control signals are sent to the hydraulic valves. At the end of the field, the robot conducts keyhole turn to enter the next travel path.

The transplanting robot can travel within an error range of  $\pm 10$  cm from the predetermined path. Although rice seedlings must be supplied manually, the use of long-mat type hydroponic rice seedlings enables the robot to transplant up to 3,000 m<sup>2</sup> of land at a rate of 0.2 minutes/ha without replenishing seedlings as seen in Fig. 7.

**iv. Robot Combine Harvester**

A developed robot combine harvester in NARO, Japan is shown in Fig. 8. The base machine was a 26 kW combine harvester (HC350,

**Fig. 4** Schematic diagram of the crawler-type robot tractor

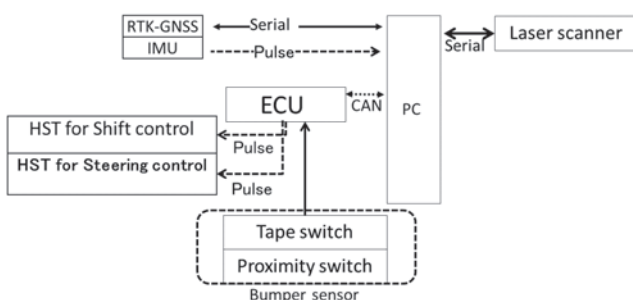

**Fig. 6** Rice planting robot



**Fig. 8** Robot combine harvester

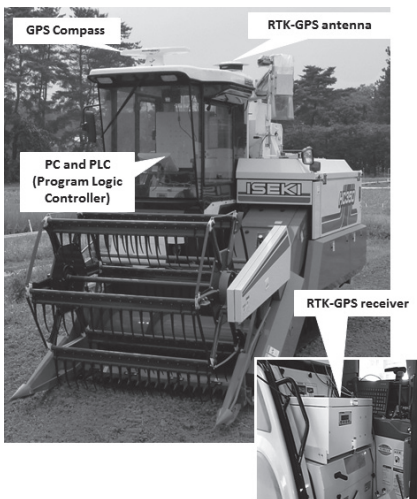

ISEKI Ltd.). An RTK-GPS and a GPS compass (V100, Hemisphere) substituting an IMU are used as navigation sensors. The GPS compass gives absolute heading angle with accuracy of 0.3 deg. The robot has general functions on a combine harvester such as a speed control, a header height control, and an auto level system, etc.

**Fig. 9** shows a trajectory of the robot combine harvester on a wheat field. The field size was 30,000 m<sup>2</sup>

and work speed was 0.6 m/s. First three round paths from the outside of the field were harvested by human drive, and the rest of field was square harvested with cross land by the robot. A lateral error of the robot operation was about 7.1 cm. This error was acceptable as guidance performance because a row width of wheat is 30 cm.

**Obstacle Sensor**

There are some unresolved issues for automated agriculture using robots. One is the issue of how to ensure safety, both for the operator and in the space around the robot. The awareness of safety is particularly high in the U.S. Even the standard tractors are equipped with a safety mechanism which prevents the vehicle from moving unless the operator is sitting in the seat. Naturally, a higher level of safety assurance is required for a robot which operates without an operator.

A successful sensor units detecting an obstacle using a 2D scanning laser for a robot tractor is explained here (Noguchi et al., 2011). Since it is necessary to fit the robot with a

multiple-stage and redundant safety system. Three types of obstacle detection sensors have been implemented in the robot tractor.

Bosch Cooperation has been developing the obstacle detection sensor unit composed of various sensors used in automobiles. According to investigation about an unmanned ground vehicle (UGV) used in real world such as an unmanned transport vehicle in a factory, the obstacle detection sensor's specification is made. The sensor covers all direction surrounding the robot vehicle by integrating a radar, vision and ultrasonic sensor shown in **Fig. 10**. The sensor unit has a function of making decision of safe or danger of collision based on multiple sensor input. However, the level of safety that needs to be achieved before a robot can be released on the market is not just a technological question but also a question which requires community consensus. If the robot must take full responsibility in the unlikely event of an accident, it will lead to an enormous cost increase and hinder the progress of robotization. There is a need for discussion and consensus-building with regard to the sharing of responsibility between users and manufacturers.

**Fig. 7** Trajectory of a rice planting robot

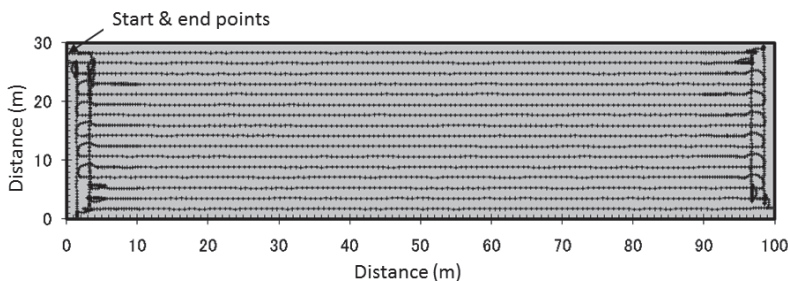

**Fig. 9** Trajectory of the robot combine harvester

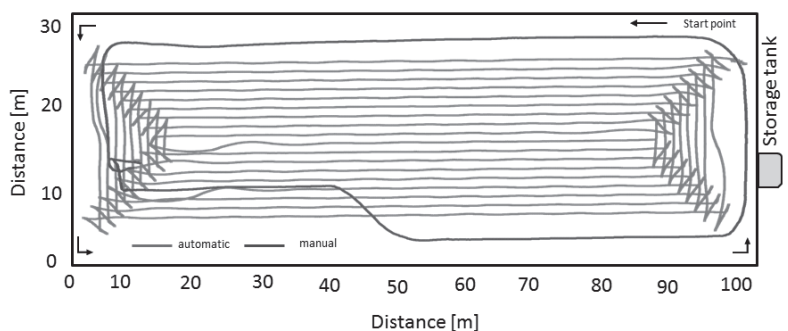

**Robot Management System**

One of the important parts of the robot farming system is a management system for robots. A robot management system is developed based on an integrated agricultural GIS commercialized by the Hitachi Solutions Ltd. (Yamagata, 2011) The GIS can handle various types of data such as field information, crop type, soil type, yields, quality, farmer's information, chemical cost, and fertilizer, etc. Users can handle these informations through unified operations. This GIS-base robot management system has a function of communicating with the robot vehicles about status of the work such as work efficiency and the level of fuel, fertilizer and chemicals con-

tained in each tank. The robot management system can also obtain crop information data from the robot vehicles using a smart vision sensor explained in the next section. From this information, a variable rate fertilizing map can be generated and the control center can send it back to the robot tractors for fertilization of the crops. **Fig. 11** shows the mission plan map. Another function of the robot management system is the real-time monitoring of the robot vehicles while in working condition. In the case of the combine harvester robot, each field is colored according to its harvest status: not harvested, now harvesting, or harvested. Using this management system, the current location and status of the robot vehicles can be seen. Also, the current information of the working condition of the robot vehicles can also be observed. **Fig. 12** shows the real-time monitoring system of the robot vehicle. In the figure, each working robot has its own Robot ID. By clicking the Robot ID to the computer screen, details about the robot vehicle will be seen.

## Conclusions

Increases in the productivity of

agriculture have resulted in a decline in the skilled machine operator work force, particularly in advanced countries. The average age of the agricultural workforce is increasing, indicating that this profession is not being passed on to the younger generations. On the other hand, soil compaction by very large tractors and other farm machinery, environmental pollution by excessive use of agricultural chemicals and fertilizers, and concerns about food safety; these negative outcomes of our single-minded pursuit of higher productivity are manifesting themselves. It can be said that in order to solve the food-related problems currently facing human kind, we are in need of production support in the form of not only powerful tractors and other machinery but also more sophisticated tools that can perform tasks with human-like finesse. Humans use a significant amount of intelligence to combine job functions, visual and audio cues, motion sensations, and experience to maneuver the agricultural equipment like a tractor. The intelligent robot as a substitute for human workers involved in food production will be an indispensable system for the infrastructure for human survival in the future.

**Fig. 10** Safety sensor for an agricultural robot vehicle

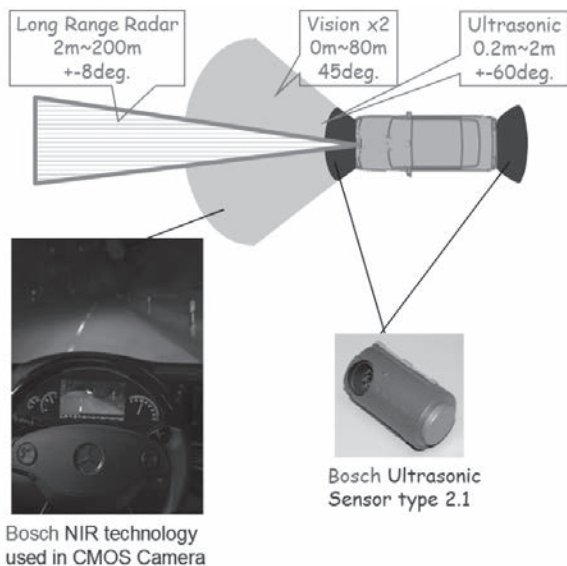

**Fig. 11** Mission plan map in robot management system vehicle

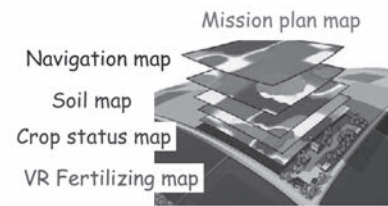

## REFERENCES

- Statistical handbook of Japan 2015, Statistics Bureau Ministry of Internal Affairs and Communications Japan.
- USDA. Farm Demographics - U.S. Farmers by Gender, Age, Race, Ethnicity, and More. In. 2012.
- Asadollahpour, A., Omidinajafabadi, M. and Jamalhosseini, S. 2014. Factors affecting the conversion to organic farming in Iran: A case study of mazandaran rice producers. *Science International (Lahore)* 2014; 26: 1844-1860.
- Global Agricultural Productivity Report 2019. Virginia Tech College of Agriculture and Life Sciences.
- Ahmad, I. S., Reid, J. F., Noguchi, N. and Hansen, A. C. 1999. "Nitrogen sensing for precision agriculture using chlorophyll maps," ASAE Paper, 993035.
- Kondo, N., Monta, M. and Noguchi, N. 2011. *Agricultural robots -Mechanisms and Practice-*, Kyoto University Press.
- Nagasaka, Y., Umeda, N., Kanetai, Y., Taniwaki, K. and Sasaki, Y. 2004. "Autonomous guidance for rice transplanting using global

**Fig. 12** Real-time monitoring system



- positioning and gyroscopes,” *Computers and Electronics in Agriculture*, 43, 223-234.
- National Research Council. 1997. *Precision agriculture in the 21<sup>st</sup> century*, National academy press. Washington D.C.
- Noguchi, N., Ishii, K. and Terao, H. 1997. “Development of an agricultural mobile robot using a geomagnetic direction sensor and image sensors”, *Journal of Agricultural Engineering Research*, 67(1), 1-15.
- Noguchi, N., Kise, M., Ishii, K. and Terao, H. 2002.” Field automation using robot tractor”, *Proceedings of automation technology for off-road equipment*, 239-245.
- Noguchi, N., Will, J., Reid, J. and Zhang, Q. 2004. “Development of a Master-slave Robot System for Farm Operations”, *Computers and Electronics in Agriculture*, 44(1), 1-19.
- Noguchi, N. and Barawid, O. 2011. ”Robot farming system using multiple robot tractors in Japan agriculture”, *Preprints of the 18th IFAC World Congress Paper*, No. 3838.
- Reid, J. F., Zhang, Q., Noguchi, N. and Dickson, M. 2000. “Agricultural automatic guidance research in North America”, *Computers and Electronics in Agriculture*, 25, 155-167.
- Rovira Más, F., Zhang, Q. and Hansen, A. C. 2010. “Mechatronics and intelligent systems for off-road vehicles”. Springer.
- Takai, R., Noguchi, N. and Ishii, K. 2011. “Autonomous navigation system of crawler-type robot tractor”, *Preprints of the 18<sup>th</sup> IFAC World Congress*, Paper No. 3355.
- Tian, L. F., Reid, J. F. and Hummel, J. W. 1999. ”Development of a precision sprayer for site specific weed management”, *Transaction of the ASAE*, 42(4), 893-900.
- Yamagata, N. 2011. ”The integrated agricultural GIS: GeoMotion Farm”, *Proceedings of 4<sup>th</sup> Asian Conference on Precision Agriculture*, O-32.
- Zhang, Q. 2009. *Basics of hydraulic systems*. CRC press.

■ ■

## EVENT CALENDAR

2021

◆ **EIMA International**

*October 19-23, Bologna, ITALY*  
<https://www.eima.it/>

◆ **AGRO Ciencias 2021**

The Agrarian University of Havana (UNAH), in the framework of its 45<sup>th</sup> anniversary, is pleased to invite you to the International Congress of Agricultural Sciences (AGROCIENCIAS), which will be held at *the Palace of Conventions in Havana, Cuba, in May 17-21, 2021*.

2022

◆ **SIMA**

*November 6-10, Paris Nord - Villepinte, FRANCE*  
<https://simaonline.com/>

■ ■

# Digital Farming Strategy toward Agricultural Transformation



by  
Sakae Shibusawa  
Professor Emeritus  
Tokyo University of Agriculture and Technology,  
Tokyo, JAPAN  
Council Member, Science Council of Japan  
Secretary General, Science Council of Asia

## Abstract

This is an article for the 50<sup>th</sup> anniversary of the AMA journal publishment, focusing on the future shape of digital farming. The digital farming is the latest stage of modern agriculture, which let us lead the question “who makes decision on farm management with the data?” Exploration for answering to the question needs at least two storyboards of thinking: farm work mechanization and farm work decision in physical space and cyber space. Typical topics introduced here are: digital technology changes the farm work, management strategy in precision agriculture, digital farming scheme and target, cyber-physical farming system for agricultural transformation. These topics will help the readers to explore the future farming in countries.

**Keywords:** precision management, community-based, cyber-physical farming, mechanization

## Introduction

The author would like to celebrate the 50<sup>th</sup> anniversary of AMA journal, which has been encouraging and inspiring people who have devoted to the agricultural mechanization and development

in Asian countries. Looking at the last 50 years, it started from 1971, and also looking at the coming 30 years, strong impacts of info-tech and bio-tech are found over all field and discipline under the change of social foundation. Moreover, in the year 2020 the COVID-19 pandemic has changed the whole lifestyle and social system in the world.

Population decreasing society has come in Japan with lots of new complex issues, such as shrinks of local community and industry. All Asian country follows Japan in the coming 30 years. Community-based approaches were useful to combat against such complex or trade-off issues in the fields of not only agriculture but also local society (Shibusawa, 2015).

Such problems complex and trade-off, such as the environment, energy, water, food and poverty, have become global issues and totalized as the SDGs Sustainable Development Goals for “Transforming Our World: The 2030 Agenda for Sustainable Development” by the United Nations in 2015. The SDGs are the 17 goals and 169 targets to achieve by the year 2030 to end poverty, protect the planet and ensure prosperity for all as part of a new sustainable development agenda. Achieving the SDGs requires the partnership of governments, private

sector, civil society and citizens alike to make sure we leave a better planet for future generations. Agricultural sectors have indeed important roles for achieving it.

Systems are changing in the sectors of not only industry but also administration during the last five years (Shibusawa, 2016b). Smart society 5.0 was a phrase of target in the 5<sup>th</sup> 5-year basic program for science and technology innovation in Japan (CSTI 2016), which involved 11 sub-programs and two of them covered agricultural sectors: a smart food chain system and a smart agricultural production system. This implies that the agricultural issues became critical in the government policy of Japan, such as losing expert skills and knowledge, less new-coming young farmers, frequent damages by natural disasters, and market pressures of consumers’ motivations.

In the other hand Japanese industry and economy has experienced long-term depression effects and a new break-through event has been expected. The agriculture has got interest of people as a new frontier of industry innovation, and that is why advanced technologies were expected to be applied into agricultural sectors. The STI program has promoted the innovation in agriculture and related business fields. People called the new proj-



ects by phrases “smart agriculture” and “smart food chain”. Goals of the projects tended to be shown by different terminology, such as “cost-effective and market-in farm management”, “restoring/rehabilitation from disasters”, “agro-medical foods for health and life”, “water conservation agriculture”, and “STI has oriented SDGs practices”.

The ICT strategy of agriculture was also issued by the government to enhance the interoperability and portability of data/information (SHIT, 2014), which has encouraged the inter-ministry projects and activities as well as the collaboration between different sectors of industry. An idea of agro-medical foods was also re-organized in 2016 to expand the fields of precision agriculture (Shibusawa, 2016a).

The objective of the paper is to introduce current trends in precision/smart agriculture focusing on the science and technology innovation program, towards agricultural transformation.

## Digital Technology Changes Farm Work

Transborder farming implies here a system of farm management practices in communicating across the borders of different disciplines or different business sectors, and creating multiple functions and/or values by a single action. For example, a

person or machine works on a single job action such harvest with the monitor of the process, which used to produce both the output of the work and the information on the process of job. The farm work should be usually done to get high yield under constraints of regulations such as protection of contamination and labour safety. When the innovative technologies, such ICT, internet of things (IoT), artificial intelligence (AI) and robotics (RT), are introduced into the farm practices, a cyber space of the data is also produced at the same time through the practices, which plays multiple roles in a single action as shown in **Fig. 1**.

When the data and information are used for throughput management, the system of farm practices is re-defined as precision agriculture. When the data and information are used for risk management, the system of farm practices is re-defined as good agricultural practices (GAPs). When the GAPs follow the GLOBALG.A.P. Standards, the system of farm practices directly communicates with retailers, and furthermore communicates with consumers through the products accompanied with further constraints of food liability, food security, and food quality.

## Management Strategy in Precision Agriculture

Prior to describe the management

strategy, it had better to confirm the definition of precision agriculture and smart agriculture as follows. The reader can see they have no difference.

Precision Agriculture is a management strategy that gathers, processes and analyzes temporal, spatial and individual data and combines it with other information to support management decisions according to estimated variability for improved resource use efficiency, productivity, quality, profitability and sustainability of agricultural production. In succinct version, Precision Agriculture is a management strategy that takes account of temporal and spatial variability to improve sustainability of agricultural production. (<https://www.ispag.org/about/definition>, 2020).

Smart agriculture is the use of new advanced technologies within the agro-food system to promote sustainable productivity by allowing farmers and other stakeholders to make more informed, appropriate decisions. Existing and emerging technologies like big data, online meteorological data, digital technologies, and analytics are important components of smart agriculture technologies (APO Agricultural Transformation Framework, 2019).

In the last decade of field experiments working with farmers in Japan, four levels of data management strategy were recognized as shown in **Fig. 2** (Shibusawa, 2018).

**Fig. 1** Farm work provides simultaneous multi-functions by digital technology



**Fig. 2** Four phases of precision management practices

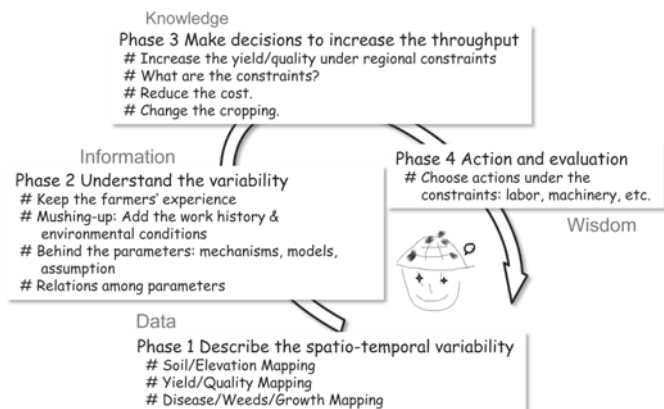

Level 1 was to simply describe the spatio-temporal variability of the fields, such as soil/elevation mapping, yield/quality mapping, disease/weeds/growth mapping, and then to recognize the evidence. The data set of time, location and evidence play the main role. Level 2 was to understand why the variability came out, with help of farmers' knowledge, mashing up of the data on the work history, the environmental conditions, and analysis the mechanisms behind, models and assumption. Prediction/exploration plays the main role. Level 3 was to make decisions in order to increase the throughputs, looking at increases in the yield/quality under regional constraints, and reducing the cost, or sometimes changes of the cropping system. Level 4 was the action and evaluation in a holistic view, such as to choose a system of actions under the constraints of labor, machinery, etc.

Based on the management strategy, community-based precision agriculture can be organized as a holistic management scheme of rural agriculture, including small farms, local industry and food chain, with help of new development on data science and technology. There are different stories regarding the practice of management in action when one looks at field variability on different scales. On a single small

farm, the farmer can better understand what is going on in each field, which enables variable-rate application for site-specific requirements with farmer's knowledge and skills. When it comes to covering an area of a few tens of hectares including lots of small fields, for example, a farm work contractor or company has to manage regional variability due to cropping diversity. They also have to coordinate the farmers with different motivations due to different cropping styles. Here, we have hierarchical variability: within field, between field, and between motivations of farmers in different scales and different cropping styles.

### Digital Farming Scheme and Target

Disaster recovering should be a target to apply the digital farming approaches. People in Japan have experienced big natural disasters with more than 50 deaths every three years and more than 100 deaths every 6 years during the last thirty years, followed by restoring measures of the community and agriculture. So to speak, it is Disaster Society Japan. For example, 1993 Hokkaido earthquake & Tsunami with 202 deaths, 1995 Hanshin-Awaji earthquake with 6,443 deaths, 2006 Heavy snowfall with 150

deaths, 2011 East Japan earthquake & tsunami with 2,668 deaths, 2018 West Japan heavy rainfall with 200 deaths. A long-term recovering measures required many kinds of technology and management, which often emerged new technology in situ (Fig. 3).

Southeast Asian countries also have many natural disasters. These disasters destroyed whole fields and villages, and then people have to reconstruct the agriculture and community with something changes to be better. Food chain is one of the most important lifelines to be simultaneously recovered in terms of food quality, food quantity and systems reliability.

National policy influenced the shape of domestic farming style and in particular the national science policy has depicted the digital farming scheme at the first time in Japan. The Council of Science and Technology Innovation (CSTI), Cabinet Office, Japan, has issued the 5th basic program for science and technology on January 19, 2016, and the innovative technologies were targeted as Smart Society 5.0 Service Platform. The 11 sub-systems or core programs were organized, including two programs in the agricultural sector, smart food chain system and smart production system.

The smart food chain system

Fig. 3 Disasters society makes unexpected changes in the shape of agriculture.

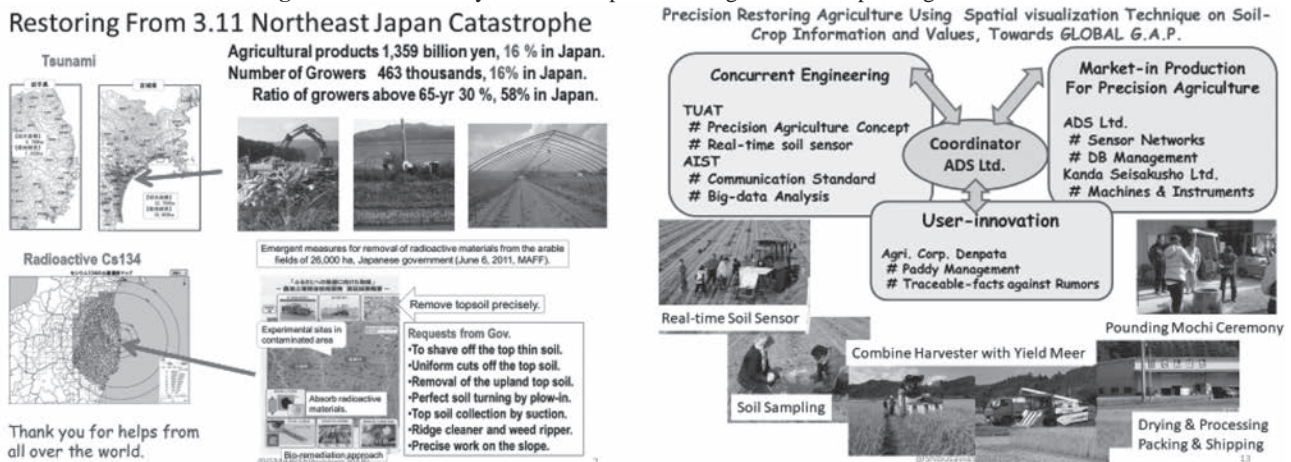

**Left:** Arable land recovering from disasters by big earthquake, Tsunami and nuclear plant explosion.  
**Right:** Digital farm works against the rumor damage, not for the yield increase...

should be worthy of note, and it is composed of four main sub-systems of breeding industry, growers organization of production, processing companies, transportation business and market needs of consumers as shown in Fig. 4. These events are letting people attract to farm works creating information, profits and risks at the same time. Information or digital data is becoming a new attractor of not only academia but also industry issues on such decision making, skill transfer, education, risk communication, and so on.

An ICT strategy, as shown in Fig. 5, was also issued from the government to enhance the competitive-

ness in agricultural activities, par-agriculture industry and marketing activities, by accelerating the creation and application of agricultural information. Interoperability and portability are required for active users to cost-effectively handle the data and information of the field. The strategy focused on standardization of data/information protocol, commonly available terminology to share the information across the inter-industry and inter-ministry sectors. Intellectual properties are also managed for growers and companies. Consequently, a local industry of agriculture will be changed into a globally active player.

Interoperability and portability are implied as illustrated in Fig. 6. The interoperability is here that the data or information accumulated can be used in different application or operation systems through a common protocol of data handling. Figure 6 shows examples of mutual utilization of data among other farmer's system, among other agricultural machines, among different vender services, and among other control systems. For the portability, examples are a new application system can continuously handle the data in a previously used system by files downloaded, and any application system can refer the data used in a previous system. The portability implies here that users can handle their own database in any application system.

Fig. 4 A vision of smart food chain (Local Resources Strategy Committee, Council for Science and Technology Innovation, 2015)



Fig. 5 Strategy for creation and application of agricultural information (The Strategic Headquarters for the Advanced Information and Telecommunications Network Society, Cabinet Secretariat, Japan. 2014.6.3)

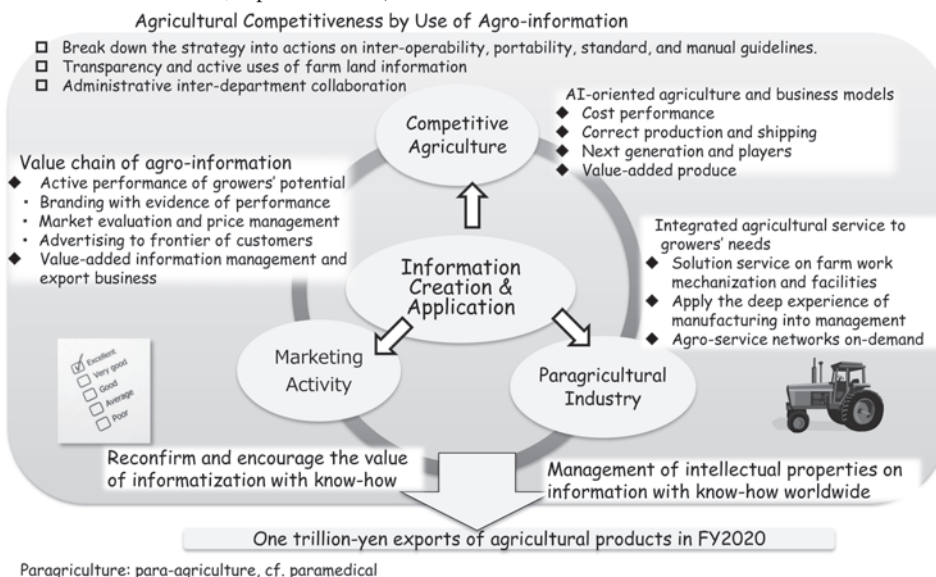

### Cyber-physical Farming System

If all risk is described, a forward-controlled crop management will be designed. Breeder fixes a crop variety with promised yield and quality under expected conditions or constraints, together with digital data chart, that is, a seed variety with growth data predictive. When a grower gets the seeds or seedlings, what one can do is to monitor the cultivation conditions or constrains and work practices timely or not. The risk is a gap of physical states to the promised states in a spatio-temporal coordinate system. When the risks are evaluated at a location and at a time, a loss of yield or quality is predicted at any time. With this information the plan of crop management could be changed or revised toward a better result at any time.

Extending the risk-oriented crop management model let us to have a cyber-physical farming system CPFS as shown in Fig. 7. The CPFS is composed of a physical

farm, a cyber farm, and its interface system. The physical farm is a real existing farm with management by a real people such farm managers and decision makers who collects the data and information on crops, fields, technology, regional constraints, and famers' motivations. Putting all data of the physical farm into a cyber space can construct a prototype of the cyber farm, which is enriched with the accumulation of data and information. When some simulation of physical farm events is conducted, the cyber farm develops onto the next stage. The interface system is a system of data collection, transfer and processing works, with data format standards and application programming interface (API).

Human factors are very important but missing parts in the CPFS. In the physical farm the decision making process of person is not described perfectly yet and a data sharing system of interoperability and portability just begins now. In the cyber farm reconstructing the real world is not developed yet and in particular the artificial brain and life to make decision is not tried. Communication of decision-making person on organic brains and silicon brains could be coming in the next 50 years.

## Conclusions

Precision agriculture has induced the process innovation of farm practices in communication with different sectors of industry. Community-based approaches with precision management will provide the next players for agricultural transformation. An idea of cyber-physical farming system gives a way of thinking how the society accepts the new technology and systems in future.

## REFERENCES

Council of Science and Technology Innovation (CSTI), Cabinet Office, Japan. 2016.1.19. The 5th basic program for science and technology. <http://www8.cao.go.jp/cstp/kihonkeikaku/index5.html> (in Japanese).

Kodaira, M. and Shibusawa, S. 2013. Using a mobile real-time soil visible-near infrared sensor for high resolution soil property mapping' *Geoderma*, vol. 199, pp. 64-79

Shibusawa, S. 2015. Systems Approach to Community-based Precision Agriculture, Chapter 7 in *Precision Agriculture Technology for Crop Farming*, Ed. Qin Zhang,

CRC Press, p360: 213-229.

Shibusawa, S. 2016a. Agro-medical foods strategy based on smart food chains. *Proceedings of the 8th International Symposium on Machinery and Mechatronics for Agriculture and Biosystems Engineering (ISMAB)*, 23-26 May 2016, Niigata, Japan: 768-771.

Shibusawa, S. 2016b. A context changing with precision agriculture in japan. *Proceedings of the 13th International Conference on Precision Agriculture*. July 31-August 4, St. Luis, Missouri, USA.

Shibusawa, S. 2018. A precision management strategy on soil mapping. *Proceedings of the 14th International Conference on Precision Agriculture*. June 24-27, Montreal, Quebec, Canada.

Strategic Headquarters for the Advanced Information and Telecommunications Network Society (SHIT), Cabinet Secretariat, Japan. 2014.6.3. Strategy and guidelines for creation and application of agricultural information. [http://www.kantei.go.jp/jp/singi/it2/senmon\\_bunka/nougyou.html](http://www.kantei.go.jp/jp/singi/it2/senmon_bunka/nougyou.html) (in Japanese)

■ ■

**Fig. 6** System image experienced by farmers of Honjo Precision Farming Society in 2018

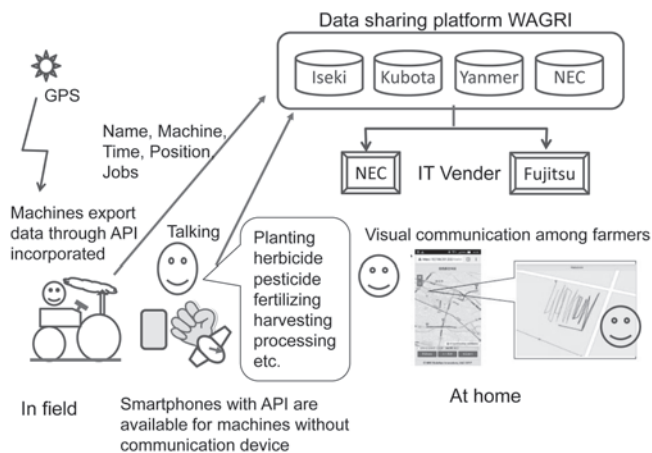

**Fig. 7** Storyboards of Cyber-Physical Farming System

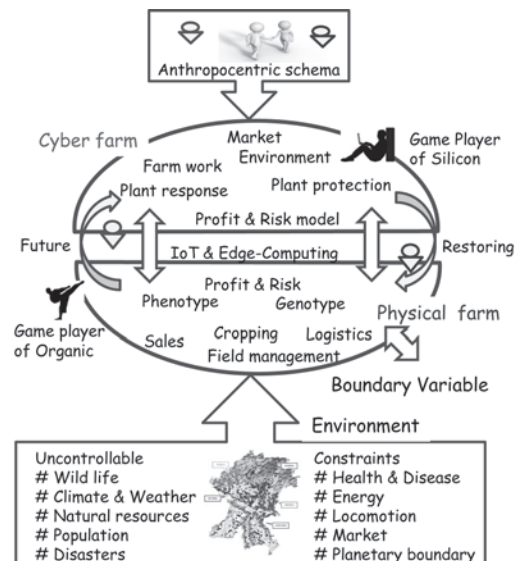

# Mechanization, Digitizing and Innovations in Agriculture



by  
Teruaki Nanseki  
President of Japan Society of Agricultural Informatics,  
Professor, Kyushu University  
JAPAN

The preface of the first issue (1971) of AMA stated “Agricultural mechanization is urgently needed not only for farmers but also for every people in this world. But it does not seem to be clear as a general consensus still.” After 50 years, it has been a general consensus in 2020. We are sure that AMA significantly contributes to this big change. This has been possible by cool head but warm heart of Dr. Yoshisuke Kishida as the founder of AMA, President, Shin-Norinsha Co., Ltd. as well as President and Editor in Chief, Farm Machinery Industrial Research Corp. We sincerely congratulate AMA on its

50<sup>th</sup> anniversary. And we hope that AMA will continue to contribute to agricultural mechanization in the world not only in Asia, Africa, and Latin America in the future.

In recent years, digitizing agriculture becomes to be an important concept to realize innovation in Agriculture as well as other industry. In this context, mechanization is still an essential element of agricultural innovation. One of the good examples to demonstrate this may be EFITA 2019. EFITA (European Federation for Information Technology in Agriculture, Food and the Environment) is biennial conference that facilitates participants from over 25

countries focusing on knowledge sharing and thinking on the future of ICT technologies within the agri-food and bio-resource sectors. The web site shows the 4 important elements of digitizing agriculture (**Fig. 1**). These are sensors, data, decision and action. The action includes real farm operations, such as tilling, seeding, fertilizing, harvesting, and etc. Without mechanization, digitizing agriculture do not work well in real farm operation.

At beginning of digital agriculture, for example, a tractor is improved by ICT. This becomes smart tractor. At next stage, several machines and sensors are connected. Then farm equipment system including tractors, tillers, planters and combine harvesters is organized. Finally, system of system including farm equipment system, weather data system, seed optimization system, irrigation system as well as farm management systems, is established. This is a good example of digital transformation process in agriculture as shown in **Fig. 2**. These indicate that at every stage of digital transformation process, farm Agricultural machines are important to conduct operations in real farms. At final stage, all machines will be connected to the system of system.

We should reconfirm that innovation do not mean just technical

**Fig. 1** Elements of digitizing agriculture



sensors



data



decision



action

Source: EFITA 2019 Web site

Fig. 2 Example of digital transformation process

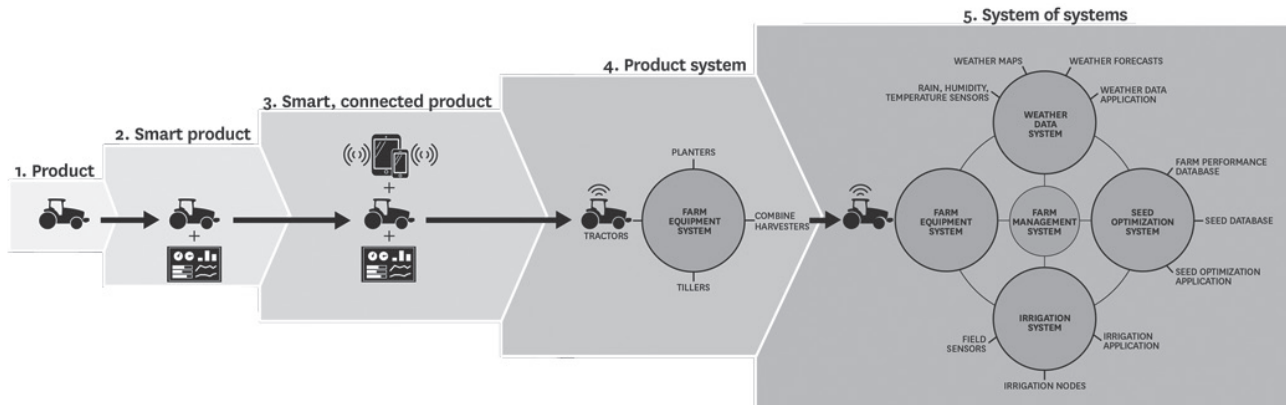

Source: M. E. Porter, J. E. Heppelmann (2014), Harvard Business Review

innovation and many of innovations are realized from business process innovation. In OECD Oslo manual (2018), it is defined as “An innovation is a new or improved product or process (or combination thereof) that differs significantly from the unit’s previous products or processes and that has been made available to potential users (product) or brought into use by the unit

(process)”. And a business process innovation includes production of goods and services distribution and logistics, marketing and sales, information and communication systems, administration and management, product and business process development.

Information and communication systems are recognized as most important key element for innova-

tion in recently. Thus digital-based innovations will contribute to realization of digital transformation and achievement of the SDGs. To achieve this, AMA is expected to continuously play an important role to stimulate and encouragement farms, agricultural machinery companies and researchers in the future. ■■

(Continued from page63)

## Agricultural Mechanization in the United States of America

ral/article/view/491  
 Renius, K. Th. 2020. Fundamentals of Tractor Design. Springer Nature: Cham, Switzerland.  
 Schimmelpfenning, David. 2016. Farm Profits and Adoption of Precision Agriculture. ERR-217. U. S. Department of Agriculture. Economic Research Service.  
 Schueller, J. K. 1992. A review and integrating analysis of spatially-variable control of crop production. Fertilizer Research. 33:1-34.  
 Schueller, J. K. 2000. In the service of abundance: Agricultural mechanization provided the nour-

ishment for the 20<sup>th</sup> century’s extraordinary growth. Mechanical Engineering 122(8): 58-65.  
 Schueller, J. K. 2002. A lifetime of lessons. Resource. 9(3): 11-12.  
 Searcy, S. W., Schueller, J. K., Bae, Y. H., Borgelt, S. C. and Stout, B. A. 1989. Mapping of spatially-variable yield during grain combining. Transactions of the ASAE. 32(3): 826-829.  
 Solon, Olivia. 2017. A right to repair: why Nebraska farmers are taking on John Deere and Apple. www.theguardian.com. posted 6 March 2017. accessed 24 June

2020.  
 USDA. 2019. 2017 Census of Agriculture. United States Summary and State Data. United States Department of Agriculture. April.  
 Whitney, J. D., Miller, W. M., Wheaton, T. A., Salyani, M. and Schueller, J. K. 1999. Precision farming applications in Florida citrus. Applied Engineering in Agriculture. 15(5): 399-403. ■■

# Need for Mechanization of Agriculture with Environmental Protection in Developing Countries



by  
Kenji Omasa

Dean, Professor, Faculty of Agriculture,  
Takasaki University of Health and Welfare.  
Professor Emeritus, The University of Tokyo.  
Member of Science Council of Japan.  
JAPAN

Congratulations to the AMA on its 50<sup>th</sup> anniversary! The AMA was first published in 1971 to focus on agricultural mechanization in Southeast Asia, but later, due to the request of its readers, it became an academic journal “Agricultural Mechanization in Asia, Africa and Latin America” for the developing countries of the world. AMA has made immeasurable contributions in the agricultural mechanization of developing countries since then.

I was honored to be asked to contribute to AMA’s 50<sup>th</sup> anniversary issue on “SDGs and Agricultural Mechanization in the World” by Mr. Yoshisuke Kishida, President of Shin-Norinsha, Co., which publishes AMA. The SDGs are the international goals for the year 2030 for the sustainable prosperity of humanity and the globe, which were adopted by the United Nations General Assembly in 2015 and are listed in the “2030 Agenda for Sustainable Development”. The goals of SDGs are for human beings to overcome poverty and hunger and enjoy prosperous and fulfilling lives through technological progress, while achieving economic, social and environmental harmony. In particular, it is characterized by a back casting approach, one that incorporates both a strong future vision and an examination of

how to bridge the gap between that vision and the present situation.

It is necessary to promote the mechanization of agriculture with environmental protection in developing countries to achieve the SDGs goals of ensuring agricultural production to meet the needs of the world’s growing population and improved livelihoods in the future, while at the same time preserving the global environment. Particularly, it is important to enhance the functions of agricultural machinery using intelligent robots, not only to automate tasks and increase yields, but also to reduce the environmental impacts on water, air and soil, to conserve the natural environment, and to achieve harmony between production and the environment. In addition, the use of renewable energy and the establishment of recycle-based agricultural production systems are also necessary. Furthermore, it is desirable to build a recycling-oriented society to manage the entire process from production to processing, distribution, sale and consumption as a system, and to reduce food loss and make effective use of it. In order to achieve this goal, networking of people, goods, and information is essential, even in developing countries. There are great expectations for the AMA

which can be a great information source in this area. ■■

# Overseas Expansion of Japanese Agricultural Machinery through Cooperation with International Cooperation Agency



by  
Hideo Hasegawa  
Ph.D., Professor  
Institute of Science and Technology, Niigata University.  
Director, Division on Agricultural Mechanization,  
The Japanese Society of Agricultural Machinery and Food Engineers.  
JAPAN  
hsgw@agr.niigata-u.ac.jp

## Introduction

We would like to express our deepest gratitude to Mr. KISHIDA Yoshisuke and his editorial staff for their efforts in carefully covering the topics of agricultural machinery development in various parts of the world since the first issue of the AMA in 1971, and for their efforts in building up a human network of researchers in various countries to celebrate the 50<sup>th</sup> anniversary of the journal.

Looking back over the 50 years of AMA's history in Japan from the viewpoint of mechanization of agriculture, the trends in the development of agricultural machinery in Japan include higher speed, larger size, improved comfort, improved operability to meet the needs of women, improved environmental friendliness, and increased intelligence. In this article, I would like to share the role of Japanese agricultural machinery-related industries in the next 50 years from the perspective of international cooperation.

## Development of Japanese Agricultural Machinery Industry through International Cooperation Agency

### Movements of Japan's International Cooperation Agency on Agricultural Machinery

When we think about Japan's agricultural machinery industry over the next 50 years, contributing to the resolution of issues in developing countries is a key word. The challenges faced by developing countries are diverse, including education, healthcare, urban development, infrastructure, the environment, and agriculture, and some of these challenges transcend national borders, such as climate change, infectious diseases, and terrorism, and it is expected that Japan, as a member of the international community, will contribute to solving these challenges. JICA is the world's leading international cooperation agency.

JICA's activities include technical cooperation for human resource development and institution building

in developing countries, investment and loans (yen loans) for large-scale infrastructure development such as airports, railways, and bridges, and the provision of technical assistance in the form of loans. There is a wide range of activities, including grant aid for basic infrastructure development such as schools, hospitals and water supply facilities, international emergency aid at the time of a disaster, and volunteer dispatch of Japan Overseas Cooperation Volunteers (JOCVs).

In recent years, I have had many opportunities to participate in JICA's technical cooperation and human resource development activities and online forums. In the field of agricultural and rural development, which is one of the challenges facing developing countries, we have heard many expectations from JICA for the Japanese agricultural machinery industry. In that sense, it is important for the Japanese agricultural machinery industry to consider collaboration with JICA. In particular, I believe that there are hints for this in the assistance to African countries that JICA is focusing on.



### **What Is the Benefit of Cooperation with International Agency in the Agricultural Machinery Industry?**

When I talk with Japanese agricultural machinery companies about overseas markets, I often hear that Japanese agricultural machinery has been developed mainly for paddy rice farming and that there is a lack of models that can be adapted to large-scale field crop management overseas. There are various stages of development in the early stages of mechanization, such as the development of pedestrian tractors and other agricultural machinery, as well as government-led tractors and work stations that provide various types of work equipment and maintenance services in some countries. Under these circumstances, Japanese agricultural machinery companies need to think in reverse to take advantage of the small size of agricultural machinery.

Recently, JICA has proposed a concept called Africa Field Innovation Center for Agricultural Technology (AFICAT). Under this concept, so-called smart farming solutions such as unmanned tractors, unmanned combine harvesters, drone cultivation management technology, and systems to automate water management in paddy fields have been demonstrated at the Tokyo International Conference on African Development (TICAD), and it has been attracting unprecedented attention to achieve the goal of increasing rice production tenfold in ten years in Africa.

In addition, JICA has been actively supporting the overseas expansion of private sector in recent years. The online forum hosted by JICA was considered to be an indication of JICA's proactive stance in promoting private-sector partnerships to achieve the goals of the SDGs.

### **Japan's Development Experience and Human Resource Development in the Agricultural Sector**

For Japanese agricultural ma-

chinery, to take root in Africa and to play a sustainable role, we need local human resources to support it. Japanese universities have an opportunity to train such human resources. It is called JICA Development Studies Program (JICA-DSP). The purpose of this program is to offer the opportunity to learn about Japan's modernization and development experiences, which differ from those of Europe and the U.S., and its wisdom as a country that provided cooperation toward the progress of developing countries after World War II.

For example, the ABE Initiative Program (Master's Degree and Internship Program of African Business Education Initiative for Youth) invites young people from Africa to Japan to obtain a master's degree at a Japanese university to foster African industrial human resources and "pilots" who will support Japanese private sectors in their business in Africa. The SDGs Global Leaders is a long-term training program for government officials from Asia, Oceania, Latin America, and Africa to study in Japanese graduate schools for doctoral and master's degree programs, and there are currently more than 100 trainees in the program. The course is designed to prepare trainees to become top leaders in policy making in order to help them to solve future policy problems in their countries. The course is designed to help trainees become top leaders who will be deeply involved in future policy decisions to solve the SDG policy issues faced by each country, and to build and strengthen networks with Japanese stakeholders (e.g., public agencies, private sectors, universities, NGOs, JICA, etc.) in various fields, which will result in the development of human resources who will know Japan well.

### **Advice for Japanese Agricultural Machinery Related Companies that Want to Expand Overseas**

When Japanese agricultural ma-

chinery companies intend to expand their business in Africa and other countries, they need to actively participate in the human resource development of foreign students studying in the above-mentioned degree programs in Japan, learn about the product needs of each country through the collaboration of foreign students and young employees, and form a multilayered network for building a service network. The human resources built by these joint efforts will be the ones who support the overseas expansion of the Japanese agricultural machinery industry. The human resources developed by these joint efforts will support the overseas expansion of Japan's agricultural machinery industry in the true sense of the word.

■ ■

# SDGs and Kubota's Vision



by  
Yuichi Kitao  
KUBOTA Corporation  
President and Representative Director.  
JAPAN

## Introduction

Allow me to offer my heartfelt congratulations on the 50<sup>th</sup> anniversary of AMA. Since publishing its first issue in 1971, the magazine has contributed to the advancement of agriculture in developing countries by reporting and providing suggestions about the mechanization of agriculture for the last 50 years. I have the utmost respect for the hard work of everyone involved in its publication.

Since the theme of this special issue is SDGs, the article we have contributed is about SDGs and Kubota's vision.

## Alignment of Kubota's Business and SDGs

This year marks the Kubota Group's 130-year anniversary. Spurred by our founder's desire to save people from cholera, Kubota succeeded in creating Japan's first domestically produced water pipes, and helped establish a modern water supply system. And to solve food shortage problems and eliminate hard labor in farming, in 1947 Kubota developed a domestically produced power tiller, helping to drive the mechanization of agriculture in Japan. Today we deliver ductile iron pipes to over 70 countries worldwide, and produce a total of over 30 million engines and 4 million tractors.

We view the United Nations SDGs

to be in alignment with the Kubota Group's goal of contributing to the international community in the areas of food, water, and the environment, under the slogan: "For Earth, For Life." Since our founding 130 years ago, Kubota has supported the lives of many in these areas. Our mission is to continue contributing to the international community as a "platform provider supporting life" by offering products and services that are in step with the times.

## Contributing to Achieving SDGs through Business

Kubota believes that comprehensive solutions are key to accelerating the attainment of SDGs through business. For example, while Kubota provides agricultural machinery to customers, we do not contribute to the overall food production system, so there is still much more we could do to contribute. In the future we hope to offer Food Productivity and Safety Solutions and facilitate the development of food production systems.

Another way we believe we can contribute to achieving SDGs is by offering Recycling-based Society Solutions. In the water and environment business, Kubota is carrying out R&D initiatives such as water purification and waste recycling, with the aim of building a resource-sustainable society in the future.

And we will focus efforts on en-

suring these total solutions are provided globally, not only in Japan.

## Food Productivity and Safety Solutions

We believe that the solutions to increase food productivity and safety we are considering will contribute to solving the global food shortage problem.

As the global population is projected to reach 9.7 billion in 2050, food security is a significant issue. Furthermore, CO<sub>2</sub> emissions related to the production, processing, transportation, and so forth of discarded food are said to account for around 8% of CO<sub>2</sub> emitted by humanity overall. With the aim of actualizing smart agriculture worldwide, Kubota will work towards achieving AI-based automated management by developing automated machinery and sensing and analysis systems that are linked to a wide range of data in order to expand crop yield, improve crop quality, and minimize food waste.

Kubota has already developed GPS-equipped models for all three types of agricultural machinery we offer: tractors, rice transplanters, and combine harvesters. We also provide a service called Kubota Smart Agri System (KSAS), a farm support system that links information such as work progress and operations such as cultivation management to machinery. In the future

we will work towards providing new solutions by incorporating full automation and AI technology in agricultural machinery.

## Recycling-based Society Solutions

The increase in the consumption of resources due to economic growth is also a global problem. We believe we can contribute to resource recovery with solutions to facilitate the actualization of a recycling-based society. For example, we are working on initiatives to make use of fertilizer components such as phosphorus recovered in the sewage treatment process in agriculture. Kubota is also focusing efforts on providing solutions to improve water-cycle efficiency and water quality.

Furthermore, we are researching initiatives to curb methane emissions, which are said to contribute to global warming. Research has shown that methane production can be reduced by extending the drying period for cultivated paddy fields. The Kubota Group is also proposing to change the method of agriculture to “wet direct seeding”, where seed rice coated with iron powder is sown directly in a flooded paddy field, or “dry direct seeding”, where seeds are sown in a dry field. These methods require less labor time than the conventional method of raising and planting seedlings, saving energy and labor. We will focus efforts on providing total solutions for this kind of agriculture primarily in Asia.

## No Growth Without Innovation

We believe that innovation is the key to providing total solutions for agriculture. Previously we mainly developed products for the next two or three years, but now we will need to develop products and create new services and businesses in anticipa-

tion of changes that will occur 10 or 20 years later. As a first step towards this, in 2019 we established Innovation Centers in Japan and Europe.

Quickly incorporating rapidly evolving advanced technologies such as ICT and AI is essential for providing new value, and a crucial part of this is open innovation with external partners such as startups, companies from other industries, universities, and research institutes. With our Innovation Centers taking the lead, we will work towards promoting open innovation and creating new value that exceeds our customers’ expectations by planning and proposing businesses, products, and services that span existing product categories, and investing in and jointly researching with our partners. We are also looking towards establishing Innovation Centers in other countries in the future.

## 10-year Long-term Vision

On January 2020, Kubota presented a concept tractor at a trade show (**Fig. 1**). Equipped with AI-based self-driving and fully electric technology, the tractor was born from the idea to enable a wide range of tasks to be carried out by a stand-alone unit, and represents Kubota’s vision for the future of farming. The face of agriculture is ever-evolving, and Kubota is evolving in response. We believe that it is important to continue developing products and services that meet the demands of the times.

Looking ahead to future changes in agriculture, we are currently for-

mulating our long-term vision for 2030, which will present Kubota’s growth strategy and vision for where we want the company to be. In today’s rapidly changing world, it is difficult to predict what will happen on a global level. But in order to make sustainable living something routine and ordinary, we believe that providing total solutions that integrate the areas of food, water, and the environment like those mentioned above will lead to maximizing Kubota’s contributions to society.

## Kubota's Values

I became president of Kubota on January 2020. Right after becoming president, the novel coronavirus pandemic put the global economy on hold. The pandemic impacted us in many ways, including forcing us to suspend operations of plants. However, because our businesses that underpin food production are essential businesses, it reaffirmed our responsibility to support people and society.

There are two phrases I tell Kubota Group employees to express Kubota’s values which I want them to prioritize in their work: “On Your Side” and “One Kubota”

“On Your Side” means that we are on the side of all our stakeholders, including agricultural workers; we identify changes they face beforehand, and solve issues that accompany those changes. “One Kubota” means that everyone in the Kubota Group works together as one team to provide total solutions.

We will strive to instill these values in our corporate culture and become a corporate group that is trusted by and continues to meet the needs of society. The areas of food, water, and the environment are essential for people to live. And we will contribute to the international community in these areas as we work towards our goal of achieving the SDGs. ■■

Fig. 1 Kubota concept tractor



# Agricultural Mechanization in the United States of America

by  
John K. Schueller  
Professor  
University of Florida  
Gainesville, FL 32611-6300  
U.S.A.  
schuejk@ufl.edu

## Abstract

United States agriculture is highly mechanized other than a few operations, such as harvesting some fruits and vegetables. Agronomic and forage crops are fully mechanized. The equipment varies widely, but is generally relatively large and sophisticated. About 80,000 new agricultural tractors of over 30 kW are sold annually, as well as many smaller tractors and much other agricultural equipment. Manufacturing and distribution of equipment are sufficient to meet the country's needs. Development and commercial adoption of precision agriculture, automation, and robotic technologies are proceeding.

## Agriculture in the United States

Agricultural mechanization proceeded rapidly in the 19<sup>th</sup> and 20<sup>th</sup> centuries in the United States of America building upon the innovations and efforts of people such as Cyrus McCormick, John Deere, J. I. Case, and Henry Ford and a conducive sociopolitical environment. Many firms produced a wide variety of agricultural equipment, including the products of over 200 tractor manufacturers early in the 20<sup>th</sup> cen-

tury. The public sector supported the development and adoption of agricultural equipment, such as by the institutions established by the Morrill Acts of 1862 and 1890, the Hatch Act of 1887, and the Smith-Lever Act of 1914 to enhance agricultural teaching, research, and extension respectively. The early and widespread adoption of agricultural mechanization in the United States is recognized as one of the most important achievements of the 20<sup>th</sup> century, releasing the vast majority of residents from agricultural labor to allow them to build a prosperous and powerful society (Schueller, 2000).

Agriculture in the United States is inherently very diverse due to the country's size of over 9 million square kilometers. The 2017 Census of Agriculture (USDA, 2019) provides data on agriculture and its mechanization. The census indicates that there are over 2 million farms covering over 150 million hectares of cropland plus vast pastures, rangelands, and other productive areas in a very wide range of climates. The machinery and equipment on these farms, therefore, also varies greatly. If a rough comparison must be made with many other countries, the machinery and equipment are generally comparatively large, modern, and sophisticated.

Plant agriculture and animal agriculture annually each produce about US\$ 200 billion of product. Soybeans, corn (maize), and wheat about equally have the largest cropping areas. Grains and oilseeds produce about half of the income farmers receive from plant agriculture. Fruit, vegetables, nuts, ornamentals, and other crops are often grouped together in a "specialty crops" category. Specialty crops are important economically, but do not occupy as large an area. The most valuable commodities in animal agriculture are cattle, poultry, dairy, and swine, in that order.

## Agricultural Machinery in the United States

According to the 2017 census, the value of all the machinery and equipment on the farms was about US\$ 272 billion. **Table 1** gives some information on some of the most common major equipment on the farms, including dividing into equipment manufactured in the five year period before the census and equipment manufactured prior. Tractors are subdivided into categories on the basis of power with the three categories being under 40 HP (30 kW), 40 to 99 HP (30-74 kW), and over 100 HP (74 kW). (Note that

the balers are almost all not self-propelled and that pickup trucks are frequently used for transportation and other nonagricultural work.)

The above agricultural census data is gathered from reports by farmers. It does not agree with the data reported by the agricultural equipment industry. **Table 2** gives sales information as reported in *Diesel Progress* (2020) magazine based on data from the Association of Equipment Manufacturers (AEM; www.aem.org), a group comprised of mainly equipment manufacturers. There are differences in the annual tractor sales rates, especially many more small tractors being sold in a single year than the census data implies. Besides misreporting, the differences may be due to many tractors being sold to municipalities, “hobby farms”, and other users who would not be surveyed by the agricultural census. The tractors in the AEM data were grouped into tractors with four equal-sized drive wheels (4WD) and those with larger wheels in the rear (2WD). It can be assumed that almost all the 4WD tractors are over

100 HP. The tractors are mainly from technology levels III to V on the Renius (2020) scale.

The inventory numbers in **Table 2** are for tractors that have been manufactured and yet are not sold on December 1, 2019. Many pieces of agricultural equipment are purchased from dealers’ inventories in the United States. The mostly-temperate northern hemisphere location of the country causes seasonality in sales. Between 25,000 and 30,000 total tractors and combines are sold each month during April and May while only slightly more than 10,000 are sold in November, January, and February. (Sales in December are higher for financial and tax purposes.) Changes in farm incomes, tax laws, and financial policies often cause deviations in equipment sales (e.g., Schueller, 2002). The COVID-19 pandemic will likely also have a significant effect. A great challenge for manufacturers and dealers is anticipating the demand for new equipment.

A 1919 Nebraska law required the testing of all models of agricul-

tural tractors sold in Nebraska (Hoy and Kocher, 2020). This led to the establishment of the Nebraska Tractor Test Laboratory (tractortestlab.unl.edu). Since tests are currently required for all tractors sold in Nebraska over 100 HP (74 kW) or which are to receive a Nebraska agricultural sales tax exemption, most models of tractors marketed for agriculture in the United States have test reports. These reports provide valuable information on the details and performances of the tractors. This allows farmers to compare models and encourages manufacturers to improve equipment performance.

The dominant fuel in tractors switched from gasoline to diesel over fifty years ago. Current tractors sold in the United States must meet the strict Tier 4 engine emissions standards from the U.S. Environmental Protection Agency (EPA). The contemporary emissions control systems generally require the additional farmer expense of consumable diesel exhaust fluid. Most of the tractors have power shift transmissions (with some having continuously variable transmissions), hydraulics, and PTOs. Although historically most tractors only powered the rear wheels, contemporary tractors now most often power both the rear wheels and the smaller front steering wheels. There also are tractors sold with unpowered front wheels, four equally-large powered wheels, two rubber tracks, and four rubber tracks.

Given the differences in rainfall, temperature, cropping systems, financial structures, etc., throughout the United States, it is difficult to generalize about agricultural mechanization in such a large and varied country. But there are some characteristics which are more common and will be discussed below.

The production of grains and soybeans (the dominant oilseed) are fully mechanized. Large equipment dominates, including self-propelled

**Table 1** Selected machinery and equipment on operations in 2017 (based on USDA, 2019)

Machinery or Equipment	Total	Manufactured 2013 to 2017	Manufactured Prior to 2013
Trucks, including pickups	3,343,533	546,400	2,797,133
Total Tractors	4,038,099	470,722	3,567,377
Less than 40 HP (30 kW)	995,918	98,566	897,352
40 to 99 HP (30 to 74 kW)	1,795,589	191,415	1,604,174
100 HP (75 kW) or more	1,246,592	180,741	1,065,851
Grain and bean combines, self-propelled	323,347	45,771	277,576
Cotton harvesters, self-propelled	18,217	3,068	15,151
Forage harvesters, self-propelled	64,081	8,191	56,890
Hay balers	662,339	75,303	587,036

**Table 2** Tractor and combine sales in the USA (*Diesel Progress*, 2020 from AEM data)

Machinery	2019	2018	Inventory
Total 2WD Tractors	241,748	233,452	138,894
Less than 40 HP (30 kW)	163,079	155,269	94,482
40 to 99 HP (30 to 74 kW)	60,086	60,231	35,708
100 HP (75 kW) or more	18,583	17,952	8,704
4WD Tractors	2,889	2,736	758
Total Tractors	244,637	236,188	139,652
Self-Propelled Combines	4,807	4,839	757

combine harvesters. Large tractors pull tillage and planting equipment. Considering the total land in the major crops of corn, soybeans, wheat, and cotton, about 20% of the crops are grown with no-till or strip-till practices and another 30% of the land alternates between conventional tillage and no-till or strip-till (Hellerstein, et al., 2019). Conventional moldboard plows or disk plows are much less popular than in other countries. Tillage and crop establishment is usually done by the farmer. Crop protection and crop harvesting may either be done by the farmer or a hired specialist. Large, often self-propelled, applicators apply fertilizers and plant protection chemicals.

Similar mechanization is present in other agronomic crops, such as cotton, sugar crops, and peanuts. The production of forages (hay, haylage, silage, and green-chop) is also mechanized. Due to the labor cost in handling small bales, the trend is towards large round or large rectangular hay bales to facilitate mechanized handling. Many bales are high-density to reduce transportation costs, but then machines are needed to make the forage accessible to the livestock.

The mechanization of specialty crops, such as fruits and vegetables, varies depending upon the commodity and its usage. Many specialty crops, for example some fruits and berries, have no accepted practical harvesting mechanization solution at this time. For other crops, especially vegetables such as potatoes, green beans, and sweet corn, practically all the crops are mechanically harvested. Specialty crops that will be processed, such as canned, frozen, or juiced, are much more likely to be mechanically harvested than those sold as fresh produce. Tillage, crop establishment (planting or transplanting), crop protection, and harvested crop transport are mechanized in most cases, although manual weeding may occur for or-

ganic production or where there is no adopted herbicide or mechanical solution. There is ongoing research and development into developing mechanization for the remaining manual operations.

There likely are now less than the 2009 estimate of 6,500 to 7,000 farm equipment dealerships in the United States (farm-equipment.com, 2009) due to the continued consolidation that has occurred. The remaining dealerships generally have sophisticated repair shops, as do many of the larger farmers. Tractor and combine sales to larger commercial farms tend to be dominated by the Deere, CNH, and AGCO multinationals. However, there are many different manufacturers and brands from domestic, foreign, and multinational companies, especially for implements, specialty crop equipment, and smaller tractors. A vibrant used equipment market, including much now online, allows smaller or financially-limited farmers to access equipment that no longer serves the needs of its original purchasers. A typical conditions and niche markets are generally well-served by an economic and sociopolitical environment which facilitates local equipment innovation and allows equipment importation.

Although domestic and multinational manufacturing plants are scattered throughout the country, there is a concentration in the “corn belt” for tractors and general equipment. The long history of agricultural machinery manufacturing in the United States has allowed the manufacturing techniques and organization to become optimized (e.g.,

Reid, et al., 2003.) The United States is both major exporter and major importer of tractors and other agricultural machinery. The equipment exported tends to be relatively large and sophisticated. For example, many large tractors are exported to Canada and Australia. More units of equipment are imported, but they tend to be smaller and more basic in technology unless they are for specialty crops or niche markets.

## Precision Agriculture

Precision agriculture has been studied and adopted in the United States for many years (e.g., Searcy, et al., 1989; Schueller, 1992). Hellerstein, et al., (2019) and Schimmelpfenning (2016) include graphs of the adoption of some of these technologies for some common agronomic crops. **Table 3** shows measurements made from those graphs for the most recent surveys of the crops. The data reports the percentage of crop planted acres that utilized the corresponding technology. Yield mapping during harvesting allows the producer to understand the spatial variability of the production and provides inputs for potential strategic or tactical adjustments to improve profitability. The Global Positioning System (GPS) for tractors, fertilizer and chemical applicators, and harvesters has allowed automated guidance systems to become very popular in the United States. Anecdotal evidence implies that automated guidance adoption has continued to increase from the data in **Table 3**. Variable rate tech-

**Table 3** Precision agricultural adoption (based upon graphs in Hellerstein, et al., 2019)

	Year	Yield Mapping	Automated Guidance	Variable-Rate Technologies
Corn	2016	41	66	45
Cotton	2015	16	32	7
Peanuts	2013	18	49	6
Rice	2013	21	54	18
Soybeans	2012	22	45	30
Spring Wheat	2009	14	56	13

nologies, such as for applying fertilizers and pesticides according to localized spatially-variable needs, are gradually being adopted. Different development (e.g., Whitney, et al., 1999) and adoption rates of related technologies are also occurring in specialty crops. In some cases, there are barriers to adoptions of digital technologies, such as lack of hardware and software training, privacy and security concerns, insufficient data management platforms, and uncertainty of how to derive value from acquired data (Drewry, et al., 2019).

## Agricultural Mechanization Trends in the United States

The current political and coronavirus affects on farm labor availability are focusing more attention on increasing mechanization for those crop operations that are still manual. For example, the cost of manual harvesting is sometimes over half the cost of producing a fruit or vegetable. There is ongoing work in developing both mass harvesters that will simultaneously remove multiple fruit with shaking or combing actions and robotic harvesters that will pick individual fruit.

The widespread broadcast spraying of pesticides increases production costs and has environmental impacts. Hence, there is a concerted effort to use mechanization or innovative chemical methods to reduce or eliminate pesticide applications.

**Fig. 1** Unmanned tractor pulling a citrus tree sprayer



Some systems will only apply the pesticide where the pest is present. Other systems use mechanical means to eliminate the pest. These systems are not widespread yet, but their use may increase.

Unmanned vehicles are a current mechanization trend. Small, unmanned aerial vehicles (UAVs or drones) are used for scouting and some limited application purposes. There has also been research and development work on unmanned ground vehicles. For example **Fig. 1** shows an unmanned tractor pulling a sprayer in a citrus grove. Although many tractors in the United States have automated guidance to follow a straight path in fields, they are still manned.

The increased emphasis on electronic and computer technologies has been challenging for the employees of the manufacturers, dealers, and users who do not have familiarity with those technologies. But it is expected that there will continue to be increases in the use of sensors, precision agriculture, and computer networking. It is likely that the agricultural machinery will increasingly be an integrated part of automatic data gathering and control to maximize farm profitability.

The integration of electronics, automation, and data into agricultural machinery has raised a large number of ownership and legal issues that need to be resolved. It is uncertain of who will have the responsibility and liability when something bad happens, such as a death or major property damage. In addition, there are legal and political battles over the “right to repair” (e.g., Solon, 2017). Whether users and unauthorized repairers should have access to software code, repair tools, and hardware is controversial. Equipment manufacturers argue safety, security, and intellectual property concerns override the historical precedent of users repairing the equipment themselves or

using unaffiliated repair personnel to achieve affordable and timely repairs.

## Acknowledgements

Thank you to Professors Tim Stombaugh of the University of Kentucky and Brian Luck of the University of Wisconsin-Madison for reviewing parts of this manuscript.

## REFERENCES:

- Diesel Progress. 2020. Positive U.S. Ag Tractor Growth in 2019. Diesel Progress 86(2): 56. February.
- Drewry, J. L., Shutske, J. M., Trecher, D., Luck, B. D. and Pitman, L. 2019. Assessment of digital technology adoption and access barriers among crop, dairy, and livestock producers in Wisconsin. Computers and Electronics in Agriculture. 165: 104960.
- farmequipment.com. 2009. The Biggest Farm Equipment Dealers in North America. www.farmequipment.com posted 17 July 2009, accessed 15 June 2020.
- Hellerstein, Daniel, Dennis Vilorio and Marc Ribaud, eds. 2019. Agricultural Resources and Environmental Indicators, 2019. EIB-208. U.S. Department of Agriculture. Economic Research Service. May.
- Hoy, Roger M. and Kocher, Michael F. 2020. The Nebraska Tractor Test Laboratory: 100 Years of Service. ASABE Distinguished Lecture No. 41. Agricultural Equipment Technology Conference. 10-12 February. Louisville, Kentucky.
- Reid, J. F., Schueller, J. K. and Norris, W. R. 2003. Reducing the manufacturing and management costs of tractors and agricultural equipment. Agricultural Engineering International. Vol. V. <https://cigrjournal.org/index.php/Ejournal>
- (Continued on page54)*

# Fifty Years of Progress in Agricultural Mechanization



by  
 Brian Sims  
 FAO Agricultural Mechanization Consultant.  
 3 Bourneside Bedford MK41 7EG  
 U.K.  
 sims.brian2@gmail.com

Josef Kienzle  
 Agricultural Engineer  
 FAO, Leader: Sustainable Agricultural Mechanization  
 task team Plant Production and Protection Division (NSP)  
 GERMANY  
 josef.kienzle@fao.org

So much has happened over the past 50 years in the world of appropriate mechanization for small-holder farmers – the target group for AMA. In the past we have seen tractor and machinery hire services, often subsidized, run by public sector agencies. These have rarely been successful (FAO, 2008, p21) mainly due to inefficiencies (eg.: a high percentage of travel time, small and scattered plots, difficulties in receiving payments for services rendered, high levels of down time due to problems of servicing and accessing replacement parts and inappropriate civil service bureaucratic management systems – **Fig. 1**).

Traditionally there has been an over-reliance on the plough to bury weeds, break up bare, hardened soils at the end of the dry season and treat compacted horizons. We now recognize the environmental damage wreaked on natural resources through the destructive application of plough-based soil preparation practices. Soils were compacted, plough pans formed, water infiltration was impeded and surface runoff increased as a consequence. Mechanization was acquiring a poor reputation for damaging agricultural soils and degrading natural resources and so was simply not sustainable. One solution, called sustainable agricultural mechanization (SAM) by the FAO, seeks to improve the supply of essential power and mechanization to small-

holder farmers while at the same time conserving natural resources, particularly soil and water.

FAO's SAM website (FAO, nd) describes the SAM concept as follows:

*Mechanization covers all levels of farming and processing technologies, from simple and basic hand tools to more sophisticated and motorized equipment. It eases and reduces hard labour, relieves labour shortages, improves productivity and timeliness of agricultural operations, improves the efficient use of resources, enhances market access and contributes to mitigating climate related hazards. Sustainable mechanization considers technological, economic, social, environmental and cultural aspects when contributing to the sustainable development of the food and agricultural sector.*

**Fig. 1** Tractors in public sector hire schemes frequently suffer from poor maintenance and a lack of replacement parts. (Photo: Brian Sims)



At its heart SAM adopts the principles of conservation agriculture (CA) as a means of environmentally-friendly crop production. The principles are embraced by FAO's Save & Grow paradigm which encourages and promotes practices aimed at producing more and better with fewer potentially damaging inputs (FAO, 2001). As a reminder, CA is based on three vital pillars which are:

- Disturbing the soil as little as possible. This means establishing the crop with direct seeders – no-till drilling and planting – and not cultivating the soil either for seed-bed production or weed management.
- Keeping the soil surface covered with organic matter. Crop residues are not removed, incorporated or burnt but, as far as possible, are left on the soil surface to protect it against erosion and to conserve

**Fig. 2** Animal-drawn direct planter (Knapik, Brazil) with double offset inclined discs to cut through surface vegetation and deposit seed and fertilizer at the required depths in the soil profile. (Photo: Brian Sims)





soil moisture. Cover crops are used to extend soil cover into the post-harvest period.

- Increasing the number of species grown as crops, cover crops and associated crops to maximize biodiversity on the farm. This will include the inclusion of agroforestry practices.

At the centre of CA mechanization is the direct seeder or planter. A wide range of equipment is available from low-cost animal-drawn machines using discs and/or narrow chisel tines to open a slot in the soil and allow the seed to be sown at the required depth **Figs. 2 and 3**).

Weed and cover crop management is achieved by mechanical means (for example with knife rollers (**Fig. 4**) or rotating knife machines such as a weed header) or with the judicious use of herbicides when non-chemical means are not sufficient. Biological weed management is always the preferred option through cover crops and associated crops (Sims, et al., 2018).

When using combine harvesters to harvest CA cereal crops, the crop residues are spread evenly over the field surface, rather than being deposited in a windrow, as part of the regime of maintaining soil cover. Straw spreaders are needed at the rear of the machine to ensure even residue distribution over the entire width of cut. For more detailed information, a recent book chapter discusses the mechanization solu-

tions for CA for a range of conditions around the world (de Araujo, et al., 2020).

We now have a situation where we know how to better manage our natural resources in parallel with an increase in agricultural production and in line with mitigation of the impacts of the climate crisis, but at the same time we have a situation where smallholder farmers with limited financial resources often have difficulty in accessing the necessary mechanization technology. One way to overcome this obstacle is to support a cadre of mechanization service providers who can offer the required CA mechanization service to a number of farmers and so keep the costs of the work to a reasonable and, importantly, affordable, level.

An examination of the situation has revealed that budding service providers may need help in both technical and business management skills. The advantage of having service providers well versed in the correct adjustment and operation of their machinery is clear, as the farmers should receive a proficient and technically excellent service. And of course, a good service provider will be able to attract a larger clientele and so be able to reduce costs by spreading them over a greater number of farmers.

Technical skills needed include machinery selection (eg: for output, work rate and manoeuvrability);

machinery maintenance; calibration (especially of seeders and sprayers – **Fig. 5**); and operation.

Running a successful service provision enterprise will require skills in market evaluation; cost calculation to arrive a break-even points, profit margins and charge rates; assessing service back-up and finance opportunities. FAO has recognized the needs of emerging service providers and has seen the need for training in the skills outlined above. The needs are addressed in a training manual (FAO, 2018), fully field-tested and aimed directly at trainers for capacity building in providers of sustainable mechanization services to progressive farmers. This will allow farmers to ‘save & grow’ and produce more and better products while ensuring that essential natural resources are there for future generations.

Recently, a new example of agricultural machinery leasing contracts has emerged for mechanization service providers (Ag Lease Co, 2019). This Zambian initiative may prove to be the previously missing piece in the puzzle to give the provision of sustainable mechanization services for smallholder farmers the break through that it needed. Specialized financial service providers such as Ag Lease Co provide the financial resources for start-up mechanization service providers to access the required machinery under stable leasing arrangements. Targeted in-

**Fig. 3** Tractor-mounted direct planter (Vence Tudo, Brazil). A suitable implement for entrepreneurs to supply CA service to smallholder farmers. (Photo: Brian Sims)



**Fig. 4** An animal drawn knife roller for the management of weeds and cover crops. Blades on the roller crimp the plants to desiccate them. (Photo: Brian Sims)



**Fig. 5** Calibration of a two-wheel tractor mounted direct planter (Fitarelli, Brazil). (Photo: Brian Sims)



centives can favour the application of climate smart practices (compatible with CA principles); while traditional ploughing is punished.

Another innovation is the development of the use of information and communications technology (ICT) for mechanization services on call. Often it is simply the accessibility or reachability of services providers that is the obstacle for smallholders needing mechanization services. New start-up companies such as TroTro Tractor Ltd in Ghana (TroTro Tractor Ltd, nd) or Hello Tractor in Nigeria (Hello tractor, nd) have proven that ICT and simple mobile phone technology (short message service – SMS-based) can close this gap successfully.

As we have learnt, AMA has seen great changes in its 50-year history and so we wish the publication a Happy Golden Anniversary and hope to see many more years to come!

## REFERENCES

- Ag Lease Co, 2019. Ag Lease Co: mechanising Zambian farms [https://www.slideshare.net/ACTIIIage/jonathan-g-ag-leaseco-mechanizing-zambian-farms-206683681. Accessed 27 March 2020.]
- De Araujo, A. G., Sims, B., Desboilles, J., et al. 2020. Advances in conservation agriculture. Volume 1: systems and science. Chapter: The status of mechanization in CA systems. 2020. Burleigh Dodds, Cambridge, UK. pp69. [https://drive.google.com/file/d/12V1Vqo3I90Om\_NWq7n8W-gHPgviCtNYnI/view. Accessed 9 March 2020.]
- FAO, 2001. Save and Grow: a policymaker's guide to the sustainable intensification of smallholder crop production. Food and Agriculture Organization of the United Nations. Rome, Italy. pp102. [http://www.fao.org/ag/save-and-grow/. Accessed 9 March 2020.]
- FAO, 2008. Agricultural mechanization in sub-Saharan Africa: time for a new look. Mrema, G., Baker, D. & Kahan, D. Food and Agriculture Organization of the United Nations, Agricultural, Marketing and Finance Occasional paper. Rome, Italy. pp54. [https://www.researchgate.net/profile/David\_Kahan4/publication/269760217\_Agricultural\_Mechanization\_in\_Sub-Saharan\_Africa/links/549546680cf2ec1337587103.pdf. Accessed 9 March 2020.]
- FAO, 2018. Hire services as a business enterprise. A training manual for small-scale mechanization service providers. 2018. Food and Agriculture Organization of the United Nations (FAO), International Maize and Wheat Improvement Center (CIMMYT), Rome, Italy. Brian Sims, David Kahan, Joseph Mpagalile, Martin Hilmi, Santiago Santos Valle. pp127. [http://www.fao.org/3/I9207EN/i9207en.pdf. Accessed 9 March 2020.]
- FAO, nd. [http://www.fao.org/sustainable-agricultural-mechanization/en/. Accessed 27 March 2020.]
- Hello Tractor, nd. [https://www.hellotractor.com/home. Accessed 27 March 2020.]
- Sims, B., Corsi, S., Gbehounou, G., Kienzle, J., Taguchi, M., Friedrich, T. 2018 Sustainable weed management for conservation agriculture: options for smallholder farmers. Agriculture 2018, 8(8): 118 (20 pp) [https://doi.org/10.3390/agriculture8080118. Accessed 6 March 2020.]
- TroTro Tractor Ltd, nd. [https://www.trotrotractor.com/. Accessed 27 March 2020.]

■ ■

# 50 Years of AMA, the SDGs and Agriculture in Germany



by  
Karl Th. Renius  
Retired Director of Institute of  
Agricultural Machinery,  
TU Munich, D-85748 Garching  
GERMANY  
renius@ftm.mw.tum.de

## 50 Years of AMA – a Success Story

First of all, my sincere congratulation from Germany on 50 successful years of AMA – from myself as a regular reader and expressly supported by Prof. Dr.-Ing. Peter Pickel, the current President of our German Max-Eyth-Society for Agricultural Engineering (VDI-MEG). We know AMA as a unique international journal supporting in particular worldwide improvements of agricultural mechanization in less developed countries.

Founding the *Club of Bologna* in 1988, its first President Prof. Giuseppe Pellizzi used his close links to Mr. Kishida, Chief Editor and drive wheel of AMA, to nominate important persons from the AMA list of co-operating editors as *Club of Bologna* members supporting the initial Club development considerably.

Working for a future sustainable world, agricultural engineers demonstrate that co-operation and friendship can cross almost all political and social borders, working on goals such as the 17 SDGs of the United Nations, as follows.

## The 17 Sustainable Development Goals (SDGs) of the United Nations

Declared in 2016 and supported by 139 nations, the SDGs define improved and sustainably organized living conditions worldwide for the year 2030.

The author of this article would like to select and to rank the following seven SDGs as particularly important from his point of view as an agricultural engineer:

1. *Ended poverty* (SDG 1)
2. *Peace, legal certainty and human rights* as a general standard (SDG 16)
3. Effective system of *administration and institutions* at all levels (SDG 16)
4. Updated *education systems* (SDG 4), access for all population levels
5. Sustainable *agricultural mechanization* and general *industrialization* (SDG 9)
6. Developed *infrastructure* (SDG 9), in particular for *drinking water* and *sanitation* (SDG 6), *health systems* (SDG 3), *clean energy* (SDG 7) and *transport systems*
7. Sustainable *consumption patterns* (SDG 12)

*Ended poverty can usually not be commanded sustainably by an isolated process. It is much more a common result of realizing all the other listed goals – beginning with peace, legal certainty and human rights.*

For developing industrialization (SDG 9), agricultural mechanization is usually the initial condition reducing the number of working people in agriculture enabling a transfer of manpower to other areas of the national economy working on the listed goals. It was shown by several publications of the *Club of Bologna* that there is a clear *correlation between the level of agricultural mechanization and the level of general prosperity* [8, 9] including responsibility for adequate sustainability [3].

## EU Focusing on Reduced Greenhouse Gas Emissions

In 2013, the EU “Green Paper” required a reduction of green house gas emissions by at least 40% during the period of 1990-2030. Energy efficiency of agricultural machinery was already considerably improved until now, even in spite of strong reductions of exhaust gas emissions

other than CO<sub>2</sub> what complicated an improved fuel economy. A new test was developed in Germany for tractor-implement systems: The “DLG-PowerMix” simulates practical loads and speeds in addition to the OECD code [10]. This initiated a strong competition between tractor manufacturers with continuously reduced specific fuel consumptions driving implements and pulling trailers. The current “world record” is held by a Fendt 1050 Vario: Only 233 g per summarized kWh net output (including all energy losses) for a typical mix of operations.

Agricultural machinery contributes with 0.75% to the German CO<sub>2</sub> emissions [4]. Striving for further reductions, the related industry initiated the research project *EKoTech – Efficient fuel use in agricultural technology*. It was funded by the German Ministry of Agriculture (2016-2019) and carried out in a cooperation of leading companies and research institutions [6, 2]. Respecting the already high machinery efficiencies, *EKoTech* concentrated on machinery production chains.

Substantial potential of savings was, for example, found by combining processes.

## Agricultural Structure and Production in Germany

Statistics on the German agriculture are published in [4, 5], figures on EU in [11]. 51% of the surface of Germany is used for agriculture (16.7 mill. ha), among which 70.6% is arable land. 28.2% is permanent grassland and 1.2% permanent crops (forests excluded). Wheat is the main cereal (3.1 mill. ha) with an average yield of 8 tons per hectare (2018). Corn is also important, mainly as green silage feeding cattle and biogas power plants. Other important crops are rape seed, potatoes and sugar beets. Rice, cotton and sugar cane are not produced in Germany but there are first steps of

growing soybeans due to the climate change.

About 10% of the total farmland was used for organic production in 2019 – with a slightly increasing trend, supported by the government. Milk production per cow is about 8000 kg per year as an average (2019). A certain over production results in very low prices, 0.337 € (0.37 US\$) per kg in 2019 as an average; however, 35-40% higher for organic milk with increasing market shares and profits. The average German dairy farm has 67 cows (2019), still slightly increasing.

The total number of farms (> 5 ha) has decreased over the decades to about 266.000 in 2019 along with increased farms sizes, and as much as 58.5% rented farmland. The average size in Germany is about 65 ha (2019) – lower in the western regions, higher in the eastern part. About half of all are part-time farms. Turn over of the German Agriculture (including forestry and fisheries) was 53.2 bill. € (58.5 bill. US \$) in 2018 (12.2% of EU). Direct EU subsidies were 4.8 bill. € (5.3 bill. US \$) in 2018.

The German agriculture is highly mechanized. Average capital investment for one employee is about 600,000 € (660,000 US \$), mainly for machinery. Only 1.4% of the working population is still engaged in agriculture contributing about 1%

to the gross value added. Contracting and co-operating are important economic factors.

## Digital Agriculture Versus Industry 4.0

Industry 4.0 addresses digitalization and automation of production systems within the entire German industry. The term was created in 2011. Large research programs and investments supported meanwhile an accelerated broad digitalization.

*Modern German agriculture can be seen as a certain forerunner of Industry 4.0* with first important steps more than 30 years ago [1, 10]. Automation of agricultural machinery with digital networking via ISOBUS and GPS is reality. Productivity, sustainability, health, safety and comfort have been improved. Replacing open loop controls by closed loop controls [10] required high investments for new components such as electronically controlled diesel engines, continuously variable automatic transmissions (CVTs), electro-hydraulics, drive by wire steering systems, new 4WD systems, improved auxiliary components, continuously variable electric motors etc.

**Fig. 1** demonstrates some figures about the practical acceptance of digitalization and automation, based

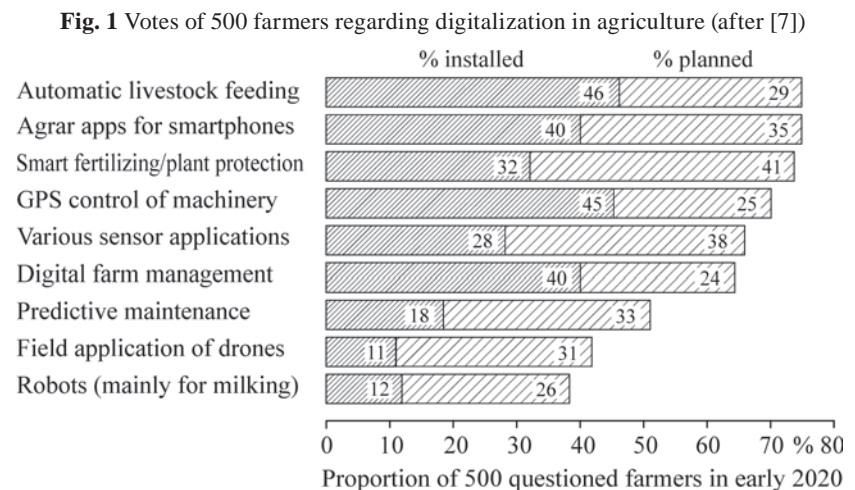

on a questionnaire among 500 farmers [7].

In addition, very high investments have been applied for diesel engines to meet the step-by-step tightened EU regulations on exhaust emissions: NO<sub>x</sub> and particles were reduced by *more than 95%* by EU stages I-IV within the period 1999-2014.

### Typical Remaining Problems of German Farmers

Farmers suffer under some EU regulations, regarding reduced fertilizing, restricted slurry handling, reduced chemicals for plant protection, restrictions for field use and tightened conditions of live stock farming. Revenues of their products are low as based on world market levels. Introduced strict EU health and safety regulations have been often not popular with their (forced) introduction but are gradually accepted as they reduced accidents, violations and the number of killed farmers considerably [10]. Future research and co-operation can help to look for reasonable goals of EU politics and governmental acts.

### German Agricultural Machinery Industry

According to statistics of the German Machinery Industry Association (VDMA), turnover of the German industry for tractors and all other agricultural machinery was about 8.5 bill. EURO (9.4 bill. US \$) in 2019 with about 4 bill. EURO (4.1 bill. US \$) for tractors (excluding CLAAS tractors, which are produced in France). Export rate is very high, was 76% in 2019.

Germany is No. 1 in sales on the world market since many years, leading in technology for tractors and many other kinds of machinery. The secret is the flexible structure of small and medium sized enterprises

(SMEs), most of them private, and other larger family owned companies: Reacting fast on new market demands, have close co-operations with research institutions, employ high-level skilled workers and well-educated agricultural engineers not only from agricultural faculties but also from mechanical engineering faculties. Covid-19 will reduce the turnover of the German industry in 2020 but there is a high motivation to limit the losses by flexibility, new ideas, accelerated digitalization and political support.

### REFERENCES

- [1] Auernhammer, H. and Schueller, J. K. 1999. Precision Farming. In: CIGR Handbook of Agricultural Engineering Vol. III, Plant production engineering: 598–616. St. Joseph Mi, USA: American Society of Agricultural Engineers.
- [2] Frerichs, L. et al. 2017. EKOtech - A Holistic Approach to Reduce CO<sub>2</sub> Emissions of Agricultural Machinery in Process Chains. SAE Technical Paper 2017-01-1929.
- [3] Gavioli, G. 2019. Importance of sustainability assessment and circular economy in agricultural machinery production. Club of Bologna, 29th meeting Hannover, Nov. 15-16, 2019. <http://www.clubofbologna.org>.
- [4] German Farmer Association. 2019: Bericht des Deutschen Bauernverbandes DBV (Report of the German Farmer Association), Berlin: Dec. 2019.
- [5] German Ministry for Food and Agriculture. 2019. Agrarpolitischer Bericht der Bundesregierung 2019 (Report of the German Federal Government on agricultural structure and politics 2019). Berlin: BMEL.
- [6] Götz, C. and Köber-Fleck, B. 2019. More output, less CO<sub>2</sub> – Saving Fuel with Innovative Agricultural Machinery. Booklet of VDMA, Section Agricultural Machinery. Frankfurt/Main, Germany.
- [7] N. N. 2020. Landwirtschaft wird digitaler (Agriculture more digital). *top agrar* 49 (6): 14.
- [8] Pellizi, G. and Fiala, M. (Editors) 1992. Agriculture, Mechanisation and Manufacturing Facilities in 30 Countries (1970-88), also called “Country Reports.” Club of Bologna, 4<sup>th</sup> meeting Bologna, Nov. 4-5, 1992.
- [9] Renius, K. Th. 2015. Agricultural mechanization – a key for future mankind welfare. Open Meeting of the Club of Bologna, EXPO Mailand, Sept. 21, 2015. <http://www.clubofbologna.org>.
- [10] Renius, K. Th. 2019. Fundamentals of Tractor Design. Cham: Springer.
- [11] Schulze-Lammers et al. 2016. Agricultural mechanization in Europe. In: L. Bodria and Fiala, M. (Editors): The 25 Years of the Club of Bologna: 52-84. Rome: FederUnacom. <http://www.clubofbologna.org>.

■ ■

# Development Trend "Digital Agriculture" from a German Perspective



by  
Peter Pickel  
Prof. Dr.  
John Deere GmbH & Co. KG European Technology  
Innovation Center, Kaiserslautern  
Chairman of the German Max-Eyth-Society for  
Agricultural Engineering (VDI-MEG)  
GERMAN

Congratulations to AMA for 50 years of success! All the best for the future of this exciting journal describing, analyzing, and supporting worldwide improvements of agricultural mechanization in developing countries. This article will give a view on a major trend in an highly industrialized country!

## General Conditions

Europe, or more precisely the European Union, has been in a permanent crisis over the last 10 years. Specific fields of problems have been the financial crisis, the refugee crisis and the Brexit. This year, the Covid-19 pandemic was added to these. In view of these “problem mountains”, the EU has long only been able to react rather than act. The new Commission President, Ursula von der Leyen, is trying to change this and is taking the reins of action. With the Green Deal, she wants to make the EU a global role model or pioneer in climate protection and general sustainability. The political and social discussions show that agriculture has a special role to play in sustainability. The issue of sustainability will influence the work of agricultural engineers over the entire next decade.

Based on the Kyoto Protocol of

1997 and the Paris Agreement of 2015, the German government has created a coherent legal system in the years 2016 to 2019, which obliges Germany to reduce its annual CO<sub>2</sub> equivalent emissions by 55% by 2030 compared to 1990 and to strive for CO<sub>2</sub> neutrality in 2050. For agriculture, this means that annual CO<sub>2</sub> emissions must be reduced by 17% between 2017 and 2030. On the one hand, Germany is relying on regulatory measures and, on the other hand, CO<sub>2</sub> pricing will be introduced starting from 2021, what shall promote the market for CO<sub>2</sub>-reducing technologies. It is to be expected that national climate protection plans and laws will have to be revised (i.e. tightened up) again in the course of the European Union’s Green Deal activities.

However, the sustainability debate is not only about greenhouse gas emissions. Other aspects are the preservation of natural biodiversity, the management of permanent structural change in rural areas, the safety and quality of food, its traceability or the transparency of food production and the guarantee of a fair income for farmers.

Some years ago, the European agricultural machinery manufacturers, through their umbrella organisation CEMA, committed themselves to a guiding principle or a guiding task

[1]: “Producing more with less”! In other words: Increasing yields and farmers’ incomes with less input. To follow this principle is an imperative of our time from an economic, ecological and social perspective. CEMA “draws” a four-pillar model for increasing the climate friendliness of future agricultural technology. The four pillars are:

1. increase in machine efficiency
2. improving agricultural processes and process management
3. optimizing the behavior of machine users
4. use of renewable energy

A particularly high impact is attributed to the second pillar – improved agricultural processes and process management. Especially precision farming and highly automated machine systems are carrier of hope in this second pillar. Such highly automated systems are often also described with terms such as Smart Farming Systems or Agriculture 4.0.

## Definition of Digital Transformation in the Agricultural Sector

Our time is shaped by fashion, with keywords or “buzzwords” to throw around. Popular buzzwords include Industry 4.0, Internet of

Things, Internet of Services, Big Data, Cyber-physical Systems, Smart Farming, Digital Transformation and of course Agriculture 4.0, which is of course a variation of Industry 4.0.

The above mentioned keywords essentially shape the response of agricultural engineers to the challenges of achieving the Sustainability Development Goals (SDGs). In fact, progress is taking place on several levels and areas – amongst these technology progresses are gained:

1. through incremental improvements
2. by introducing precision farming technologies
3. through comprehensive introduction of Agriculture 4.0

The first point is a permanent task for engineers! But what exactly is Precision Farming (PF)? PF can best be defined as a vision: The vision of Precision Farming is to use the most precise control and regulation technologies to supply each plant individually with water, nutrients and plant protection measures in the best possible way, i.e. with optimal (or minimal) inputs but so that the yield reaches an economic optimum.

We approach this high level of precision of the actuators in two ways:

First, through high-precision positioning technology (“controlled positioning”) (Fig. 1). In this way,

we can already perform sowing so precisely in some crops that we know exactly where the location of which (individual) plant is. In weed control, this means we know where the weeds are (exactly where there is no crop) and can control them mechanically or chemically.

The second path is the increased development and use of sensor-guided methods, today increasingly with imaging techniques and image analysis based on AI methods. Learning systems observe and analyze the plant stand. Targeted measures can be taken against herbs and in the future certainly also against infestation by harmful organisms.

Sensors can be carried on the agricultural machines or implements but also on drones or anywhere in the agricultural production environment. Even satellites deliver information (e.g. on biomass development). Another example for precise actuation based on sensing technology are applications of Near Infrared Spectrometry (NIRS). First applications were biomass detection in fertilizer operations. Today, NIRS is coming up for constituent sensing. For example, protein content measurement is already possible in grassland harvest and the same technology can be used for determination for nitrogen content in slurry operation. The latter allows for precise dosing of Nitrogen even though slurry can

be extremely heterogenous. The N-dosing in driving direction can be done by pump control. An alternative way is to put pump on constant (maximum) output and command the driving speed from the slurry trailer the guiding tractor via ISOBUS class 3 mode (also known as “TIM”: Tractor-Implement-Management).

Both paths (controlled positioning and sensor or image based analysis) certainly have their justification and will probably continue to establish themselves alongside each other.

Finally, the question arises: What is Agriculture 4.0? Well, this fashionable term is of course based on the keyword “Industry 4.0” – also a buzzword!

Professor Liggesmeyer from the German Fraunhofer-Institute for Experimental Software Design defined it this way in 2017 in an interview in a Fraunhofer-blog [2]:

*“The fourth industrial revolution is characterized by the replacement of mass products by mass-individualized products. Companies will be able to manufacture products tailored to individual customer needs in small batches at low cost. This means with a similar cost structure as in mass production. Those who want to manufacture individually in the future will need production facilities with certain capabilities that are only available in parts today. Aspects such as digitalization, networking, autonomy and openness of the systems serve to realize these capabilities.”*

In agriculture, the situation is somewhat different compared to manufacturing. Here it is not a question of customer-individualized products, because the primary production of food is usually very far away from the end customer in the value-added chain, so that customer individualization is usually not important. I would therefore like to define “Agrartechnik 4.0” as follows, based on Prof. Liggesmeyer:

*The agricultural or agro-technological revolution 4.0 is character-*

**Fig. 1** Highly automated, high precision single corn seed for maize and sugar beet corresponds autonomy level 3 acc. SAE J3016 and allows for accuracy down to +/- 1cm



ized by the replacement of mass production by (mass-)individualized production. Agricultural enterprises are enabled to establish processes tailored to the needs of the individual product (i.e. in the arable farming of plants as individuals) at low cost, i.e. with an improved cost structure. Anyone who wants to carry out such individualized agriculture in the future, focusing on the product, will need machines, equipment and plants with certain capabilities that are only partially available today. Aspects such as digitalization, networking, autonomy and openness of the systems will be used to realize these capabilities.

This is the vision of Agriculture 4.0! And: Precision Farming is part of this Agriculture 4.0!

Core elements of Agriculture 4.0

In fact, hardly any other sector is as far advanced in implementing the methodological approaches of Industry 4.0 as agriculture or agricultural engineering. On the one hand, this applies to stationary technical (mostly indoor) facilities such as in animal husbandry - here the use of robots and networking is used more than in any other economic sector; on the other hand, this also increasingly applies to outdoor production (arable farming, horticulture, and grassland) with its mobile machines, which in terms of automation technology will become completely vertically integrated, and the entire process will be controlled in “the cloud”. Production process control will be horizontally networked with upstream and downstream sub-processes on the farm and along the entire value chain of food production from seed producers to retailers and thus to the end consumer, whereby all sub-processes can be managed or supported by external information and consulting services.

Six core elements are characteristic of Agriculture 4.0:

1. the Farm Management Information Systems (FMIS), which are already widely available today,

will further develop into Farm Management Systems (FMS). In other words, “Decision Support” systems will make decisions on production processes as far as possible autonomously or independently from direct human control. Agricultural processes will no longer be controlled individually, but as an integrated production system similar to an Industry 4.0 production facility (Fig. 2). The FMS can also be described abstractly as process control levels.

2. All production processes and details are comprehensively documented, and the collected information becomes part of a networked or meshed (food) production. One could call this “meshed production”. The upstream and downstream sectors will of course be involved in the information chains in the same way as primary agricultural production.
3. suppliers of agricultural inputs (chemicals, seeds, etc.) might change their products or services. Take crop protection as an example: more results or successes will probably be sold instead of spray agents. This may include success insurances or similar services.
4. 5G communication standards, which will soon emerge step by step, will allow high bandwidth and/or low latency communication

in cellular sub-networks. This will enable highly dynamic control of machines from the cloud.

5. the (agricultural) machines of the future are highly automated and probably in many cases driverless (autonomously operated).
6. the process chains will be economically optimized with the help of prediction models (e.g. based on “digital twins”).

## Conclusions

In summary, it can be said that machine and production processes are coordinated in the cloud. Man will then manage and monitor a complex multi-machine process and only intervene when necessary.

The production processes will be documented automatically throughout, so that a customer-oriented quality assurance is achieved. It is not yet possible to predict when exactly this future will take place. However, if you look at the innovations at agricultural machinery fairs, you can already find pieces of the puzzle of digital, sustainable agriculture. In any case, the trend towards digital agriculture is a model for other sectors of the economy - including raw material extraction! In Germany and most parts of the European Union the digital transformation of agriculture is seen as

**Fig. 2** The automation pyramid of agricultural production with autonomous, mobile agricultural machines in a closed process management circle (ERP/FRP: enterprise/farm resource planning, MES/AES: manufacturing/agricultural execution system)

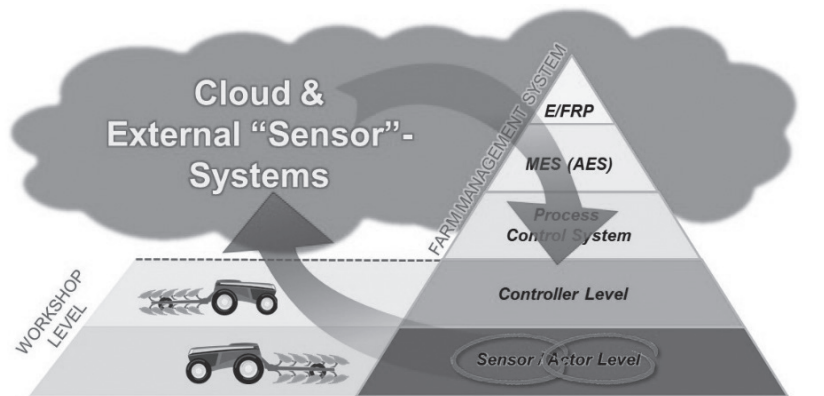



the key enabler to achieve a higher level of sustainability through minimizing inputs, maximizing yields and farmers' income, and others. The digital management of production shall finally lead to a circular agricultural economy. Thus, digitalization of agriculture is seen in Europe as a key enabler to achieve SDG 9 (Sustainable Development Goal "Sustainable Agricultural Mechanization and General Industrialization") of the United Nations declared in 2016. Agriculture in Germany is becoming "smart" and with this agricultural engineering is

becoming smart agricultural engineering [3]!

## LITERATURE

1. Committee for European Construction Equipment (CECE), European Agricultural Machinery Industry Ass. (CEMA) (2011): CECE and CEMA. Optimizing our industry 2 reduce emissions. Brussels, 31 pages
2. Liggesmeyer, Peter: Wie viel Industrie 4.0 braucht ein Unternehmen? (How much Industry 4.0

is needed for a Manufacturing Enterprise?) Fraunhofer-Blog, 29. Mai 2017. Link: <<https://blog.iese.fraunhofer.de/prof-liggesmeyer-wie-viel-industrie-4-0-braucht-ein-unternehmen/#:~:text=Die%20vierte%20industrielle%20Revolution%20ist,in%20kleinen%20Losgr%C3%B6%C3%9Fen%20kosteng%C3%BCnstig%20herzustellen.>> (called up on Aug. 7<sup>th</sup> 2020)

3. Peter Pickel: "Smart" agricultural engineering. LANDTECHNIK 73(6), 2018, pp. 177-178, DOI: 10.1515/lt.2018.3194

■ ■

*(Continued from page 81)*

## The Role of Life Sciences Universities in Relation and Strategy of Sustainable Development Goals

agriculture plot. Agronomy Research, 17(2): 447-455.

- Kic, P. and Zajicek, M. 2015. CFD model of regenerative heat exchanger. Agricultural Engineering International: CIGR Journal, vol. 2015(1): 80-93.
- Kroulik, M., Brant, V., Zabransky, P., Chyba, J., Krcek, V. and Skerikova, M. 2018. Machine monitoring as a SmartFarming concept tool. In: Proceedings of the 14<sup>th</sup> International Conference on Precision Agriculture, Montreal 24.-27.6. 2018, 10 p.
- Markonis, Y., Papalexiou, S. M., Martinkova, M. and Hanel, M. 2019. Assessment of water cycle intensification over land using a multi-source global gridded precipitation dataset. Journal of Geophysical Research-Atmospheres, 124 (21): 11175-11187.
- Mikolas, M., Svitok, M., Teodosiu, M., Nagel, T. and Svoboda, M. 2019. Land use planning based on the connectivity of tree species does not ensure the conservation of forest biodiversity. Land Use Policy, 83: 63-65.
- Polak, M. 2018. Determination of conversion relations for the use of small hydrodynamic pumps in reverse turbine operation. Agronomy Research, 16, (SI 1): 1200-1208.
- Review for social policy and research. 2019. <https://socialnipolitika.eu/2019/02/od-roku-2010-pocet-studentu-na-vysokych-skolach-klesl-o-100-tisic-pocet-studujicich-cizincu-vzrostl/> (in Czech)
- Sklenicka, P., Zouhar, J., Molnarova, K. J., Vlasak, J., Kottova, B., Petrzela, P., Gebhart, M. and Walmsley, A. 2020. Trends of soil degradation: Does the socioeconomic status of land owners and land users matter? Land use policy, vol. 95, Article Number: 103992.
- Zeman, P., Honig, V., Kotek, M., Taborsky, J., Obergruber, M., Marik, J., Hartova, V. and Pechout, M. 2019. Hydrotreated Vegetable Oil as a Fuel from Waste Materials. Catalysts, 9 (4): 1-16.
- Zewdie, R., Wallace, E. and Kic, P. 2015. Developing Countries in Africa and Priorities towards Implementation of Agricultural Mechanization. AMA-Agricultural Mechanization in Asia, Africa and Latin America, 46(2): 35-40.

■ ■

# Mechanization of Agriculture in Germany



by  
Peter Schulze Lammers  
Prof. em. Dr. Ing  
University of Bonn  
GERMAN

## Structure of Agriculture and Crop Production in Germany

Agriculture in Germany is characterized by 16.6 million ha of arable land and the most cultivated crop is wheat. All together cereals are grown on more than 8 million ha and the average acreage is 66.3 ha for farms > 5 ha (2016). 57% of the farms cultivate more than 100 ha. Other dominating crops are rape, and row crops as maize, sugar beet and potatoes (see **Table 1**). A major trend is the reduction of number of farms and increasing acreage per farm unit driving the up-sizing Ag machines (see **Table 2**). A similar impact on mechanization of agriculture in Germany comes from decreasing labor force employed on farms. Since reunification in 1990 the number of humans working in agriculture dropped by 45%. Currently 50% of the labor force in agriculture is farm owners and their family members. (BMEL, 2020)

Unique in Europe is the organization of machinery mission by “Mas-

**Table 1** Shares of main crop/cultivation groups, holdings > 5 ha (BMEL, 2020)

Type of crop	Share of acreage, %
Cereals	52.4
Fodder crops	24.5
Commodities	11.1
Row crops	5.7
Vegetables	1.2

chinenringe” of which there are 251 in Germany and additionally 5,850 contractors are part of the farm mechanization (BMEL, 2020).

Production value of agriculture in 2018 of agriculture accounted to 52,731 million – whereas 48% originated from arable and 52% from livestock farming. This profile defines the market for agricultural machinery and is a request for mechanization of field operations. (BMEL, 2020)

## Evolution of Mechanization

Mechanization as substitution of manual labor by physical tools is a characteristically identification of human culture. However, the handling of processes by machines started in agriculture only two hundred years ago. Threshing of cereal crop, as it is executed today worldwide by combines, started in Germany in the 1950<sup>th</sup>. The machine concept and design were already known from the United States. But these combines did not fit to the existing farms in Germany at that

time, with small acreage and lag of propulsion technology like later on the omnipresent internal combustion engines. The combines in the first years were driven and trailed by tractors; it very rapidly became a revenue for agricultural machinery manufactures.

The subsequent evolution was characterized by extending the capacity of agricultural machinery. Nearly every implement and machine were enlarged in size, power and mass in the 20<sup>th</sup> century. This trend is still ongoing and is in question because of the high wheel load in field traffic. The entire professional community and the politicians claim with an increasing extend at a disruptive change in agricultural practice not only for environmental aspects, energy saving but request a substitution of big machines working in the fields which seems to the majority of the society as not adequate for a sustainable agricultural practice.

Engineering already reflects these societal demands by improving the machine operations with electronics and sensors to make the technology more efficient and more precise. Pre-

**Table 2** Evolution of farm structure of agricultural, on arable land, holdings > 5 ha, (BMEL, 2015, 2020)

Year	Number of farms	Arable farm land, ha	Acreage per farm, ha per unit
1999	354,333	16,854,600	47.6
2010	271,783	16,650,000	61.3
2016	251,311	16,616,900	66.3

cision farming, smart farming and robot farming as emerging technology driven by engineers with deep knowledge in agricultural processes and crop farming enhance the efficiency of machinery operations. Beginning with the availability of the GNSS system, mobile computers and mobile telephones, progress in farm technology is triggered by electronics and digital communication.

Since the 1980s agriculture is fully mechanized and farmers invest predominantly for tractors followed by combines, tillage and other implements (see **Table 1**). As the yield is steadily increasing transport of agricultural goods in a short distance range has become a major mission of tractors.

### State of Mechanization in Agriculture in Germany

Part of mechanization of agriculture is the production of agricultural machinery. In Germany, there is a traditionally strong industry producing technical equipment for agriculture. As compared to entire machinery production, agricultural machinery had a share of 3.8% (2000) and 5% (2014) in Germany. The agricultural machinery manufacturers suc-

cessfully extended the production in the last two decades as can be seen from **Table 3**. The value of the total Ag-machinery production was in 2000 3,504 million €, in 2010 5,485 million € and in 2019 7,686 million €. Exports accounted for the greater part of this growth. Sales revenues of tractors increased by 92.5% from 2000 to 2010 and sales revenues of agricultural machinery by 74.7%. The growth of turnover is originated stronger from exports than from the domestic market and more from tractors than from agricultural machinery. (BMEL, 2005, 2020)

The last decades are characterized by a strong concentration of the sector. Small sized manufacturers appear in the spare part and supplier market, middle sized companies are producing implements and diverse technical equipment (e.g. potato and sugar beet harvesters, trailers, tillage implements sprayers) for crop and livestock farming, and the full-liner are international companies, all of them are producing the master machines tractors, combines, balers and choppers as well as other harvest equipment. The entire production of Ag machinery is listed in **Table 1**, demonstrating a steadily progress of revenues from 2002 to 2018. Major part of production is

generated by tractors by a share of approximately 45% in the regarded time span. From 2000 to 2017 the ratio of export to domestic tractor sells changed from 2.1 to 2.8, this ratio shall be for other Ag-machinery 1.4 to 2.8 indicating the increasing shares of production for external markets. The predominate market for German Ag-machinery companies is the European market, followed by the USA, and Russia. (BMEL, 2005, 2020)

The market for Ag-machinery in Germany reflects the investments in new technology by the farmers, collective farms and contractors (see **Table 4**). The major investments were in the last decades on tractors with an increasing trend. Harvest machines represent the second important market share whereof approximately 35% are investments for combines. The market for livestock farming machinery is low as compared to other machine groups. Need to be considered that under harvest machines a big share is for green fodder harvest. A remarkable amount of money is spent for spare parts and other machinery e.g. implements for landscape maintenance.

The tractor is still the key master machine on farms in Germany. The farmers spent most of their labor time in field work on tractors and most of the tractors are standard type characterized by steered front axle with smaller wheels and cabin position in the rear. Reducing of exhaust gas emission was a dominant target of engine design in the last decade, the Diesel engines use conditioners (AGR/DOC/DPF/SCR resp. DOC/SCRoF) to comply with the EU legislation on stage V. Extension of power is still a significant trend (standard tractor 380 kW) with low rated engine revolution of 1700 rpm (Stirnimann and Renius, 2020). In large and medium power tractors CVT transmissions and front axles with spring suspension are frequently obscured, primar-

**Table 3** Agricultural machinery production in million €, (BMEL, 2005, 2020)

Year	Ag- machinery production	Tractor, production	Tractor sales, domestic/export	Ag-implement sales, domestic/export
2000	3,504	1,592	510/1,082	781/1,129
2010	5,485	2,765	681/2,083	891/1,828
2018	8,626	3,986	1,040/2,946	1,230/3,413

**Table 4** Ag machinery revenues, 2000, 2010, 2017, market volume in million € (BMEL, 2005, 2020)

Year	2000	2010	2017
Tractor, including second hand	1,529	1,345	1,797
Tillage implements		171	248
Sowing and planting implements	6,422	170	248
Harvest machines	Ag-machinery,	587	757
here of combines	without tractors	210	259
Equipment for livestock farming	1,912	210	226
Transport, trailer		54	90
Other machinery, including spare parts		1,275	2,135

ily in combination with a high-end speed of 40 km h<sup>-1</sup>.

Registration of new and used tractors has increased in the last decades (see **Table 5**). Tractor units on farms slightly decreased as new tractors substituted more than one old unit resulting in 5.5 tractors per farm in 2019.

### Trends and Innovations

Electrification, digitalization, emission reduction and efficiency increase are the dominating topics in Ag engineering in the next decade. There is a significant trend from producing agricultural machines by long-liners and full-liners offering a wide range of mechanization equipment for arable land farming to smart agricultural machines, suppliers of connected agricultural machines. Farm management systems aim at a more efficient mission of agricultural machines by control and optimization of complex agricultural systems. Conventional agricultural machines will become a data source and sensor carrier and they need field wireless communication-based cloud technology. However so far only approximately 10 % of the farmers/farms use cloud technologies. In contrast 59% of the farmers use smartphones (Anonymous a, 2017). High efforts are spent by the agricultural machinery manufacturers to agree on standardization for machine to machine communication. The ISOBUS standardization is ongoing and need to be updated continuously.

Plant protection by more environmentally friendly methods will have a huge impact on the evolution of farm technology and can satisfy the societal requests on farming without chemical agents. Mechanical weeding is already relaunched with support of digital technologies.

A recent survey of experts revealed a notable contribution of controlled agricultural machines/

**Table 5** Tractor registrations -new and used units- and units on farms (BMEL, 2005, 2020, anonymous b, 2020)

Year	2000	2010	2017
Registration, new	23,815	32,809	29,011
Registration, used	49,987	68,951	-
Units on farms	1,584,000	1,219,861	1,368,938

robots in the western European market for 2045, but fully autonomous machines are regarded to become minor relevant until this time (Anonymous c, 2020).

### REFERENCES

Bundesministerium für Ernährung und Landwirtschaft 2020: Statistisches Jahrbuch über Ernährung Landwirtschaft und Forsten 2020, 59, Landwirtschaftsverlag Münster, BMEL, 2020 <https://www.bmel-statistik.de/landwirtschaft/tabellen-zur-landwirtschaft/>)

Anonymous a, 2020, Eilbote 42/2017

Anonymous b, 2020, Eilbote 27/2020

Anonymous c, 2020 Die total autonomen Roboter kommen. Fraunhofer IESE/ Kleffmann Group, Eilbote 23, 16-17

Stirnemann, R. and Renius, K., 2020. Gesamtentwicklung Traktoren. Jahrbuch Agrartechnik 2019. Braunschweig: Institut für mobile Maschinen und Nutzfahrzeuge Frerichs, L. (Hrsg.), 1-13



# The Role of Life Sciences Universities in Relation and Strategy of Sustainable Development Goals



by

P. Kic

Faculty of Engineering,  
Czech University of Life Sciences Prague,  
165 21 Prague 6  
CZECH REPUBLIC  
kic@tf.czu.cz

## Abstract

The seventeen Sustainable Development Goals (SDGs) that make up the United Nations Development Program for the coming years set out the basic direction of the basic components and factors of human society for the period up to 2030 towards sustainable development. However, as has happened several times in history, well-thought-out slogans and principles will remain mere proclamations at the top of the pyramid of human society, unless they are grasped by humanity as a whole and addressed from the ground up in the widest possible area of the largest possible population. The aim of this article is to demonstrate the possibilities that systematic education, science and research offer to humanity in this direction in a system summarized in one complex unit called the University of Life Sciences on the example of the Czech University of Life Sciences Prague.

**Keywords:** Agriculture, development, education, engineering, food, life quality, world

## Introduction

The basic ideas, summarized in seventeen Sustainable Development Goals (SDGs), are very important for the direction of scientific, re-

search, but also pedagogical activities of universities, scientific societies and subsequently in applications in manufacturing companies and in real operations and life. Undoubtedly, material support is very important for many areas and many countries, but without education and the involvement of science and research, the proper results cannot be achieved. The focus of scientific work and the preparation of the young generation for solving the global problems of human society are the basic preconditions for their solution and successful management. It is already clear that universities will have an increasingly strong position in this respect, providing a comprehensive education that includes as many factors as possible involved in addressing the seventeen goals.

## Materials and Methods

This article will try to show on the example of the Czech University of Life Sciences Prague (CULS) how the University of Life Sciences contributes to the solution of the Seventeen Goals of Sustainable Development. The Czech University of Life Sciences Prague is an active member of Euro-league for Life Sciences (ELLS) which is a network that consists of seven European member universities and three non-

European partner universities. In addition to the Czech University of Life Sciences Prague the other ELLS member universities are: University of Natural Resources and Life Sciences, Vienna; University of Copenhagen, Faculty of Science; Swedish University of Agricultural Sciences; University of Hohenheim; Wageningen University and Research Centre and Warsaw University of Life Sciences.

ELLS Partner Universities which play very important role in ELLS development are: Cornell University, College of Agriculture and Life Sciences; China Agricultural University, Beijing; Hebrew University of Jerusalem, Robert H. Smith Faculty of Agriculture, Food and Environment; and Lincoln University, New Zealand.

Very important ideas which also creates the theoretical background of this article are summary ideas discussed by many members of the Club of Bologna in their Meetings during more than 30 years and presented in Meetings Proceedings (1989-2019).

## Results and Discussion

The CULS Prague and generally studies of life sciences in the Czech lands have a more than hundred years tradition. The first faculty of Agriculture was established at

the Czech technical University in Prague as early as 1906. Currently the Czech University of Life Sciences Prague has more than 18 000 students (10% are international students), studying in more than 170 accredited study programmes at BSc, MSc and PhD levels (in 9 BSc, 20 MSc and 18 PhD programmes the language of instruction is English).

The whole academic community consists from six Faculties and one Institute: Faculty of Agrobiology, Food and Natural Resources; Faculty of Economics and Management; Faculty of Engineering; Faculty of Environmental Sciences; Faculty of Forestry and Wood Sciences; Faculty of Tropical AgriSciences; and Institute of Education and Communication.

The scientific, research and pedagogical activities of the individual faculties complement each other and thus create a comprehensive background for the fulfilment of the seventeen goals of the SDGs. The overview shows the importance of technology for the development and solution of the following seventeen goals of SDGs and emphasizes the important position of the Faculty of Engineering, which in some areas, thanks to the deep theoretical background necessary for the development of technology, forms the basis for achieving the following goals.

Eradicating Poverty in the World as a **Goal 1: No Poverty** “End poverty in all its forms everywhere.” is a fundamental, global task, and other related goals are closely related to it. It is a relatively easy to measure goal, as a minimum income per person per day can be used as a criterion to assess it, but the efforts of many sectors of the economy are needed to achieve it. Raising the standard of living of all people, families, even in the poorest states, requires radical interventions in the economy and socio-economic structure in these states, as well as cooperation with developed countries

aimed at solving this task. In this context, it is an indisputable advantage that the Faculty of Engineering is a part of the CULS, which covers the main branches of Life Sciences. The development of agriculture, the development of industries in areas corresponding to local conditions, the efficient sourcing and use of available raw materials for the benefit of the local population leads to an increase in people’s employment, and thus to a regular income.

Humanism, a high standard of living for all workers and the provision of basic needs for normal life as well as for the sick and disabled are the subject of **Goal 10: Reducing inequalities** “Reduce income inequality within and among countries”, as seen by students from less developed countries in Africa, Asia and Latin America during their studies in the Czech Republic. A good example of the peace policy development them is that the Czech Republic has never threatened other states, never owned or exploited colonies. This also reliably fulfils **Goal 10: Reducing inequalities** “Reduce income inequality within and among countries.”

Agriculture is still the largest source of income and jobs for poor rural households. Ensuring enough food for an ever-growing number of people in the world is only possible through the development of agriculture. It is bad that the area of agricultural land is constantly declining at present. That’s why **Goal 2** is: Zero hunger “End hunger, achieve food security and improved nutrition, and promote sustainable agriculture”. The principal questions of land management and land-use policy are solved by specialists from the Faculty of Ecology (e.g. Sklenicka et al., 2020). Although the world’s total food production is sufficient, one in nine people in the world still suffers from malnutrition. The vast majority of starving people live in developing countries (especially in Asia and Africa), where they also

have the largest increase in population. At the same time, children and adolescents are most at risk, malnutrition is responsible for the deaths of almost half of children under the age of five, and tens of millions of children around the world routinely go hungry to schools.

Most of the food consumed in the world comes from small farms. Investment in small-scale agriculture is thus beneficial for developing countries, not only in terms of supporting jobs, but also in terms of improving the nutrition of the population and averting famine. Thus, despite the significant progress made in the past with the contribution of the international community, the current situation is very serious. Experience from developed countries shows that the production of basic types of food, such as cereals, can be provided much more efficiently on large farms, with efficient and effective technology. A comparison of the different intensity of food production between developed and developing countries shows that the development of food production, i.e. the development of agriculture in terms of quantity and quality, will not be possible without the transfer of scientific knowledge into agricultural practice (e.g. Jelinek et al. 2019). The use of agricultural machinery plays a key role here. Achieving this “**Goal 2**” is therefore one of the key tasks and the role of Universities of Life Sciences is irreplaceable.

Achieving **Goals 1** and **2** is very closely linked to sustainable, inclusive and sustainable economic growth, which is the content of **Goal 8: Decent work and economic growth** “Promote sustainable, inclusive and sustainable economic growth, full and productive employment and decent work for all.” The second part of this goal is also important. The economic growth of a company should be directed permanently towards the welfare of society, but it is necessary to pay

attention to its form and working conditions. It should be noted that the Czech Republic is one of the countries with the lowest unemployment in the world. Graduates of the Faculty of Engineering always find a good and interesting job and have no problems with unemployment. The curriculum at CULS and other Universities of Life Sciences also includes the study of sociology, ergonomics, work environment technology and occupational safety. In many countries, especially developing countries, these aspects are not yet sufficiently respected and put into practice.

Human beings have the right to a healthy and productive life that is in harmony with nature. Therefore, it is listed as **Goal 3**: Good health and well-being for people “Ensure healthy lives and promote well-being for all at all ages.” Health is a condition of a happy life for every individual, but not only that. How the health of man, but also of broad sections of the human population is related to the economic side of life and the prosperity of human society will be best manifested in crisis situations. Humanity is now experiencing this situation at the moment. The deep-seated pandemic caused by coronavirus COVID 19 has harmed life around the world in both developed and developing countries without exception, since early 2020. Virology specialists at Universities of Life Sciences are involved in identifying, diagnosing and finding treatment options for these diseases, in accordance with **Goal 3**. E.g. the new CULS research centre in Prague will focus on the transmission of COVID-19 and other infectious diseases between animals and humans (Currently Covid-19, 2020). The difference is in how governments in different countries can take responsibility and address situations beyond the reach of the individual. Systematic and minimizing the consequences for the population in terms of health impacts, but also

economic is a certain indicator that has made visible the readiness and ability of the leadership of states and their populations to deal with crisis situations in various countries around the world.

**Goal 4**: Quality education “Ensure inclusive and equitable quality education and promote lifelong learning opportunities for all” is quantitatively fulfilled in many countries, but the focus and quality of education is debatable. The percentage of people who have at least a basic education in the world is slowly but surely increasing. The share of high school and university graduates is also increasing.

However, the focus of the study and the possibility of application after the study remain problematic. The basic qualifications needed for the population in developing countries must provide education that they can apply in the necessary professions, which are qualified workers in technical professions, craftsmen, repairers ensuring a quality maintenance system. These professions are lacking in many countries, and yet they are the basis of the function and development of industry and agriculture (Zewdie et al., 2015) The education and training of these employees cannot be ensured by the University’s humanities, such as philosophy, political science, sociology, or by deeply specialized education in other academic fields, for the further development and research of which they are not in development conditions or employment. Educated people from these fields are aware of many problems in society. However, the narrow focus of these non-technical fields does not give graduates enough information to solve these fundamental and practical problems in often complex situations, especially in developing countries. Preparatory studies at general secondary schools, such as various grammar schools and lyceums, are also insufficient, after which some young people may be able to study

at universities, but most are unable to find practical employment in the necessary professions.

From this point of view, it is therefore necessary to develop a practice-oriented study, which is provided in many fields, especially at the University of Life Sciences. The graduates of these universities collectively represent an educated group of the population, which has the prerequisites and education not only to analyse problems, but also to successfully solve them in the demanding conditions of contemporary unbalanced human society. It would be desirable for graduates of Universities of Life Sciences to be more involved in state governance and international policy solutions. It is gratifying that some CULS Prague graduates are active in high state governmental, diplomatic and international positions.

In addition to the classic three-level education (Bc., M.Sc. Ph.D.) in many accredited fields, the education system complements Lifelong Learning, which takes place in full-time or part-time form of study, as specialized, retraining, extension, supplementary education. Courses, professional camps, educational cycles, seminars, lecture cycles, etc. take place on the premises of the university or in distance learning centres.

Equality between men and women should be evident not only in rights and responsibilities, but also in opportunities for the adequate development of each person’s personal potential writes in **Goal 5**: Gender equality “Achieve gender equality and empower all women and girls.” The problem of developing countries is mainly in the smaller share of girls who achieve at least basic education and in the possibility of their further employment in the labour market. The example of the Czech Republic shows that the share of girls among university students is growing. According to the Review for social policy and research (2019)

women have long accounted for more than half of the students (56%) and graduates (60%) of universities in the Czech Republic. Last year, almost 168,000 women studied at universities.

In addition to food, water is a basic condition of life and an irreplaceable need of humanity. **Goal 6:** Clean water and sanitation “Ensure availability and sustainable management of water and sanitation for all” is an important area of study and research at all Universities of Life Sciences. The uneven distribution of water in individual parts of the globe and continents is mainly due to climatic conditions. The water cycle in nature works seemingly without human influence, however, humanity can systematically interfere with the distribution of water and achieve better use.

The study of fields focused on the environment includes as a very important part of the study and research activities the issue of water management in terms of finding resources, water management in the landscape in connection with agricultural production and water supply and its use for urban consumption and industry. This issue is part of the study at faculties and departments focused on the environment, agrobiolgy and technology within the Universities of Life Sciences (e.g. by Hu et al., 2019, Markonis et al., 2019), especially focusing on the global problems of water cycles, movement of water in the soil, design of irrigation systems and design of land reclamation equipment for drainage, construction and design of pumping stations for irrigation and water supply. In recent years, research experience in these areas has been used both in the conditions of developing countries suffering from permanent water scarcity and in Central European conditions, which is also related to climate change, which is reflected in water scarcity and inequality in some periods and areas.

With the development of modern human society, energy consumption is also growing enormously. At the same time, traditional fossil resources (oil, natural gas and coal) are declining radically, and their combustion in various forms of consumption usually also results in environmental pollution. The unequal distribution of reserves of this natural wealth in the world also leads to international conflicts and, under various pretexts, sometimes to war conflicts. **Goal 7:** Affordable and clean energy “Ensure access to affordable, reliable, sustainable and modern energy for all” is therefore one of the important goals.

The combination of agrobiological and technical sciences is constantly going to better and more efficient use of land not only for food production, but also for the production of energy crops. Laboratories of the Faculty of Engineering in CULS Prague are testing new generation fuels for various types of internal combustion engines (e.g. Zeman et al., 2019). Other important research activities are focused on the development of more efficient photovoltaic cells (e.g. Beranek et al., 2018), solar collectors and the construction of a new, more efficient water turbine (e.g. Polak, 2018). The development and research of the construction of agricultural and food machines is focused not only on improving, optimizing and automating the operation of this technology, but also on reducing energy consumption (e.g. Kic and Zajicek, 2015).

Teaching the population to manage energy properly is a necessary condition for reducing its consumption. A large area in this direction is Heating, Ventilation and Air-conditioning (HVAC), affecting the population in countries with cold climates (energy savings for heating), as well as hot climates (energy savings for AC), industry and agriculture (need for intensive ventilation and in many cases HVAC). The

future can also be found in “passive air conditioning”, the principles of which include the use of shading by tree greenery in cities, the construction of “green roofs” with suitable plants and the use of water areas, (e.g. Cao and Kic, 2019). Mainly Faculty of Engineering, Faculty of Agrobiolgy, Food and Natural Resources and Faculty of Environmental Sciences are the leaders of these research activities included in **Goal 11:** Sustainable cities and communities “Make cities and human settlements inclusive, safe, resilient, and sustainable.”

Technically oriented Departments of CULS focused on planning and optimization of industrial zones, distribution and transport networks and other infrastructures are guarantors of teaching in areas corresponding to **Goal 9:** Industry, Innovation, and Infrastructure “Build resilient infrastructure, promote inclusive and sustainable industrialization, and foster innovation.” However, human society must focus not only on the constant increase in production, but also on the balance between other sectors such as services for the population and, for example, the issue of waste treatment. Human society is constantly producing more and more waste (organic, inorganic and liquid) that needs to be consistently collected, sorted and treated, such as recycled. Each Faculty at CULS teaches a field of study focused on this issue, incorporated into **Goal 12:** Responsible consumption and production “Ensure sustainable consumption and production patterns.”

A very important area of research activities and educational processes, especially with a direct impact on the practice and life of the population is **Goal 13:** Climate action “Take urgent action to combat climate change and its impacts by regulating emissions and promoting developments in renewable energy.” The quality of the environment, especially the air, is analysed in terms



of reducing pollution, e.g. transport and energy means, technological processes in agriculture and industry. Methods and technical solutions for reducing the impact and effect of pollutants in workplaces are sought. In this context, attention is paid to climate change and its effects (e.g. Francova et al., 2017).

One of the basic missions of Universities of Life Sciences is the issue addressed in **Goal 15: Life on land** "Protect, restore and promote sustainable use of terrestrial ecosystems, sustainably manage forests, combat desertification, and halt and reverse land degradation and halt biodiversity loss." Many Departments of CULS mainly solves biological, ecological issues in this extensive and fundamental issue (e.g. Mikolas et al., 2019). However, quality technical support, respecting all the requirements of ecologists, is very important for sustainable management. Thanks to the Faculty of Engineering and the cooperating departments of other CULS faculties, the development of precision agriculture is becoming not only an important area of research, but also a common practice in many agricultural enterprises with intensive production (e.g. Kroulik et al., 2018).

Universities all over the world are a form of vanguard of society and, in addition to professional subjects and scientific disciplines, they also teach young people how to work together and get to know human society abroad. CULS in Prague has a large number of contracts with many Universities around the world. All faculties have several fields of study that are taught in English and the publishing activity is also predominantly in English. Many students, as well as teachers, study or work in foreign universities as part of cooperation, and vice versa, more and more foreign students are studying at the CULS.

This form of internationalization and mutual acquaintance with other students and other scientific work-

places creates preconditions for ever-improving relations with foreign countries and purposeful international cooperation and fulfilment of goals, which are listed under Goal 16: Peace, justice and strong institutions "Promote peaceful and inclusive societies for sustainable development, provide access to justice for all and build effective, accountable and inclusive institutions at all levels" and **Goal 17: Partnerships for the goals** "Strengthen the means of implementation and revitalize the global partnership for sustainable development."

## Conclusions

The current, and obviously, future development of human society is characterized by an ever-growing population, a reduction in the area of agricultural land, a loss of natural energy resources and an overall deterioration of the environment. The solution requires increasing food production, exploring more efficient renewable energy sources, finding ways to improve the environment and working together to meet all the goals set out in 17 Sustainable Development Goals, SDGs.

The findings of this article show that in order to fulfil these 17 Goals, it is necessary to increase the education of the human population and to solve research tasks in these areas. The example of the Czech University of Life Sciences Prague shows that the Universities of Life Sciences have the prerequisites for solving and meeting these requirements, which include biological, technical, ecological and aspects of the practical economic needs of human society in their activities. It will therefore be very important to create conditions for their scientific and professional activities, for mutual cooperation between Universities of Life Sciences and other scientific institutions and to transfer their knowledge and ideas to all de-

veloped and developing countries of the world.

## REFERENCES

- Beranek, V., Olsan, T., Libra, M., Poulek, V., Sedlacek, J., Dang, M. and Tyukhov, I. 2018. New Monitoring System for Photovoltaic Power Plants' Management. *Energies*, 11(10): 1-13.
- Cao, V. D. and Kic, P. 2019. Effect of shading with trees to improve local temperature conditions. In: *Proceedings 18th international scientific conference Engineering for Rural development*. Jelgava, 2019, 1423-1429.
- Club of Bologna. Meetings Proceedings. 1989-2019. <https://www.clubofbologna.org/en/meetings-proceedings.php>
- Czech University of Life Sciences Prague (CULS). 2020. <https://www.czu.cz/en/>
- Currently Covid-19. Czech University of Life Sciences Prague. 2020. <https://www.czu.cz/cs/r-7229-aktuality-czu/nove-vyzkumne-centrum-czu-se-zameri-na-prenos-covid-19-a-dal.html> (in Czech).
- Francova, A., Chrastny, V., Sillero-va, H., Vitkova, M., Kocourkova, J. and Komarek, M. 2017. Evaluating the suitability of different environmental samples for tracing atmospheric pollution in industrial areas. *Environmental Pollution*, 220: 286-297.
- Hu, S., Chen, Z., Chen, K., Huang, L., Zuo, X., He, J. and Chen, Y. 2019. Purification of leachate from sludge treatment beds by subsurface flow constructed wetlands: effects of plants and hydraulic retention time. *Environmental Science and Pollution Research* 26, 5769-5781.
- Jelinek, Z., Stary, K. and Kumhalova, J. 2019. Assessment of production zones modelling accuracy based on satellite imaging and yield measurement of selected
- (Continued on page 73)*

# Serbian Agriculture, Agricultural Engineering – Past and Future



by  
M. Martinov  
Faculty of Technical Sciences,  
Chair of Biosystems Engineering,  
Novi Sad  
SERBIA

Dj. Djatkov  
Faculty of Technical Sciences,  
Biosystems Engineering,  
Novi Sad  
SERBIA

S. Bojic  
Faculty of Technical Sciences,  
Biosystems Engineering,  
Novi Sad  
SERBIA

M. Viskovic  
Faculty of Technical Sciences,  
Biosystems Engineering,  
Novi Sad  
SERBIA

From the very beginning AMA, as only worldwide available R&D oriented journal, used to practice charitable work, to help underdeveloped and developing countries in the domain of agricultural engineering. And this, fifty years continuously. Congratulations, many thanks and best wishes for the future (Milan Martinov).

## Past – Development of Mechanization

Fifty years ago, Serbia was part of the Socialistic Federative Republic of Yugoslavia. It is not widely known that agricultural land was not nationalized, like in other socialistic/communistic countries, but about 85% was owned by farmers. However, the land property was limited to 10 hectares. Other legal entities were, so called, agro-industrial combines and cooperatives.

The first step, aimed to reduce farmers' drudgeries, was, so called, *tractorisation*. At the seventies of the former century started, based on the *Massey Ferguson* license,

domestic production of tractors by IMT factory. (Getting permission for such arrangement for license production was possible due to the special status of Yugoslavia, which was not a member of the East European block.) Manufacturing started with the smallest tractor, about 30 hp (**Fig. 1**), and finalized with big one, about 250 hp. Some of smallest are still running.

Production was huge, reaching in one year almost 46 thousand tractors. Considerable amount was exported, by the affordable prices, to non-aligned countries in Asia, Africa and South America.

The same happened with the production of combined harvester,

mostly sold to big combines. Few domestic companies developed and manufactured, for the most significant crop, a special machine, i.e. corn ears picker (**Fig. 2**). These were used by family farms, and ears were naturally dried. Corn cobs, remained after threshing those were used as a fuel, mostly for residential heating and cooking. This harvest technology also exists today but in a considerably smaller volume.

Domestic industry developed and manufactured implements for soil tillage, seeder, crop care, etc. The industry of agricultural machinery played a significant role in the national economy.

Big combines started also to

**Fig. 1** Smallest IMT tractor, 33 hp



**Fig. 2** Typical corn ears picker



import contemporary machines manufactured by reputable European and US companies. At the end of the socialistic era, most of the big combines were supplied with up to date agricultural machinery and performed farming on a high level.

It could be concluded that the supply of agricultural mechanization was appropriate, and enabled, in that time, profitable agricultural production.

## Current Situation

After the split of Yugoslavia, Serbia became an independent state. From point of view of agriculture, it was only one of the new states with sufficient agricultural land and respective production. Agricultural land is, according to FAO 2012 (<http://faostat.fao.org/site/377/DesktopDefault.aspx?PageID=377#anchor>) about 5.05 million ha, and arable land about 3.3 million ha. Agricultural production plays a significant role in the national economy, and continuously creates considerable export/import surplus.

Farm size is not limited, which enables profitable production on bigger plots. Some farmers are specialized in giving high-quality services to others, which enables the profitable utilization of modern machinery.

Speaking about field production farming on small plots that become non-profitable. For many owners of small acreage is a financial benefit

**Fig. 3** Example of locally developed and manufactured roller crimper



to rent own land. It is more profitable than to perform farming with outdated machinery. This led toward the growing of plots and enabled profitable utilization of high-tech machinery, including environment protection effects.

The national agricultural machinery industry restructured crucially. Big national companies have disappeared, but number of small and medium companies, SMEs, increased. Best of them supply not only the national market, but use to export products, first to neighboring countries.

The subsidies for farmers are, in comparison with European Union countries, on modest level. Supported are farms with less than 20 ha, young and women farmers. Purchase of agricultural machinery and equipment is also subsidized, newly also by EU IPARD program.

## Special Technologies and Machinery

Beside traditional agricultural production and machinery, R&D institutions and manufacturers, mostly SMEs, focus on new, innovative technologies and products. These are using the advantage of relatively inexpensive R&D staff, whereby, priority is the development of low-cost solutions.

One example is production of special crops, typically medicinal and aromatic, which have a significant role in national agriculture. This also enables to obtain higher income on smaller acreage. The development of special machinery and equipment for this production is a niche market of small companies. This also includes machinery for fruit and vegetable production, tobacco and similar. Few small companies developed products which are exported worldwide.

Typical, niche market example, is locally developed roller crimper (**Fig. 3**), aimed for processing of mulch, e.g. cover crops, with effects of an increase of soil organic matter

SOM, and carbon SOC. This is well known measure for preservation of soil fertility and other positive effects.

## Renewable Energy Sources

Agriculture plays important role in this sector. For household heating, crop residues are used covering about 0.4 Mtoe (million tons of oil equivalent), of total about 4 Mtoe of primary energy consumption.

Recently, biogas is becoming a booming sector, whereby over 90% of substrates are coming from agriculture and food processing. Only the production of transport biofuels sector is at a low level.

## National Strategy and Visions

Serbia, as a candidate for membership of European Union, should follow EU policy, including that related to agriculture sector. The newest EU document, relevant for agriculture, is *European Green Deal*, announced in 2019, which treats biomass as a future feedstock for diverse products.

National RIS3 (*Research and Innovation Smart Specialization Strategy*) included agriculture and food processing in strategic sectors. This is related to agricultural engineering as well.

Including with previous, the most important keywords are:

1. Sustainability, which includes environmental, economic and social aspects.
2. Innovation, which includes technologies and machinery.
3. Bioeconomy, including utilization of biomass as a feedstock for diverse products.
4. Circular economy, i.e. circular bioeconomy (defined in EU document: European Environment Agency, 2018, *the circular economy and the bioeconomy Partners in sustainability*).

(Continued on page85)

# Sustainable Development of Chinese Agriculture and Food Security



by  
Chen Zhi  
China Association of Agricultural Machinery  
Manufacturers  
chenzhi1955@qq.com

Food security is the essential basis for economic development, social stability, and state security. China has a large population and lacks arable land and water resources on which food production depends. With a population of nearly 1.4 billion, ensuring national food security has always been the major national strategy for China. China's annual grain consumption exceeds 700 billion kilograms, and the global annual grain trade volume is 400 billion kilograms. China can only solve the food problem on its own. Therefore, China has always attached importance to agricultural production and agricultural mechanization. In 1959, Chairman Mao Zedong proposed "The fundamental way out for agriculture lies in mechanization." Since the 21<sup>st</sup> century, agriculture and agricultural mechanization in China have enjoyed further development and made outstanding achievements. Since 2015, grain production has kept at more than 650 billion kilograms for four consecutive years, and the per capita food occupancy has exceeded 450 kilograms. In 2019, the self-sufficiency rate of the three major grains of rice, wheat and corn reached 98.75%, and the monitored qualified rate of major agricultural products reached 97.4%. China has solved the food problem on its own, using about 8% of the world's arable land to solve the food security problem of about

20% of the world's population.

These achievements are inseparable from the rapid development of China's agricultural machinery industry. Today, China can produce more than 4,000 agricultural machinery products in 14 categories, 50 subcategories, and meet 90% of China's agricultural machinery market demand. The country's total agricultural machinery power is 1 billion kilowatts. It has 190 million units of agricultural machinery, 42.49 million agricultural machinery households and service organizations nationwide, more than 50 million agricultural machinery employees, and more than 1 billion mu of effective irrigation area of farmland. The comprehensive mechanization rate of the cultivation and harvest of China's main crops exceeds 70%. Among them, whole process mechanization has been basically realized for major food crops such as rice, wheat and corn. China has become the world's largest agricultural machinery manufacturer and user country, effectively liberating rural labor force, ensuring stable development of agriculture, tapping the potential for increasing food production, leading the improvement of the farming system, and promoting the integration of agricultural technology, cost-saving, efficiency boosting and scale operation, thus accelerating the process of

agricultural modernization.

China also achieved good spill-over effects in helping other developing countries solve the problem of food security. China has established agricultural technology demonstration centers, agricultural technology test stations and promotion stations in over 100 countries in the world, and sent tens of thousands of agricultural experts to help these countries train their agricultural engineers, making great contributions to global food security and agriculture development of the world.

However, compared with developed countries, there are still many problems in the development of agriculture and agricultural mechanization in China. For example, the mechanization level of cash crop planting, animal husbandry, fishery industry, pre-processing of agro-products and facility agriculture is very low. The mechanization level in the hilly and mountainous areas in southeast China is still very low. Single-unit agricultural machinery is relatively small, and agricultural production scale is also small. The agriculture industrial structure is not so reasonable with low efficiency and quality.

At present, all kinds of unexpected factors, such as the Covid-19 pandemic and extreme weather have

brought about more uncertainties to the global agricultural production and given rise to people's worries about global food shortage. In September 2015, the United Nations Conference on Sustainable Development adopted the 2030 Agenda for Sustainable Development, which covers 17 development goals in areas of people's livelihood, environment, economy, ecology, and agriculture. In September 2016, China released national plan for the implementation of the "2030 Agenda for Sustainable Development", which reviewed China's achievements and experiences in implementing the Millennium Development Goals, analyzed the opportunities and

challenges faced in advancing the implementation of the Sustainable Development Agenda, and clarified the guiding ideology, general principles and implementation path of China's implementation work, and elaborated on China's specific plan for implementing 17 sustainable development goals and 169 specific goals in the future, and proposed the explicit requirements for the implementation of "eliminating hunger and achieving food security".

China's agricultural production system is undergoing historic changes. Increasing food production will rely more on technological progress rather than resource input. Cur-

rently, soil improvement, water consumption reduction, and fertilizer and pesticide application are being controlled; land transfer is being accelerated to build large-scale modern farms, and scale planting efficiency will be further improved. China's agricultural machinery is developing toward automation, intelligence, environmental protection and sustainability, and precision agriculture can further increase the grain output of China. China is confident and capable of solving the food problem of 1.4 billion people, and will contribute to the "China Plan" for world food security. ■■

(Continued from page 83)

## Serbian Agriculture, Agricultural Engineering – Past and Future

Most research and development efforts are oriented toward listed aspects and objectives. One example is the ongoing S3 Cluster project, part of *Danube Region Programme* of EU.

### UNO Sustainable Development Goals

Practically, all EU and national strategies are sound with UNO 2030 Agenda for Sustainable Development Goals (SDG).

FAO stated following strategic objectives (publication *FAO* and the *17 Sustainable Development Goals*, 2016):

1. Help eliminate hunger, food insecurity and malnutrition.
2. Make agriculture, forestry and fisheries more productive and sustainable.
3. Reduce rural poverty.
4. Enable inclusive and efficient agricultural and food systems.
5. Increase the resilience of liveli-

hoods to threats and crises.

Including with this, out of 17 SDGs are tackled following: 1, 2, 6, 7, 12, 13, 14, and 15. Serbia, i.e. Serbian agriculture, can contribute the following SDGs:

2. End hunger, achieve food security and improved nutrition and promote sustainable agriculture. *Increase of productivity, food safety and quality.*

7. Ensure access to affordable, reliable, sustainable and modern energy for all.

*Biomass: two third of this coming from agriculture, making over 60 % of renewable energies potential in the country. Recently, the utilization of agricultural products and by products is focused for non-food goods and bioeconomy.*

12. Ensure sustainable consumption and production patterns.

*This goal is under development, mostly by supporting circular*

*economy.*

13. Take urgent action to combat climate change and its impacts.

*Savings of energy and introduction of good agricultural practice and organic production is strongly focused and supported.*

15. Protect, restore and promote sustainable use of terrestrial ecosystems, sustainably manage forests, combat desertification, and halt and reverse land degradation and halt biodiversity loss.

*This aspect is now being discussed, but concrete actions still missing. Especially, regarding preservation of agricultural land fertility.*

R&D institutions, manufacturers of agricultural machinery and equipment are interested in international cooperation and are export oriented. ■■

# 50 Years of Agricultural Mechanization in China

by

Yang Minli

China Agricultural University,  
Beijing  
CHINA

Li Minzan

China Agricultural University,  
Beijing  
CHINA

Luo Xiwen

South China Agricultural University,  
Guangzhou  
CHINA

## Abstract

China is a large agricultural country and agriculture is the foundation of the national economy, with hilly and mountainous areas accounting for more than 60%. Most are run by small farmers, but there is also some development of agricultural cooperatives, agricultural machinery cooperatives and family farms. Since 1970, great achievements have been made in the development of agricultural mechanization in China in the past 50 years. China's agricultural machinery and equipment holdings, agricultural mechanization operation level, socialized service level have improved rapidly. China has made major breakthroughs in scientific and technological innovation in agricultural mechanization, and has been significantly enhanced in international cooperation and exchanges. China has a sound legal, regulatory and policy system for agricultural mechanization. Agricultural mechanization has provided strong support for China's food security, the transfer of agricultural labor force, the improvement of agricultural labor productivity, the rapid development of urbanization, and the modernization of agriculture and rural areas. A road of agricultural mechanization has been formed with Chinese characteristics. The environment of China's economic, technological and policy for agricultural mechanization development continue to improve. The priorities of future agricultural mechanization will be placed at developing resource- and

labor-saving technologies, shifting focus from production to higher efficiency, as well as from single technologies to integrated technologies, and trend to intelligent agriculture, intelligent agricultural machinery development. The role of agriculture will become much more significant to national economy for it to keep high growth rate.

**Keywords:** agricultural mechanization, agricultural machinery, modern agriculture, development, China

## Introduction

Theodore W. Schultz, an American agricultural economist, thought that agriculture would become the economic growth power if the traditional agriculture could be transformed into modern agriculture in developing countries. China is a big agricultural country with large population, the development of modern agriculture is a significant contribu-

tor to the wellbeing of the Chinese people. Agricultural machinery and equipment provide the base of material technology for modern agriculture, and agricultural mechanization is a major content and one of the main indicators of agricultural modernization. The Chinese government always attaches great importance to agricultural mechanization development, and agricultural mechanization becomes important support to promote the transformation of agricultural development methods, to improve agricultural labor productivity and agricultural comprehensive production capacity in China.

## Agriculture Situation

In 2019, China's agricultural population was 551.6 million people, about 39.4% of the total population. The proportion of employees in primary, secondary and tertiary industry were 25.1%, 27.5%, and 47.4%

**Table 1** Proportion of employment in primary, secondary and tertiary industries in China from 1970 to 2019 (%)

Years	Primary industry	Secondary industry	Tertiary industry
1970	80.80	10.20	9.00
1975	77.20	13.50	9.30
1980	68.70	18.20	13.10
1985	62.40	20.80	16.80
1990	60.10	21.40	18.50
1995	52.20	23.00	24.80
2000	50.00	22.50	27.50
2005	44.80	23.80	31.40
2010	36.70	28.70	34.60
2015	28.30	29.30	42.40
2019	25.10	27.50	47.40

Source: *China Statistics Yearbook*.

respectively in 2019 (**Table 1**), and the composition of gross domestic product of primary, secondary and tertiary industry were 7.1%, 39.0%, and 53.9% respectively in 2019. China's per capita agricultural labor productivity was CNY36,238.72 (2019, **Table 2**), nearly 9 times that of 1970. The annual net income per farmer reached CNY16,021 in 2019, 120 times that of CNY134 in 1978.

China has a total arable area of 135 million ha with hilly mountain area of more than 60%. Total sown areas of farm crops was 166 million ha, of which 116 million ha are for grain crops, i.e. 69.8% of the total sown area, and the yield per unit area was 5,720 kg/ha in 2019. The total sown area of corn, rice and wheat was 80% of the sown area of grain crops, and sown areas of corn, rice and wheat were 34%, 27% and 21% of total sown area of corn, rice

and wheat respectively in 2019.

China's per capita arable land and fresh water resources are rather low, at the levels of only 25% and 40% of the world's average. China's per capita arable land availability is 0.08 ha, far below the world average of 0.24 ha. But China's total output of grain, vegetables, fruits, meat and aquatic products respectively ranks first in the world. In particular, China's grain output reached 663.84 million tons in 2019, 2.77 times that of 1970 (**Table 3**). It would not have been possible to achieve these gains without the rapid development of agricultural mechanization.

Since 1970, it is the transformation of agricultural production mode caused by the extensive application of agricultural machinery in agricultural production that has greatly improved agricultural labor productivity and effectively guaranteed

China's agricultural development and food security. Without the development of agricultural mechanization, it would be difficult to feed such a large population as China's population increased from 0.8 billion in 1970 to 1.4 billion in 2019. At the same time, the proportion of labor force engaged in agriculture was reduced from 90% to 25%, and more people were engaged in other important jobs, which promoted the great division of labor in social production, promoted the development of industry and tertiary industry, and promoted the national economic prosperity.

## The Situation of Agricultural Mechanization

Since 1970, China has seen a remarkable development in agricultural mechanization, which has been playing a very important role in promoting the progress of modern agriculture, ensuring agro-product supply, guaranteeing food safety, increasing competitive ability of agro-product and raising farmers' income, and also supporting the rapid growth of national economy. It will be presented in five aspects as follows.

### The Ownership of Agricultural Machinery Has Increased Rapidly

By the end of 2019, the original value of farm machinery reached CNY 940 billion, averaging CNY 5,112 per peasant household, making up 63.8% of the fixed assets of agricultural production for them. The total power of farm machinery had reached 1,028.4 million kW, which increased by 75 times compared with that of 1970 of 13.7 million kW. Since 2004, China has successively introduced a series of agricultural machinery policies which promoted the rapid development of agricultural machinery. Since 2005, China's total power of agricultural machinery has increased by nearly 2

**Table 2** China agricultural labor productivity from 2000 to 2019

Years	Agricultural labor productivity (yuan)	Years	Agricultural labor productivity (yuan)
2000	4,083.29	2010	13,759.19
2001	4,259.05	2011	16,838.91
2002	4,418.72	2012	19,044.93
2003	4,687.38	2013	21,938.73
2004	6,001.81	2014	24,408.21
2005	6,520.75	2015	26,358.23
2006	7,300.02	2016	27,976.93
2007	9,005.27	2017	29,650.26
2008	10,849.21	2018	31,954.78
2009	11,624.71	2019	36,238.72

Source: *China Statistics Yearbook*.

**Table 3** Changes in China's total grain output in 1970-2019

Years	Total grain output (million tons)	Annual Increment (million tons)	Annual Growth rate (%)
1970	239.96	-	-
1975	284.52	44.56	18.57
1980	320.56	36.04	12.67
1985	379.11	58.55	18.26
1990	446.24	67.13	17.71
1995	466.62	20.38	4.57
2000	462.18	-4.44	-0.95
2005	484.02	21.84	4.73
2010	546.48	62.46	12.90
2015	621.44	74.96	13.72
2019	663.84	42.40	6.82

Source: *China Statistics Yearbook*.

million kW every five years (**Table 4**). The average power availability per hectare now stands at 6.6 kW in 2019. Some agricultural machinery including farm tractors, seeders, rice transplanters, power spray (powder) machine, Drainage and irrigation machinery, grain combine harvesters and grain dryers, increased quickly and reached 22.24 million, 5.41 million, 0.91 million, 6.21 million, 22.89 million, 2.13 million and 0.13 million units respectively (**Table 5**). The matching implement ratios for farm tractors is 1:1.8.

### The Mechanized Operation Level Is Heightened Steadily and the Service Field of Agricultural Machinery Is Spread Gradually

By the end of 2019, China's comprehensive level of tilling, planting and harvesting mechanization reached 70.02%, 10 times that of 1970. The mechanization percentages of tillage, planting and harvesting reached 85.22%, 57.30%, and 62.46% respectively (**Table 6**). Wheat, corn and rice are basically mechanized in the whole process of field production. The mechanization level of rice planting was slightly lower at 53.89% in 2019. The mechanization level of potato sowing and harvesting, rape sowing and harvesting, peanut sowing and

harvesting, cotton harvesting are also relatively low (**Table 7**). The mechanization level of sugarcane harvesting is only about 2%. There are 27 provinces, municipalities or autonomous regions with integrated mechanized levels of over 50%, and 13 of them are over 70% (China has 31 provinces, autonomous regions and municipalities directly under the Central Government). The total area of greenhouses is about 19 billion m<sup>2</sup> all over China. At present, the field of agricultural mechanization has expanded from grain crops to cash crops, from field agriculture to facility agriculture, from crop

farming to livestock breeding, aquaculture and agro-product processing, from field production to before-production and post-harvest extension.

### Remarkable Science and Technology Innovations in Agricultural Mechanization

In recent years, there has been a marked progress in technological innovation, which provides a great technical support to increase mechanization levels. For example, in view of key links for main crops' production, the technology and equipment for mechanized rice pro-

**Table 4** Changes of total power of agricultural machinery in China in 1970-2019

Years	Total power of agricultural machinery (million kW)	Annual increment (million kW)	Annual growth rate (%)
1970	13.7	-	-
1975	36.5	22.8	166.42
1980	145.6	109.1	298.90
1985	208.5	62.9	43.20
1990	283.8	75.3	36.12
1995	346.9	63.1	22.23
2000	429.1	82.2	23.70
2005	526.5	97.4	22.70
2010	719.8	193.3	36.71
2015	902.3	182.5	25.35
2019	1,028.4	126.1	13.98

Source: *Statistical Yearbook of China Agricultural Mechanization (1970-2019)*. Agricultural Mechanization Management Department, Ministry of Agriculture and Rural Affairs, PRC

Note: The data of total power of farm machinery does not include the power of farm transporter.

**Table 5** The Numbers of some agricultural machinery in China from 1970 to 2019 (million sets)

Years	Tractors	Seeders	Rice transplanters	Power spray (powder) machine	Drainage and irrigation machinery	Grain harvesters	Grain dryers
1970	0.20	0.00	0.00	0.00	1.47	0.00	0.00
1975	0.94	0.00	0.03	0.11	3.89	0.01	0.02
1980	2.62	0.19	0.08	0.28	5.91	0.03	0.00
1985	4.67	0.14	0.01	0.31	6.16	0.04	0.00
1990	7.79	0.69	0.02	0.45	8.48	0.04	0.00
1995	9.30	1.21	0.02	1.08	10.29	0.08	0.01
2000	13.74	2.44	0.04	1.66	14.83	0.27	0.01
2005	16.79	3.65	0.08	2.39	17.53	0.48	0.04
2010	21.78	5.38	0.33	4.64	21.59	0.99	0.07
2015	23.10	6.40	0.73	6.19	23.16	1.74	0.12
2019	22.24	5.40	0.91	6.21	22.89	2.13	0.13

Source: *Statistical Yearbook of China Agricultural Mechanization (1970-2019)*. Agricultural Mechanization Management Department, Ministry of Agriculture and Rural Affairs, PRC



duction such as transplanting and harvesting and the harvesting machinery for corn has become more mature and brought into big area extension. In addition, there has been a large progress in the fields of conservation tillage, straw crushing and re-utilization, pasture production and processing, sufficient and safe chemical application, planting and harvesting for main industrial crops as cotton, rape, peanut and potato. Along with the agricultural structure adjustment and implementation of *The Plan of Area Distribution for Superior Agro-Product*, local governments are incentivized to

develop the agricultural mechanization depending on the regional contexts and characteristics, research and disseminate mechanization technologies for local special agro-products, to meet the demand of agriculture production and promote the development of agriculture and rural economy.

### The Level of Socialized Service of Agricultural Machinery Increased Significantly

Agricultural machinery has become the main means for farmers to deal with agricultural production and increase income. Innovative ag-

ricultural machinery service organizations, such as agricultural machinery cooperatives, associations and farm machinery leading households, are emerging. By the end of 2019, there were 192,173 service organizations and 40.7 million households providing mechanized farming service with 53.4 million practitioners. Agricultural machinery operation service gross income in China reached CNY353.5 billion. Since 1996, relevant ministries and agencies in China had jointly launched the so-called Cross-regional Wheat Harvesting Program using combine harvesters, which has sped up the process of market-orientation, specialization and socialization. Cross-regional harvesting service is now covering not only wheat, but also rice, corn, soybean and potato, with much wider scope and larger areas all over the country. The socialized service of agricultural machinery has realized the common utilization of agricultural machinery, improved the utilization efficiency of agricultural machinery, effectively linked small farmers with modern agricultural production, and set out a road of agricultural mechanization with Chinese characteristics.

### The Laws, Regulations and Policies System for Agricultural Mechanization Is Sufficient

The tenth meeting of the Standing Committee of the tenth National People's Congress examined and approved *The Law on Promoting Agricultural Mechanization of the People's Republic of China*, which was put into effect on November 1, 2004. It is the first law on promoting agricultural mechanization in China, and it further defined the promotion function of governments at all levels in agricultural mechanization. It also provided the ground for supporting policies to research & development of agricultural machinery, to the system of quality guarantee and service of agricultural machinery, to the application of advanced technology and

**Table 6** The comprehensive level of tilling, planting and harvesting mechanization of China in 1970-2019 (%)

Years	Tillage mechanization level	Planting mechanization level	Harvesting mechanization level	The comprehensive level of tilling, planting and harvesting mechanization
1970	18.00	0	0	7.20
1975	33.29	5.20	1.50	15.33
1980	42.40	10.90	3.10	21.16
1985	51.00	15.00	7.00	27.00
1990	56.32	20.04	11.15	31.89
1995	47.75	25.75	18.26	32.30
2000	50.15	30.26	22.63	35.93
2005	69.61	43.04	38.41	52.28
2010	80.43	52.08	53.40	63.82
2015	84.03	56.93	61.39	69.10
2019	85.22	57.30	62.46	70.02

Source: *Statistical Yearbook of China Agricultural Mechanization (1970-2019)*.

Agricultural Mechanization Management Department, Ministry of Agriculture and Rural Affairs, PRC

**Table 7** Main crop production mechanization level in 2019 (%)

	Tillage mechanization level	Planting mechanization level	Harvesting mechanization level	The comprehensive level of tilling, planting and harvesting
Crop	85.22	57.30	62.46	70.02
Wheat	99.81	90.88	96.29	96.36
Corn	97.77	88.81	77.32	88.95
Rice	98.84	53.89	93.43	83.73
Potato	74.68	27.80	27.78	46.55
Soybeans	88.21	86.55	80.89	85.52
Rape	84.80	32.54	44.00	56.88
Peanut	77.36	52.91	46.05	60.63
Cotton	99.34	88.04	50.13	81.18

Source: *Statistical Yearbook of China Agricultural Mechanization (1970-2019)*.

Agricultural Mechanization Management Department, Ministry of Agriculture and Rural Affairs, PRC

equipment for farmers and organizations. It launched measure to subsidize and provide financial service for farmers and service providers to purchase machines and equipment, to design and apply policies on preferential tax, fuel subsidies and so on. This law further improved the development environment for agricultural mechanization with combination of government instruction and market-oriented system under the legal frame. It exerts an active and great influence on the cause of agricultural mechanization while encouraging farmers to purchase and use farm machinery and raise productivity. The State Council of China promulgated and implemented *The Regulations on the Safety Supervision and Administration of Agricultural Machinery* in 2009, *Opinions on Promoting Sound and Rapid Development of Agricultural Mechanization and Agricultural Machinery Industry* in 2010, and *Guidelines on Accelerating the Transformation and Upgrading of Agricultural Mechanization and Agricultural Machinery and Equipment Industries* in 2018. It marks the continuous improvement of laws, regulations and policy system of agricultural mechanization and agricultural machinery equipment industry.

### **International Exchange and Cooperation Has Been Strengthened**

In recent years, China's large market volume has aroused the attention of large international manufacturers of agricultural machinery. They have cooperated with the Chinese relevant departments and enterprises to exploit the market and have also won the market share. In order to encourage the imports of large-size agricultural machinery, Chinese government has promulgated the preferential import tax policies, Imports of agricultural machinery and tools enjoy government financial subsidies. China's agricultural machinery research institutes, colleges & universities and enterprises

are actively strengthening technical innovation and cooperation so as to improve product quality by introducing the foreign advanced experiences and technologies.

### **The Development Environment of Agricultural Mechanization**

Both national and rural economy has been keeping a constant, stable and rapid development in China. The increased investment in agriculture and rural economy has brought new opportunities for the development of agricultural mechanization, especially when Chinese government pays great attention to food security and farmers' income.

#### **The Economic Environment**

The national economic strength is the economic base for development of agricultural mechanization. In 2019, China per capita GDP reached CNY 70,892 (US\$10,127), China's urbanization rate has exceeded 60%, and the total amount of tax revenue over CNY15,800 billion. Overall, China has entered the mid-term stage of industrialization when the industry finances agriculture and the city promotes the development of the countryside.

The economic growth in cities and towns has created new conditions for the development of agricultural mechanization. Along with the progress of China's industrialization and modernization, there must be an inexorable trend, in which city brings country into town, rural labor force is transferring to non-agricultural industries and urban rapidly. The rural migrant labor to business has more than 263 million, 60% of them are under 40 years old. A present, there exists the limited supply of labor force in some developed areas with a big problem of the old aged and large contradiction between the operating labors and farming seasons. Nearly one-third

of agricultural labor force are more than 50 years old. Thus it's more urgent to use machinery instead of labor in agricultural production and should change the traditional production method to heighten agricultural productivity greatly by using machinery instead of handwork. Therefore, it will provide new conditions for the development of agricultural mechanization in term of the rural economic progress, the improvement of living quality in country and big transfer of rural labor force.

The establishment of modern agriculture has put forward new demands for agricultural mechanization. China has currently entered a new stage of development in modern agriculture with the change from tradition to modern style. The practice has proved that it is favorable for the progress of agricultural mechanization to enhance scientific and technical standards, to reduce production cost with higher efficiency, to increase output ratio of farmland and productivity and to heighten the integrated production capacity. In addition, some new mechanized technologies, including conservation tillage and straw utilization, can save resource, protect environment and keep sustainable agriculture development. In a word, it is an inevitable choice to realize agricultural mechanization for agricultural modernization.

#### **The Policy Environment**

Chinese government is paying greatest attention to agriculture, rural areas and farmers, and it promulgated a series of policies to support agriculture production and increase farmers' income sustainably. For example, Chinese central government issued *The Law on Promoting Agricultural Mechanization of the People's Republic of China* in June 2004, which has brought the development of agricultural mechanization into the legally enabled course.

In recent years, both national and

local governments in China have adopted a series of measures, such as regional laws and regulations issued by 31 provinces, municipalities or autonomous regions, to support and promote the development of agricultural mechanization. Since 2000, the Chinese government has invested a total of CNY220.5 billion in subsidies for the purchase of agricultural machinery. This is sometimes supplemented by additional subsidy regimes and incentives at local levels. The measure of subsidy has greatly aroused farmers' and agricultural production organizations' enthusiasm for purchase and use of farm machinery, hence accelerating the popularization and use of new equipment and technology.

In 2015, the Ministry of Agriculture of PRC promulgated and implemented *The Opinions on Promoting Whole-Process Mechanization in The Production of Major Crops*. By the end of 2019, there had been 453 demonstration counties for whole-process mechanized crop production.

In 2017, the Ministry of Agriculture, the National Development and Reform Commission and the Ministry of Finance of PRC jointly issued *The Guiding Opinions on Accelerating the Development of Agricultural Producer Services*. China will vigorously promote the development of agricultural producer Services, especially the development of socialized services for agriculture and

agricultural machinery.

### The Technological Environment

There are over 8,000 agricultural machinery manufacturers in China, with over 2,000 scale-size enterprises with annual revenue of over CNY 20 million. Chinese enterprises can manufacture about 4,000 kinds of agricultural machinery under 1517 small-types, 120 big-types and 12 categories. The annual farm machinery gross industrial output value ranked the third place in manufacturing sectors in China, only after automobile and electrical engineering and equipment. This has also laid a proper foundation for the development of agricultural mechanization. China has become a global manufacturing power of agricultural machinery.

A relatively comprehensive network of management and service of agricultural machinery has come into being. The system consists of various departments and institutions of research, testing and evaluating, extension and training at different levels. There were 67 research institutions and 62 testing and certification bodies over municipal level, 2,519 extension stations and 1,567 technical training schools over county level in 2017. Surrounding the service to larger agriculture and the development to larger agricultural machinery, China has set up the platform and demonstration base of technological innovation

suitable for agricultural production, and coordinated and facilitated efforts on the research and production of new agricultural machinery and matching implements with marked achievements and transformed capability.

### The Development Trend of Agricultural Mechanization

Agricultural mechanization should provide technological support for the improvement of resources utilization ratio and laboring productivity in term of the global process of international economy and the change of opportunity cost of labor force. The priorities of future agricultural mechanization will be placed at developing resource- and labor-saving technologies, shifting focus from production to higher efficiency, as well as from single technologies to integrated technologies, and trend to intelligent agriculture, intelligent agricultural machinery development. The role of agriculture will become much more significant to national economy for it to keep high growth rate. The development trend of agricultural mechanization in China can be summarized in four aspects.

#### The Different Development Patterns of Agricultural Mechanization Will Come into Being with the Closer Combination between Mechanization and Industrialization for Production of Main Agro-products

The key task in agriculture and rural economy is to push the strategic structure adjustment at present. China will fully implement *The Plan of Area Distribution for Superior Agro-Product and The national agricultural modernization plan (2016-2020)* to establish the industrial zones of superior agro-products. Agricultural mechanization should provide technical support for industrial development of local superior

**Fig. 1** China central government fund for agricultural machinery purchase subsidies

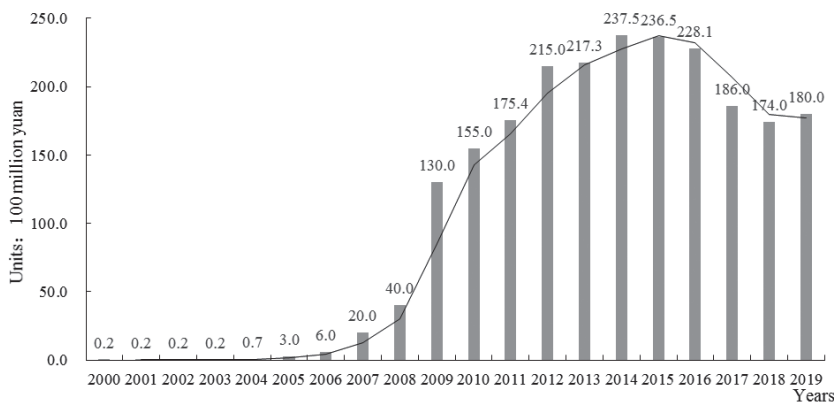

agricultural areas in accordance with the demand of structure adjustment of agriculture and rural economy so as to improve the international competition. For example, the focus will be put on the mechanization of production, processing and storage of main agro-products on the base of increased mechanization level for the coastal developed areas in East China. In the main production areas of grain, efforts will be focused on increasing the mechanization level of wheat production, further developing mechanization strategy and technology for paddy, corn and potato crops, and providing comprehensive service from before-production to post-harvest. Meanwhile the country will gradually advance mechanization of grain production, and also promote mechanization of pasture and industrial crops as sugar material and cotton, and agro-product processing in West China. The above-mentioned technologies of agricultural mechanization, including for industrial crops, facility agriculture, animal farming and agro-product processing will be the new champions. The development pattern of agricultural mechanization will be characterized by regional diversification, high efficiency and better quality.

#### **Sustainable Agricultural Mechanization Technologies Will Be the Priority**

China will carry out the strategy of sustainable development to enhance rational utilization and efficient protection of resources of farmland, water and fertilizer, to improve agricultural ecological environments, to protect agricultural environment from pollution, to promote agricultural transformation from resource intensiveness to sustainability. The key points will be put into the development of advanced and applicable mechanized technologies for the protection of ecological environments and sustainable development. Therefore,

China will give priority to the development of technologies mainly including conservation tillage, water-saving irrigation, integrated utilization of agricultural waste materials, intensive farming engineering, grassland improvement and construction of man-made pasture, integrated prevention and control of biological disaster, infrastructure facilities construction, agricultural aviation and so on.

#### **The Capacity of Agricultural Machinery Socialized Service and the System of Laws & Regulations of Agricultural Mechanization Will Be Further Improved**

The basic development trend of agricultural mechanization is noted for the foundation and improvement of fair and standard market system of agricultural machinery product and service, the promotion of market-orient and industrialization of agricultural machinery service, the wider spread of socialization service and higher increasing of service level. China will further strengthen and improve the development of the related laws & regulations, the standards of agricultural mechanization, the quality control system of agricultural machinery and the information system of agricultural mechanization so as to provide the legal and technical support for the sound development of agricultural mechanization.

#### **The Process of Technical Innovation and Upgrading and Updating of Agricultural Machinery Product Will Be Accelerated**

Along with popularization and extension of modern scientific technology such as advanced manufacturing, mechanical and electrical integration, intelligentization and information, the agricultural machinery industry will quicken the pace of technical innovation and product modification; greatly improve the performance and quality of agricultural equipment, which is beneficial

to reduce the difference of agricultural mechanization between China and foreign advanced countries. This will also be conducive to increased international competitiveness for China's agricultural machinery.

## **Conclusions**

China is a large agricultural country and its agriculture is strongly connected with agricultural mechanization. Agricultural mechanization can improve agricultural labor productivity and the farmland ecological environment. China government will increase the support for agricultural mechanization, encourage context-specific development models in different regions, support the application and popularization of agricultural mechanization technologies of energy saving and environmental protection, improve land management, support the development of agricultural cooperatives and family farms so as to reduce costs and improve benefits of mechanized systems.

■ ■

# Current Status and Prospects of Agricultural Mechanization in China



by  
 Zhao Yanshui  
 Doctor, Professor  
 Vice President of Sinomach Academy of  
 Science and Technology Co., Ltd  
 A2.Taiping St.,Xicheng District, Beijing  
 CHINA  
 zhaoy63@163.com

## Introduction

Agricultural mechanization is an important symbol of modern agriculture, it plays an important role in “eradicating hunger, achieving food security, improving nutrition and promoting sustainable agriculture”, it is also an important support for China to implement its rural revitalization strategy. As an agricultural country with a large population, China has implemented a rural revitalization strategy and promoted the modernization of agriculture and rural areas. At the same time, China has promoted the all-round, high-quality and efficient development of agricultural mechanization, all of these are of great significance for promoting the Sustainable Development Goals of the United Nations.

## Current Situation of Agricultural Mechanization in China

The scale of the industry continues to grow. From 2016 to 2020, the average growth rate of business income of China’s agricultural machinery industry is 3.22%, China’s agricultural machinery industry has entered a new stage of structural adjustment, shifting from high-speed growth to high-quality develop-

ment, and the scale of the industry has further increased. In 2019, the comprehensive mechanization rate of crop cultivation and harvest in China reached 70%, basically realizing mechanized production. In 2019, there were 1,730 agricultural machinery manufacturers in China, its main business revenue reached 230.6 billion yuan, it accounts for about 30% of the global agricultural machinery market, and it is the country with the largest agricultural machinery production and sales in the world.

The equipment system for the whole operation of major grain crops has been basically established. At present, the variety and quantity of production can basically meet the market demand. The development of China’s agricultural equipment technology has moved from the mechanization stage where machinery replaces human and animal power, through the realization of automation based on electronic control technology and entered the intelligent stage with information technology as the core. In terms of cutting-edge and key core technologies such as automation, informatization, and intelligence, we have made breakthroughs in key technologies such as high horse power, compound soil preparation, variable fertilization, precision seeding, and efficient har-

vesting. It has formed a complete set of grain operation equipment that adapts to different production scales, and the technology is extended to be applied to cotton, sugarcane, peanut, potato and other cash crops. The advanced agricultural machinery such as 200-horsepower tractors, automatic driving technology, power-shift tractors, sugarcane harvesters, cotton pickers, and digital dispatch management platforms have gradually begun to be industrialized.

Actively explore the “Chinese model” of agricultural services. Based on China’s current land policy and rural status quo, actively explore new agricultural operation and service modes, and develop the application of complete solutions of advanced agricultural equipment in the field of whole-process mechanization, which effectively solve the problems of insufficient, unbalanced, and incomplete agricultural equipment and farmland operations, while promoting the integrated development of traditional agriculture and secondary and tertiary industries. At present, China has cultivated a total of 192,000 agricultural machinery service organizations of various types, among them, 74,400 professional cooperatives have a service area of 794 million mu. Various localities are actively developing operational service mod-

els such as agricultural machinery + land cooperatives, whole-process mechanization + comprehensive agricultural services, land trusteeship and other operational service models, the national trusteeship operation service area is 95.82 million mu. The development of agricultural mechanization and the exploration of new agricultural service models have effectively improved China's agricultural productivity, promoted the integrated development of urban and rural areas, and promoted China's modernization process.

## Industrial Problems and Challenges

After years of development, China has become the world's largest producer and user of agricultural machinery, however, it is affected by factors such as complex geographic and climatic environment, diverse demand for agricultural machinery products, and large differences in the operating environment of machinery and tools, the problem of unbalanced and insufficient development of agricultural mechanization and agricultural machinery equipment industry is still prominent.

Firstly, the ability of technological innovation needs to be enhanced. Applied basic research is weak, basic principles, basic data, and basic methods are not systematic enough, and there are few original technological innovations from mechanisms, principles, methods, technologies, devices and products. The key core technology level is not high, agricultural equipment still lags behind the international leading level in terms of operational efficiency, navigation and positioning control and loss control, water and fertilizer application control, and overall machine quality and reliability.

The second is the structural contradictions of industry are relatively prominent. At present, there are few enterprises above designated size in

China, and the industry is relatively fragmented and concentrated, agricultural machinery products are mainly concentrated in traditional products such as power machinery and food production machinery. The R&D and production capacity of characteristic cash crops, primary processing of agricultural products, facility agricultural machinery, and animal husbandry machinery is relatively weak.

The third is the integration of agricultural machinery and agronomy is not enough. The integration of agricultural machinery and agronomy, and the integration of agricultural machinery informatization are insufficient, which affects the efficiency of agricultural machinery operation and the efficiency of agricultural machinery, weak links, regions and agricultural mechanization of crops are low.

In addition, the characteristics of China's aging and the migration of agricultural population to cities are obvious, it is urgent to cultivate new types of professional farmers, which brings new opportunities and challenges to agricultural mechanization.

## Prospect of Agricultural Mechanization Development in China

Nowadays, under the background of land circulation and agricultural structure adjustment, China's agricultural machinery industry is evolving towards diversified, intelligent, efficient, energy-saving, and environmentally friendly products, and has embarked on a path of agricultural mechanization and intelligent development with Chinese characteristics. By 2025, it is estimated that the comprehensive mechanization rate of farming and harvesting of major crops in China will reach over 75%, and the overall mechanization rate of animal husbandry will reach over 50%.

The agricultural machinery equipment category is complete, and the technical level of the equipment required for the mechanization of food crop production has been greatly improved. The equipment needed for the mechanization of the production of major cash crops is effectively supplied, the equipment required for mechanization in the fields of animal husbandry, aquaculture, agricultural products processing industry, and mountainous and hilly areas are basically met.

In addition, with the development of smart agriculture, the mode of agriculture will shift from an undifferentiated fixed rate operation mode to a precise operation mode, from the entire farmland receiving the same level of resource input to high-precision customization, so that each crop can receive the accurate resources needed for growth. And on that basis, cognitive computing and machine intelligence will become the main development direction of agricultural machinery by constructing state perception - real-time analysis - autonomous decision - accurate execution - learning and improvement in the scene.

Agricultural machinery will be further deeply integrated with modern information and communication technology, satellite navigation technology, electronic control technology and artificial intelligence, entering a new stage of integration of "mechanics, control, communication, and computing". The development of new technology will bring about changes in the ecological chain and value chain of the agricultural machinery industry, and further promote the specialized division of labor in the industry, accelerate the development of design, manufacturing, service, etc. in the form of independent existence; at the same time, the agricultural machinery industry will be given new features of flexibility, customization, and low carbon based on scale, standardization, and automation.

## Conclusions

In 2020, due to the superposition of multiple factors such as the COVID-19 epidemic, locust plagues and extreme climates, global food security are facing a huge challenge. Global agriculture needs to adopt more efficient, low-consumption

smart equipment and large-scale agricultural production to improve agricultural production efficiency and agricultural resource utilization efficiency, establish a more sustainable agricultural production system. In the current and future period, China will continue to implement innovation-driven and rural revital-

ization strategies, promote agricultural mechanization to accelerate the realization of full-scale, high-quality and efficient development, and help achieve the Sustainable Development Goals of the United Nations. ■■

*(Continued from page 105)*

## Smart Farm Mechanization for Sustainable Indian Agriculture

- Chaturvedi, V., Hejazi, M., Edmonds, J., Clarke, L., Kyle, P., Davies, E. and Wise, M. 2013. Climate mitigation policy implications for global irrigation water demand. *Mitigation and Adaptation Strategies for Global Change*, 20(3), 389-407.
- DARE-ICAR Annual Report 2018-19, 2019. *Agricultural Research Data Book*. Department of agriculture, cooperation and farmers welfare, Government of India. 220 p. <https://krishi.icar.gov.in/AgResDataBook.jsp>
- FICCI. 2019. Farm mechanisation: Ensuring a sustainable rise in farm productivity and income, 1-56. [http://ficci.in/spdocument/23154/Online\\_Farm-mechanization-ficci.pdf](http://ficci.in/spdocument/23154/Online_Farm-mechanization-ficci.pdf)
- Garg, V. 2018. India: Vast Potential in Solar-Powered Irrigation. Institute for the energy economics and financial analysis. 9 pp. <https://ieefa.org/wp-content/uploads/2018/08/Indias-Vast-Potential-in-Solar-Powered-Irrigation-.pdf>
- Kapur, R., Gulati, S. and Chauhan, S. 2016. Accelerating growth of Indian agriculture: Micro irrigation an efficient solution Strategy paper - Future prospects of micro irrigation in India. 84 p.
- Kapur, R., Chouhan, S., Gulati, S. and Saxena, V. 2015. Transforming agriculture through mechanisation. A knowledge paper on Indian farm equipment sector, 56 p.
- Kurmanath, K. V. 2019. Intelligent spraying drone to help farmers target specific crop areas in Telangana, AP. *Agri Business*. <https://www.thehindubusinessline.com/economy/agri-business/a-drone-startup-that-helps-farmers-target-fertiliser-sprays-only-on-specific-crop-areas/article29811910.ece>
- Madramootoo, C. A. and J. Morrison. 2013. Advances and challenges with micro-irrigation. *Irrigation and Drainage*, 62(3), 255-261.
- Mehta, C. R. 2015. Research Highlight. 2015 of All India Coordinated Research Project on Farm Implements and Machinery. Technical Bulletin No. CIAE/FIM/2015/179, 83 pp.
- Mehta, C. R., Chandel, N. S., Jena, P. C. and Jha, A. 2019. Indian agriculture counting on farm mechanization. *Agricultural Mechanization in Asia, Africa and Latin America*, 50(1), 84-89.
- Mehta, C. R., Chandel, N. S., T. Senthilkumar, T. and Singh, K. K. 2014. Trends of Agricultural Mechanization in India. *CSAM Policy Brief*, 2, 1-13.
- Microsoft News Center India. 2017. Digital Agriculture: Farmers in India are using AI to increase crop yields. <https://news.microsoft.com/en-in/features/ai-agriculture-icrisat-upl-india/>
- NITI. 2018. Demand & supply projections towards 2033 crops, livestock, fisheries and agricultural inputs. The Working Group Report. <https://niti.gov.in/sites/default/files/2019-07/WG-Report-issued-for-printing.pdf>
- Smilovic, M., Gleeson, T. and Siebert, S. 2015. The limits of increasing food production with irrigation in India. *Food Security*, 7(4), 835-856.
- World Bank Indicators. 2013. CIA fact book, Mechanisation and Farm Technology Division of Department of Agriculture and Cooperation, Trading Economics, *FAO Year book 2013*. ■■

# SDGs and Agricultural Mechanization in India



by  
 Indra Mani  
 Head, AE Division,  
 ICAR-Indian Agricultural Research Institute  
 President, Indian Society of Agricultural Engineers,  
 New Delhi  
 INDIA

Poverty and hunger are the two main challenges still faced globally. There have been technology led inclusive developments in India like in many other parts of the world. From 50 million tons of food grain production annually in 1950 to the present 294 million tons annually have brought India in a very comfortable situation in terms of not only food security but also nutritionally too. India's annual horticultural production has surpassed 300 million tons mark. However, due to different social and economic reasons, nutritive diet to all is still remains a challenge. Agriculture is main stay of India's economy particularly in pandemic like situation as faced today in form of Covid -19. Also, Indian agriculture faces a bigger threat than ever before due to degradation of natural resources, especially land and water. It becomes important to combat these threats, but without compromising on economic development. This requires a new set of farm policies, technologies, and institutional reforms.

Sustainable development is a key to peace, progress and prosperity of Indian people. Collective effort and inclusive growth is great vision of our Prime Minister Mr. Narendra Modi. Therefore, the sustainable development goals are the pathways for development of India in 21st century. In 2015, global

leaders joined hands to chart their progress and evaluate where they stood with regard to the Millennium Development Goals (MDGs). It was a unique joint effort by leaders of different countries on combating poverty, hunger, undernourishment, and other global issues. It is a matter of satisfaction that like most of the developing countries, India has made significant efforts to achieve various goals. In fact, there have been sustainable efforts to improve the economy of developing world through different international development programs as a result they could reduce poverty by half between 1990 and 2010, although the decline in poverty level was uneven across countries. In 1990-1992, the number of poor people in Asia was about 740 million, which declined to 565 million in 2010-2012. Within Asia, the largest concentration is in south Asia and India also faces a grim situation in this regard as it has the largest poor and food-insecure population in South Asia. As global collective efforts, more countries adopted a post-2015 agenda, which included a renewed set of goals to end poverty, protect the planet, and ensure prosperity for all as part of the new Sustainable Development Goals (SDGs). The resolution adopted by the United Nations (UN) has a broader inter-governmental agreement, which while acting as the new

agenda, builds on the Resolution, popularly known as "The Future We Want". There are 17 aspirational "Global Goals", with 169 targets under SDGs. Among these, the goals having direct relevance to agriculture are: 'No Poverty', 'Zero Hunger', and 'Climate Action', besides the one related to 'Life on Land'.

In India, agriculture is the major provider of livelihood to the poor, especially in the rural areas. However, the agricultural sector is facing big challenges like declining size of landholdings, deteriorating natural resources (especially soil and water), adverse impact of climate change, declining factor productivity, rising input costs, fluctuating markets, and declining farm income. All these factors make agriculture a riskier means of livelihood. The issues those arise are to make agriculture a contributor towards achieving SDGs, the strategy to promote agriculture for achieving SDGs in addition to sharing international experiences. As a major policy change to make agricultural economy a safe enterprise and help doubling farmers income, India has planned to enact three major farm bills related to agricultural market reforms, contract farming provisions and amending essential commodities act. These bills will do away with middlemen and other impediments



in the growth of farmers. Adoption of better management practices; in addition to developing high yielding crop varieties have immense potential in achieving the SDGs. It is encouraging that the National Agricultural Research System (NARS) has developed several technologies that promise to increase incomes, reduce production cost, conserve natural resources, improve food quality and nutrition, and minimize various kinds of risks. The need is to create an enabling environment to scale-out useful and efficient technologies/innovations for wider adoption and large-scale impact on production and income of small-holder farmers. The Government of India gives high priority to the agricultural sector and plans to make it more efficient, competitive, sustainable, and resilient. 'Doubling Farmers' Income by 2022' is the latest policy initiative of the government. The other programs that aim to increase farmers' income, conserve soil and water resources, improve resilience, and reduce risks includes are Prime Minister's Irrigation Program, Prime Minister's Agricultural Insurance Scheme, National Food Security Mission, National Horticulture Mission, National Mission on Sustainable Agriculture, National Agricultural Development Plans, and National Livestock Mission. There are initiatives to connect farmers with remunerative markets through e-NAM (One Nation One Market) and consolidate farmers to derive benefits of economies-of-scale through Farmer Producer Organizations/Companies. All these efforts demonstrate India's commitment to accomplish the SDGs related to agriculture. There is, however, an urgent need to ensure reorientation of on-going efforts toward higher efficiency and effectiveness of various initiatives by developing a road map by which to achieve the goals well before 2030. Mechanization is key to agricultural growth in India. The number of agricultural

workers is showing a declining trend and is projected to reduce to 202 million by 2050 from 263 million in 2010-2011. The shortage of agricultural workers is triggering farm mechanization in the country. The adoption of farm mechanization can ensure improved input-use efficiency, enhanced cropping intensity, reduced cost of production, and less drudgery for agricultural workers, especially women. An overview of the different farm equipment being used in India across the agricultural value chain, from land preparation to harvesting, reveal accelerated developments in farm mechanization. Though, total power availability on Indian farms has increased from 0.293 to 1.841 kW/ha at a CAGR of 4.58% during the last forty one years, overall mechanization level in India is only 40-45%. The concerted efforts have resulted in the mechanization of critical farm operations of major crops in different states. In order to lay special emphasis on farm mechanization and to bring more inclusiveness, a dedicated Sub-Mission on Agricultural Mechanization (SMAM) was launched. SMAM puts 'Small & Marginal Farmers' at the core of the interventions with a special emphasis on 'reaching the unreached', i.e. bringing farm mechanization to those villages where the technologies deployed are decades old. Besides, the mission is also catering to 'adverse economies of scale' by promoting 'Custom Hiring Services' through 'the rural entrepreneurship' model. The government intends to go beyond food security and give back a sense of income security to our farmers. To make the cost of machinery affordable to all the farmers, Govt. has launched a credit-linked subsidy scheme. It is envisaged that with policy support on farm mechanization the farmers' income will be doubled by 2022. ICAR has been giving emphasis on development and adoption of new and cutting edge sensor based preci-

sion engineering solutions like variable rate applicator, IoT, robotics, drone enabled technologies, big data analytics and block chain technology. Some successful experiences are zero till drill and its variants, strip till drill, roto till drill and slit till drill, providing saving of 40-70 percent in time and 50-70 percent in fuel. Happy Turbo seeder is suitable for sowing under heavy residue condition and is helpful in paddy residue management which is very common in northern states of India. In addition, it provides savings of 78 % in time, 68 % in fuel, 77 % labor, and 72 % in cost of operation. Another success was development of multi-purpose equipment for sugarcane, which is a tractor-operated implement, used for planting of sugarcane setts (0.2 ha/hour), facilitating inter-culture (0.8 ha/hour), and earthing up operations (0.4 ha/hour). Also, variable rate urea applicator, which can apply urea @ 18.5-65.0 kg/ha and requires an android smart phone with GPS for operation is very useful. Commercially available harvesting and threshing equipment, including a tractor-operated reaper binder, flail type fodder harvester-cum-chaffer, tractor-mounted root crop harvester cum-elevator, and self-propelled rice combine are very much in use on Indian farms. Development of proven technologies like Pusa rapid composting technology, Pusa turner cum mixer, Pusa compost sieving machine, Pusa Aqua-ferti-seed drill, liquid fertilizer (UAN) application system, paddy straw collector cum chopper and powered integral equipment for small farm mechanization have created a great socio-economic impact by making agriculture a profitable venture through production in dry land areas, enhanced fertilizer use efficiency, biomass management, production of quality compost and mechanization of small farms.

To promote farm mechanization, there is critical need for public-

private partnership both for research and development. In future, agriculture will be dominated by precision and conservation agriculture. Therefore, there is a need to develop equipment that is suitable for small landholdings and horticultural crops in hilly areas, and cost-effective technologies like smart tractors, unmanned aerial vehicles and wireless technology. In India research and development efforts and approaches in agricultural machinery have been directed towards finding cost-effective solutions to location-specific problems of agriculture. National Agricultural Research System (NARS) comprising of Indian Council of Agricultural Research (ICAR), New Delhi and State Agricultural Universities primarily looks after the need of research and development activities, need based region specific technologies and specific-problem related issues. Some of the research institutes under the aegis of Central Scientific Industrial Research (CSIR), New Delhi are also engaged in research and development of agricultural machinery. The Agricultural Engineering institutions are collaborating with IITs, CSIO and other institute of eminence for developing engineering solutions for the emergent problems in Indian agriculture. The ICAR-Indian Agricultural Research Institute has played a pivotal role in bringing all the stake holders in a single platform to chalk out the action plans for the future engineering needs in agriculture. The start-ups are promoted for agricultural engineering innovations through hand holding. On the basis of the recommendations of brain storming session organized by the Indian Society of Agricultural Engineers at NASC, the Department of Science and Technology invited research proposals on Agro-Tech specific to engineering solution to agriculture. The Indian Society of Agricultural Engineers even in the lockdown situation due to COVID-19 pandemic

conducted webinars for training of the students and faculties and also for farmer's, FPOs. The COVID situation has closed down many industries and affected very badly the service sector but farm machinery industry continued its production. ISAE is in networking role and has created common platform for the academia and industry. The faculties and students are encouraged to work for engineering solutions through Design Innovation Centre. ISAE has developed a strong partnership and networking with global agricultural engineering fraternity. Global Food Security meet was organised in 2015 in South Africa followed by Global Water Security meet in India in 2018. In 2019, 8th Asian-Australasian Conference on Precision agriculture was organized in collaboration with International Society of Precision Agriculture. In 2020, ISAE did exchange of MoUs with NIAE (Nigeria), NSAE (Nepal) and MSAE (Malaysia). Government of India is advocating and developing Incubatees and Start-ups related to farm technology under RKVY-RAFTAAR (MoA & FW, GoI) and ARISE programme. There has been an innovative programme to encourage innovators of different categories. The platforms like TIFAN (Technology Innovation Forum for Agricultural Nurturing) - a platform to solve real mechanization challenges are becoming popular. Government of India has developed a portal to facilitate custom hiring and also coming up with a national portal to encourage innovators. Industry – Institution – farmers – innovators linkage is going to achieve SDGs goals through appropriate mechanization.

## REFERENCES

Srivastava, A. P., Samuel, D. V. K. and Mani, I. 2009. *Mechanization of Vegetable Production and Post-harvest Management*. Westville

Publishing House.

- Mani, I., Srivastava, A. P., Panwar, J. S. and Kumar, M. 2004. Patterns of Sugarcane Mechanization and Transportation in Western UP. *Agricultural Engineering Today*, 28 (1and2), 39-46.
- Mani, I., Srivastava, A. P. and Panwar, J. S. 2002. Pattern of Agricultural Mechanization in Sugarcane Belt of Western Uttar Pradesh. *AMA - Agricultural Mechanization in Asia, Africa and Latin America*, 33(2), 55-59.
- Mani, I. 2013. Promotion of Agricultural Mechanization? Case of India. *AMA - Agricultural Mechanization in Asia, Africa and Latin America*, 44(4), 18-19.
- Parray, R. A., Mani, I., Kumar, A., Khura, T. K. and Lande, S. D. 2016. Pilot study of farm power-machinery status and custom-hiring opportunities in rice (*Oryza sativa*)-wheat (*Triticum aestivum*) cropping system. *The Indian Journal of Agricultural Sciences*, 86(2).
- Paroda, R. S. and Joshi, P. K. (eds) 2017. Proceedings of the National Conference on Sustainable Development Goals: India's Preparedness and the Role of Agriculture. New Delhi, India, May 11-12, 2017. Indian Council of Agricultural Research (ICAR), Trust for Advancement of Agricultural Sciences (TAAS) and International Food Policy Research Institute (IFPRI). 48 pp.
- Mani, I. and Patel, S. K. 2012. Energy consumption pattern in production of paddy crop in haryana state in India. *AMA - Agricultural Mechanization in Asia, Africa and Latin America*, 43(2), 39-42

■ ■

# Smart Farm Mechanization for Sustainable Indian Agriculture



by  
C. R. Mehta\*

Director  
ICAR – Central Institute of Agricultural Engineering,  
Bhopal, Madhya Pradesh 462038  
INDIA

\*Corresponding author: cr.mehta@icar.gov.in



N. S. Chandel

Scientist  
ICAR – Central Institute of Agricultural Engineering,  
Bhopal, Madhya Pradesh 462038  
INDIA



Y. A. Rajwade

Scientist  
ICAR – Central Institute of Agricultural Engineering,  
Bhopal, Madhya Pradesh 462038  
INDIA

## Abstract

Indian agriculture is undergoing transformation due to technological revolution, sprawling urbanization, modern cultivation techniques, and climate change. These changes offer unique challenges and opportunities to transform agriculture to smart, more productive, economically remunerative, socially equitable and environmentally sustainable through adoption of smart mechanization technologies. In this paper, the approaches and strategies are highlighted for sustainable mechanization of Indian agriculture. The smart farm mechanization includes application of sensors, controllers, Internet of Things (IoT), artificial intelligence (AI) and robotics. The research work in the areas of precision agriculture, digital farming, precision irrigation, AI powered machinery, user friendly mobile applications, etc. has gained momentum in India during the last decade. The emerging smart agriculture mechanization combines precision farm with management tools (GPS/GNSS, DSS, VRT), end user ap-

plications (platforms, mobile, machines, Agri-bots), data solutions (data IoT, information, tech empowered tools), etc. These technologies not only make farm machinery smart and efficient but also help in saving inputs such as seeds, fertilizers, chemicals, water and energy for sustainable agriculture.

**Keywords:** Agricultural Mechanization, Artificial Intelligence, Digital Agriculture, Mobile App, Precision Agriculture.

## Introduction

Indian population is expected to reach 2.2 billion by 2050. At the same time, biotic and abiotic stresses, degrading and depleting land and water resources and climate change are major challenges for sustainable agricultural production and productivity. To meet food security of increasing population, India needs to increase its annual food grain production to 333 million tonne by 2050 against 285 million tonnes in 2018-19 (Kapur et al., 2015; DARE-ICAR Annual Report

2018-19, 2019). For this, the farms will need to increase their output by 17% as land for agricultural production becoming a scarce resource. Over the years, Indian farming system has not given an expected remuneration to farmers besides its remarkable growth in food-grain production and processing sectors. However, agriculture remains a principal means of livelihood for over 58% of the rural households and 86% of small and marginal land holdings (Mehta et al., 2019). In addition, as per World Bank estimates, half of the Indian population will be urban by the year 2050. It is estimated that the percentage of agricultural workers of total work force will reduce from 54.6% in 2011 to 25.7% in 2050. This highlights the need to enhance farm power availability and farm mechanisation level in the country (Mehta et al., 2014; NITI, 2018).

Agricultural mechanization is an important symbol of agricultural modernization. The agricultural equipment is the carrier of agricultural modernization and thus an important tool used to promote

agricultural mechanization. The level of economic development has a positive impact on the mechanization level. As India's economy has diversified in recent years, the contribution of agriculture as a proportion of GVA has decreased from 18.2 in 2014-15 to 16.5 in 2019-20. The demand for food in Indian market is growing considerably which requires increasing agriculture production. The level of farm mechanization in USA, Russia, Brazil, China and India has been reported as 95, 80, 75, 60 and 45%, respectively. However, the level of mechanization is inversely proportional to contribution of agriculture in the countries GDPs (World Bank Indicators, 2013; Mehta et al., 2019). Therefore, there is a need for further promotion of farm mechanisation. It is estimated that global market of agricultural implements and machinery is worth around US\$ 200 billion in 2019 and Asian countries are contributing more than 60% to total demand (Kapur et al., 2016; FICCI, 2019).

Presently, the farm machinery in India are being primarily used for production of field crops like cereals, pulses and oilseeds crops. The agricultural mechanization is at an early stage in India and growing at 7.5% per annum in spite of challenges of small land holdings, cropping pattern, market prices of crops, minimum support price (MSP) and government policies and legislations. The ignorance of these challenges will exaggerate the redundant labour force, low return against inputs for yield and ultimately decrease the enthusiasm of farmers in agriculture. Due to lower probability of increase in net cultivated area and scarcity of agriculture labour in the near future, Indian agriculture may require energy intensive agriculture with higher input use efficiency, better soil health management practices and value addition to produce in production catchments.

Within Indian ecosystem, labour-

intensive farm activities are automated, stakeholders (farmers, labours, manufactures, etc.) and decision makers across the value chain are more connected with one another, and information and data, physical products, service and touch point experiences will be united as one integrated solution that solve users/stakeholders needs. In such a complex and rapidly evolving environment, it will be difficult to achieve clarity on what are the biggest emerging opportunities and need of farm machinery manufacturers and service providers to create commercially successful propositions. It will enable the agricultural machinery manufacturing industries for sustainable production in country.

In this paper, the rapidly changing environment in mechanization of Indian agriculture is studied and suggested the approaches and strategies to make Indian agriculture smart based on opportunities in following areas.

## Smart Farming

Smart farming is a management concept using recent technologies such as precision agriculture and digital agriculture to improve quality and quantity of farm produce as well as input use efficiency. These techniques are well supported by artificial intelligence for weather prediction, detection of pest and diseases, site specific application of water and nutrients, optimize crop planning for maximizing yield and profit.

The applications of new technologies viz. precision agriculture, digital agriculture and artificial intelligence (AI) are heralding the start of a new revolution in agricultural production. The recent and emerging technological development such as Internet of Things (IoT), drones and robots, are accelerating changes around the agricultural mechaniza-

tion across the world. Taken together and deployed effectively, these emerging trends and technologies have the potential to usher in a new golden age of smart agriculture.

## Precision Agriculture

Precision agriculture (PA) technologies can help to meet new challenges by applying the right inputs (seeds, fertilizers, chemicals, water, etc.), in the right amount, at the right place, at the right time, and in the right manner. The importance and success of precision agriculture lies in these five "R". Presently, research on precision agriculture is at initial stage and developed technologies are in laboratories in India. The PA technologies such as sensors (soil nutrient, temperature, fertility, and moisture gradients), guidance systems (often enabled by GPS, GNSS, RFID), variable-rate input technologies (VRTs), automated machinery (automatic control and robots) and advanced imaging technologies (including satellite and drone imagery) have been developed to map the variability and manage at field level. A few potential precision agricultural technologies such as fixed rate seed drill, low cost SPAD meter, spectral reflectance (NDVI) based fertilizer applicator, uniform rate sprayer, real time soil moisture based sprinkler irrigation system, automatic irrigation system for rice and automatic yield monitor for indigenous combine harvesters have been developed and tested at ICAR-Central Institute of Agricultural Engineering (CIAE), Bhopal (Chandel and Agrawal, 2019).

The low cost SPAD meter has been developed for indirect measurement of chlorophyll content of leaves in the field crops (Anonymous, 2017a). It is a compact handheld and portable unit and can be plugged to OTG enabled android smartphone for display and data logging of SPAD values. Two row on-the-go variable rate spectral reflectance based urea applicator for top

dressing has been developed for rice and wheat crops (**Fig. 1**). It is 5.5 kg in weight and has swath width of 4 m. The NDVI based variable rate fertilizer application system resulted in 8-15% savings in application of urea fertilizer in wheat and rice crops in areas with spatial nitrogen variation (Anonymous, 2016). The GPS based variable rate fertilizer applicator has also been developed. The application accuracy of the applicator ranged from 89.3% to 98.1% at various discharge rates for 8 × 8 m size grid (Mehta, 2015; Chandel et al., 2016).

An ultrasonic sensor based spraying system, sensor-based system for sugarcane bud cutting and planting, tractor-implement monitoring system, automatic depth and draft control for fuel economy and image based herbicide applicator have been developed and tested at IIT, Kharagpur. The percentage saving of chemical by tractor operated ultrasonic sensor-based pomegranate sprayer was 25-30% and 45-50% with turbo nozzles and hollow cone nozzles, respectively as compared to whole field spraying system (Mehta, 2015). Further, Punjab Agricultural University (PAU), Ludhiana has developed an optical sensor (Yara) based fertilizer application system, an automatic EC and pH mapping system and a batch type yield monitoring system for indigenous combine harvesters. The real-time uniform rate spraying system has been developed at ICAR-CIAE, Bhopal. It helped in uniform application of

chemical and reduced loss of chemicals during turning at head lands (**Fig. 2**). The results of these precision technologies are encouraging, however, their adoption on large scale is lacking due to high cost of these machinery.

### Digital Agriculture

Digital agriculture (DA) consists of a wide range of technologies, most of which have multiple applications along the agricultural value chain. These technologies include cloud computing/big data analysis tools including block chain and smart contracts, the Internet of Thing (IoT), digital communications technologies (mobile phones) and digital platforms (e-commerce, agro-advisory apps, e-extension websites). The government of India has planned to digitize farming system for sustainable agriculture productivity. Agricultural research institutions, universities, and other organizations are working on digital farming to solve various agriculture related problems. IIT Bombay in collaboration with Japan has developed a Geo-ICT and WSN based DSS for agriculture/environment assessment. Under the Information Technology Research Academy (ITRA) project at IIT Kharagpur, work has been carried out on applications of IoT and UAVs in smart farming. The Coordinated Programme on Horticulture Assessment Management using geoinformatics (CHAMAN) was initiated in 2014 for area assessment and production

forecasting of 7 major horticultural crops on pilot basis using sample survey methodology and remote sensing technology across 12 states. The project “Forecasting Agricultural Output using Space, Agro-meteorology and Land (FASAL)” based observations is one of the successful initiations under digital agriculture and is an AI-powered IoT-SaaS platform for horticulture crops. It has raised \$1.6 million in seed funding to build a world-class solution for two core problems of horticulture farmers to manage irrigation and diseases/pests. The sensor array can be installed in field by farmers in less than 15 min and measures multiple dynamic variables, including micro-climate, soil and crop conditions. It uses machine learning (ML) to transform the sensor data into farm level predictions, which help farmers anticipate various risks and reduce input costs by optimizing crop protection, irrigation and crop nutrition. The introduction of a low-cost, mobile phone-based agricultural extension system among 1,200 farmers in the state of Gujarat had a positive and significant effect on agricultural yields and efficient input use in cotton cultivation. As a result of using this service at a cost of less than \$10/year/farmer, farmers’ marginal net income increased by approximately \$100/year/farmer and yields increased by 8.6% for cotton and 28.0% for cumin crops (Anonymous, 2019). On the other hand, digital technologies involved in e-commerce platforms, e-exten-

**Fig. 1** NDVI based variable rate urea applicator for rice and wheat crop



**Fig. 2** Sensor based real-time uniform rate spraying system



sion services, warehouse receipt systems, block chain-enabled food traceability systems, tractor rental apps, etc. fall under the umbrella of digital agriculture.

Marut Dronetech, a start-up, has developed an intelligent and autonomous drone for spraying application in agriculture. The drone collects data, analyses them and generates disease map of a particular field with the help of RGB (red, green, blue), hyper, multi-spectral cameras and powerful sensors. Drone takes the payload with it and sprays the targeted areas using a predefined route. The start-up is presently working with input manufacturers and Farmer Producer Organisations (FPOs) to provide services (Kurmanath, 2019). It has already covered about 2,000 ha of crops by targeted spraying of pesticides in Telangana and Andhra Pradesh states.

#### **Artificial Intelligence in Agriculture**

Using artificial intelligence (AI) platforms, one can gather large amount of data from government and public websites. Presently, artificial intelligence (AI) based on machine learning (ML) is not extensively used in Indian agriculture for automatic data collection, analysis, decision making and controlling the various tasks using different algorithm and mathematical models. The AI offers vast opportunities for advance application in agriculture. The use of AI with computer vision and robotics is able to build next-generation agriculture equipment those can identify defects in fruits and vegetables, detect stresses in crops, assess nutrient deficiencies in soil, reduce chemical application and harvest high value crops. There is a growing interest in applying AI to develop smart farming practices to minimize yield losses in crops by early warning.

AI based agricultural machinery is becoming more and more intelligent. AI based sensors have become

basic components on autonomous tractors, self-propelled machinery and implements. Within PA and digital agriculture based applications, AI based automated data acquisition will have the highest priority. Microsoft in collaboration with the International Crops Research Institute for Semi-Arid Tropics (ICRISAT), Hyderabad has developed an AI Sowing App powered by Microsoft Cortana Intelligence Suite including Machine Learning and Power BI. The App sends sowing advisories to participating farmers about the optimal date to sow. The best part is that farmers do not need to install any sensors on their farms or incur any capital expenditure. They only need a feature phone capable of receiving text messages. These AI-based sowing advisories led to 30% higher yield per hectare (Microsoft News Center India, 2017).

#### **Precision Irrigation**

Globally, agriculture accounted for 90% of freshwater consumption for irrigating 20-30% of agricultural land of which contribution of surface water and ground water was 60% and 40%, respectively (Chaturvedi et al., 2013; Smilovic et al., 2015). India has 18% of world population, and 4% of world's fresh water, out of which 80% is used in agriculture. Of the net sown area of 140.1 Mha, only 68.4 Mha is net irrigated area (DARE-ICAR Annual Report 2018-19, 2019). With advent of climate change and increase in demand of water for other competitive uses such as domestic and industrial use, water available for irrigation will be limited in future. The conventional surface irrigation methods such as border, check basin and furrow have low efficiency (30-60%). In addition, they have limitations of uniform distribution of irrigation water in terms of space and time, higher seepage and percolation losses and affected by soil type and topography of the land. Precision irrigation methods

such as drip and sprinkler irrigation minimize water loss as water is carried through closed pipelines and delivered at desired rate resulting in higher conveyance and application efficiency. Therefore, there is a huge potential to bring more area under irrigation in India.

The Government of India implemented the National Mission on Micro-Irrigation (NMMI) scheme to enhance water use efficiency in the agriculture sector by promoting appropriate technological interventions like drip and sprinkler irrigation systems and encouraging the farmers to use water saving and conservation technologies. The scheme in this form continued up to 2013-14 and is being continued as centrally sponsored scheme on Micro Irrigation under Pradhan Mantri Krishi Sinchayee Yojana (PMKSY). The scheme has benefitted the farmers in term of enhanced productivity and reduced cost of electricity and fertilizers consumption. The average productivity of fruits and vegetables increased by about 42-52% and fertilizer usage reduced by 28%. Besides, the scheme has also succeeded in reducing the irrigation cost by 20-50% and electricity consumption by 31%. Moreover, this led to increase in water use efficiency by 50-90% and farmer's income by 42%. Given its higher efficiency and ease of implementation within months as compared to conventional irrigation projects which need years to create infrastructure to implement, micro-irrigation system can go a long way in addressing the issues faced by country and agriculture sector. The integration of micro-irrigation with watershed projects particularly for utilization of harvested water as aimed under PMKSY too are likely to result in an efficient utilization of available water resources in agriculture with significant savings of water for extending the irrigation facilities to un-irrigated areas.

The indicative costs per hectare of

drip, micro and mini sprinkler irrigation systems are Rs. 25,000-75,000, Rs. 58,000-68,000 and Rs. 85,000-95,000 (One US \$  $\approx$  74 Rs.), respectively depending upon type of crop/spacing/material used and source of water (Anonymous, 2017b). Small and marginal farmers are often not looking at saving of water, energy and fertilizer due to high initial investment of these systems. Therefore, reducing manufacturing cost of the products and/or material replacement or increasing life of system are a few areas for further research.

The sensors available for monitoring of different soil and climatic parameters such as soil moisture and temperature for automated irrigation system are costly and not robust. The number of sensors per unit area and their placement are also important and provide soil moisture data at a particular point at a depth (**Fig. 3**). The wetted area of different micro-irrigation systems need to be considered to provide representative data to decide about number of sensors per unit area for irrigation scheduling. The variable rate irrigation application can be designed considering soil heterogeneity. The yield mapping and/or traditional soil sampling can help to identify different soil zones according to their physico-chemical properties. However, electro-magnetic induc-

tion (EMI) or near-infrared (NIR) system can be used on a field to map spatial soil variability.

The biotic as well as abiotic stresses of plants can be assessed using high resolution imagery. Satellite data, use of unmanned aerial vehicles and drones can be used for procuring high resolution thermal and RGB images for spatial soil moisture mapping/plant water stress monitoring which can be used as inputs for activating an automated irrigation system. These techniques can lead to precision and site-specific irrigation overcoming field variability and soil heterogeneity. The potential of near-surface remote sensing as a scalable platform for collecting high-resolution plot-specific data in addition to local images captured using smart phones can be used in supporting crop damage insurance, crop modelling, and extension for building resilience to yield risk and maintaining sustainable food security in smallholder agricultural systems (Madramootoo and Morrison, 2013).

The real time irrigation scheduling using sensors can be achieved using Wireless Sensor Network (WSN), IoT and AI based technologies. Currently, automation is being practiced using embedded system and micro-controller with the help of solenoid valves in a few Indian

farms. However, these are limited to research level and/or small scale. The research in future should focus on development of irrigation scheduling using techniques such as machine learning, deep learning and artificial intelligence. The compact and robust sensors can also be developed using nano-technology having high accuracy.

### Solar Powered Irrigation

The success of government policies and programs such as PMKSY, National Water Policy, National Mission of Sustainable Agriculture etc., is limited due to India's energy crisis leading to widespread power outages and unscheduled interruptions across rural and urban India. As micro-irrigation systems are operated at standard operating pressure (98-392 kPa), pumps are required to generate desired pressure irrespective of source of water. In India, it is estimated that about 21 million pumps are electricity operated and 8.8 million pumps are diesel engine operated, while only 0.13 million are solar powered pumps. The unscheduled power outages in India also affect the timing and supply of irrigation water to field crops. Although diesel engine operated pumps allow more flexibility as compared to electrical pumps (AC power), but availability of diesel and its cost are the major constraints (Garg, 2018).

The solar irrigation system consists of solar cells, electricity generator and pump. In this, solar energy absorbed by cells (panel) is converted into electrical energy by generator and fed as input to motor driven pump. The Government of India through Kisan Urja Suraksha evm Utthaan Mahabhiyan (KUSUM) scheme has planned to provide solar pumps where grid electricity has not reached. The Ministry of New and Renewable Energy of Government of India has launched the scheme to provide subsidy to farmers on installation of solar irrigation pumps

**Fig. 3** Real time soil moisture sensor based automatic sprinkler irrigation system



(SIPs) for their farms. Under the scheme, the farmers will have to spend only 10% of total expenditure to acquire and install a solar pump and 60% of cost will be borne by government and the remaining 30% will be given as loan by the bank as credit.

The solar pumps not only irrigate the farms but also generate safe energy. Farmers can also sell extra power to power supply companies to generate extra income. However, high initial investment and variable yield (discharge) as per the solar radiation are some of the issues for their large scale adoption. The up-front cost of solar pumps, heavily subsidized supply of electricity to the rural sector, poor after-installation maintenance support and lack of awareness of the benefits of solar pumps prevent most of Indian farmers from shifting from less efficient and unsustainable modes of irrigation to solar water pumps.

### Smart Phone Based Apps

Number of smart phone users in India are likely to get double (401 million) by 2020 as compared to 199 million in 2015. With an increasing trend in growth in digital services, Indians downloaded more apps (12.3 billion) in 2018 than residents of any other country except China. This was due to reduction in data cost by more than 95% as compared to 2013. Large number of mobile apps related to agriculture and allied areas have been developed. These apps support weather forecasting/warning, disease and pest management, market updates, crop insurance and payment gateway individually or in combination. Further, these apps can be connected to data acquired from drones, cameras, satellite images for forecasting/predicting plant diseases at an early growth stage.

ICAR-CIAE, Bhopal has developed web-based app to suggest machinery package for different cropping systems of India. The app

suggests farm machinery package based on agro-climatic region, state, district, cropping pattern and power source. The apps also recommend an estimated cost of farm machinery package, list of manufacturers and their addresses. An Android smartphone based app 'KRISHI Yantra' has also been developed (Fig. 4).

The app 'Kisan Suvidha' provides information on weather updates, 5 days' weather forecast, soil information, market prices, location of cold storage system and godowns, etc. The app "CHC Farm Machinery" has been developed for farmers to avail custom hiring services from the nearest custom hiring centre (within 50 km radius). The "Bhuvan Hailstorm" app helps to estimate losses in crop yield due to hailstorm. The information on location (latitude and longitude), crop details and photographs are required by the app as inputs.

### Strategies for Smart Farm Mechanization

Present Indian agriculture is highly labour intensive whereas smart agriculture is all about machines and technologies. The Department of Agricultural Cooperation and Farmers Welfare (DOAC & FW)

and Department of Agricultural Research and Education (DARE) of Government of India are engaged to enhance technical cooperation among state departments of Agriculture/Agricultural Engineering, State Agricultural Universities (SAUs), research institutes and associate members of NARS as well as other interested NGOs, through extensive exchange of information, sharing of knowledge and promotion of R&D and agri-enterprise development in the areas of sustainable agricultural mechanization, in order to attain the nationally agreed development goals.

The research institutes of Indian Council of Agricultural Research (ICAR), SAUs, IITs, NITs and other private organizations are involved in development of technologies based on precision agriculture (PA), digital agriculture (DA) and AI through different projects such as the National Agricultural Innovation Project (NAIP), Consortia Research Platform on Farm Mechanization and Precision Farming (CRP on FMPF), AICRP on Farm Implements and Machinery, etc. These institutes are applying modern tools and techniques for application of sensors and robotics in planting, rice transplanting, auto-guided tractor, drone-based spraying with

Fig. 4 Android smartphone based KRISHI Yantra Mitra app

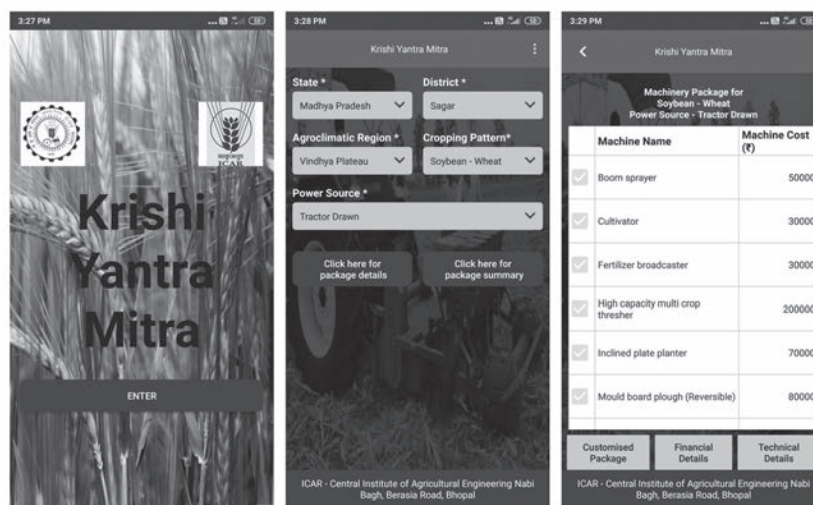



the help of AI, etc. It is vital that these centres should focus on the stakeholders' interests to ensure that research concepts (farming methods and machinery) may not remain at the prototype stage.

The themes of PA, DA and AI in agriculture can be applied across disciplines and may bring a paradigm shift in how we see farming today. The following strategies will not only enable farmers to do more with less but also help to improve quality and ensure faster go-to-market for crops.

1. Promotion of digital farming and precision agriculture technologies in addressing issues related to sustainable farming through research & development and financial assistance.
2. Need for increased application of precision agriculture and smart agriculture with involvement of private sector for farm mechanization.
3. The potential of vertical farming may be harnessed by next generation drones enable with advanced navigation technology and AI.
4. The advancement in agri-bot will directly address the challenge of labour drain and further unlock productivity potential.
5. Establishment of an interactive digital platform to allow farmers full access to information and technology databases, expert systems and DSS for web based agro-advisory, skill development, machinery management and financial assistance.
6. The agriculture should shift focus from productivity per unit area of land to irrigation water productivity. The applications of ground-based sensors and remote sensing data at high spatial and temporal scales can be integrated for forecasting and allocation of irrigation water.
7. Promotion of an app-based farmer-to-farmer aggregation platform, which bridges the demand and supply gap of machinery or

equipment by connecting owners of tractors and farming equipment with those who require their services.

8. Human resources development of scientists and technical manpower in smart agriculture technologies such as AI, precision agriculture and digital agriculture.
9. The drudgery prone and repetitive farm operations such as weeding, spraying and harvesting of costly fruits and vegetable can be enabled with AI, leading to improved accuracy and productivity.
10. The data captured/generated by drones can be used to implement crop insurance schemes to evaluate/verify crop damages claims. Farmers can make insurance claims by capturing drone feeds as evidence.

## Conclusions

There are four recurring themes for sustainable smart agricultural mechanization in India.

1. Farm power and agricultural machinery are essential inputs if sustainable agricultural production and productivity are to be increased and managed to feed India's burgeoning population.
2. The intensification of crop production must be sustainable. Its environmental footprint (carbon and energy) must be as low as possible and in any case lower than the rate of natural renewal.
3. Top-down solutions are rarely efficacious. All stakeholders need to be considered from the outset and the private sector must lead the development process on the field.
4. A holistic, value-chain approach is necessary for agricultural mechanization, going beyond green production through precision agriculture and digital agriculture.

If agricultural mechanization efforts are to succeed in India, there is an urgent need for all stake holders

like farmers, manufacturers, supporters, planners or decision makers, to understand and contribute to smart agricultural mechanization efforts across the entire farming system. There is also a need for regional research & development complex and centres of excellence that can guide national policy towards sustainable agricultural mechanization. The large agricultural tractor and machinery manufacturing sector in India requires incentives for the manufacturing of equipment for sustainable mechanized agricultural practices.

## REFERENCES

- Anonymous. 2016. Modernizing agriculture through engineering intervention; April-June 2016.26 (2). [http://www.ciae.nic.in/Content/660\\_1\\_Newsletter.aspx](http://www.ciae.nic.in/Content/660_1_Newsletter.aspx)
- Anonymous. 2017a. Modernizing agriculture through engineering intervention; April-June 2017.27 (2). [http://www.ciae.nic.in/Content/660\\_1\\_Newsletter.aspx](http://www.ciae.nic.in/Content/660_1_Newsletter.aspx)
- Anonymous. 2017b. Operational guidelines of per drop more crop (micro irrigation) component of PMKSY, Govt. of India. 59 pp. <https://pmksy.gov.in/MicroIrrigation/Archive/GuidelinesMIR-revised250817.pdf>
- Anonymous. 2019. Precision agriculture for development, Inc.32 Atlantic Avenue, Pilot House - Lewis Wharf, Boston, MA 02110 USA. <https://precisionag.org/where-we-work/india/pad-lab/>
- Chandel, N. S. and Agrawal, K. N. 2019. Yield variability assessment in paddy crop using automatic yield monitoring system. *Journal of Agricultural Engineering*, 56(3), pp.158-165.
- Chandel, N. S., Mehta, C. R., Tewari, V. K. and Nare, B. 2016. Digital map-based site-specific granular fertilizer application system. *Current Science*, 1208-1213.
- (Continued on page95)*

# Agricultural Mechanization in Bangladesh: Status and Challenges towards Achieving the Sustainable Development Goals (SDGs)



by  
Anisur Rahman  
Associate Professor  
Dept. of Farm Power and Machinery,  
Bangladesh Agricultural University  
Mymensingh - 2202, BANGLADESH  
anis\_fpm@bau.edu.bd



Md. Rostom Ali\*  
Co-operating Editor, AMA and Professor  
Dept. of Farm Power and Machinery,  
Bangladesh Agricultural University  
Mymensingh - 2202, BANGLADESH  
\*Corresponding author: rostomfpm@bau.edu.bd



Md. Shaha Nur Kabir  
Associate Professor  
Dept. of Agricultural and Industrial Engineering,  
Hajee Mohammad Danesh Science  
and Technology University  
Dinajpur - 5200, BANGLADESH  
mskhstu@gmail.com



Md. Mostafizar Rahman  
Associate Professor  
Dept. of Agricultural Engineering,  
Bangabandhu Sheikh Mujibur Rahman Agricultural  
University  
Gazipur - 1706, BANGLADESH  
mostafizar-age@bsmrau.edu.bd



Md. Rashed Al Mamun  
Professor  
Dept. of Farm Power and Machinery Sylhet  
Agricultural University  
Sylhet - 3100, BANGLADESH  
rashed.fpm@sau.ac.bd



Md. Anwar Hossen  
Senior Scientific Officer  
Farm Machinery and Postharvest  
Technology Division  
Bangladesh Rice Research Institute (BRRI)  
Gazipur-1701, BANGLADESH  
ahossenbri@gmail.com

## Abstract

Bangladesh is predominantly an agrarian country with agriculture is the most important sector. Varieties of crops cultivated in large quantities in the country due to its fertile land and favorable weather. Mechanization is an essential input in the agriculture of any country. For increasing crop production and reducing field losses, mechanization is inevitable in the agriculture of Bangladesh. This review article has focused the present status, challenges, and prospects of agricultural mechanization towards achieving the Sustainable Development Goals

(SDGs) in Bangladesh. At the beginning, the article has overviewed the presents status and trends, later the impact of agricultural mechanization and the status of precision farming. Finally, the challenges and prospects of sustainable agricultural mechanization have been discussed. The major findings of this study are as follows: Government has taken a mega project to handover huge numbers of farm machineries through subsidy program; Government of Bangladesh is trying to patronize local machinery manufacturers for more productive and self-dependent; all levels stakeholders are giving significant effort to accelerate ag-

ricultural mechanization; employment opportunity of relevant human resources in DAE and other organizations has been started which will be enhanced farm mechanization; researches on smart farming system, agro-entrepreneurship and handling of modern farm machines in the field level has been considered especially; private organizations are importing demand based machines and providing credit loan system; national agricultural mechanization policy in alignment with SDGs has been approved recently which will be an appropriate guideline for implementation of modern farming system in Bangladesh.

## Introduction

Bangladesh is an agricultural country where this sector contributes about 14.2% of the country's GDP, with a growth rate of 0.5% (BBS, 2018). The main staple crop is paddy, accounting for 74.85% of the total cropped area and 95% in production. With the growth of population, by 2030 the population of Bangladesh would be about 200 million that need to double the production of paddy in Bangladesh. On the other hand, the current labor force employed in on-farm agricultural activities is about 43%, and that would have been reduced to about 36.1% by 2020 (BBS, 2020). That poses a significant challenge to Bangladesh's agriculture for almost double the present paddy production with the decreasing number of labour force. To face the challenge of feeding the growing population, the demand for agricultural mechanization as an essential input has been recognized by our policymakers and planners.

Bangladesh has a long history of agricultural mechanization. The country has taken various paths on the way to agricultural mechanization. Before the independence of Bangladesh, different irrigation technologies like large-scale canal systems, deep tubewells, swing buckets, and dhones were used. Rural entrepreneurs of public and private sectors were sold water lifted by the heavy engine operated low-lift pumps. After independence, the government of Bangladesh has changed irrigation policies, especially shallow tubewells for groundwater, and low-lift pumps for surface water were promoted (Biggs and Justice, 2015). In the 1980s, shallow tubewells powered by Chinese diesel engine and two-wheel tractors (2WTs) by Japanese aid were spread in Bangladesh. In 1989, about 5,000 2WTs, 15,519 deep tubewell, 223,588 shallow tubewell, 57,200 low lift pump, 3,000 open drum

thresher, and 1,000 closed drum thresher were available in Bangladesh (Biggs and Justice, 2015). In the early 1990s, a huge number of elements of agricultural mechanizations, including shallow and deep tubewells with diesel engines and 2WTs for tillage operation have been provided to a significant number of farmers and service providers in Bangladesh. Later on, efforts were made to introduce different types of machinery to motivate farmers and service providers to use these machines such as reapers, seeders, and conservation agriculture machines such as zero-till and bed planting. The widespread adoption of these machines by smallholder farmers is still to be achieved (iDE, 2012).

The fourth-largest rice producer country Bangladesh has achieved self-sufficiency in rice production (Gurung et al., 2017). For the timely completion of cultivation related activities, reducing production losses, and overcome the shortage of labor, acceleration of agricultural mechanization is urgently necessary for Bangladesh. In alignment with the existing production and mechanization status, farmers, government, and non-government sectors are doing their best to accelerate the mechanization in agricultural processes. The government of Bangladesh has been formulated mechanization strategies in connection with SDGs. To attain the SDGs related to agriculture, agricultural production should be doubled per acre by 2030 for which further mechanization of agricultural processes is needed.

The demand of effective agricultural machinery including combine harvester, reaper, rice transplanter, power thresher, power weeder, power sprayer, drier, potato digger, maize sheller, and fertilizer distributor is increasing day by day. Besides imports, local machinery manufacturers meet 20% demand of agricultural machinery in Bangladesh. The government has taken an initiative to hand over 56,000 agricultural

machinery to the farmers through a mega project worth Tk 3,020 crore (30.2 Billion USD) started in 2020. In the project, the government will patronize the local machinery manufacturers for building capacity so that they will be more productive and self-dependent. Farmers and service providers will get an opportunity to purchase agricultural machinery in the haor area at 70% subsidy and 50% subsidy in other areas (Seraj, 2020). In the project, the government has aimed to reduce post-harvest losses of crops, including the main crop rice, by up to 15%, save 50% time in cultivation time and cut costs by 20% (Parvez, 2020).

There are several agricultural universities (BAU, Sylhet-AU, Sher-e-Bangla-AU, BSMRAU, HSTU, PSTU, KAU), public organizations (DAE, BRRI, BARI, BINA, BSRI, BJRI) and private organizations (ACI Motors limited, The Metal (Pvt.) limited, Alim Industries, Mahbub Engineering workshop, Bangladesh Machine Tools Factory, Chittagong Builders and Machinery limited, iDE, CSISA-BD, CIMMYT, FAO, etc.) are giving services in different ways for accelerating mechanization with the aimed of resources conservation, reduction of losses and reduction of the unit cost of production. All of them are being suggested custom hiring service provision models and community-based cultivation and precision agriculture for the appropriate scale of agricultural mechanization so that small-holders may get easy access to all kinds of agricultural machinery.

Precision agriculture (PA) is a crop management strategy that uses information technology to collect, process, interpret, decision-making, and implement field or crop data to increase productivity and reduce risks. Among various PA technologies, GPS and GIS seem quite practical from Bangladesh's perspective. GPS can also be used to identify the causes of inefficiencies, such as

machine idling, and can help make better decisions to increase productivity. In combination with GPS, GIS may aid in controlling the navigation of farm vehicles. Information obtained from the GIS can be used to control various processes, such as seeding, planting, fertilizer, and pesticide application at an appropriate rate and manner. Precision agriculture technologies can increase productivity by manifolds. The Department of Farm Power and Machinery (FPM) at Bangladesh Agricultural University, DAE, BRRI, BARI, SPARRSO are playing a vital role in the research of precision agriculture technologies. They are emphasized various PA technologies like GPS, GIS, and others through various active projects. Different research organizations and universities may give more special focus to PA technologies as they hold great prospects. Most of the farmers in Bangladesh are poor and have little to no education, so to make precision agriculture popular and sustainable proper training through agricultural extension service is essential. All available and prospective communication channels must be utilized to disseminate information. Moreover, proper guidelines and national policy are imperative. Government incentives for public and private sectors may go a long way (Ali, 2020).

Although progress of agricultural mechanization in Bangladesh is slow but recent activities on agricultural mechanization is satisfactory. All of the stakeholders, including the government, are giving their best effort to accelerate agricultural mechanization. The review article aims to present the present status, challenges, and opportunities of agricultural mechanization towards achieving sustainable development goals (SDGs). A brief history of the development and prospects of agricultural mechanization in Bangladesh toward SDGs has been over-viewed in the first part. In the sec-

ond part status, spare parts market, available power, extension activities for agricultural mechanization, in the third part impact of agricultural mechanization on farm women, the livelihood of rural people, non-farm sector, the capacity of importer, local manufacturers, employment and custom hire services, in the fourth part status, research, development, opportunity, and challenges of precision farming and the last part challenges and prospects of sustainable agricultural mechanization has been discussed.

### Trends of Agricultural Mechanization in Bangladesh

#### Status of Agricultural Machinery Used in Bangladesh

Bangladesh agriculture has gone through a remarkable change since the 1990s with the liberalization of the agricultural machinery market and the emergence of machinery business owned by an individual or an independent, commercial company rather than by the government. Besides import and after-sale service provisions rendered by the private sector companies, agricultural machinery manufacturing sub-sector in the country has been

growing significantly. The status of agricultural mechanization in different stages of activities is mainly rice cultivation as illustrated in Fig. 1.

A study revealed that the tilling is almost mechanized and the farmers have access to 2WTs custom-hiring service about 94%, whereas access to 4WTs is only 3%. However, timely access to these tilling machines is not smooth in all areas of the country and timeliness loss and cost of production are still significant. Of the mechanized irrigation, about 66% and 33% of the equipment were powered mechanically and electrically, respectively. The shares of DTW, STW, LLP, and treadle pump were about 32%, 47%, 20% and 1%, respectively. The use of hand and knapsack sprayers were found about 23% and 77%, respectively, of which 93% were operated by human muscle power and only 7% mechanically. The contribution of different types of foot-operated thresher, open drum thresher (ODT) and power operated closed drum thresher (CDT) were about 14%, 15% and 45%, respectively. The shares of pedal thresher, open drum thresher (ODT) and closed drum thresher (CDT) were about 14%, 15% and 45%, respectively. However, about 22% of traditionally beating by hand and treading by

Fig. 1 Percentage of agricultural mechanization in different stages of agricultural activities for mainly rice cultivation (Hossen, 2019)

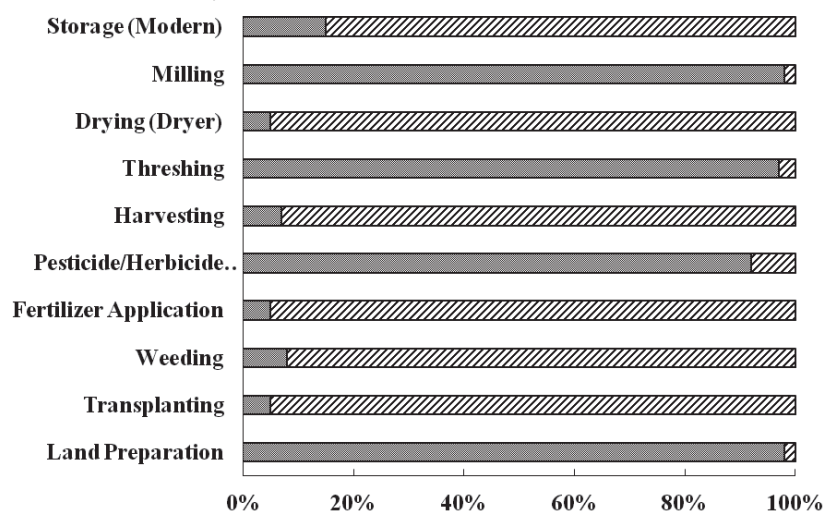

the animal of 4% were still in use for threshing operation. Winnowing was found enormously manual; however, about 12% of farmers were using power tiller (PT) and electric power-operated stand fan for cleaning purposes. Drying of the crop was found totally manual and mainly depended on nature where farmers used concrete drying floor (Chatal), soil hard floor, off-road and tin shed as 36%, 49%, 7% and 5%, respectively. Of the mechanized transportation of agricultural commodities, the tractor and PT shares were found 8% and 64%, respectively. Only about 8% of farmers were found using cold storage for potato storage. Other agricultural products were stored at homestead using traditional storage technologies (Alamand Khan, 2017b). More attention needs to be paid for successful mechanization, which will help to attain SDGs and employ skilled manpower for efficient management of agricultural machinery by selecting, identifying, and propagating suitable equipment based on the soil, crop, yield, and farmer needs and culture of a particular area. In this regard, it is necessary to establish links among the different stakeholders to attain the SDGs in Bangladesh.

### Available Power in the Agricultural Operation

The level of available power in an agricultural farm is one of the ways to determine the stage of mechanization. During the last 58 years, the average farm power availability in Bangladesh improved approximately 1.82 kW/ha in 2018 from about 0.24 kW/ha in 1960, as given in **Fig. 2** (Hossen, 2019). The power availability in Bangladesh increased from 0.4 kW/ha in 1990 to around 1.4 kW/ha in 2011, whereas India's power has also achieved steady growth from 0.92 kW/ha in 1995/96 to 1.84 kW/ha in 2012 (Alamand Khan, 2017b). Many countries witnessed remarkable growth in mechanization example, China's power availability per hectare reached 3.56 kW in 2011 and its overall mechanization rate raised from 35% in 2004 to 59% in 2013.

### Present Status of Agricultural Machinery

In recent years, the degree of agricultural mechanization has been begun to move more quickly in Bangladesh. But the level of its overall progress is still comparatively low compared to the fully mechanized countries. At present, 80% of the land is prepared by PT and 18% by tractor or 2WTs and/or 4WTs (Islam, 2018; Kienzle et al., 2013).

However, mechanization of other agricultural field operations is still very low in Bangladesh; thus, the adoption of other agricultural equipment such as bed makers, seeders, weeders, harvesters and winnowers is not common (Islam, 2018). One of the strategies can make double farm production per acre by 2030, for which further mechanization of agricultural processes, particularly harvesting, transplanting and packaging, is a considerable indicator. **Table 1** presents the existing scenario of agricultural machinery available in Bangladesh.

### Research and Development of Agricultural Machinery in Bangladesh

The Department of Farm Power and Machinery of Bangladesh Agricultural University (DFPM-BAU), Bangladesh Rice Research Institute (BRRI), Bangladesh Agricultural Research Institute (BARI), Bangladesh Sugarcane Research Institute (BSRI) and newly established agricultural universities are engaged in research and development of agricultural machinery and technologies suitable for the socio-economic and technological condition of Bangladeshi farmers. However, a very good number of agricultural machinery has been developed in these institutes.

The DFPM-BAU developed some machinery and equipment such as Neck harness, improved animal-drawn plough, Manually operated seed drill, Orchard sprayer, BAU-ZIA seed fertilizer distributor, Self-propelled BAU reaper, Solar tunnel drier and BAU-STR dryer. In last five and half years, a group of academicians and researchers of DFPM-BAU are giving field level training on agro-entrepreneurship development, operation and repair & maintenance of agricultural machinery with the involvement of women and youth under Feed the Future (FtF), USAID funded appropriate scale mechanization innovation hub (ASMIH)-Bangladesh and post-

**Table 1** Present status of agricultural machinery in Bangladesh (MOA, 2016; Islam et al., 2017)

Name of the machine	Quantity, no.	Name of the machine	Quantity, no.
Diesel engine	2,500,000	Weeder	250,000
Power tiller	700,000	Seed-cum-fertilizer distributors	60
Tractor	60,000	Granular urea applicator	1,600
High-speed rotary tillers	>4,000	Prilled urea applicator	18,000
Seeder	5,000	Sprayer	1,300,000
Rice transplanter	322	Reaper	1,434
Combine harvester	1,430	Power driven pump	167,175
Open drum thrasher	280,000	Deep tube well	35,566
Hand Maize sheller	12,000	Shallow tube well	1,548,711
Power Maize sheller	3,000	Low lifting pumps	77,784
Closed drum thresher	220,000	Manually operated pumps	10,801
Winnowing	3,000	Traditional pumps	64,235
Dryer	600	Solar pump	320

harvest loss reduction innovation lab (PHLIL)-Bangladesh projects. Through these projects, harvesting and transplanting technologies, advanced hermetic storage and drying technologies are being promoted in the field level for reducing post-harvest losses of paddy and other cereal crops in Bangladesh.

The BRRRI has developed 38 technologies out of which BRRRI Rice-wheat thresher, BRRRI open drum thresher, BRRRI weeder (both manual and power) is widely utilized. Some other attractive technologies are BRRRI manual rice transplanter, BRRRI solar light trap, BRRRI rice transplanter cum fertilizer applicator, BRRRI PTO mounted reaper, BRRRI winnower, BRRRI USG applicator, BRRRI prilled urea applicator, BRRRI seed dryer, BRRRI improved oven and rice parboiling system. BRRRI is trying to popularize the developed machinery through different government-funded projects. Research activities are progressing to develop multi-crop seeder, and power tiller mounted reaper, etc.

The BARI has so far developed 25 technologies and equipment. Out of these technologies and equipment, maize shellers, and multi-crop power thresher, weeders are common practices. Some other machinery like mango harvester, potato grader, power tiller operated seeder, reaper, and hot water treatment plant need

to popularize among the end-users and stakeholders.

The BSRI has developed some farm machinery for the cultivation and processing of sugarcane and intercropping. These are small hot water treatment plant, pedal, and hand-operated bud chip cutter, power-operated seed cutter.

Despite all the developments and constraints, manual labour claims the highest input cost in rice production of the country, as it is still essential for transporting, weeding, harvesting, threshing, drying and many other related activities. The farmers and rural entrepreneurs are trying to further mechanize some of these operations to reduce the cost of production and time of operation. Highly coordinated research and extension among government organizations (GOs), non-government organizations (NGOs), and private agricultural machinery manufacturers are required to support this process of mechanization.

### Status of Agricultural Machinery Spare Parts Market

By emphasizing scale appropriate farm mechanization, spare parts made locally can contribute an important role in the country's economy. In general, spare parts of agricultural machinery (such as PT, tractors, combine harvester, transplanter, engine, pump, etc.) are

both imported from overseas like China, South Korea, Japan, Vietnam and India, and locally produced in Bogura, Sylhet, Natore, Jashore, Dhaka and elsewhere in the country. In 2011, the estimated spare parts market size in Bangladesh was about US\$ 325 million of which local production size was about US\$ 250 million (Tiwari et al., 2017; Alam et al., 2017). On the other hand, in 2019, the spare parts market size was reached about US\$ 369 million of which the local share was about US\$ 295 million (Fig. 3). This means the significant changes in the supply chain of available spare parts each year develop potential local spare parts manufacturers and reduce the use of imported spare parts in the country (Alam et al., 2017).

This trend is not only saving a huge amount of foreign currency but also reducing the dependency on imported spare parts. In addition, Bogura city is now becoming famous as the largest industrial area for agri-machineries and its spare parts in Bangladesh, where around 80% of machines and spare parts such as irrigation pumps, threshers, maize shellers, piston, liner, etc. are manufactured, and the rest of 20% is made in Dhaka and Jashore district. Yet, infrastructures are insufficient for the production of agri-machinery and its spare parts sub-sector in Bogura and elsewhere in

Fig. 2 Status of mechanical power in agriculture over the period

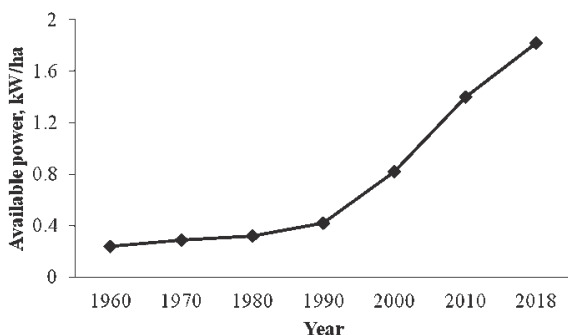
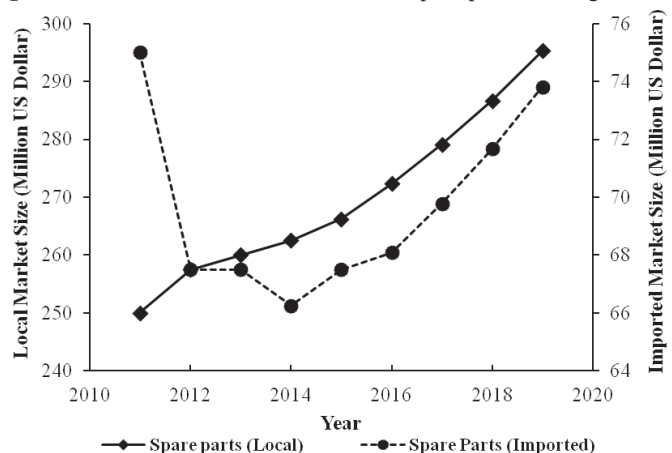

Fig. 3 The estimated annual market size of spare parts in Bangladesh



Bangladesh. A significant number of skilled and semi-skilled workers are also employing in that sub-sector, and further, it is creating opportunities for employment, even then, this sub-sector is still facing ignominy from the proper concern of policymakers in the country (Alam et al., 2017). Moreover, for sustainable production of spare parts, GoB must have to pay proper attention to providing merits on credit to local machinery manufacturers for establishing standard manufacturing plants for spare parts which will further enhance to attain SDGs in the country.

### Importer and Manufacturer of Agricultural Machinery

Around 65 importers are available in the country, of which about 14 importers import tractors and rotavators from China and India. Out of 14, only four importers such as Metal, ACI, Abedin and Alim industries are mainly importing combine harvester, reaper and rice transplanter from China, Japan, South Korea, Vietnam and India. In

addition, around 51 importers out of 65 are importing all kinds of small agricultural machinery like power tiller, diesel engine, pump, knapsack sprayer and spare parts, respectively. Nearly 100% power tillers (model name Dongfeng and Sifang) are imported only from China, which is widely using in Bangladesh, whereas sprayers (either power or knapsack sprayer) and irrigation pumps are importing from China, South Korea and India (Islam, 2018). However, sprayers and irrigation pumps have now been manufactured locally. In 2019, the approximate annual market size of agricultural machinery was reached US\$ 1.28 billion in Bangladesh (Table 2). About 1300 nos. of combine harvester and 934 nos. of reaper were provided this year, of which about US\$ 42.73 million was expensed due to the timely harvesting of paddy in the absence of labors in the rural area. Generally, Janata engineering is an agricultural machinery manufacturer company even though they are importing reaper and rice transplanter in the country. Besides, Chittagong

Builders and Machinery Group (CBM) imports the largest number of PTs and diesel engines, which is the leading agro-equipment based machinery company in Bangladesh. Beyond import of this machinery from abroad, currently about 70 foundries, 800 agro machinery manufacturing workshop, 1500 spare parts manufacturing industries and workshops, and around 20,000 repair and maintenance workshops are running in production and servicing of agricultural machines and spare parts in the country (Islam, 2018; Alam et al., 2017). There are also few agro-machinery workshops and industries in Bangladesh are playing a pioneering role in manufacturing different kinds of farm machinery, which are Alim Industries Limited, Sylhet; Rahman Engineering Workshop, Kushtia; Mahboob Engineering, Jamalpur; Comilla Cooperative Karkhana, Comilla; Janata Engineering, Chuadanga, and Uttaran Engineering Workshop, Dinajpur and MAWTS, Dhaka. Like these manufacturers, lots of small manufacturers in different parts of the country has been established to fabricate irrigation pump, knapsack sprayers, thresher, seeder, maize sheller, rice milling equipment and spare parts of the engine and power tiller, and meet the local demand (Islam, 2018). In addition, Metal (Pvt) Limited and Agro Machinery Industry Ltd. are manufacturing farm machinery such as thresher, USG applicator, sprayer, drum seeder.

But, very few manufacturers have research and development sections by which farm machinery can be modified according to the farmers' demands. Unlike imported machines and spare parts, local production of agricultural machines and spare parts can also play a vital role in Bangladesh whether appropriate action planned on mechanization is taken for this sub-sector (Alam et al., 2017). Besides, machinery importers can also set up an assembly

**Table 2** Approximate market size (in million US\$) of agricultural machinery in 2019

Agricultural Machinery	Qty	Average Unit Price, US\$	Total, Million US\$
Power Tillers	45,000	1,562.50	70.31
Tractor	8,000	15,000.00	120.00
Rotary Tiller	3,000	2,500.00	7.50
Combine Harvester	1,200	31,250.00	40.63
Reaper	600	2,250.00	2.10
Transplanter	100	5,000.00	0.50
Pump	750,000	187.50	140.63
Engine	1,200,000	250.00	300.00
Thresher	20,000	562.50	11.25
Seeder	100	937.50	0.094
Weeder	500	2.50	0.001
Sprayer	700,000	18.75	13.13
Maize sheller	7,000	625.00	4.38
Total Farm Machinery Market Price (including with Imported and Local)			710.50
Repair & Maintenance Cost (around 5 -7 % on total value for the first year)			35.53
Existing Machinery Repair and Maintenance Cost (around 15% on the total value of sold machinery in the last 5 years)			532.88
<b>Agricultural Machinery Market Size in Bangladesh</b>			<b>1,278.92</b>

Source: Alim Industries Ltd., Sylhet, Bangladesh

wing where agricultural machines will be assembled, which will reduce the dependency of imported machines and the overall cost of farmers to buy these machines, accelerate sustainable mechanization in Bangladesh, and achieve the target of SDGs in agriculture.

### **Extension Activities for Agricultural Mechanization**

Field demonstration plays a vital role in developing awareness among farmers and rural society. Government of Bangladesh (GoB) is continuously trying to expand the agricultural mechanization works throughout the country. The Department of Agricultural Extension (DAE) is the government organization under the Ministry of Agriculture (MoA) providing advisory supports to the framers regarding all kinds of problems and solutions in agriculture. Agricultural Engineers of DAE are conducting large-scale demonstrations and training programs under different GoB projects among farmers related to farm machinery and technologies used in agriculture in their respective district and Upazilla agricultural extension offices. The GoB projects raised tremendous impinge on the disseminating of mechanized agricultural operations like cultivation, harvesting, threshing and transplanting in Bangladesh. In 2009-12, DAE conducted a project named “Enhancement of Crop Production through Farm Mechanization Project Phase-I,” funded by GoB to outreach the farm machinery throughout the country under subsidy program, of which farmers have received 25% assistance from the government to procure the farm machinery. Recently viewed, DAE has also been executed the five-year project named “Enhancement of Crop Production through Farm Mechanization Project Phase-II” funded by GoB for 2013-2018 in all over the country. Under this project, the amount of subsidy was increased up to 50% so that farm-

ers can easily purchase all kinds of farm machinery, especially seeder, transplanter, reaper, mini combine harvester and thresher (Islam, 2018). In the fiscal year of 2019-2020, DAE also executed GoB allocated Tk 200 crore subsidized for the development support in agricultural mechanization for the farmers, including with Tk 100 crore additional fund due to COVID-19 pandemic where the subsidy on purchasing of agricultural machinery was 50-70%. In addition, the government was supplied combine harvester, reaper, and transplanter in haor agriculture under full assistance, which usually is inundated by the flash flood. However, the expansion of agricultural mechanization depends on the combined contribution of different stakeholders who have access to mechanization such as government, research institutes, extension agents, development partners, manufacturers, traders, dealers, and farmers. In 2016-2018, DFPM-BAU and BARI were conducted USAID funded project named “Appropriate Scale Mechanization Innovation Hub (ASMIH)” to adopt the farm machinery in the southern region (Alam and Khan, 2017b). The research institutes such as BARI and BRRI are also developing on-farm and post-harvest machinery regarding the country's perspective and adapting to the farmers through field demonstration, training, and logistics support. Likewise, the government and research institutes, development partners such as IRRI, CIMMYT, JICA, iDE, ACIAR, FAO, KOICA and NGOs contribute to the extension of farm machinery and technologies with providing proper training and logistic support to the end-users. The Ministry of Agriculture (MoA), academic institutions, research institutions, development partners and manufacturers arrange frequent fruitful seminars, workshops, motivational tours and field day to introduce the current research outputs on the issues, opportunities

and constraints of farm mechanization in Bangladesh (Islam, 2018). Moreover, GoB can provide an integrated IoT controlled software/application to the district agricultural offices from where supervision and monitoring could be performed on Upazila extension workers in the field for proper dissemination of agricultural technologies for achieving sustainable mechanization in Bangladesh.

## **Impact of Agricultural Mechanization and Farm Machinery**

### **Livelihood of Rural Poor**

The BAU farm mechanization project (popularly known as REFPI completed at 2003) evaluated that the achievements of interventions made real impacts on the poor's livelihoods despite the relatively small scale and the short period of implementation of RD & E projects. A wide and often unanticipated range of livelihood impacts were associated with increased accessibility to and information on farm power by the rural poor. Increased access to farm power information and technology has increased labour productivity, reduced labour shortage bottlenecks, and reduced workload and drudgery, especially for women. It's created livelihood opportunities for renting out implements, often by the landless, creating a skilled labour pool amongst agricultural labourers. It also improved service available for those who can not afford individual ownership of machinery, generated employment opportunities, stimulated entrepreneurship at the local level, and empowered partners, entrepreneurs and women. (Turton and Afsar, 2002). It is also revealed that the development and extension of farm power technology is an important entry point for improving the poor's livelihoods. Indeed, it might extrapolate further that: ‘If the poor are not given the



appropriate support for access to farm power and technology, they are at risk of being further marginalized from development processes' (Turton and Afsar, 2002).

### **Impacts on Farm Women**

Initially, the farm mechanization has displaced women labourers from their traditional jobs but due to the recent diversification of farm activities, employment opportunities have been created jobs for women both in farm and non-farm activities. The mechanization very selective in the recent past has created ample scope to save time and reduce the drudgery of work so that women could invest time in other household and income-generating activities. It has been observed that the introduction of mechanized threshers, irrigation devices, weeders, hulling machine/dehusker and power operated small processing units has made a remarkable impact on women's role in rural areas as income-earning members, contributing to women empowerment and participation in decision making. This has also increased the social and physical capital of the family women in Bangladesh.

### **Impacts on Rural Non-farm Sector**

During the last couple of decades, rapid growth and transformation in agriculture have triggered a significant expansion of rural non-farm activities. The rapid growth of irrigation and power tillage technologies has stimulated various manufacturing and services activities at the local level. These include manufacturing and trading of farm machinery and equipment spare parts, machinery installation, repair and maintenance services, inputs and grain trade, crop and food-processing, rural transport, rural trade and shop-keeping, etc. The rise in rural household income has resulted in a rapid increase in demand for materials and services in house construction, rural sanitation, household materials and personal

services.

### **Capacity of the Importer and Local Manufacturers**

In recent years, the growth of local agricultural machinery and implement the manufacturing industry is expanding to fulfill the local demand (Islam, 2018). LLPs, STWs, sprayers, weeders, paddy and wheat threshers, maize shellers, engine and machine spare parts are being manufactured locally. The local manufacturers are also developing locally adaptable machinery to meet the demand for small-scale farming. They fabricate frames and implements for PTs, tractors, threshers, and other machinery using imported engines to power the machines (Animaw, 2016). These small and medium enterprises are lacking in advanced manufacturing experiences and technical knowledge. Furthermore, lacking appropriate capital machines, design, drawing, and manufacturing processes have resulted in these enterprises in producing poor quality products (Alam et al., 2017).

The agricultural machinery import sector has grown dramatically along with a great contribution to the growth of local manufacturing of agricultural machinery and spare parts (Justice and Biggs, 2013). Some potential private companies are working to mechanize the agricultural sector in Bangladesh. These private sector companies import PTs, tractors, rice transplanters, reapers, and combine harvesters to overcome the labour scarcity in planting and harvesting seasons (Alam and Khan, 2017a). Importers of this agricultural machinery have well-established networks throughout the country providing after-sales services with warranties to the machinery owners.

A number of initiatives have been attempted by the public and private sectors of Bangladesh for the successful adoption of agricultural mechanization. Recently, Bangla-

desh's government provided subsidies up to 50-70% on different types of agricultural machinery such as tractors, power tillers, combines harvesters, etc. These subsidies are enhancing the farmers to access new agricultural machinery. Since the demand and market of agricultural machinery are expanding rapidly, supporting the production of local agricultural machinery and spare parts are needed to boost the sustainable agricultural mechanization. The importers, local manufacturers, and dealers are also promoting the benefits of using agricultural machinery through street advertisements and signboards.

However, imported agricultural machinery and spare parts are charged import duties and value-added taxes (VAT), which is a major constraint for the importers and local manufacturers. The local manufacturers are also facing problems with continuous electricity supply, limited access to training and bank loans, credit facilities with higher interest rates, etc. Therefore, the import of agricultural machinery and spare parts should be exempted from import duties and taxes. The VAT imposed on the stages of production and sales of agricultural machinery should also be withdrawn for widespread distribution and adoption of new technologies.

### **Employment and Labour Productivity**

Rapid urbanization has greatly reduced agricultural and natural areas, causing migration of rural population to urban areas. This population movement to urban areas reduces labour productivity in agricultural areas (Ergen, 2016). Agriculture of Bangladesh is facing labour scarcity in recent years due to labour migration in urban areas seeking better employment opportunities. The migration of this labour has led to labour shortages, causing higher agricultural labour wages.

Wage rates have been rising in

urban areas which also encouraging this rural-urban migration. The rising wage helps to reduce rural poverty but creates labour shortages in rural areas (Wang et al., 2016). This labour shortage has negatively affected farm profits and productivity. Statistics show that the labour force employed in on-farm agricultural activities would reduce from 43% to 36.1% by 2020 and to 20% by 2030, posing an emerging challenge to the agriculture of Bangladesh (Alam and Khan, 2017b). Therefore, appropriate scale mechanization for agricultural operations would be the key factor in facing this challenge.

On the other hand, the government should support the research and development programs on manufacturing small tools, equipment, and machinery in rural areas. This will help to reduce poverty and generate employment in rural areas and could promote sustainable agricultural mechanization. Further, the repair and maintenance services provided by the engineering workshops and custom hiring of agricultural machinery could also generate more employment in the rural areas. Therefore, Bangladesh's government should focus on rural poverty reduction and employment generation for the successful adoption of mechanized farming.

### Custom Hiring Services

The labour shortage and rising wages in rural areas have created the condition of using agricultural machinery, helping to avail mechanization services to smallholder farmers (Islam, 2018). These benefits could be increased by providing custom hire services of agricultural machinery to the smallholder farmers.

Small-scale machinery is appropriate as the farm sizes of Bangladesh are small; hence smallholder farmers own small agricultural machinery and rent-out their services to other farmers for additional earnings (Rahman et al., 2013; Baudron

et al., 2015; Aryal et al., 2019). In contrast to the developing countries with larger-sized agricultural farms, very few smallholder farmers invest in agricultural machinery in Bangladesh. Therefore, the promotion of agricultural mechanization to the smallholder farmers could be enhanced by increasing access to agricultural machinery through custom hire services (Biggs and Justice, 2015).

Rising demand for agricultural machinery has produced in comparatively well-developed markets for custom-hire services for tillage, irrigation, and postharvest operations (Mottaleb et al., 2016). Recently, among the popular agricultural machinery, combine harvester has got wider acceptability by the farmers for paddy harvesting on custom hiring due to labor shortage and timeliness of harvest. Maize shellers have also gained popularity for custom hire services. Similarly, the owners of many agricultural machinery and equipment such as power tillers, irrigation pumps, sprayers, paddy threshers were renting out their machinery to other farmers and became economically stable.

The growth of the agricultural machinery custom hire service is one of the major developments in Bangladesh's agricultural mechanization. Machinery owners provide business services to the other farmers. The advanced agricultural machinery is available to the farmers in recent years but the rate of machinery adoption is quite low. Mechanization through custom hire services could enhance the adoption of these new technologies. In the near future, the demand for custom hire services of agricultural machinery for threshing, harvesting, and drying of cereal crops will be higher to the farmers who cannot afford to buy these machinery. Therefore, public-private sectors should focus on the development of custom hire services of these machines that can be highly beneficial to the farmers

and would enhance the likelihood of agricultural machinery adoption.

The successful implementation of mechanized agriculture can bring opportunities to the rural area by creating employment in machinery operation, transportation, repair and maintenance, agricultural machinery rental services, etc., can effectively contribute to achieving SDG.

## Adoption of Modern Technologies for Sustainable Agriculture

### Status of Smart Farming Technologies

Smart farming comprises the integration of modern technologies into traditional cultivation practices in order to enhance farming efficiency and to produce high-quality agricultural products. Interest in smart farming technologies is increasing widely for maximizing agricultural production and minimizing environmental pollution (Sung, 2018).

The application of advanced technologies to agriculture could be the key driving force for enhancing crop productivity and promoting agricultural development. However, efforts have been made to introduce new advanced machinery to stimulate more precision to Bangladesh agriculture such as seeders, reapers, and conservation agriculture machines, i.e., zero-till planter, strip-tillage planter, and bed planters but widespread adoption of these modern machines are still to be achieved (iDE, 2012). Among the factors, better education and training to farmers, easily available credit facilities, and sharing of information would facilitate the adoption of these advanced agricultural systems (Saiz-Rubio and Rovira-Más, 2020).

Improving farm production is one of the major challenges that need to be focused in the coming decades. Smart farming technologies can improve agricultural efficiency and play a vital role in feeding the

country's growing population by reducing inputs, optimizing outputs, and reducing postharvest losses as possible. Therefore, the adoption of smart farming technologies can contribute to meet the increasing food demand and can contribute to sustainable farm production. The quality and quantity of agricultural production can be increased by promoting smart farming technologies, which will lead to sustainable mechanized farming to achieve SDG.

### **Opportunity and Challenges of Smart Farming in Bangladesh**

In recent times, agriculture has been entering the fourth revolution regarding the increasing use of information and communication technology (ICT) (Walter et al., 2017). Autonomous and robotic farm vehicles have been developed for different farming purposes like mechanical ploughing, planting and weeding, application of fertilizer, herbicide and pesticide, and harvesting of cereal and fruits. Besides, the development of automated unmanned aerial vehicles (UAV) (Floreato and Wood, 2015) coupled with the hyperspectral cameras have been used to measure the growth of biomass and fertilization status of crops (Li et al., 2014; Bareth et al., 2015), which provides the real field scenarios for advising precise farm management among farmers. Moreover, several models are now available to help farmers characterize plant diseases regarding optical information (Wahabzada et al., 2016). On the others, virtual fence technologies (Umstatter, 2011) is used to manage cattle herd based on remote-sensing signals and actuators or sensors linked to the livestock. Together using these smart technologies are generating ample changes in agricultural farming in developed countries as well as starting in developing countries, where the expansion of ICT are being received at a fast pace and could be used for seasonal drought forecasts

and climate-smart agriculture in the future (Walter et al., 2017). Such profound changes in agricultural practices called smart farming give not only ample opportunities but also big challenges, particularly in the Bangladesh context.

#### ***i. Opportunities Created by Smart Farming***

Firstly, smart farming lessens the ecological footprint of farming. The application of fertilizer and pesticide inputs can be reduced in the precision agricultural system, which will minimize leaching problems and greenhouse gas emissions (Schulze et al., 2009). With the use of ICT, it is possible to build a sensor network that will allow for continuous agricultural farms monitoring. Likewise, theoretical and practical knowledge on the states of plants, soils, and animals with the desired production inputs like water, fertilizer, and medications are reaching with using that ICT globally. Secondly, smart farming can create agriculture more profitable for farmers by minimizing the input resources such as labours and money and producing reliable, spatially explicit data that will decrease any risks during production. Optimal site-specific weather forecasts, yield projections, and probability maps for disasters and diseases regarding a profound network of climate and weather data or GIS and remoting sensing will authorize the cultivation of the crops optimally. Similarly, automated sensors can record all farming-related information, minimizing the time required for prioritizing the application of input resources and administrative surveillance. Sensors integrated with agricultural machinery such as tractor, transplanter, and combine harvester can also log the field information (such as soil moisture or soil electrical conductivity (EC) during tilling and crop moisture and protein content harvesting) in real-time that helps the farmers to make

the decision quickly. Finally, smart farming also has the potential for the betterment of consumer acceptance by improving the management of product quality, and these products become healthier and sell at higher prices (DeFries et al., 2015). Moreover, the transparency about production and processing will exacerbate the value chain of products because ICT permits registration where the farm produces certain products under some circumstances. This provides the potential more for the direct interaction among farmers and consumers (Walter et al., 2017).

#### ***ii. Challenges to Smart Technology Adoption***

Connectivity and awareness- The first challenge is the lack of connectivity which inhibits farmers' ability to take merits of new innovation and smart technologies. According to BTRC (2019), there is currently 98.14 million internet subscribers presence in Bangladesh, among which 92.36% have access the internet through the mobile device. However, no appropriate data have in our hands regarding how many farmers use smart devices and how many of them use or can use those devices for agricultural purposes. Smart devices are mostly in the hands of urban middle-income people that must be reached to every rural farmer; otherwise, proper achievement using this technology will not be possible. The second one is the lack of awareness among rural farmers. Interestingly, we have no statistical data on how many farmers know about the internet of things (IoT), information and communication technology (ICT) and smart technology. Application of such technologies, particularly in the context of Bangladesh's effects on crop diversity, but small land or fragmented landholding is more challenging rather than use in a large and mono-crop farm. In addition, such types of technology and devices need especial consideration for both manufacturer and main-

tenance regarding cost factors. In farming conditions, there are no two cases identical, and in agronomical fields, the cost of hardware and software maintenance is guessed to be higher than usual as those devices that are exposed to harsh environments such as wind, storm, flood, cold and physical damage.

Knowledgeable and skilled human resource-Illiterate people are a big challenge for adopting smart agriculture. Nearly about 26% of adult people are still illiterate (BBS 2018), mostly in rural areas and can not contribute to developing agriculture. Always, they want to use their previous experiences or forefather experience for entire agriculture operation and production. Besides, educated youngers are not feeling interested in agriculture in order to non-profitable and social status among other businesses and jobs. In addition, uneducated people are also not capable of analyzing the amount of data generated from such smart devices. Therefore, knowledgeable and skilled people is essential in data science. Regarding these circumstances, we have to depend on our universities to empower the strength to produce such type of human resource.

Technical failure and network compatibility-Sometimes, the growing dependence of technology on agriculture has potential damage during production. If any mechanical breakdown or malfunction happens in the hardware, sensors, and farming IoT, serious crop damage can result in the absence of skilled technical experts available in rural areas. Besides, a proper network is very important for using smart devices. Interestingly according to the newspaper (Islam, 2020), mobile network is slowest in Bangladesh among 42 countries in the world. Especially in rural areas, there is a big problem with using a mobile network or wireless network for information sharing among farmers or sensors communication with any

automated devices. In addition, data package for internet is not cheap for the users, that's why the government has to ensure or subsidy regarding that issue. Otherwise, smart technology or smart farming will not come up with our expectations, and the desired product will not happen.

Individual zones management-Traditionally, farmers in the country have a habit of taking their entire fields as single farming units, and that approach is not very much workable for the IoT application and management in agriculture. For this reason, farmers or users can portion their lands into different smaller management zones concerning the soil sampling requirements (individual zones have unequal soil qualities) and fertilizer requirements, but a lot of confusion arises about the correct size of that zones. In addition, the number of zones and their respective sizes on a field depends on the overall size of the growing area. There are no enough available reference works or literature for the farmers by which their lands can try to divide into these zones. In an alternative way, some farmers lead to apply recommended fertilizer application or irrigation methods for their entire field when sub-optimal results happen.

However, the use of smart technologies has also started in Bangladesh even though there are some challenges to adopt these ones. Especially dairy and livestock farms in the country have begun to smart with the use of IoT services. Recently, Digi Cow and Shurjomukhi Pranisheba have started to provide IoT services to livestock with the help of Grameenphone, and besides, Dutch Dairy Ltd was established a year and a half years ago where smart and digital technologies are being implemented successfully. In addition, modern technologies such as Recirculated Aquaculture System (RAS) and Biofloc have also been introduced in fish farming in Bangladesh, like the expansion of verti-

cal and soilless farming methods. Besides, in food processing industries, smart technologies can also precisely measure the food quality and grade the agricultural produce. Now entrepreneurs and educated farmers are much more motivated and optimistic about using digital and smart technology. Therefore, it is expected that within few years, Government and private sectors will come to incorporate smart technologies such as IoT and artificial intelligence in agriculture for precise operation and management, which also helps for attaining SDGs in the country.

## Challenges and Prospects of Sustainable Agricultural Mechanization

### Problems of Mechanization Adoption due to Farm Size and Fragmented Land

When a household has cultivated a piece of possessed or hired non-continuous lands, it is called land fragmentation (Wu et al., 2005). It is also an average land-sized reducing process and, at the same time, increasing the scattering of household land and decreasing the size of the individual plots on a farm (Agarwal, 1971). The presence of small and fragmented lands is a key factor in the low development rate of agricultural mechanization systems. If the cultivatable lands are fragmented and located long distances from the owner's house and each other, it increases transport costs. Moreover, management, supervision, and securing small plots are also more difficult, time-consuming, and costly. Small and scattered plots and wasteland areas require boundary land for fencing, border construction, and paths and roads. Also, small and fragmented land restricts the farmers to use a larger size of farm machinery. About 84.39% of the rural households are small having 50-249 decimals of land (BBS, 2017) and

even this small landholding is fragmented into several plots, make the efficient use of small and medium-size PTs, tractors, transplanter, reapers, mini-combine harvesters and other machinery difficult and lead to the problem of frequent turning and make the operation time-consuming, tedious and expensive (Alam and Khan, 2017b; Islam, 2018).

#### **Accessibility of Mechanization to Smallholder Farmers**

The farmers accessed the agricultural machinery that may have been cost-prohibitive to purchase through fee-for-service arrangements. In this regard, the accessibility of agricultural machinery in scale-appropriate is needed to more consider along with buy and service provision effectively for the marginal farmers (Hossain, 2009). At present, 80 percent of cropland is prepared by PTs, which is estimated at half a million (BBS, 2011, Ahmmed, 2014; iDE, 2012). It is a remarkable development in land-prepared operation that, on average, each PT owner can cultivate 11-15 ha of land, and Bangladesh is only 0.59 ha given the average farm size. In general, the marginal farmers are resource-poor concerning low incomes that carried out the low demand for agricultural machinery, resulting in land and labor productivity remain at low levels. Simultaneously, the parallel cycle of pressure on natural resources led to the lucky end and enhanced the farmers' poverty level (Twomlow, 2002). A more positive cycle of events may take place when the demand for mechanization inputs is increased. Then, the improved productivity will increase compared with levels of savings, which will lead to more demand for productivity-enhancing inputs, including agricultural mechanization. The poverty cycle can be broken, and improved livelihoods occur when the challenge is to get sustainable mechanization, which is available for elements to smallholder

agriculture, not just in agricultural production but also in the supply and value chain. It also improves the timeliness of farming operations, which reduces drudgery and minimizes the load on women, the elderly, and children. Nevertheless, there is no consent on how best to involve smallholder farms into mechanization systems and ensure open access to use farm machinery by resource-poor farm households. Due to lacking sufficient capital of farmers for actual machinery buying for service provision and fee-for-use models, extend machinery access. Such concern is crucial for promoting appropriate farm machinery within South Asia and other developing countries.

#### **Prospects for Private-Sector Promotion of Mechanization**

The private sector covering individual farmers, small enterprises, and large companies are working to popularise the agricultural machinery in Bangladesh as a result of machinery is available to marginal farmers. However, there is a huge discrepancy in the whole mechanization process in Bangladesh, and it is inevitable to involve the private sector in agricultural mechanization to be sustainable in future food production. While private investment is very prospective in mechanization, the private entrepreneur still hardly comes into this sector. A number of reasons could be stated for this reason. Firstly, there is no evidence available about prospects, problems and scope due to lack of data and thorough research. Private investors don't see it as lucrative as other sectors. Secondly, there is no enough incentive and promotion from the government as with other sectors. A lack of a strong insurance policy could be another reason. Thirdly, the design and manufacturing of agricultural machinery are very intricate and sometimes universal design could not be enough as some machinery performance depends on local agricultural input features.

Therefore, the private sector can play an important role in mechanization by manufacturing tools or machine parts rather than importing these from other countries with a high payment of tax. If the companies start to manufacture the machinery parts, then they can sell the machinery at a low price. The Metal Group has set up sales and service centers for modern agro-machinery in each of the Upazila's of that district. Farmers buying machinery from those centers are enjoying subsidies (it addresses their capital deficit). These types of machinery are manufactured or imported by considering the realities of Bangladesh. Also, the government is needed to play a greater role in promoting the private sector by generating and providing the public goods that are urgently needed. The government can create an enabling environment through necessary policies such as exchange rate, agricultural product prices, agricultural input prices i.e., tariffs and input restriction and input subsidies, and farm power research policy, such as machinery research and agricultural sustainability. Also, it is needed to introduce some laws and regulation which will protect consumers. This should include consumer information services, introduction and enforcement of standard of machinery, etc. Only then will the private sector come forward to invest in agriculture. Demonstration of the full range of machinery on the market could also help correct for the distortions introduced by subsidies or concessional loans that limited farmers' exposure to certain brands, assuming supporting supply chains for spare parts and repairs could also be developed. However, this is an area where empirical evidence is scarce. It should not be simply assumed that many farmers are unaware of the benefits of various modes of mechanization. More pilot studies combined with rigorous assessments may be needed to see when demand for

mechanization can be stimulated by informing farmers of the potential benefits. Likewise, it remains to be seen whether the financing provided by dealers and manufacturers will be successful in the long run. The private sector enhances to attain SDGs when effective coordination should be ensured in the field level with non-governmental agricultural machinery manufacturers and research institutes for innovation and development as well as identify the manufacturing industry for selected technologies. Also, the government should introduce some laws and regulation which will protect consumers. This should include consumer information services, introduction and enforcement of standard of machinery, etc. Only then will the private sector come forward to invest in agriculture. The implementation of the agricultural credit policy formulated by the central bank needs to be further improved.

#### **Research on Mechanization Demand and Adoption**

The organization related the agricultural machinery development would be strengthening research to the extent based on the nature of mechanization adoption by the farmers in Bangladesh. The demand for agricultural machinery is often quite localized, based on crops and soil conditions. For example, the hoar area in Bangladesh is needed to the large tractor and combine harvester during the Boro paddy harvesting. In contrast, the northern part of the country is required the reaper to harvest the wheat. The existing data are not rich or specific enough to make useful inferences on where and which agricultural machinery is most feasible. It is necessary to intensify research to better understand the nature of the demand for agricultural machinery services based on different farming systems, labor dynamics, and socio-economic factors. In that case GIS tool may be used for mapping

particular areas on the basis of low, medium and high lands, ponds, canals, rivers, commercial areas, residential area, etc. so that it will be possible to find out the accessibility of agricultural machinery and its demand in the particular areas. USAID funded ASMIH-Bangladesh project is doing similar works in limited scale in their project sites. The governments can overcome the lack of data by conducting agricultural machinery surveys that fully capture the dynamics of equipment ownership, use, crop, and service provision across different regions of the country. The soil maps can also be produced, which will provide information on the types of agricultural machinery demanded and needed to urgent adoption. It can help identify appropriate agricultural machines and prioritize the mechanization areas to be pursued as well as research and adoption of agricultural machinery where population and market dynamics have made the mechanization feasible.

#### **Conclusions**

In alignment with Sustainable Development Goals (SDGs), present status, challenges, and opportunities of agricultural mechanization in Bangladesh have been discussed in the study. The history of agricultural mechanization to the launching smart farming systems in Bangladesh has also been presented in the article. Bangladesh is conscientiously working on SDGs to achieve targets by 2030. Agriculture and rural development are directly concerned with attaining food security and promote sustainable agriculture which is one of the goals of SDGs. Agricultural mechanization has several benefits including rural development based on the utilization of modern machines in agriculture. Rural development and sustainable agriculture might be enhanced national GDP and ultimately

assist in achieving SDGs. Under these circumstances mentioned in the article, the implementation of a recently approved national agricultural mechanization policy in alignment with SDGs is urgently needed for increasing the crop productivity and economic emancipation in Bangladesh. Finally, we suggest what governments of developing countries like Bangladesh should take initiatives on mechanization related activities for achieving SDGs are as follows: Government of Bangladesh should pay more attention to take appropriate measure for modern machinery extension services in the field; create employment opportunity of skilled human resources in the field level; need to allow duty-free and VAT-free import opportunity of farm machines and spare parts; need an arrangement of close monitoring of repair & maintenance scheduling of farm machines for sustainable use of field level machines and need especial focuses on research and development for continuous enhancement of agricultural mechanization and smart farming systems in alignment with SDGs. To boost up agriculture development and continuous contribution to national GDP for attaining SDGs, agriculture should be mechanized and commercialized with modern machines and technologies in Bangladesh.

**Author Contributions:** All co-authors contributed equally to all phases of the elaboration of the paper.

#### **REFERENCES**

- Agarwal, S. K. 1971. Economics of land consolidation in India. S. Chand & Co. (Pvt.) Ltd. New Delhi, India.
- Ahmed, S. 2014. Country presentation paper, Bangladesh. The 10th session of the Technical Committee of CSAM and Regional Workshop on Establishing

- a regional database of agricultural mechanization in Asia and the Pacific, Siem Reap, Cambodia. Available from: <http://un-csam.org/ppta/201411TC10/BD.pdf>
- Bareth, G., Aasen, H., Bendig, J. and Soukkamäki, J. 2015. Low-weight and UAV-based hyperspectral full-frame cameras for monitoring crops: Spectral comparison with portable spectroradiometer measurements. *Photogrammetrie, Fernerkundung, Geoinformation*, 1: 69-79.
- Alam, M. M., Khan, M. I. N., Saha, C. K., Rahman, A. and Bhuyian, M. G. K. 2017. Manufacturing of agricultural machinery in Bangladesh: opportunities and constraints. *Agricultural Engineering International: CIGR Journal*, 19(1): 122-135.
- Alam, M. M. and Khan, I. N. 2017a. Status of agricultural machinery manufacturing in Bangladesh. In: Mandal, M. A. S., Biggs, S. D. and Justice, S. E. (eds.), *Rural mechanisation: A driver in agricultural change and rural development*. Institute for Inclusive Finance and Development (InM), Dhaka, Bangladesh, pp153-176.
- Alam, M. M. and Khan, I. N. 2017b. Agricultural mechanization: Status, challenges and opportunities in Bangladesh. In: Gurung, T. R., Kabir, W. and Bokhtiar, S. M. (eds.), *Mechanization for sustainable agricultural intensification in SAARC Region*. SAARC Agriculture Centre, Dhaka, Bangladesh. pp41-70. Available from: <http://www.sac.org.bd/archives/publications/Mechanization%20for%20Sustainable%20Agricultural%20Intensification.pdf>
- Ali, R. 2020. GPS and GIS: future of precision agriculture. <https://www.daily-sun.com/post/494019/GPS-and-GIS:-Future-of%20Precision-Agriculture> (cited on 17 July 2020).
- Animaw, A. T., Nkanya, J. A. M., Nyakiba, J. M., Woldemariam, T. H. and Takeshima, H. 2016. Agricultural mechanization and south-south knowledge exchange: What can Ethiopian and Kenyan policy-makers learn from Bangladesh's experience? ESSP Research Note 47, Addis Ababa, Ethiopia: International Food Policy Research Institute.
- Aryal, J. P., Rahut, D. B., Maharjan, S. and Erenstein, O. 2019. Understanding factors associated with agricultural mechanization: A Bangladesh case. *World Development Perspectives*. 13: 1-9.
- Baudron, F., Sims, B., Justice, S., Kahan, D. G., Rose, R., Mkomwa, S., Kaumbutho, P., Sariah, J., Nazare, R., Moges, G. and Gérard, B. 2015. Re-examining appropriate mechanization in Eastern and Southern Africa: two-wheel tractors, conservation agriculture, and private sector involvement. *Food Security*. 7:889-904.
- BBS. 2011. *Statistical Yearbook of Bangladesh*. Bangladesh Bureau of Statistics, Ministry of Planning, Government of the People's Republic of Bangladesh.
- BBS. 2017. *Statistical Yearbook of Bangladesh*. Bangladesh Bureau of Statistics, Ministry of Planning, Government of the People's Republic of Bangladesh.
- BBS. 2018. *Statistical Yearbook of Bangladesh*. Bangladesh Bureau of Statistics, Ministry of Planning, Government of the People's Republic of Bangladesh.
- BBS. 2020. *Statistical Yearbook of Bangladesh*. Bangladesh Bureau of Statistics, Ministry of Planning, Government of the People's Republic of Bangladesh.
- Biggs, S. and Justice, S. 2015. Rural and agricultural mechanization: A history of the spread of small engines in selected Asian countries IFPRI Discussion Paper 1443. Washington, D.C.: International Food Policy Research Institute (IFPRI). Available from URL: <http://ebrary.ifpri.org/utils/getfile/collection/p15738coll2/id/129214/filename/129425.pdf>.
- BTRC. 2019. Internet subscribers in Bangladesh. August. <http://www.btrc.gov.bd/content/internet-subscribers-bangladesh-august-2019> (cited on 17 July, 2020).
- DeFries, R., Fanzo, J., Remans, R., Palm, C., Wood, S. and Anderman, T. L. 2015. Metrics for land-scarce agriculture. *Science*, 349(6245): 238-240.
- Ergen, M. 2016. Relationship between population and agricultural land in Amasya, In: *Urban Agriculture*, Samer, M. (Ed.). IntechOpen, pp. 89-99. DOI: 10.5772/62402. Available from: <https://www.intechopen.com/books/urban-agriculture/relationship-between-population-and-agricultural-land-in-amasya>.
- Floreato, D. and Wood, R. J. 2015. Science, technology and the future of small autonomous drones. *Nature*, 521: 460-466.
- Gurung, T. R., Kabir, W. and Bokhtiar, S. M. 2017. Mechanization for sustainable agricultural intensification in SAARC region SAARC Agriculture Centre, Dhaka, Bangladesh. pp316. Available from: <http://www.sac.org.bd/archives/publications/Mechanization%20for%20Sustainable%20Agricultural%20Intensification.pdf>
- Hossain, M. 2009. The Impact of Shallow Tube Wells and Boro Rice on Food Security in Bangladesh. IFPRI Discussion Paper 00917, International Food Policy Research Institute (IFPRI), Washington D.C, USA. Available from: <http://ebrary.ifpri.org/utils/getfile/collection/p15738coll2/id/29565/filename/29566.pdf>
- Hossen, M. A. 2019. Mechanization in Bangladesh: Way of modernization in agriculture. *International Journal of Engineering Trends and Technology*, 67(9):69-77.
- iDE. 2012. Study into the commercialization of selected agricultural machines in Bangladesh. *International Development Enterprises (iDE)*, Dhaka, Bangladesh. Available from: <http://www.ide.org.bd/publications/Commercialization%20of%20Selected%20Agricultural%20Machines%20in%20Bangladesh.pdf>

- able from: <https://repository.cimmyt.org/xmlui/bitstream/handle/10883/3394/98527.pdf>.
- Islam, D. M. S. 2009. Farm mechanisation for sustainable agriculture in Bangladesh: problems and prospects. <http://un-csam.org/Activities%20Files/A09105thTC/PPT/bd-doc.pdf> (cited on 15 July 2020).
- Islam, A. and Kabir, M. 2017. Rental service market of farm machinery in rice cultivation: A farm level investigation. *Bangladesh Rice Journal*, 21(1):35-45.
- Islam, A. K. M. S. 2018. Status of rice farming mechanization in Bangladesh. *Journal of Bioscience and Agriculture Research*, 17(1): 1386-1395.
- Islam, M. Z. 2020. Mobile internet slowest in Bangladesh among 42 countries. <https://www.thedailystar.net/business/news/mobile-internet-slowest-bangladesh-among-42-countries-1892761> (cited on 17 August, 2020).
- Justice, S. and Biggs, S. 2013. Rural and agricultural mechanization in Bangladesh and Nepal: Status, processes and outcomes. In: Kienzle, J., J. E. Ashburner and B. G. Sims (eds.), *Mechanization for rural development: A review of patterns and progress from around the world*. Food and Agriculture Organization of the United Nations (UNFAO), Rome, pp.67-98.
- Kienzle, J., Ashburner, J. E. and Sims, B. G. 2013. *Mechanization for rural development: a review of patterns and progress from around the world*. Food and Agriculture Organization of the United Nations (FAO), Rome. Available from: <http://www.fao.org/3/i3259e/i3259e.pdf>.
- Li, F., Mistele, B., Hu, Y., Chen, X. and Schmidhalter, U. 2014. Reflectance estimation of canopy nitrogen content in winter wheat using optimised hyperspectral spectral indices and partial least squares regression. *Euro J Agron*, 52: 198-209.
- MOA. 2016. *Agricultural mechanization road map 2021, 2031, 2041*. Ministry of Agriculture, People's Republic of Bangladesh, Dhaka.
- Mottaleb, K. A., Krupnik, T. J. and Erenstein, O. 2016. Factors associated with small-scale agricultural machinery adoption in Bangladesh: Census findings. *Journal of Rural Studies*. 46: 155-168.
- Parvez, S. and Byron, R. K. 2020. Farm mechanisation gets a big push from govt. <https://www.thedailystar.net/business/news/farm-mechanisation-gets-big-push-govt-1930645> (cited on 15 July 2020).
- Rahman, A., Latifunnahar, M. and Alam, M. M. 2013. Financial management for custom hire service of tractor in Bangladesh. *International Journal of Agricultural and Biological Engineering*. 6(3): 28-33.
- Saiz-Rubio, V., Rovira-Más, F. 2020. From smart farming towards agriculture 5.0: A review on crop data management. *Agronomy*. 10, 207.
- Schulze, E. D., Luyssaert, S., Ciais, P., Freibauer, A., Janssens, I. A., Soussana, J. F., Smith, P., Grace, J., Levin, I., Thiruchittampalam, B. and Heimann, M. 2009. Importance of methane and nitrous oxide for Europe's terrestrial greenhouse-gas balance. *Nature Geoscience*, 2(12): 842- 850.
- Seraj, S. 2020. Agricultural machinery: Where is Bangladesh heading? <https://www.thedailystar.net/country/news/agricultural-machinery-where-bangladesh-heading-1927969> (cited on 10 July 2020).
- Sung, J. 2018. The fourth industrial revolution and precision agriculture. In: Hussmann, S. (ed.), *Automation in Agriculture: Securing food supplies for future generations*. Intechopen: London, UK, pp3-15.
- Tiwari, P. S., Gurung, T. R., Sahni, R. K. and Kumar, V. 2017. Agricultural mechanization trends in SAARC region. In: Gurung, T. R., Kabir, W. and S. M. Bokhtiar, S. M. (eds.). *Mechanization for sustainable agricultural intensification in SAARC Region*. SAARC Agriculture Centre, Dhaka, Bangladesh. pp1-40. Available from: <http://www.sac.org.bd/archives/publications/Mechanization%20for%20Sustainable%20Agricultural%20Intensification.pdf>
- Twomlow, S., O'Neill, D., Sims, B., Ellis-Jones, J. and Jafry, T. 2002. An engineering perspective on sustainable small holder farming in developing countries. *Biosyst. Eng.*, 81: 355-362.
- Turton, C. and Afsar, R. 2002. Livelihood and farm power- The RE-FPI experience. The IDL Group, P.O. Box 20. Somerset, TA 18 7YW, UK.
- Umstatter, C. 2011. The evolution of virtual fences: A review. *Comput Electron Agric*, 75: 10-22.
- Wahabzada, M., Mahlein, A. K., Bauchhage, C., Steiner, U., Oerke, E. C. and Kersting, K. 2016. Plant phenotyping using probabilistic topic models: uncovering the hyperspectral language of plants. *Scientific reports*, 6(1): 1-11.
- Walter, A., Finger, R., Huber, R. and Buchmann, N. 2017. Opinion: Smart farming is key to developing sustainable agriculture. *Proceedings of the National Academy of Sciences*, 114(24): 6148-6150.
- Wang, X., Yamauchi, F., Otsuka, K. and Huang, J. 2016. Wage growth, landholding, and mechanization in Chinese agriculture, *World Development*. 86: 30-45.
- Wu, Z., Liu, M. and Davis, J. 2005. Land consolidation and productivity in Chinese household crop production. *China Economic Review*, 16:28-49.

■ ■



# The Regional Network for Agricultural Machinery



by

Reynaldo M. Lantin

Former Information Officer of ESCAP/RNAM  
Retired Professor and Former Dean,  
College of Engineering and Agro-industrial Technology,  
University of the Philippines Los Baños  
PHILIPPINES  
reylantin@gmail.com

## Abstract

The Regional Network for Agricultural Machinery or RNAM was a UNDP-supported project initially by eight Asian countries comprising India, Indonesia, Islamic Republic of Iran, Pakistan, Philippines, Republic of Korea, Sri Lanka and Thailand. Bangladesh and Nepal joined in 1987, China in 1990 and Vietnam in 1994. The participating countries performed sub-program activities through their designated National Institutes and which were highlighted by exchanges of information and of machinery prototypes.

The RNAM project was executed by the UN ESCAP in association with FAO, UNIDO and with technical collaboration with IRRI. Apart from UNDP, funds also came from Australia, Japan and the participating countries. The inter-country project based on the concept of a network started operations in 1977 through a Regional Office hosted by the Government of the Philippines at the University of the Philippines Los Baños until 1991 (Phases 1-4) when the UNDP support ended, then at the ESCAP headquarters in Bangkok, Thailand until 2002 (Phase 5) with support from donor countries.

The participating countries benefited from the exchanges of information, face-to-face interactions in various regional and in-country meetings, training courses, work-

shops, study tours and machinery exhibitions. The perceived ripple effects of RNAM towards establishing similar inter-country projects in Latin America and Africa had been initiated by international agencies to promote technical cooperation among developing countries with a view to achieving the MDGs. Perhaps because of today's more modern communications like online video meetings, e-publishing, etc. using the internet and of lesser operational costs than before, reviving such initiatives would faster achieve even more benefits than had been previously available to the participating countries and RNAM.

**Keywords:** RNAM, regional network, inter-country project, information exchange, agricultural machinery, agricultural mechanization strategies, ripple effect, technical cooperation

## Introduction

Agricultural mechanization has been a controversial issue in developing countries in spite of the belief among policy makers that modernization of farming operations is the key to higher production and productivity. The issues frequently discussed in mechanization forums and meetings among engineers, economists and sociologists have contributed to the better understand-

ing of the complexities in achieving mechanization levels higher than manual and animal power technologies. Participants in such conferences have realized that mechanization is more than just the introduction and use of modern powered machinery in a milieu of small farm holdings, poverty in the rural areas, farm employment and inadequate social and technical preparation for the technologies beyond manual and animal power levels.

The issues on sociological and economic aspects consist of displacement of labor, high investment and operational costs, non-conclusive evidence on increasing crop yields, insufficient knowledge and due diligence in the proper operation, care and maintenance of power units and implements as well as non-appreciation of the benefits of agricultural mechanization by some decision makers in government.

Recent industrial developments in the Asian economies have led to the increasing scarcity of farm labor. The favored non-farm employment and higher educational attainment by the youth take away their interests in farming. Through time, because of parceling out the farmer's already small and uneconomical size of the farm land to the children who, because of limited knowledge in agriculture use the traditional methods handed down to them, worsen the low returns from farm-

ing and have resulted in idle lands and their conversions into non-agricultural uses. Unfavorable political decisions on policies have had telling effects in the low productivity and low production and need to be corrected through sound analysis by those in the know.

In general, the higher level of mechanization using mechanical or non-muscle-powered agricultural machinery is beginning to be the new normal in developing countries. Consolidating lands (Japan pioneered in this because of the realization of the increasing uneconomically viable small farms vis-a-vis the developments) or clustering the small farm areas is an option to achieve economies of scale in the higher levels of mechanization.

Appropriate strategies need to be formulated in agricultural methods to strike sustainable and affordable mechanization. Rijk (1989) raised a point that instead of rice transplanting, direct seeding where feasible would be simpler, less laborious and less costly to mechanize such as by using a manually pulled or power tiller-drawn drum seeder than rice transplanting using a manually operated rice transplanter or perhaps even a tractor-operated one. The issues of acceptability of the new method and the implications on requirements of related operations such as thorough land preparation (or alternatives yet to be developed) and control of weeds and pests (rodents, snails and birds) as well as proper water control have to be considered.

Alternative methods to have checkrow transplanting advantages may also be achieved in direct seeding through precision seeding equipment, which give an added advantage of less seed requirement making it economical to plant the costly but productive hybrid seeds (Regalado et al., 2013). Nevertheless, broadcast seeding, the easiest, fastest and most economical method (the trade-off is the cost of extra amount of seeds) has been long-time practiced is some

areas like the Western Visayas in the Philippines. Yet, broadcast seeding to achieve at least row planting in contrast to random seeding could still be improved. (Kassama, 1999) devised a method of planting juvenile seedlings by hill-drop broadcast planting.

Getting the farmers' experiences and developing an institutional infrastructure towards exchanging of information would be helpful; hence, the need for a network of information exchange at the national level. Similarly, information on techniques from the rice-producing countries in Asia would be helpful if a regional network of information exchange would be institutionalized through a project.

### The RNAM Story – Excerpts from the RNAM Newsletter No. 58 – April 1998

“The Regional Network for Agricultural Machinery (RNAM) has its origin in the former Asian Industrial Development Council (AIDC) which studied the agricultural machinery industry sector from 1968 to 1972 and identified the need for a

regional institutional arrangement. UNDP sponsored missions to India, Indonesia, Islamic Republic of Iran, Pakistan, Philippines, Republic of Korea, Sri Lanka and Thailand which resulted in an agreement to create a network of National Institutes to provide close collaboration and extensive exchange of information on various aspects of agricultural mechanization under the coordination of a Regional Office. Bangladesh and Nepal joined RNAM in 1987, China in 1990 and Vietnam in 1994.

The National Institutes in the participating countries are to be strengthened by RNAM to increase their capabilities in organizing and implementing the country programs. The programs cover of design and development, testing and evaluation, manufacture and popularization of improved agricultural machinery.

Thus, RNAM became the first UNDP-assisted inter-country project based on the concept of a network. It began operations in 1977 with the support of UNDP which designated the United Nations Economic and Social Commission for Asia and the Pacific (ESCAP) as

Figure The RNAM network system

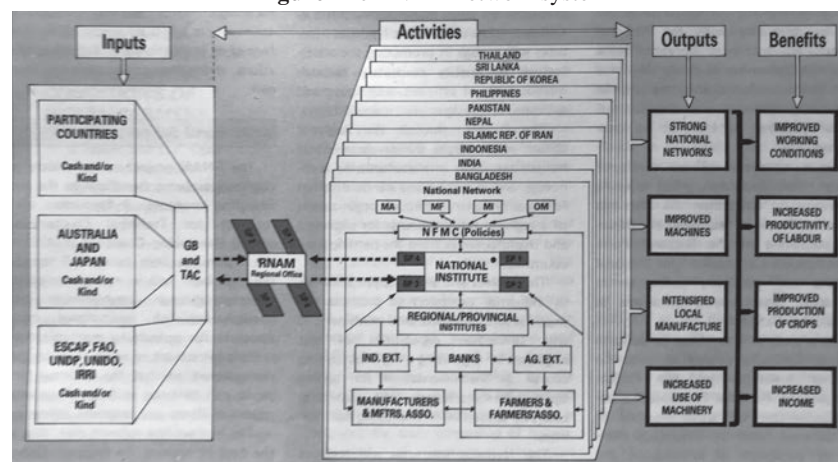

**Key:**

- AG - Agricultural
- ASSO - Associations
- EXT - Extension
- GB - Governing Body
- IND - Industrial
- MA - Ministry of Agriculture
- MF - Ministry of Finance

- MFTRs - Manufactures
- MI - Ministry of Industry
- NFMC - National Farm Mechanization Committee
- OM - Other Ministries Involved
- SP - Subprogramme
- TAC - Technical Advisory Committee

•Two-way linkage exist between countries and RNAM, and among countries

the Executing Agency in association with the Food and Agriculture Organization (FAO) and the United Nations Industrial Development Organization (UNIDO). The organization and operating system of RNAM are depicted in the **Figure** (ESCAP/RNAM, 1987). The technical collaboration of the International Rice Research Institute (IRRI) in Los Baños, Philippines was also enlisted. UNDP assistance to the Project ended in 1991. Funds for RNAM now come from donor countries, Australia, Belgium, Germany, Japan and the Netherlands as well as from the participating countries.

The Regional Office was moved from Los Baños, Philippines to ESCAP Headquarters, Bangkok, Thailand and started operations from there with effect from 1<sup>st</sup> January 1992.”

RNAM expanded its scope as the Regional Network for Agricultural Engineering and Machinery (RNAEM).

Since 2003 RNAM has evolved further into United Nations Asian and Pacific Center for Agricultural Engineering and Machinery (UN-APCAEM) and later into the present Center for Sustainable Agricultural Mechanization (CSAM), with headquarters in Beijing, China.

### The Five Phases of RNAM (1977-2002)

During the first four phases with the Regional Office (RO) in Los Baños, Philippines, the RNAM project enabled the PCs to exchange information and experiences in agricultural machinery and mechanization through implementation of work programmes formulated by the Technical Advisory Committee (TAC) of which the heads of the NIs, which were the focal points in each country, participated in the annual review and planning together with representatives of UNDP, ESCAP, FAO, UNIDO, IRRI and

the Governments of Australia and Japan.

A Governing Body (GB) composed of higher-level government representatives from each country, the international organizations and the donor countries, reviewed the work programmes discussed in the TAC meeting and the proposed budget.

On the one hand, the RO handled the regional activities such as the inter-country training courses, seminars, workshops, study tours, catalytic assistance in exchanges of information and machinery prototypes as well as in the holding of agricultural machinery exhibitions. These regional activities were in accordance with the planned sub-programmes (SPs) supported by funds as well as technical and administrative advice.

On the other hand, the NIs implemented their own country programs in their own National Network (NN) adapted from the Sub-programmes (SPs) as well as the inter-country participation for the activities in SPs.

In operation, the GB approved the work plan before the start of the succeeding phase as shown for example, by topics of the SPs in the following work plan for the Second Phase (1982-1984):

- SP1. Establishment and strengthening of NNs;
- SP2. Strengthening of design capability;
- SP3. Testing, evaluation and modification of machinery;
- SP4. Promotion of local manufacturing;
- SP5. Popularization of improved implements and machinery; and
- SP6. Information dissemination.

The work plan for the Fourth Phase (1987-1991) consisted of the following:

- SP1. Formulation and implementation of appropriate agricultural mechanization policies and strategies;
- SP2. Design and development of

- selected agricultural machinery;
- SP3. Local manufacture of selected agricultural machinery; and
- SP4. Extension of appropriate agricultural mechanization technology.

During its meeting in the Republic of Korea in 1990, the GB approved the recommendation of TAC that RNAM provide catalytic assistance to the PCs beyond 1991 in the following areas and in their order of priority based on the effectiveness of the NIs rather than on the importance of the activities in the overall mechanization programme. Nevertheless, the priorities of the NIs should be kept in mind by indicating flexibility in the programme formulation.

The work plan for the Fifth Phase (Beyond, 1991) consisted of the following:

- SP1. Extension of agricultural machines (market expansion) through demonstrations in farmers' fields;
- SP2. Manufacture of agricultural machines through sharing of technologies and joint venture/licensing agreements;
- SP3. Design and development of appropriate agricultural machines through exchange of information and hardware;
- SP4. Integration of women in agricultural mechanization activities; and
- SP5. Strategies for appropriate agricultural mechanization.

### Agricultural Mechanization Policies and Strategies

The formulation of agricultural mechanization strategies had been one of the continuing major activities of RNAM. Early on, RNAM through ESCAP contracted two consultants to produce guidelines for developing strategies with specific application to the member countries after a survey of the mechanization situations in such countries. A set of

recommendations was given in the “Guidelines for Agricultural Mechanization Strategy in Development” (Gifford and Rijk, 1980).

As sequel, based on the experiences gained, several scholarly articles about agricultural mechanization strategies such those in India, Indonesia and Thailand and including those by FAO were published. FAO produced a publication on agricultural mechanization in development: guidelines for strategy formulation (FAO, 1981) which may be adapted by developing countries.

One of the impacts of the RNAM project was the positive response of all the PCs to RNAM’s advocacy for formulating strategies for agricultural mechanization, a significant activity which had been previously lacking or set aside in most of the

PCs, except for the Republic of Korea which started its planning activities for mechanization during the early 1960s. This could be a reason for the Republic of Korea’s advancement in agricultural mechanization among the PCs.

The institutional mechanism for the formulation of policies and strategies for agricultural mechanization was the National Farm Mechanization Committee (NFMC) which was essentially an advisory body to the government planning agency and is chaired normally by a ranking official from the ministry of agriculture. The equivalent of NFMC may be called differently among the PCs and preferably should have such status level within the government hierarchy as to enable it “to influence planners and policy makers on the

totality of development issues related to agricultural mechanization.” The multi-disciplinary and multi-agency composition of the NFMC has created awareness for strategy formulation.

In the Philippines, the mechanism for NFMC started in 1980 with the organization of the Agricultural Mechanization Inter-agency Committee or AMIC, which was then encumbered by being an ad hoc one awaiting formal approval and without operating budget. Nevertheless, AMIC created awareness of the importance of the formulation of policies and strategies for agricultural mechanization. AMIC was later proposed to be transformed into the National Agricultural Mechanization Council but it has been superseded by the Philippine

**Table 1** General mechanization policy directions in the PCs as of December 1986

From \ To	India	Indonesia	Nepal	Pakistan	Philippines	Sri Lanka	Thailand
India		Agricultural waste fuelled dryer	CIAE dhal mill	CIAE dhal mill (0) Air screen grain cleaner	Low-cost multi-purpose grain mill Air screen grain cleander Agricultural waste fuelled dryer Paddy winnower Wet and dry grind machines Four roller sugarcane crusher	Low-cost multi-purpose grain mill	Low-cost multi-purpose grain mill CIAE dhal mill
Indonesia	Corn sheller (powered and manual)				Folder power thresher		
Nepal		Rice milling M/C (a) compact unit (b) de-husker (c) brown rice polisher Water turbine					
Pakistan		2-3 meter reaper winnower			Village level flour mill		
Philippines	IRRI experimental rubber roll single pass rice mill IRRI pre-dryer UPLB improved village rice mill Batch type polygonal dryer Motor driven peanut sheller	IRRI pre-dryer UPLB improved village rice mill Manual peanut sheller Motor driven peanut sheller Cassava chipper IRRI conical type weeder	UPLB improved village rice mill	Paddy continuous flow dryer Motor driven peanut sheller		Paddy circulation dryer IRRI experimental steel roll single pass rice mill	Paddy circulation dryer Paddy continuous flow dryer High capacity corn sheller
Sri Lanka	Fluidized bed dryer	Fluidized bed dryer			Fluidized bed dryer		Fluidized bed dryer
Thailand	Village rice mill				Village rice mill Cashew nut sheller		

Council for Agriculture and Fisheries (PCAF). The current (2020) institution performing the NFMC task under PCAF is the Bureau of Agricultural and Fisheries Engineering (BAFE) of the Department of Agriculture (DA), which heads the National Banner Program Committee for Agricultural and Fisheries Mechanization (NBPCAFM). For the first time, the program has been allocated a budget for preparing and implementing an updated roadmap for agricultural mechanization.

The task of the NFMC was the formulation of strategy according to the policies laid down by the national planning body pertaining to agriculture and issues related to agricultural mechanization. The unified and integrated plan or strategy was aimed at a systematic handling of agricultural mechanization, which when handled on isolated project-to-project basis, tended to be

non-cohesive and to lack of the desired efficiency and effectiveness in achieving development objectives.

RNAM/ESCAP, along with FAO, provided the PCs with guidelines for the formulation of strategies conforming to existing policies or recommending appropriate policies. It organized a regional workshop and a regional training course on the subject in which government planners and agricultural engineers from the NIs participated.

Through RNAM's advocacy activities, decision makers in the PCs have become aware of the role of agricultural mechanization as a strategy for development, an issue which used to be relegated to the background in national government plans. Many developing countries came to realize that they had been spending large amounts of foreign exchange in importing machineries which were not as efficiently uti-

lized by their local farmers as those in the countries of origin or developed countries. Investments would be rationalized through following of guidelines in formulating strategies to avoid further inefficiencies or costly mistakes. **Table 1** shows the general policy directions in the PCs as of the end of 1986.

Each PC had its own unique agricultural technical, sociological and economic conditions that a single formula was not possible. Thus, the matter of planning to consider all aspects of agricultural mechanization was the major task of the NFMC. RNAM recommended the involvement of government agencies and instrumentalities as well as the private sector concerned to have a comprehensive and effective agricultural mechanization roadmap.

Indeed in 1987, RNAM organized a regional training workshop on formulation of policies and strategies

**Table 2** Human resources development in RNAM

	India	Indonesia	Islamic Rep. of Iran	Pakistan	Philippines	Rep. of Korea	Sri Lanka	Thailand	Total
<b>Regional Training Courses</b>									
Policies and Strategies	2	2			2	2	2	2	12
Testing and Evaluation	2	7	2	3	4	2	2	4	26
Design and Development	4	3	3	5	4	6	5	5	35
Manufacturing Technology	3	3		3	3		2	3	17
Industrial Extension	2	2	1		2	2	2	2	13
<b>Total</b>	<b>13</b>	<b>17</b>	<b>6</b>	<b>11</b>	<b>15</b>	<b>12</b>	<b>13</b>	<b>16</b>	<b>103</b>
<b>Regional Workshop</b>									
Weeders	1	5			2	1	3	2	14
Rice Transplanters	2	1	2	2	3	2	1	1	14
Cereal Harvesters	3	2	1	2	3	2		2	15
Manufacturing Technology	3	7	3	7	6	5	7	7	45
Standardization of Agricultural Machinery and Equipment	2	1			2	1	1	2	9
Testing, Evaluation and Modification of Prototypes and Testing Technology of Agricultural Machinery	2	2	2	2	2	3	2	3	18
Agricultural Mechanization Planning, Policies and Strategies		1	1	1	1	2	1	1	8
Extension and Popularization of Agricultural Machinery	4	2		2	2	2	2	2	16
Mnufacturing and Popularization of Agricultural Machinery	1	1		1	1	1	1	1	7
<b>Total</b>	<b>18</b>	<b>22</b>	<b>9</b>	<b>17</b>	<b>22</b>	<b>19</b>	<b>18</b>	<b>21</b>	<b>146</b>
<b>Study Tours</b>									
Research and development in design and testing of agricultural machinery	3	1		1	2	2	1	2	12
Selection of agricultural machinery	1	1		1	1	1		1	6
<b>Total</b>	<b>4</b>	<b>2</b>		<b>2</b>	<b>3</b>	<b>3</b>	<b>1</b>	<b>3</b>	<b>18</b>

for agricultural mechanization in the Republic of Korea which along with India at the time had given adequate attention to the mechanization component of the development plan and had followed planning procedures which were conducive to the adequate consideration of the mechanization component. Only in Korea was mechanization an element which was considered when developing other sectoral plans and when integrating the agricultural sector plan into the overall National Development Plan. It was deemed proper to revisit past planning efforts and reactivate the NFMC in the country if it had not already done so in the light of current developments.

### Strengthening the Capabilities of National Institutes (NIs)

RNAM organized regional training courses and workshops on policies and strategies, design, manufacturing technology, industrial extension, standardization, popularization of agricultural machinery and sponsored individual and group training fellowships with travel to donor countries. Those trained in turn conducted local courses and seminars as well as mentoring activities for the NI staff and the cooperating machinery fabricators, thereby achieving multiplier effects. The human resources development has been a continuing process in the NIs. **Table 2** indicates the number of trained engineers/technical staff in each PC during 1978-1986 (ES-CAP/RNAM, 1987).

The RNAM operational activities that were implemented through the sub-networks, farm mechanization studies, training programmes, information dissemination and other programmes had impact on the PCs.

During the First Phase (1977-1981), there were subsets of PCs, which were engaged in sub-network

activities for testing, evaluation and adaptation of rice transplanters, weeders and cereal harvesters, the prototypes of which they have selected. These sub-network activities provided opportunities for face-to-face interactions and mutual learning in the same area of interest, thus, strengthening the capabilities of the NI design engineers.

The RO assisted them by identifying suitable prototypes of the machine existing at the time. For example in the sub-network activity on rice transplanters, of which the Philippine NI was the coordinator and the participating NIs were Pakistan and Sri Lanka, the manually operated rice transplanter from IRRI was chosen over the commercial prototypes from non-PCs after field testing and evaluation in each participating NI. The choice also considered the PC's capacity for local manufacture and availability of manpower for field operation for which training would be imperative. In this regard, IRRI itself provided technical assistance through its country rice R & D projects, which were relevant to rice transplanters.

For example, IRRI conducted pilot project activities in Libmanan, Camarines Sur, Philippines where a farmer co-operator readily adopted the IRRI rice transplanter because of its labor-saving advantage but later abandoned its adoption because of his concern for displacing some of his farm workers in rice transplanting. They were his mainstay in providing labor not only in transplanting but also in weeding and harvesting.

The case was similar in certain aspects to the "perfected yet rejected" machine (Starkey, 1988) because the technology might be ahead of its time when labor displacement would be a prime consideration.

In Sri Lanka however, where the farm labor was scarcer than in the Philippines at the time, farmers readily adopted the IRRI rice transplanting technology with ad-

aptations consisting of simplified seedling growing and slightly modified designs to suit local fabrication techniques. The IRRI R & D collaborative project in Sri Lanka played a role in the local modification of rice transplanter based on local conditions. Moreover, it was supported by commercial local manufacture and after-sales services directly by the fabricators.

Currently however, reintroducing the IRRI rice transplanter in some parts of the Philippines might be appropriate because manual transplanting labor has gotten scarce and tractor-operated mechanical transplanters are not affordable or custom-hire services are not available. Because of labor shortage, some rice farmers might inevitably quit planting rice with repercussions on food security. A pro-active NFMC and timely formulated strategies would timely address the emerging problem.

For example, the decision for a mix of levels of technology for rice transplanting that is, by hand, by locally manufactured manually operated transplanter or by imported powered rice transplanters could as well be an issue in the planning for mechanization in specific locations by the NFMC. Consideration may also be given to alternatives to rice transplanting such as direct seeding but will pre-require improved land preparation, better water control and timeliness and post-require better weed control methods. The decision to adopt rice transplanting or direct seeding or a mix of the two as the field, weather and labor supply conditions arise impacts on increasing productivity and income of farmers as well as food security.

The delivery of mechanization technologies will consider among other factors and requirements, getting foreign investors in setting up powered machinery manufacturing plants, to import with certain regulations or to locally mass manufacture the IRRI rice transplanter

by modern methods. Using the cut-and-weld fabrication technology does not ensure standardization and complementation of parts unless standard jigs and fixtures are used. Besides the fabrication skills tend to be lost due to ageing or retiring of machinery shop workers. The decision will be just one aspect of agricultural mechanization policy and strategy needing attention and study by the NFMC in the face of looming food (meaning rice supply) insecurity amid the Covid-19 pandemic scourge or other future calamity.

### Exchanges of Information and Machinery

The rationale behind the network concept is to enable each PC in the network, with unique mechaniza-

tion development history and status, to share its experiences and lessons learned for the benefit of other PCs.

Apart from the information exchanges, the countries also benefited from the direct exchanges of machinery prototypes based on the requests and needs of a country and the availability of such technologies in another country. The objective was to fast track the development of such machines in the recipient country since much R & D efforts had already been made in the source country. The exchanges were realized through the facilities provided by UNDP and ESCAP as regards to clearing from customs duties. The responses of the PCs in such exchanges are shown in **Table 3**, which resulted from a regional workshop on design of drying and milling equipment held at the NI in

the Philippines in November 1987.

Both the donor and the recipient countries benefited from the test and evaluation results as well as the modifications for improvement made on the machine by the recipient country. This ideal situation did not come out as much as what was the desired outcome. After doing some work on a donated machine, some NIs abandoned the effort after finding some problems and deficiencies during the test and evaluation activities under local conditions. The support to the NI by the government's GB representative to RNAM was therefore, crucial.

This observation was similar to the farmers' reaction when given machines by the government for field trials. When the farmer finds the machine not to perform as expected during initial trial, he is

**Table 3** Planned exchanges of engineering drawings of drying and milling equipment among the participating countries as of the end of 1987

India	<ul style="list-style-type: none"> <li>• Use of higher levels.</li> <li>• Use of higher levels of mechanization (engine powered) which would increase cropping in intensity to increase income of farmers.</li> </ul>
Indonesia	<ul style="list-style-type: none"> <li>• Mechanization to be supported by making available appropriate, efficient and low-cost machinery.</li> <li>• Introduction of higher levels of production technology to transmigration areas.</li> <li>• Mechanization requirements in Java to focus on post-harvest handling, processing, irrigation and pest control.</li> </ul>
Islamic Rep. of Iran	<ul style="list-style-type: none"> <li>• Shift from oil-based to diversified economy.</li> <li>• Appropriate levels of mechanization to be promoted to enhance productivity, production and farmers' income.</li> <li>• Local manufactures to be encouraged to achieve self-sufficiency to the maximum extent possible; importing of components not considered viable.</li> <li>• Increase mechanization power level to 0.9 hp/ha during the next 10 years; yield of wheat to be 3,000 kg/ha.</li> </ul>
Pakistan	<ul style="list-style-type: none"> <li>• Phasing out of bullock-based farming in favour of powered farming using tractors which will be manufactured locally.</li> <li>• Greater participation by the private sector in development will be encouraged.</li> <li>• Custom hiring of all types of machinery will be encouraged.</li> </ul>
Philippines	<ul style="list-style-type: none"> <li>• Mechanization that promotes optimum use of labour of increases productivity rather than displaces labour, to be developed and encouraged.</li> <li>• Local production of appropriate farm tools and equipment to be supported.</li> <li>• Agro-based employment opportunities among the rural population, particularly the landless worker, to be created/increased.</li> <li>• Post-harvest technology to be development.</li> </ul>
Rep. of Korea	<ul style="list-style-type: none"> <li>• Mechanization to be promoted to alleviate farm labour shortage while ensuring maximum and economic utilization of agricultural machinery.</li> <li>• Supply of good quality machinery to be extended.</li> <li>• After-sales services to be strengthened.</li> <li>• Training facilities and farmers' training to be expanded.</li> </ul>
Sri Lanka	<ul style="list-style-type: none"> <li>• Mechanization of non-irrigated and rainfed areas for increased crop production and productivity to be emphasized.</li> <li>• Import policy to exclude undesirable imports of agricultural machinery.</li> <li>• Labour-saving devices, not to displaces labour, to be promoted.</li> </ul>
Thailand	<ul style="list-style-type: none"> <li>• Agricultural production efficiency to be increase.</li> <li>• Unit production cost to be competitive in foreign markets.</li> <li>• Farm mechanization policy to be included in 6th Plan for National Economic and Social Development, 1987-1991.</li> <li>• Master plan for rationalizing mechanization system to be drafted.</li> </ul>

inclined to reject it outright perhaps because of lack of familiarity with the technology. Ideally, the cooperating farmer should have been selected based on interest and innovative ability to do modifications on the machine. In hindsight, it would be helpful if the field trial were done through the farmers' and manufacturers' associations.

The usual players in the agricultural mechanization milieu are the R&D institutions engaged in agricultural machinery and mechanization, the agricultural machinery fabricators and manufacturers, the relevant NGOs and the government implementing agencies mandated to increase yields and productivity in agriculture, on the one hand, and the policy and decision makers in government, on the other hand.

On the management of the programs, GB, in its session in November 1981, took note of that the RO had taken appropriate action on its previous recommendations on (i) indicators of progress; (ii) inclusion of reports on training in the RNAM Newsletter; (iii) periodic census of agricultural machinery; (iv) study of socio-economic and safety aspects of agricultural mechanization; evaluation of training; (v) unutilized fellowships; (vi) group training in the Netherlands; and (vii) training on the vertical straw conveying rice reaper design, operation and maintenance by a visiting team from China. The GB also recommended that the RO undertake the evaluation of RNAM training programmes and the evaluation of progress of RNAM activities in terms of agreed indicators.

It was noted that China had been very active in sending representatives as observers in the TAC and GB sessions and showed keen interest in the RNAM project. Its representatives reiterated their Government's desire for strengthened co-operation. China's interests and desires would later be reflected in its hosting of study tours, group

training and other RNAM activities in the later phases of RNAM, in its joining RNAM in 1990 and its hosting of the evolved RNAM (UNAP-CAEM/CSAM) starting in 2003.

The highlights of the program for Phase 2 according to the project document approved by UNDP as proposed by the TAC and endorsed by the GB in their sessions in July 1981 were as follows:

The basic objectives of developing agricultural mechanization in the Asian region, that is, raising agricultural productivity and incomes of small farmers, would continue with overriding priority over other objectives.

The strategy to achieve these objectives through mechanization consisted of vigorously pursuing the supply of appropriated agricultural machinery for adaptation, transfer of appropriate technology, local manufacture, popularization of successful machinery, technical co-operation between developing countries (TCDC) for training and information dissemination.

RNAM as early as in Phase 1, emphasized the necessity of establishing and strengthening institutional mechanisms such as the National Farm Mechanization Committees (NFMCs) and NNs for spearheading the formulation of mechanization strategies as well as the effective coordination and implementation of programs within the PCs (ESCAP/RNAM, 1981).

During the intergovernmental meeting on agro-industries in Tokyo from 21 to 22 October 1980, where representatives of Australia, Bangladesh, Bhutan, Burma, Democratic Kampuchea, India, Indonesia, Japan, Malaysia, Maldives, Nepal, the Netherlands, New Zealand, the Philippines, Republic of Korea, Thailand, US, and USSR and consultative capacity of the Federal Republic of Germany, the Executive Secretary of ESCAP noted that RNAM during its past four years of operation, had demonstrated the

usefulness of the network approach and the successful operation of the sub-network activities. Besides the technical aspects of design and development, the project was engaged in assisting the countries in the establishment of NFMCs for consideration of policy issues; dissemination of information on technological and manufacturing developments through newsletters, technical digests and manuals and the provision of extension communication and training facilities.

## RNAM Publications

The RNAM Newsletter, which was issued every April, August, and December of each year started in 1978, provided a chronicle of its organization and establishment, the significant development events concerning RNAM such as its inception, approval by ESCAP of the project documents for each of the four phases, the TAC and GB meetings and the expansion into RNAEM. It also chronicled the activities such as those of regional workshops on four major sub-network activities, group training courses, study tours as well as country activities regarding holding of NFMC meetings, promotion of tested and modified machinery including those exchanged between countries, summarized progress of countries in agricultural mechanization such as establishment of database, etc. as well as the results and outputs of such activities.

The RNAM Newsletter also reported news and developments in agricultural engineering and technology in the PCs and other countries. Some articles written by experts in agricultural mechanization were also presented. All in all, the newsletter performed also the major task of information dissemination which was a critical and significant activity in the network concept.

The value of the newsletter could be achieved however, if the PCs



would make follow-up inquiries from the source NI or PC regarding the details of the technology presented. Chances were that the same type of technologies was being developed in one country and much could be learned from communicating about the problems encountered one-on-one basis. This was the intent of the network. In post-RNAM, the Newsletter would be an adjunct link among the PCs apart from the yearly or face-to-face meetings in workshops, training courses and administrative meetings of the TAC of UNAPCAEM. The Newsletter would be extremely helpful and best if its publication is continued if only to take advantage of the momentum already gained during the RNAM and RNAEM years.

The e-Newsletter, which put out its maiden issue in both hard and soft copies on 1 November 2006, has essentially replaced the RNAM Newsletter but the readership becomes limited to those who have access to the internet. After all, the same focal institutions or NIs in RNAM are also involved in the UNAPCAEM and currently CSAM.

Other publications by RNAM consisted of the following:

1. A brochure on the Regional Network for Agricultural Machinery;
2. Thailand' harvest? man or machine? by Jack Makeham, February 1979;
3. Digest 1 – Rice transplanter, April 1979;
4. Lack of agricultural mechanization: causes and effects, by Ghulam Kibria, October 1979;
5. Aspects of appropriate agricultural mechanization development priorities, by Adrianus G. Rijk, November 1979;
6. Regional catalogue of agricultural implements, January 1980;
7. A reaper for Thailand?, by Jack Makeham, May 1980;
8. Regional Network for Agricultural Machinery Progress Review, A detailed review, June 1980;
9. Report of the UNDP Review

- Mission – RNAM (RAS/76/013) by Charles J. Moss and David W. Gaiser, 15 August 1980;
10. Guidelines for agricultural mechanization strategy in development by R. C. Gifford and A. G. Rijk, October 1980;
  11. Digest 2 – Power tiller, December 1980;
  12. Digest 3 – Power units, May 1981; Technical circulars, total 32;
  13. Testing, evaluation and modification of weeders, 1983
  14. Testing, evaluation and modification of rice transplanters, 1983
  15. Testing, evaluation and modification of cereal harvesters, 1983
  16. Test codes and procedures for selected common agricultural machinery:
    - a. Part 1. Ploughs;
    - b. Part 3. Disc harrows;
    - c. Part 4. Seeding equipment with or without fertilizing attachment;
    - d. Part 5. Rice transplanters;
    - e. Part 6. Row-crop cultivators;
    - f. Part 7. Weeders;
    - g. Part 8. Liquid herbicide applicators;
    - h. Part 9. Hand-operated shoulder and knapsack sprayers;
    - i. Part 10. Hand rotary dusters;
    - j. Part 11. Harvesting machines;
    - k. Part 12. Power grain threshers;
    - l. Part 13. Peanut shellers;
    - m. Part 14. Manually-operated pumps;
    - n. Part 15. Power-operated pumps;
    - o. Part 16. Batch rice driers;
    - p. Part 17. Continuous-flow rice driers;
    - q. Part 18. Rice mills;
  17. Workshop layout for safe and efficient production, 1987;
  18. Workshop safety manual, 1987
  19. Success cases of popularization of selected agricultural machinery, 1987
  20. Policies and strategies on agricultural mechanization in the RNAM PCs, 1987;
  21. Revised RNAM Brochure, 1990;
  22. Design and data handbook for

- agricultural machinery, 1990;
23. Agricultural machinery design and data handbook (seeders and planters), 1991
  24. Regional catalogue of agricultural machinery, 1991.
  25. Existing policies and strategies for agricultural mechanization in RNAM PCs, 1993
  26. The publication consisted of those for ploughs, disc harrows, seeding equipment with or without fertilizing attachment, rice transplanters, row-crop cultivators, weeders, liquid herbicide applicators, hand-operated shoulder and knapsack sprayers, hand rotary dusters, harvesting machines, power grain threshers, peanut shellers, manually-operated pumps, power-operated pumps, batch rice driers, continuous-flow driers. Other publications consisted of workshop safety manual and success cases of popularization of selected agricultural machinery.

## Industrial extension

Khan (1991), former head of the Agricultural Engineering Division of IRRI and who simplified the design of the power tiller and developed the axial-flow thresher for local manufacture by small- and medium-scale machinery fabricators, suggested the “commercial approach to machinery development” for adoption by public research institutions to have relevance in the sustainable supply of appropriate and useful agricultural machines to farmers.

He also noted that the traditional institutional approach had not been effective because of the research institution's mandate to produce new knowledge to satisfy academic requirements and curiosity with little regard to applications in the field although such applicability was not entirely ignored. The application thrust usually conflicted with the agenda of producing a new design

as dictated by the institutional mandate and by the personal interest of the researcher in achieving and showing performance in the short term.

Thus, it was not surprising that the engineering research institutions become archives of designs for design sake and museum of machine prototypes which never got to be commercially produced and used by farmers. Such outputs however, could be sources of ideas in a public-private partnership program wherein the public research institution works with creative and innovative private manufacturers and mutually enforce one another in achieving the best machinery product that is functional and efficient as well as satisfies farmers' needs.

The public engineering research institution is usually mandated to help the government in formulating strategies in conformity with government policies. When the relevant strategy, activities and implementing rules and regulations are approved and made public for transparency, the research institution may proceed without apprehension in dealing with the private agricultural manufacturers as partners in design, development and commercialization of the machines developed to the point of farmers' acceptability, affordability, durability and other desired features for successful commercialization of the machine. Together they can work in synergy towards developing the right machinery technologies which are acceptable to the farmers.

On the one hand, the entrepreneurial machinery fabricator or manufacturer may be a creative and innovative engineer himself and has a cadre of selected well-qualified shop technicians. The entrepreneur should have the capacity to sustain even a modest design and development project, which may not be revenue-making in the short-term but because of his/her experience in marketing among farmers has the

gut feeling of success. The strength of the research institution is in professional engineering design capabilities of the staff and the approach for the interest of the public, especially the farmers rather than the profit motive. The institution however, is normally weak in the commercial aspects that will finally get their outputs in the hands of farmers and other users.

On the other hand, almost the opposite attitude and capability occurs in the private manufacturer's side especially in developing countries and understandably so because as stakeholder, his/her aim is the protection of investment. The profit-making motive and the risks involved make the activities focused on short-term goals and investments in design and development and long-term ones may be far from the agenda of a fledgling manufacturing enterprise.

Thus, from the public point of view the program satisfies a mandated requirement to be of service to farmers and from the private enterprise point of view the program meets the goal of making profit through commercial sales of machinery. However, this strategy appears not to have taken root among the supposed partners in machinery design, development and commercialization mostly because it needs drastic changes from the rigid government accounting and auditing procedures to the more flexible budgeting of the private sector. Besides, the question of misappropriation of public funds for partnership with a particular manufacturer is always in the minds of intrigue makers and engineering staff in the public institution tend to shy away from any activity that may tarnish their professional and public service integrity. The research institution would be wary of the risks to reputation in handling public funds and would like itself to be freed from protests and intrigues sown by disfavored manufacturers.

An instrument that may avoid such intrigues and encourage the engineers and the institution to engage in partnership is to select the manufacturer partner through public bidding for transparency and prevention of anomaly in favoring a certain manufacturer who will be at an advantage. Another method is to do it through an association of manufacturers so that the deal is institutional rather than individual.

The research institutions in Thailand and the Republic of Korea have adopted the above strategy and have made progress in the machinery manufacturing and supply industry either through their own government initiatives or with confirmation of their approach through participation in RNAM which has been advocating such approach. Nevertheless, it is informative to make case studies of the two countries specifically of their experiences in overcoming constraints, encouraging the private manufacturers to be cooperators or partners with the research institution and avoiding possible intrigues. Other developing countries may adopt the successful approach if solutions to potential problems were made first as shown by the two countries' experiences and adopted strategies.

On the technical side, Thailand presents a model of private sector rather than research institution initiative. One innovative but practical rice combine manufacturer who has obtained an engineering degree from the Philippines, embarked on the ambitious design and development of the rice combine. His major motivator was his vision of Thailand becoming one of the major exporters of quality rice. His initial models of the rice combine were crude- and monstrous-looking typical of design and development process where the initial aim was functionality to satisfy the need, which he previously studied rather than industrial design for its salability. He adapted the axial-flow thresher design from

IRRI for the threshing and cleaning unit. He also adapted, using locally available materials, the usual western combine design for the track-type support and propelling unit, the header and the cut materials conveying unit as well as the bagging and the later the bulk handling unit for the threshed and cleaned paddy. It took him quite a while to make a “perfect” design as he went through the process of field test and evaluation and gathering feedback from cooperating and non-cooperating (having hostile attitudes) farmers, government officials, economists, laborers and international visitors. When he saw the light at the end of the tunnel and needed refinements in design, he consulted the engineering research institution engaged in R&D of agricultural machinery.

Periodic meetings between research, design and development institutions in India have been held since at least in 1979 to develop closer contacts between the manufacturers, extension workers and the design institutes. Field demonstrations and exhibitions of agricultural implements in the villages under actual farming conditions was emphasized for increasing awareness and demand for implements. These meetings revealed that most of the small-scale manufacturers lacked technical know-how in streamlining production and the NI could take steps in assisting them. This status of small-scale manufacturers has been true for all the RNAM PCs and appropriate actions have been taken to address their problems.

### Ripple Effect of RNAM

The following is an excerpt from Chapter 16 of the book entitled “Mechanization for Rural Development,” published by the FAO Integrated Crop Management (Lantin, 2013).

“Perceived as RNAM’s ripple effect, there have been initiatives of

some international development agencies in establishing regional networks in Latin America and East Africa (ESCAP/RNAM, 1986). The United Kingdom’s Overseas Development Administration and the British Council convened a conference in Vera Cruz, Mexico in 1986 to promote the formation of the Latin American Regional Network for Small Farm Mechanization aimed at increasing technical cooperation among Latin American countries and other regions in the aspects of agricultural engineering for the small farmer. Representatives from 14 Latin American countries as well as from France, UK, and Switzerland participated in the conference (SARH, 1986).

“Another indication of the ripple effect of RNAM was the initiative of FAO and ILO in East Africa. They conducted a joint inter-agency mission in Botswana, as preparatory work for the establishment of the African Network for Agricultural Tools and Equipment.”

In the UGEXPO, an international exposition organized by the Belgian Federation of Agricultural Machinery and Horticultural Equipment and held in Brussels, Belgium in 1990, the idea of initiating and creating a Euro-African Network for Agricultural Machinery based on a similar concept of RNAM was discussed among the delegates of 18 countries in Africa.

### Conclusions

It took nine years for RNAM to be realized in 1977 from an initial study in 1968. Perhaps the initial interests in creating RNAM-type collaboration in the Latin American and African regions could be revived in the light of the success of RNAM in Asia, its evolution into the Center for Sustainable Agricultural Mechanization, the continuing concern for food security among developing countries and a com-

mitment to achieve the Millennium Development Goals of the UN. Given the modern communication technologies, the formation of such a Network and the implementation of activities would be easier and faster than that of RNAM.

As variant, a parallel inter-regional network between Africa and Asia would be beneficial as the lessons achieved in RNAM could be beneficial to a similar network in Africa. For example, by institutional arrangements, information on improved hand tool and animal-draft implement technologies developed in the RNAM PCs could be made available for trial under local conditions by the R&D institutions in the African countries.

### REFERENCES

- ESCAP/RNAM. 1978-1991. RNAM Newsletter issues No. 1-39. UN Economic and Social Commission for Asia and the Pacific/Regional Network for Agricultural Machinery.
- [Copies of the RNAM Newsletter may be available at the libraries of each National Institute of the RNAM participating countries].
- ESCAP/RNAM. 1981. TAC and GB approve Second Phase plan. RNAM Newsletter. No. 12, December. UN Economic and Social Commission for Asia and the Pacific/Regional Network for Agricultural Machinery.
- ESCAP/RNAM. 1986. Policy and strategy directions for agricultural mechanization in RNAM participating countries. RNAM Newsletter. No. 27, December. UN Economic and Social Commission for Asia and the Pacific/Regional Network for Agricultural Machinery.
- ESCAP/RNAM. 1987. RNAM in Fourth Phase (1987-1991). RNAM Newsletter. No. 28, April. UN Economic and Social Commission for Asia and the Pacific/Regional Network for Agricultural Machinery.

- ESCAP/RNAM. 1987. Update on RNAM human resources development. RNAM Newsletter. No. 28, April. UN Economic and Social Commission for Asia and the Pacific/Regional Network for Agricultural Machinery.
- ESCAP/RNAM. 1987. RNAM organizes two regional workshops on machinery design. RNAM Newsletter. No. 30, December. UN Economic and Social Commission for Asia and the Pacific/Regional Network for Agricultural Machinery.
- FAO. 1997. Agricultural mechanization strategy preparation: A guide. Agricultural Engineering Service. Rome, Italy.  
[*“The Agricultural Engineering Service of The Food and Agriculture Organization of the United Nations has extensive experience on the topic and undertaken several strategy studies in developing countries, as well as in Eastern Europe. The AGSE is the principle and unique source for information and assistance on AMS. Earlier publications from AGSE on AMS followed a central planning approach to mechanization, focused on the collection of detailed information while the policy environment were considered exogenous and to be taken into account, rather than emphasizing the need for policy reform. This approach is now considered obsolete and not to be pursued. This new AGSE Bulletin reflects the latest thinking of the Agricultural Engineering Service of FAO on the formulation of an agricultural mechanization strategy. It is a manual prescribing the various steps and requirements to assist those who are involved in actual strategy formulation work. It incorporates the experiences obtained with formulation of agricultural mechanization strategy.”*]
- Gifford, R. C. and Rijkm, A. G. 1980. Guidelines for Agricultural Mechanization Strategy in Development. Report to the Economic and Social Commission for Asia and the Pacific/Regional Network for Agricultural Machinery.
- Kassama, Lamin S. 1999. Hill-drop broadcast planting of juvenile seedlings for crop establishment of irrigated rice (*Oryza sativa*, L.). Unpublished MSc. Thesis. University of the Philippines Los Banos, College, Laguna, Philippines.
- Khan, A. U. 1992. Critical issues in transferring agricultural mechanization technologies in the developing world. *Agricultural Engineering Journal* 1(2): 105-141.
- Lantin, Reynaldo M. 2013. Information exchange and networking: the RNAM experience. In: *Mechanization for Rural Development*. Kienzle, Josef, Ashburner, John E. and Sims Brian, G. Eds., FAO Integrated Crop Management Vol. 20-2013.
- Regalado, Manuel C., Eulito U. Bautista, Caesar Joventino M. Tado, Eden C Gagelonia, Emmanuel V. Sicat, George Canapi and Joel Panagsagan. 2013. Mechanization of land preparation and crop establishment operations in rice farming in the Philippines. In: *Mechanization in Rice Farming*. Papers presented at the Annual Rice Forum “Mechanization in Rice Farming: Status, Challenges, and Opportunities.” Banta, Stephen J., Ed., 22 November. BSWM Auditorium, Quezon City, Philippines.
- Rijk, A. G. 1989. *Agricultural Mechanization Policy and Strategy*. Asian Productivity Organization, Tokyo, Japan  
[*“This book deals with definitions, terminology, and concepts on agricultural mechanization strategy formulation. It provides for a comprehensive review of the agricultural mechanization process and addresses important developmental issues of mechanization in relation to crop production, farm family income, employment, social change, transfer of mechanization technology, and fossil energy consumption. It discusses the need for mechanization policy and strategy, its place in the agricultural planning process, and provides for general policy and strategy guidelines. As a case study the book addresses agricultural mechanization in Thailand and describes a computer model which was used for analyses on mechanization policy and strategy in Thailand. The book contains an extensive list of relevant literature.”*]
- SARH. 1986. Memoria: Conferencia sobre la formación de una red de mecanización Agrícola para la pequeño agricultor. Campo Experimental Cotaxtla. Veracruz, México. Secretaría de Agricultura y Recursos Hidráulicos, Instituto Nacional de Investigaciones Forestales y Agropecuarias, 523 p. ■■

# Agricultural Mechanization Today in Indonesia in Relation to the SDGs



by  
Kamaruddin Abdullah  
The Graduate School,  
Renewable Energy Engineering Program of Study,  
Darma Persada University  
Jl. Radin Inten II, Pondok Kelapa, East Jakarta, 13450  
INDONESIA

## Introduction

On the occasion of the anniversary of AMA, I would like to send message of congratulation to Mr Yohizuke Kishida, President of Shin Norinsha Co, Ltd, may and Chief Editor of AMA will become more popular in the future especially in Asia, Africa and Latin America. On his occasion, a report on the progress of farm machinery applications in Indonesia especially related to the SDGs is presented.

The merits of the use of mechanization for development of agriculture, especially in rice production area:

1. Using tractors can:
  - a. Improve the efficiency of human labor
  - b. Reducing hard labor for the

- farmer
  - c. Wider area of cultivated land per unit time
2. Faster planting works using rice transplanters
3. Wider area for harvesting work per unit time and faster harvest time using harvester
4. Reducing post-harvest losses
5. Lowering the cost of production
6. The quality and quantity of agricultural produce guaranteed
7. Creating more job opportunities for farmers for post-harvest handling activities
8. Increase rice production
9. Improving the economic growth of farmers

These merits have given impact on achieving SDGs (UNDP, 2020) namely as indicated by the increase in farmers' exchange value index

(Fig.2). This leads to responsible consumption and production, decent work and economic growth, zero poverty, zero hunger and good health and wellbeing.

## Availability of Farm Machinery

At present the availability of farm machinery in Indonesia has been increased from 2010 to 2016. Starting 2011, rice transplanter was beginning to be introduced. Since then the number has been increased significantly. Since 2012 power thresher and combined harvester were introduced. Their number including rice transplanter have been increased recently, especially after the government has established an

Fig. 1 Rice production in Indonesia

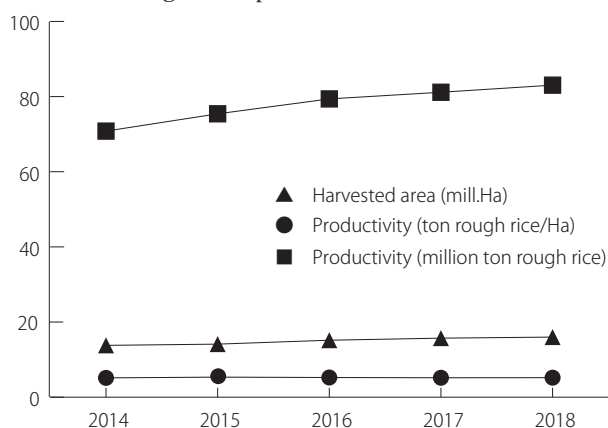
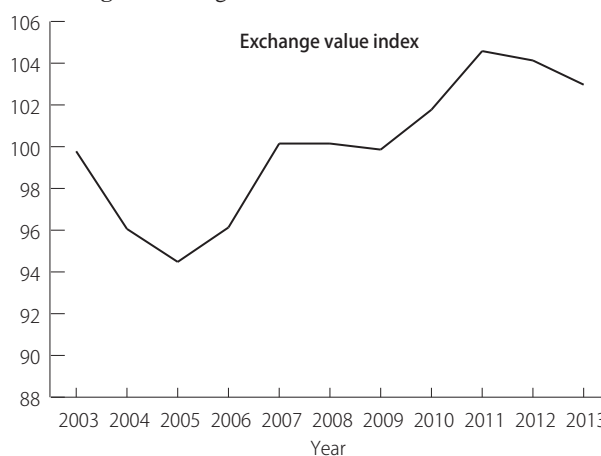

Fig. 2 Exchange value index of farmer's income



UPJA (Farm Machinery Service Unit) in 2008 to farmers group in all of the province in Indonesia. This unit provides services to do farm work such as:

- Land cultivation using tractors
- Irrigation using water pump
- Harvesting using combined harvester
- Threshing using power thresher
- Drying of rough rice, corn, soy bean using dryer Source: Ministry of Agriculture

Each unit covers an area of 30 Ha. Since the establishment of the unit is just in the beginning they

are still need improvement in manpower for technical works as well as for managerial works. Central Java province where the unit can be found most with 2,096 units, followed by South Sumatera province with 772 units and South Kalimantan province with 735 units.

vested area and productivity are also increase accordingly as can be seen from **Table 2** and **Fig. 1**.

- Rice milling using RMU
- Other service works using farm machineries
- Workshop

As shown in **Table 1**, except in 2011 the number of farm machinery provided by the government has been increased from 2010 to 2016.

### Exchange Value Index of Farmer's Income

The exchange value index is the ratio between the prices of produces sold by the farmer against the price of their consumption. If the value of index is greater than 100 meaning the farmer has increase in their income. (Sri Hastuti Suhartini and I. Wayan Rusastra, 2015)

Ministry of Agriculture, (2016)  
 BPS (Bureau of Statistics), (2016)  
 Sri Hastuti Suhartini and I. Wayan Rusastra, (2015), AARD (Indonesia Agency for Agricultural Research and Development), Ministry of Agriculture.

■ ■

## Rice Production

As the impact there has been increase in rice production where mechanization is mainly take place from 70.8 million of rough rice to 80 million tons in 2018. The har-

## REFERENCES

UNDP, Sustainable Development Goals (2020). Visited July 2020 <https://www.undp.org/content/undp/en/home/sustainable-development-goals.html>

**Table 1** Realization of government supply of farm machinery

Year	Two wheel tractor	Four wheel tractor	Water pump	Rice transplanter
2010	4,036	7	3,622	0
2011	662	11	410	176
2012	1,567	50	600	0
2013	3,996	0	2,002	153
2014	15,435	0	4,069	379
2015	25,509	1,244	16,271	5,074
2016	262,090	2,822	354,699	8,601

Source: Ministry of Agriculture, 2016

**Table 2** Increase in harvested area and production of rice in Indonesia

Year	Harvested area (mill.Ha)	Productivity (ton rough rice/Ha)	Production (million ton rough rice)
2014	13.790	5.135	70.812
2015	14.120	5.341	75.415
2016	15.160	5.236	79.378
2017	15.712	5.165	81.153
2018	15.995	5.192	83.044

Source: BPS (Bureau of Statistics)

# Sustainable Development for Agricultural Products Processing Industry and Agricultural Mechanization in Vietnam



by

Nguyen Hay

Ph.D, Professor of Faculty of Engineering-Technology,

Nong Lam University

HoChiMinh City, VIET NAM

Vice President, Vietnamese Society for Agricultural Engineering

ng.hay@hcmuaf.edu.vn

Vietnam economy is now one of the world's fastest growing economies and the agricultural production always plays an important role in the economy throughout the time. However, together with the achievements, the economy and agricultural production also suffer problems from not growing sustainable, such as damaged environment, climate change, sea level rise, soil salinity. Therefore, Vietnam's government calls for scholars from many different areas to do research about sustainable development for the economy and the agricultural production as well.

Agricultural products processing industry in Vietnam has developed rather good, with the capacity of processing 120 million tons of agricultural products per year. This industry with 7,500 firms and many household productions can fulfill domestic demand and also export to the world. Agricultural mechanization has been applied intensively in many parts of production, including soil preparation (94%), planting (42%), caring (77%), harvesting (65%). These achievements lead to a trend of applying more automation and robotics in agricultural production and a move towards a smart

agriculture in Vietnam.

Besides the progress, both agricultural products processing industry and agricultural mechanization still remain with some problems. Regarding the former, many firms have not fully controlled the raw materials for production, the capacity of processing some agricultural products are still weak and cannot fulfill the domestic demand, the loss of post-harvest is still large, the industry still has not developed well compared to the world, processed products are mainly semi-processed and the government's policies still have not fully supported for the industry. About the latter, the percentage of mechanization in some parts in production are still low, the machines are still backward with low capacity, the financial mechanism is limited to the industry, the infrastructure of raw materials areas are not well-prepared for mechanization and high volume agricultural production. Together with the mentioned problems, climate change also affects the agricultural products processing industry and agricultural mechanization through damaging the raw materials areas. In addition, machinery manufacturing technology and the quality of human re-

source in the industry is still limited as these issues hinder the development of processing industry and mechanization.

Based on the facts, there is a need to find the way out for the sustainable development of agricultural production. Some ideas and solution can be considered including, promoting mechanization and processing industry with modern technologies, automation and robotics; developing suitable machinery manufacturing technology for the manufacturing condition, infrastructure and raw material in Vietnam; cooperating with advanced countries, such as Japan, the United States, South Korea, Taiwan, in processing industry and mechanization for learning experience and supporting each other; applying digital technology for achieving a smart agriculture industry with high quality products and protecting the environment at the same time; improving the quality of human resource working in the industry.

Specifically, Vietnam strives for better economic growth for the period after 2020:

- The proportion of agricultural products processing industry in the Gross Domestic Product

- (GDP) rises to over 30%
- The growth rate of processed agricultural products will reach 7-8% / year
- Over 50% of establishments processing key agricultural products for export will reach the level of Advanced Manufacturing Technology
- Labour productivity will rise to over 7%/year
- Average power requirement of machinery reaches 3.5 HP/ha; 5-6 HP/ha after 2020
- Using four-wheel tractor instead of two-wheel tractor
- Mechanization of large-scale agricultural fields

To achieve the above mentioned goals, the Vietnamese Government will focus on:

- Developing programs to support enterprises in agricultural products preservation and processing
- Financial incentives and tax policy for mechanization, agricultural processing; strategies to reduce post-harvest losses
- Land policy for agricultural production
- Strategies for sustainable agricultural development
- National high-tech research and development program for agricultural products preservation and processing
- Moving towards agriculture 4.0
- Running projects on agricultural mechanization and reducing post-harvest losses

Over the past few years, thanks to the establishment of the AMA Journal (Agricultural Mechanization in Asia, Africa and Latin America), and as a senior lecturer, the former Dean of the Faculty of Engineering and Technology and the Vice President of Vietnamese Society of Agricultural Engineering, I have acquired the great knowledge, helping me convey good ideas to the students and researchers.

This year, AMA is 50 years old, an important milestone marking the growth of the journal. I would like

to represent the researchers in the field of Agricultural Engineering in Vietnam to wish AMA Journal all the best.

In the future, with AMA as a strong link, I look forward to the closer and more effective collaboration between researchers in the field of Agricultural Engineering, the support and assistance of all AMA's colleagues. I do hope that we can implement appropriate measures to improve agricultural productivity in Vietnam and all over the World.

In addition to being a Co-Editor of AMA, I look forward to the collaboration in seminar organization, technology transfer in agricultural mechanization and bilateral or multilateral research collaboration.

## REFERENCES,

1. Pham Van Lang, Nguyen Hay, Do Thi Tam, Nguyen Tien Han, "The Role of Agricultural Mechanization in the Process of Modernization of Agriculture in Viet Nam - Contribution of Agricultural Engineering to production after years of conducting renovation ", International specialized medium for Agricultural Mechanization in developing countries, AMA, Agricultural Mechanization in Asia, Africa and Latin America; Pages: 79-88; Volume 50, No.3 ,2019 - ISSN 0084- 5841
2. X. Quang. Nguyen, A. Duc Le, N. Phuong Nguyen, Hay Nguyen, "Thermal Diffusivity, Moisture Diffusivity, and Color Change of Codonopsis Javanica with the support of the Ultrasound for Drying," Journal of Food Quality, Vol. 2019, Article ID 2623404, 13 pages, 2019.

■ ■



# Egyptian Agriculture and Current Situation of Agricultural: Tractors and Equipment in Egypt 2009-2018



by  
Taher Kadah  
Senior Researcher  
Central Lab of Residue Analysis of Pesticides and Heavy Metals in Food (QCAP),  
ARC, EGYPT  
Taherkadah166@hotmail.com



Rania Khamis Ibrahim  
Senior Researcher  
Agricultural Engineering research Institute,  
ARC, Egypt  
Rania.ibrahim22@yahoo.com



Hanafi Radwan  
Emeritus Chief Researcher  
Agricultural Engineering research Institute,  
ARC, EGYPT  
ashourhanafi@yahoo.com



Ahmed El Behery  
Emeritus, Chief Researchers  
Agricultural Engineering research Institute,  
ARC, EGYPT  
behery28@yahoo.com

## Introduction

The Egyptian Economy is undergoing a process of liberalization and privatization. Agriculture is at the heart of the economy and consequently the liberalization and privatization policies have a significant influence. Farmers now are free to cultivate any crop they wish.

Egyptian economy has traditionally relied heavily on the agricultural sector for food, fiber and other products. The agricultural sector provides the livelihood for about 55% of the inhabitants and employment for about 34% of the total employment labor force. In addition, agriculture contributes about 20% of the gross domestic product (GDP) and about 20% of the total exports and foreign exchange earnings.

The demand for agricultural products is increasing due to population increase and the need for more export earnings. The country plan is to cultivation a total of 3.4 mil-

lion acres from the desert area up to the year 2030. This requires more emphasis on agricultural research to identify agricultural sector constraints and to develop solutions through appropriate technologies especially in the newly cultivated and reclaimed areas. International Donor Agencies are helping the government to implement its policies, by providing technical assistance and funds. Most of these funds directed toward farmers and the private sector. This article is concerned with mechanization. There is research and practical evidence that specific farm mechanization will enhance agricultural yields, lower production costs, and produce a positive net income for the farmers and national economy. The most factors are:

- Agronomy practices: improve yield through new technology tillage and cultivation practices.
- Crop Calendar Optimization: Crop yield improved through timely planting and harvesting.

- Reduced Production Cost: Output per worker-hour increased, therefore, reducing on farm production labor cost.
- Harvest Loss Recovery: On-farm crop losses of main crops through improvement of harvesting technique.
- Enhance current levels of mechanization.

## Mechanical Operations

### Land Preparation

This phase involves the various field operations for preparing the land for cultivation, including seedbed preparation and planting vegetable and perennial crops. The primary purpose of tillage operation is to produce edaphically conditions that are best suited for germination, seeding development and crop establishment. Soil structure within the seedbed should:

- Provide the necessary soil-seed

contact to ensure good germination.

- Allow plant roots to penetrate easily into the soil to a proper depth so roots can exploit the available nutrients and water.

Seedbed preparation influenced by numerous factors, the most important of which are tractors power, tillage equipment and seedbed preparation system used.

In Egypt, Soil is prepared for planting two or three time a year that is for winter, summer and Nile crops. Due to the intensive nature of agriculture, the time for soil preparation is very limited. After crop harvesting, the soil is prepared directly without any adjustment for soil moisture. For example, to prepare the soil for wheat cultivation, plowing occurs in the wet soils after the rice harvest, in small areas and in very dry soils after cotton picking. Under such circumstances seedbed preparation, is technically very difficult operation since the clay soils are too sticky to plough when soil is wet and under dry conditions, large clods produced.

In both cases, expensive secondary tillage operations needed to produce a proper seedbed, with these physical and environmental conditions, the tillage implements available. to farmers are not efficient for adequate soil preparation.

Normally farmers use the chisel plough for field plowing in two directions, one perpendicular to the other. The maximum attainable depth of the two paths ranges from 15 to 18 cm according to the prevailing soil conditions.

Recent studies have emphasized the difficulty of good seedbed using these implements. The poor seedbed made the use of mechanical planters or seeders impracticable. In such a

**Table 1** Number of tractor

Year	2009	2018
Inside the valley	103,777	125,883
Outside the valley	6,291	10,261
Total	110,068	136,144

case, there is a high chance of machine damage and a negative effect on seed germination. Manual planting is the common practice now. The result of both poor seedbed and manual planting is affecting germination rate, poor crop stand, and uneven plant growth, and thus a lower yield.

### Planting

Nearly all planting and seeding are done by hand. Tractor rental station with the ARC, has successfully introduced the use of seed drills for wheat planting. Because of this program farmers, are now aware of the merits of using mechanized planting techniques. For potatoes, some farmers are now using semi and fully automatic planters, but on a very limited scale in old land, but is widely used in new land. For rice, small areas are planted using the Japanese rice transplanting system. Apart for this, there is no mechanized planting for other crops except on state farms or research projects. The main problem facing the use of mechanical planters and seeders is the current practice seedbed preparation.

## Agricultural Tractors

The data for the average period (2005-2009) five years mechanization plan estimated the number of agricultural tractors reached about 133 thousand tractors. This is an

average of 7 tractors for each 1,000 feddan (420 ha) (1 Fedan = 0.42 ha). The published figures from the undersecretary of agricultural economics, Ministry of Agriculture, Source: Central Department of Economic Affairs Sector, MLAR, Egypt in 2018 indicates that the tractors numbers was 136,144 as shown in **Table 1**.

### Tractor Annual Replacement

In general, farmers keep their tractors as long as possible; the average lifetime could be 15 years. Consequently, This means an annual replacement of 3,000 tractors. Mainly 95% of imported tractors from Romania, Russia and the Czech Republic, but the remaining 5% of the replaced tractors imported from Western countries. The following is the estimated numbers of each power range to fulfill the required operations yearly:

Current trends of increasing the prices of Eastern type tractors will encourage farmers to buy Western type tractors.

### Tractor Manufactures Origin

There are at least 11 different tractors brand in the tractor population: 38% are Romanian (U.T.B), 32% Russian (Belarus), 10% Egyptian local assembly (Nasr), 3% Czech Rep. (Zetor). 9% Western types (Fiat, MF, Kubota, act), 1% (former) Yugoslavian (I.M.T and I.M.R) and 7% other makes as shown in **Table 2** and **Fig. 1**.

**Table 2** Tractors origin

Country	Brand	%
Romanian	Universal	38%
Russia	Belarus	32%
Egypt	Nasr	10%
Czech.Rep	ZETOR	3%
Western Type	DEUTZ, Lamborghini, new Holland, John Deere, Kubota, Case IH, SAME	9%
Yugoslavian	IMR, IMT	1%
Other makes	Foton	7%
Total		100%

Source: Central department of economic affairs sector, MLAR, Egypt

**Table 3** Yearly tractor replacement

Tractor No.	Power range
500	25-45 HP
2000	65-70 HP
500	90-150 HP

Source: Professional estimates

### Power Range

The tractor power range Majority tractor power population is 65-70 hp represent 76.6%, while 23.4% are 25-60 hp. A noticeable difference exists among the governorates for this parameter as shown in **Table 3**.

### Tractors Ownership

According to survey studies, 95.7% of tractor population is owned by private farmers and hire service contractors. Cooperatives own 1.4% while the remaining quantity owned by government agencies.

### Tractor Population Density in Governorate

On average, there are 11 tractors for each 1,000 feddan (420 ha). The difference among governorates is obvious. In Qena, the rate is 13.6 tractors per 1,000 feddan, as compared to 10.6 tractor per 1000 feddan in Dakahlia. In Fayoum, there are 8.8 tractors per 1,000 feddan.

The variation among the three governorates also exists among districts within the same governorate and among villages in the same districts.

### Available Tillage Agriculture Implements

Tillage equipment classified into two main categories:

Primary tillage equipment cut and shatter soil and may bury trash by inversion, mix it into the tilled layer or leave it undisturbed. And secondary tillage equipment operate on shallow soil depth, providing additional soil pulverization, leveling and firming the soil, reducing air pockets, killing weeds and helps to conserve moisture.

In Egypt, the distinction between primary and secondary tillage is not known and the tillage implements available to the Egyptian farmers on a very limited scope. The most common chisel plough is a locally produced tractor mounted type, with seven shanks. The plow width is 2 m. Maximum attained depth in one path is not more than 15 cm. From a professional point of view, this plough not considered as primary tillage equipment, but rather as a cultivator. Recently in sugar cane areas, farmers have started to use two bottom Mould-board plow but on a very limited scale. Secondary tillage tools like disc harrows and rotary tiller are limited use to the majority of the farmers.

The hydraulic field leveler is well designed and is reasonably efficient. It is manufactured in medium size workshops and companies. It has 1.8, 2.4, 3 or 3.6 meter operating widths. The last two sizes accommodate laser-leveling requirements.

In summary, the only tillage implements owned by farmers and private sector machinery service operators are:

- Chisel plough (cultivator).
- Rotary tiller
- Furrow opener
- Field leveler
- Disc Harrow

### Role of Dealers, Distributors and Local Manufacturers

One of the main functions of dealers and distributors should be to market their goods by demonstration at field days, providing a comprehensive after-sales service, making spare parts available and providing training for end-users. These functions are new for most dealers and distribution as other organizations used to perform these functions on their behalf. With the implementation of privatization, dealers and distributors will have to undertake these functions in order to establish

themselves in the market. The concerned institutions can help in this transitional phase by cooperating with dealers in demonstrations and in disseminating information. One of the key functions of the Egyptian Agriculture Bank is to encourage private distributors at the branch level by providing loans for the provision of technical assistance to end users. The development of local manufactures of farm machinery is a crucial factor if the level of mechanization is to be improved. Local manufacturers can ensure reasonable prices, the availability of spare parts, and the continuous development of the machinery. Although farm machinery is not very complicated, it requires materials of certain specifications and tolerance. Farm machinery manufacturers are well established in Europe but, locally immature. upgrade the industry for local manufacturers to establish institution provide loans to local manufacturers to upgrade their facilities and construct new production lines. The following are tentative list of manufacturers, companies and dealers functions in Egypt **Table 4**.

### Ministry of Agriculture's Role and Support

In the late 1970s, the government of Egypt and MALR took the lead on promoting machinery custom hire service stations in each governorate, the main goal of these stations was to provide machinery services to farmers on actual cost, and introduce new type of equipment. The Ministry of Agriculture and Land Reclamation considered these stations as a pilot activity. The aim behind that was to encourage small contractors on village level to establish similar centers. The Ministry of Agriculture has established about 146 stations and some stations are under construction. Also, the public sector was involved and established ASWAN mechanization

Co., NUBARIA engineering Co., and MENIA mechanization Co. In the meantime, QENA mechanization Coop. and General Mechanization Coop. were established and functioned at the same period. The Agricultural Engineering Research Institute being the official national governmental body is responsible for leading and conducting applied research on agricultural engineering. The main emphasis of the involvement is to strengthen and build up the agricultural machinery adoption process, this means to develop, test, and extend suitable technologies which address the most critical bottlenecks and constraints in the farming system.

## Training Activities

Concerning Ministry of Agriculture and Land Reclamation strategic plan on capacity building in mechanization field, the ministry has established specialized agriculture machinery training centers fully

equipped with advanced teaching materials and equipment. The following is a tentative list:

- Farm Machinery Training Center, Mamoura, in Alex. Governorate.
- Farm Machinery Training Center, Bilbas, in Sharkia Governorate.
- Rice Mechanization Center, Meet Eldiba, in Kafer El Shaik Governorate.
- Sids Machinery Training Center, Sisd, In Bani Souif Governorate.
- Senblaween Training Center, in Dakahlia Governorate.

## Agriculture Tractors and Equipment

### Number of Agriculture Tractors and Equipment at the Level of the Country Tractors

Statistical data for the period (2009-2018) indicate that the number of tractors increased from about 110 thousand in 2009 to about 136 thou-

sand in 2018, an increase of about 23 thousand, which represents about 20.7% compared to the same in 2009, for many reasons perhaps the most important increase in agricultural newly reclaimed land during the period as shown in **Table 5** and **Fig. 1**.

### Irrigation Pumps

As shown **Fig. 2** Statistical data for the period (2009-2018) indicate that the number of irrigation pumps increased from about 806 thousand in 2009 to about 1,013 thousand in 2018, an increase of about 211.8 thousand representing about 26% compared to the same in 2009. This may be due to the development of irrigation methods and desert reclamation during this period.

### Threshing Machine

As shown **Fig. 3** Statistical data for the period (2009-2018) indicate that the number of threshing machine increased from about 55.99 thousand in 2009 to about 73 thousand in 2018 with an increase of about 14.7 thousand and about 25%

**Table 4** List of Egyptian local companies produce agricultural equipment

No.	Item	Company	Tanta	Mabrouk	Raga	Mitto for	El-	Etmeed	ElNasr	MM	Dia-	Others
		Location	Motors	Inter.	Egypt	trading	Wady	Asuet	Co.	Alex	mond	
1	Cheisl plow		•	•	•	•		•				•
2	Disc harrow		•			•						
3	Field leveler		•	•	•	•						•
4	Bidder & ditcher		•	•		•						•
5	Agri. trailers		•	•	•	•	•	•			•	•
6	Water tank trailers		•	•	•	•	•	•			•	•
7	Chemical sprayers		•		•	•	•				•	•
8	Chopper machine		•	•		•						•
9	Front monnted loader		•	•								•
10	Agri. backhoe		•									
11	Rice mills											•
12	Corn griners		•	•		•						•
13	Cattel feed mixers			•		•						•
14	Environment equipment			•				•				
15	Tractor assambly								•	•		
16	Wheat thresher		•	•							•	•
17	Paddy rice threshers		•	•								•
18	Irrigation pumps assembly				•							•
19	Compost turner		•	•		•						

Source: Ministry of Agriculture and land Reclamation, Egypt

**Table 5** Numbers of agricultural tractors and equipment in the governorates (2009-2018)

Years	Agricultural tractors	Irrigation pump			Threshing machines	Other machines & equipment
		Stationary	Mobil	Total		
2009	110,068	140,161	666,122	806,283	55,926	193,861
2010	112,824	144,346	657,685	802,031	58,363	198,277
2011	115,491	149,642	652,725	802,367	58,695	207,651
2012	123,276	173,322	680,684	854,006	62,171	215,731
2013	125,131	165,607	714,846	880,453	63,790	229,882
2014	127,704	174,254	721,732	895,986	67,294	236,447
2015	133,298	175,016	782,518	957,534	71,743	243,847
2016	135,090	198,808	804,889	1,003,697	71,113	251,166
2017	136,683	244,537	769,844	1,014,381	73,224	292,508
2018	136,144	231,375	782,488	1,013,863	73,139	288,995

Source: Central department of economic affairs sector, MLAR, Egypt

compared to 2009.

**Other Machinery and Equipment**

Statistical data for the period (2009-2018) indicate that the number of machines and other equipment increased from about 193.8 thousand in 2009 to about 288.9 thousand in 2018 with an increase of about 90.7 thousand and about 45.8% compared to 2009 as shown in **Table 5** and **Fig. 4**.

**Agricultural Tractors and Equipment at the Level of Egyptian Region Tractors**

As shown **Fig. 5**. The data for the

average period (2014-2018) indicate that the number of agricultural tractors reached about 133 thousand tractors, and the governorates of lower Egypt had the largest share of about 82 thousand tractors, which amounted to about 65% of the total number of tractors, while in the governorates of Middle Egypt on about 19 thousand tractors by an estimated 16%, while the governorates of Upper Egypt accounted for about 19% of the total number of tractors.

**Irrigation Pumps**

The data for the average period (2014-2018) indicate that the number of irrigation pumps reached

about 977 thousand machines, and the governorates of lower Egypt the largest share of about 647 thousand irrigation machines by about 68% of the total number of irrigation pumps, while in the governorates of Middle Egypt About 199 thousand machines at a rate estimated at 21%, and the governorates of Upper Egypt accounted for about 11% of the total number of irrigation pumps as shown **Fig. 6**.

**Threshing Machine**

As shown **Fig. 7**. The data for the average period (2014-2018) indicate that the number of threshing machines reached about 71 thousand machines, and the governorates of lower Egypt accounted for the largest share of about 44 thousand machines, which amounted to about 64% of the total number of Threshing machines. Similarly, in the governorates of Middle Egypt about 14 thousand machines by an estimated 16%, while the governorates of Upper Egypt accounted for about 20% of the total number of study machines and ablation.

**Agricultural Tractors and Equipment at each Governorate Tractors**

As shown in **Table 6** Data for 2018 indicate that the total number of tractors reached about 136 thousand tractors, of which about 125 thousand tractors representing 92% in the governorates within the valley, where the governorates of Kafr El-Sheikh about 16.8 thousand tractors representing 12%, and Sharkia about 14 thousand tractors representing about 10% of the total The number of agricultural tractors in Egypt, respectively, the governorates of Dakahlia 12.5 thousand tractor representing 9%, El-Beheira 12.4 thousand tractor representing 9%, El-Gharbia 11 thousand tractor representing 8%, Assiut 8.1 thousand tractor representing 6%, Menia 8 thousand tractor representing 6%, and Menoufia 7.8 thousand tractor

**Fig. 1** Number of tractors 2009-18 (Unit: thousands)

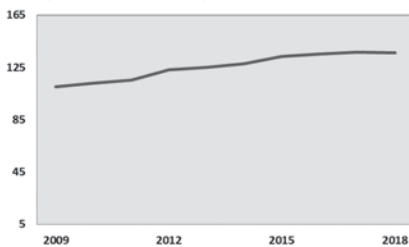

**Fig. 2** Number of irrigation pumps 2009-18 (Unit: thousands)

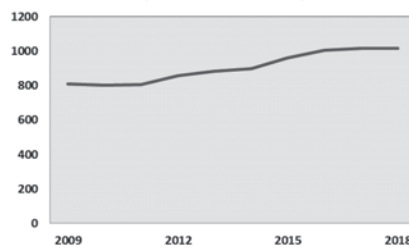

**Fig. 3** Number of threshing machine 2009-18 (Unit: thousands)

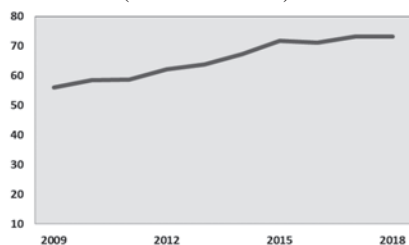

**Fig. 4** Number of other machinery and equipment 2009-18 (Unit: thousands)

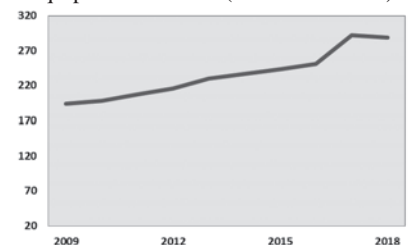

representing 6% for the same year as shown **Fig. 8**.

The governorates outside the valley contributed to the number of tractors about 10.2 thousand tractors representing about 7.6%, mean while Nubaria region about 7 thousand tractors representing about 5% of the total Republic.

**Tractor Population Density:**

The average five years from 2014 to 2018 estimated the number of tractors 133,784 on average of 8 tractors for each 1,000 feddan (420 ha).

The difference between governorates is obvious. In Qena the rate is 15 tractors/1000 feddan, as compared to in Gharbia and Kafr El- Shikh tractors 16 per 1000 feddan in 2018.

**Irrigation Pumps**

The data in 2018 indicate that the total number of irrigation pumps reached about 1,013 thousand machines, of which about 980 thousand pumps representing about 96.7% in the governorates within the valley. The governorates of Sharkiya about 158 thousand pumps representing 16%, Behera about 149 thousand pumps representing 15%, and Al-Gharbia about 109 thousand pumps representing 11% of the total number of irrigation pumps in

**Table 6** Numbers of Agricultural Tractors and equipment In The Governorates, 2018

Governorates	Agricultural tractor	%	Irrigation pumps	%	Threshing machines	%
Behera	12,469	9.16	149,054	14.70	6,465	9
Gharbia	11,305	8.30	109,304	10.78	5,256	7
Kafr – Elsheikh	16,848	12.38	104,030	10.26	14,953	20
Dakahlia	12,570	9.23	35,333	3.48	5,213	7
Sharkia	14,136	10.38	158,958	15.68	7,576	10
Menoufia	7,880	5.79	53,345	5.26	2,707	4
Menia	8,033	5.90	82,235	8.11	6,200	8
Assuit	8,145	5.98	28,772	2.84	7,311	10
Other governorates	34,497	25.34	259,664	25.61	15,978	22
Inside the valley	125,883	92.46	980,695	96.73	71,659	98
Noubaria	7,015	5.15	20,834	2.05	738	1
Other governorates	3,246	2.45	12,334	1.00	742	1.04
Outside the valley	10,261	7.60	33,168	3.06	1,480	2.05
Total	136,144	100	1,013,863	100	73,139	100

Source: Central department of economic affairs sector, MLAR, Egypt

Egypt. The governorates of Kafr El-Sheikh about 104 thousand pumps representing 10%, Menia about 82 thousand pumps representing 8%, Menoufia about 53 thousand pumps representing 5%, El-Dakahlia about 35 thousand pumps representing 3% and Assiut about 28 thousand pumps representing 3% Respectively as shown **Fig. 9**.

The outside the valley contributed to the number of irrigation pumps with about 33 thousand machines representing about 3%, meanwhile the Nubaria region about 20 thou-

sand machines representing about 2% of the total Republic.

**Threshing Machine**

Data for the year 2018 indicate that the total number of Threshing machines reached about 73 thousand machines, of which about 71 thousand machines represent about 98% in the governorates within the valley, where the governorates of Kafr El-Sheikh about 14.9 thousand machines representing 20%, Sharkia about 7.5 thousand machines representing 10% The

**Fig. 5** Tractors at the level of Egyptian region

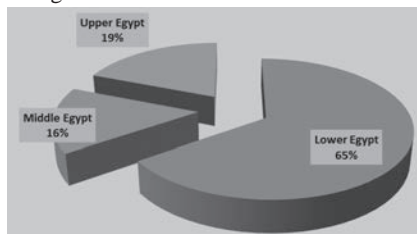

**Fig. 6** Irrigation pumps at the level of Egyptian region

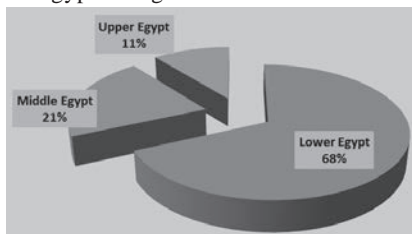

**Fig. 7** Threshing machine at the level of Egyptian region

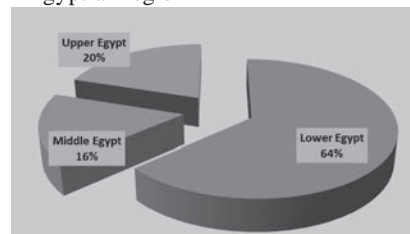

**Fig. 8** Tractors at each governorate

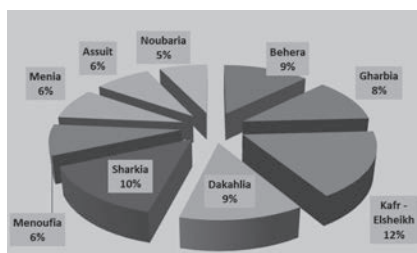

**Fig. 9** Irrigation pumps at each governorate

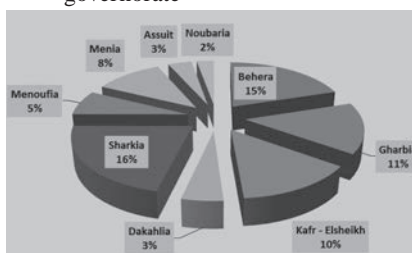

**Fig. 10** Threshing machine at each governorate

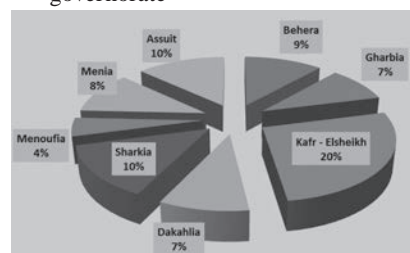

total number of Threshing machines in the Republic, respectively, followed by Assiut about 7.3 thousand machines representing 10%, Behera about 6.4 thousand machines representing 9%, Menia about 6 thousand machines representing 8%, Gharbia about 5 thousand machines representing 7%, Dakahlia about 5 thousand machines representing 7% and Menoufia about 2 thousand machines representing 4% Respectively as shown **Fig. 10**.

The Governorate outside the valley contributed to the number of Threshing machines of about machine a thousand representing about 2% of the total Republic.

**Agricultural Tractors and Equipment by Brand**  
**Tractors**

The average period (2009-2018) indicates that the most used tractors

**Fig. 11** Tractors by bland (Unit: thousands)

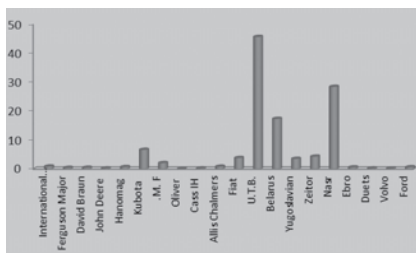

**Fig. 14** Tractors by bland in lower Egypt (Unit: thousands)

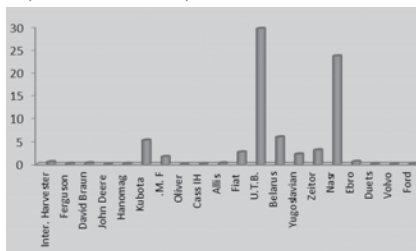

**Fig. 17** Irrigation pumps by bland in lower Egypt (Unit: thousands)

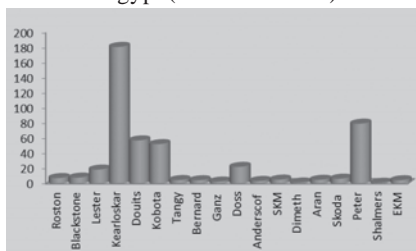

in Egypt are U.T.B, Nasr, Belarus Brand with about 51, 43, 14 thousand tractors representing about 38%, 32% and 10% of the total agricultural tractors. then comes Zetor, Fiat, and Yugoslavia Brand by 3%, 9%, 1% of the total as shown **Fig. 11**.

**Irrigation Pumps**

As shown **Fig. 12** Data for the average period (2009-2018) indicate that the most used irrigation pumps in Egypt Kirloskar, Peter Brand with about 260, 106 thousand machines representing about 29%, 12% of the total irrigation pumps. Then comes Deutz, Kubota Brand representing 9%, 8.7% of the total.

**Threshing Machine**

Data for the period (2009-2018) indicate that the most Threshing machines are local manufactured are 74.6% of the total. But Marshal

**Fig. 12** Irrigation pumps by bland (Unit: thousands)

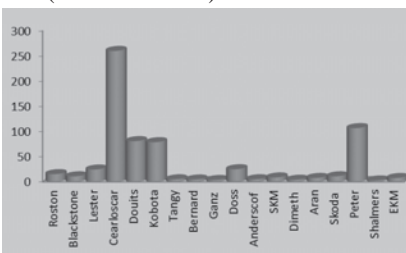

**Fig. 15** Tractors by bland in middle Egypt (Unit: thousands)

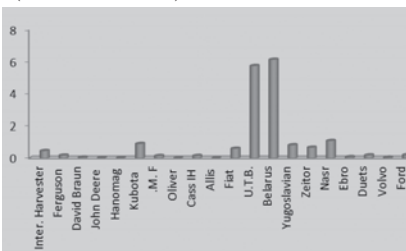

**Fig. 18** Irrigation pumps by bland in middle Egypt (Unit: thousands)

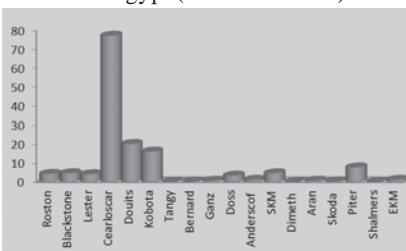

4.6%, and Danube (Bulgarian) Brand representing 4.3% of the total as shown **Fig. 13**.

**Agricultural Tractors and Equipment by Brand Name, According to Geographical Sectors<sup>[1]</sup>**

**Tractors**

The data for the period (2014-2018) indicate that the number of agricultural tractors reached about 133 thousand of tractors, and number in the governorates of lower Egypt about 81.9 thousand tractors, and the most used brands in those provinces Romanian about 29 thousand representing 36%, Nassr Brand about 23 thousand tractors estimated at 29% of the average number of tractors in that period, The Russian brand next 7.3% of the average number of tractors in lower Egypt as shown **Fig. 14**.

While the number of tractors in

**Fig. 13** Threshing machine by bland (Unit: thousands)

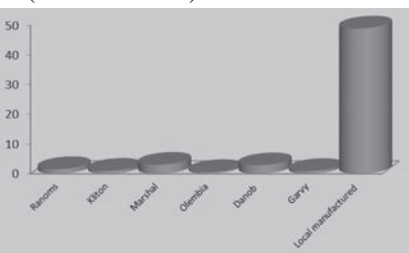

**Fig. 16** Tractors by bland in upper Egypt (Unit: thousands)

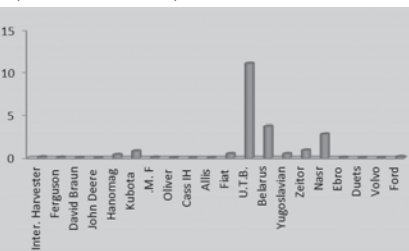

**Fig. 19** Irrigation pumps by bland in upper Egypt (Unit: thousands)

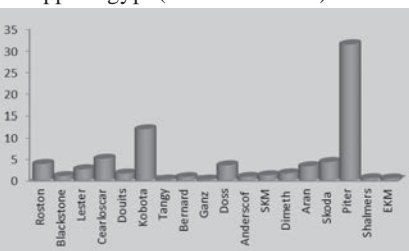

**Table 7** Numbers of agricultural tractors according to powers, ownership in the governorates (2009-2018)

Years	Tractor numbers	Power by HP				Tractor Ownership		
		Less than 35	35-50	51-70	More than 70	Individuals	Associations	Organizations
2009	110,068	7,115	10,238	69,492	23,223	105,519	1,577	2,972
2010	112,824	6,798	10,466	71,907	23,653	107,781	1,899	3,044
2011	115,491	8,512	11,876	70,737	24,366	110,338	1,849	3,304
2012	123,276	8,651	13,264	75,421	25,940	117,468	2,701	3,107
2013	125,131	9,794	12,843	73,828	28,666	117,678	3,597	3,856
2014	127,704	10,358	14,817	74,635	27,894	123,294	1,548	2,862
2015	133,298	12,421	16,600	74,339	29,938	127,469	1,936	3,893
2016	135,090	11,095	18,018	74,765	31,212	130,316	1,988	2,786
2017	136,683	9,385	19,682	72,775	34,841	130,130	3,632	2,921
2018	136,144	9,236	20,080	73,278	33,550	129,642	3,727	2,775

Source: Central department of economic affairs sector, MLAR, Egypt

the governorates of Middle Egypt about 19 thousand tractors, and the most used brands in those provinces, Russia 6 thousand representing 31.5%, and the Romanian about 5 thousand tractors by 29.5% of the average number of tractors in the governorates of Middle Egypt, next come Nasr 5.6% of the average as shown **Fig. 15**.

As shown **Fig. 16** The highest tractor number in governorates in Upper Egypt have acquired about 23,000 tractors, and the most popular brands in these governorates are Romanian and Russia, with about 11.4, 3.7 thousand tractors by 50.4%, 16%, of the average number of tractors in Upper Egypt governorates respectively. Next comes Nasr brand about 12.2% of the average total tractor number of brands.

**Irrigation Pumps**

As shown **Fig. 17**. The data for the period (2014-2018) indicate that the number of irrigation pumps reached about 977 thousand machines, about 647.8 thousand in the provinces of lower Egypt, and the most used brands in those provinces Kirloska about 181 thousand representing 28% , Piter about 79 thousand representing 12%, Deutz about 57 thousand representing 9% of machines in lower Egypt.

As shown **Fig. 18**, While the number of irrigation pumps in the governorates of Middle Egypt about

199 thousand during the average of the same period, and the most used brands in those provinces Kirloska about 77 thousand representing 39%, Deutz about 20 thousand representing 10%, Next comes Kubota about 16 thousand representing 8% of the average number of irrigation pumps in the governorates of Middle Egypt.

As shown **Fig. 19**. The governorates of Upper Egypt acquired about 101 thousand irrigation pumps, and the most used brands in these provinces Piter about 31 thousand representing 32.4%, Kubota about 11.9 thousand representing 12.3% of the average number of irrigation pumps in the governorates of Upper Egypt.

<sup>[1]</sup> **Source:** Central Department of Economic Affaris Sector, MLAR, Egypt.

**Tractors in Terms of Power and Ownership**

As shown in **Table 7** The number of tractors during the period (2009-2018) according to the horsepower less than 35 horsepower, estimated at about 9 thousand tractors representing about 7.4 % of the average number of tractors. While the number of tractors at power 35-50 HP about 14.7 thousand tractors on average, which is about 11.8% of the average total number of tractors. Tractors of 51-70 HP 73,000 tractors as shown **Fig. 20**, representing

**Fig. 20** Tractors according to powers

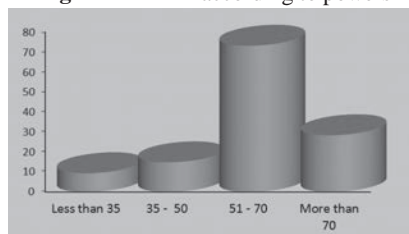

**Fig. 21** Tractors ownership



**Fig. 22** Number of pesticides sprayers

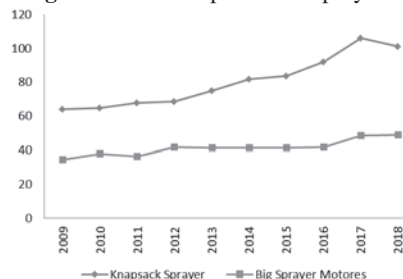

**Fig. 23** Governorates of pesticides sprayers

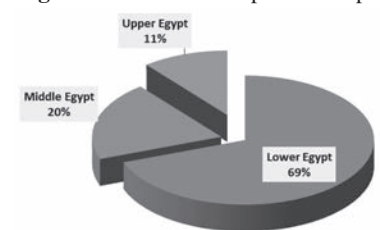



about 58.2% of the total number of tractors. While The number of tractors more than 70 horsepower about 28,000 tractors representing about 22.6% of the average of tractors. The majority of power is between 51-71 HP, where they account more than 58.2% of the total power in the agricultural sector, followed by tractors with more than 70 HP, of 22.6% of the average Total tractors.

Numbers The tractors ownership, the data for the same period show that Tractors owned by individuals and the private sector amounted to 95.5%. next the Organization representing 2.5%, and associations representing 2%. The results show the importance of the private sector in agricultural development, as it has the largest proportion of agricultural machinery. as shown in **Fig. 21**.

### Pesticides Sprayers

As shown **Fig. 22**. Statistical data for the period (2009-2018) indicate that the number of pesticide sprayers in the Egypt increased from about 98,426 in 2009, Including 63,959 knapsack sprayers, 34,467 big sprayer motors to about 149,914 in 2018, of which 101,065 were submachine sprayers, 48,849 large sprayers.

As shown **Fig. 23** Data for the average period (2009-2018) indicate that the number of pesticide sprayers reached about 121 thousand machines, and the governorates of lower Egypt accounted for the largest share of about 78.7 thousand sprayers, which amounted to about 69% of the average total. While in the governorates of Middle Egypt about 22.4 thousand sprayers estimated at about 20%, and the governorates of Upper Egypt accounted for about 11% of the total number of pesticide sprayers.

## Recommendations

In light of the results that can be reached, the study recommends the

following:

1. Increasing the number of Agricultural Tractors in light of the increasing investment opportunities in the agricultural sector in Egypt.
2. Expanding the use of advanced technology in agricultural machinery to increase agricultural production.
3. Study the necessary needs of machines according to the state plan in the agricultural reclamation and agricultural development projects

## REFERENCES:

1. Agricultural research Center, Ministry of Agriculture and land Reclamation, Egypt.
2. Central Department of Economic Affairs Sector, MLAR, Egypt.
3. "Current Situation of Agricultural Tractors and Equipment in Egypt" Published, Vol. 49 No. 2 2018 Agricultural Mechanization in Asia, Africa and Latin America.
4. <https://www.kenresearch.com/agriculture-and-animal-care/agriculture-equipment/egypt-agricultural-machinery-market-report/87315-104.html>

■ ■

# SDGs and Storage Obstacles of Agricultural Production in Egypt



by  
Said Elshahat Abdallah  
Professor  
Dept. of Agricultural Engineering,  
Faculty of Agriculture, Kafrelsheikh University  
Kafr Elsheikh 33516, EGYPT  
saidelshahat@agr.kfs.edu.eg



Wael Mohamed Elmessery  
Associate Professor  
Dept. of Agricultural Engineering,  
Faculty of Agriculture, Kafrelsheikh University  
Kafr Elsheikh 33516, EGYPT

## Sustainable Development Goals and Egypt Vision 2030

The sustainable development goals (SDGs) are of 17 global goals. Sustainable agriculture is a global target for achieving some goals of global Sustainable Development Goal SDGs. The government undertakes many priorities in the agricultural field sectors to achieve the sustainable development goals. It developed a strategy for three priorities through a cooperative program with the FAO from 2018 to 2022, where the Ministry of Agriculture and Land Reclamation signed a technical cooperation protocol to update the sustainable agricultural development strategy in Egypt 2030, which will be funded through the FAO Technical Cooperation Program, as the protocol includes developing an action plan to implement the strategy in the form of medium and short-term plans and programs that include implementation, monitoring and evaluation mechanisms (FAO, 2017). The government's second priority for raising food security degree in strategic food commodities is envisioned through some outputs. The most interesting one is developing a multi-sector action plan to reduce pre- and post-harvest losses and to strengthen the management of post-harvest operations along the value chain, smallholders who pro-

duce grains and horticultural crops (FAO, 2020a).

Egypt is seeking to achieve food security and sustainable agriculture through different plans on short and long terms. Sustainable agriculture is a production practice of integrity of plant and animal over long term. There are many obstacles that face sustainable agriculture in Egypt:

1. Lack of precise data about local and foreign markets to balance the demand and supply mechanics
2. Losses in agricultural production due to the weak storage capacity to accommodate different crops and use of primitive storage technologies.
3. Poor connection between small farmers with academic researches for agricultural practices and knowledge transfer.

The losses in Agricultural production are different from one crop to

another for example the wheat grain losses have started with 50% at 2015 to be from 10 to 20% at 2020, After the expansion in number of silos

## Grain Storage Problem and the Governmental Efforts

Egypt's average production of wheat amounts to 8.45 million tons and expected to be in 2020 about 9.5 million tons and imports more than six million tons. Where in 2020, the total cultivated area of wheat is 3.4 million Feddans (1 Feddan = 0.42 ha), compared to 3.1 million Feddans last year, **Fig. 1**.

Due to poor wheat storage system, 50% of wheat production was wasted (Arabfinance, 2015). The government has determined the defects in the wheat storage system, and in order to implement the largest national

**Fig. 1** Annual wheat production in Egypt from 2010 to 2018, (Statista, 2020)

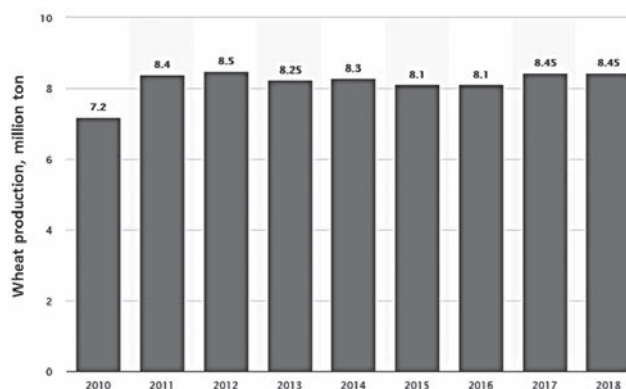

project for wheat storage to maintain its quality and reduce its waste, and eventually reduce the huge cost of food. The project includes 50 silo plants for wheat and grain storage to be implemented and constructed in 17 governorates, **Fig. 2**, with a storage capacity of 1.5 million tons, and they are: Burqash in Giza, Mitt Ghamr and Sherbine in Dakahlia and Qantara in eastern North Sinai, Tanta in Gharbia and Menouf in Menoufia, Heya in Sharkia, Damanhur in Beheira, Sabahiya in Alexandria, Qena and East Al-Aweinat in Al-Wadi Al-Jadid, Banha in Qalyubia, Bani Sweif, Bahnasa, Sheikh Fadl in Minya, Tamiya in Fayoum, and Al Maphalsa in Aswan, (SIS, 2020).

### Silo Storage

There are two main companies for

silos and storage in Egypt, the oldest one is General Cooperation for Silos and Storage (GCSS). The GCSS Company was established by a decree issued by the prime minister on May 25, 1888 (GCSS, 2020). The second company is Egyptian Holding Company for Silos and Storage (EHCSS) which was created at 2002 (EHCSS, 2020), that belongs to the Ministry of Supplies and Internal Trade (MSIT). The national project for wheat storage was launched at January 20, 2015, on an area of 20 thousand square meters for one silo plant.

The total number of silos at the national level reached 74 silo plants, with a storage capacity of 3,880 million tons in August 29, 2020 (EHCSS, 2020).

### Field Silos Plan

Sharkia Governorate has suffered for long periods of poor infrastructure to store and receive wheat supplied by farmers, even though it is ranked second in wheat production. The project to establish field silos close to the collection centers for farmers to save transport costs for them and reduce their burdens so that crops can be better collected to enhance the supply processes, **Fig. 3**.

### Open-field Storage (Shona)

The majority of government storage consists of a traditional flat storage system called the Shona. The poor quality of this storage causes specific losses from exposure to weather and pests. In addition, the wheat is handled manually in jute bags, which adds impurities and losses (bags tear easily and are easy to steal). While there are no official estimates available of the losses at the Shona, they are believed to be in the range of 10-20 percent, **Fig. 4**. The government in parallel with the building of the huge iron silos - executed an integrated project to progress 105 open-field storage systems and convert them into modern sophisticated wheat storage “hangers” in 79 locations in 20 governorates.

### Perishable Products Storage Problem

The losses of perishable products (Fruits and vegetables) are determined to be 45-55% of annually production. Grapes and tomatoes are the most vulnerable to loss in

**Fig. 2** Silos locations over the country of Egypt



**Fig. 3** Field silos for wheat storage in Sharkia



**Fig. 4** Open field storage (Shona) Before (A) and After (B) developing



production. The ancient methods of fruit harvesting, packing, transportation and distribution are still followed in many farms, and studies for determining the stages of fruit picking according to the marketing system near or faraway the markets did not take sufficient attention, especially in many fruit crops, as the means of precooling, refrigerated transport and refrigerated stores are not sufficient to preserve the fruits from harvest until packing with the least amount of spoilage, knowing that the vast majority of horticultural products are perishable because they contain a high percentage of moisture, many of horticulture products contain a high percentage of sugars that promote the growth of pathogens, in addition to that. Insufficient packaging houses and the failure to keep pace with the new in the science and arts of packaging and packing, and the insufficiency of land and sea refrigerated transport and reliance on air freight increases marketing costs and reduces price competition for the product in foreign export markets. The serious loss was at retail and wholesale of the value chain. To reduce this loss percentage the value chain should be developed. The development

**Fig. 6** Tomatoes paste and juice plants in Egypt



should start from postharvest to marketing and eventually to the processing stage, (FAO, 2020b). FAO launched a project starting in 2015 to 2019 focusing on the value chains of tomato and grape, they realizing an awareness campaigns to small-scale farmers about the techniques should they follow at harvesting and if the market prices are low, they will dry the tomatoes and grapes. This solution in application is not economically feasible if there is not a tomato processing plant nearby the field to correctly receive the dried tomatoes or at least drying and packaging station as shown in **Figs. 5** and **6**. Grapes need also this drying station to handle the excess production safely.

**The Program of Cold Chain for Agricultural Products**

The program of cold chain is an important to consider in the advanced supply chain to reduce the respiration rate, microbial activities and ripening process. After harvesting, the cold chain program starts instantly including packing, precooling, transportation, cold storage, and eventually market supplying. Cold chain program interests field heat removal from the perishable products. Quick precooling enhances freshness, progressing cold storage, and prevent chilling hurt (Yahia and Smolak, 2014) Post harvest losses is nearly up to 25-30% without precooling, which reduced to be only 5-10% by precooling (Yang et al., 2007).

**Fig. 5** Training on tomato drying as a sustainable solution to food losses and waste reduction



**Methods for Precooling the Produce**

There are seven principal methods of precooling horticulture crops; room, forced air, hydro, ice, vacuum, cryogenic and evaporative cooling. The perishable products enter the precooling mean either as raw material or after packing. The precooling facility works on heat removal from the produce caused by temperature gradient between the internal air and the agricultural product, which is called heat driving force. With larger heat gradient, quicker heat transfer is occurred. The room cooling method may take several days to cool down from 20 to 5 °C (Elansari et al., 2019). Room cooling has less field heat capacity than other precooling methods; due to the heat transfer depends on convection transfer. Forced air precooling method, **Fig. 7**, can reduce the temperature of grapefruit of 14.6 °C in 2.5 hour. However, the cooling room method reduces only 3.5 °C in 2.5 hour (Barbin et al., 2012). (Wu et al., 2018) studied the influence of package type on cooling rate

**Fig. 7** Forced air precooler

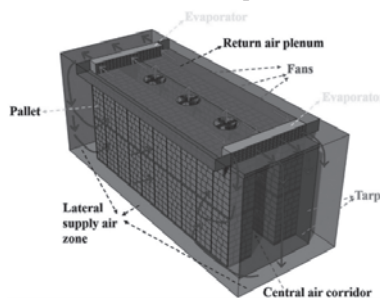

**Fig. 8** Mobile precooling system



and heterogeneity that indicates the open top packs have slowest cooling rate and highest heterogeneity.

It is recommended to use mobile pre-cooler, **Fig. 8**, which can move to the harvesting location to reduce the delaying time between harvest and precooling and reduces the handling processes (Kitinoja and Thompson, 2010).

The mobile precooler can be stand next to the picking crew which allows the crop to rapidly accommodate as they are harvested.

### Poultry and Beef Cold Storage

According to statistical report of Ministry of Agriculture and Land Reclamation (MALR) that only 86.7 million from 589 million broiler chicken have been slaughtered by slaughterhouses, If all broiler farming uses its full growing capacity, the slaughtering deficit will 35%. In addition, the slaughterhouses have an inferior infrastructure of equipment of cold storage, FAO, 2017 and MALR, 2015, **Table 1. Fig. 9** shows most of cold storages concentrated on the districts of Cairo and Giza.

The cold storage plants are not only for poultry and meet storage that will be competing with fruits and vegetable.

### Freezing Equipment

The freezing industry has emerged as one of the primary means of preserving this expected agricultural production. However, freezing as a means of preserving food, despite its spread, leads to the emergence of some defects that negatively affect the quality and safety of frozen food, most notably the mechanical effect on the tissues of the food item. As a result of the natural increase in the volume of the nutrient, by converting its moisture content into ice crystals, the freezing period becomes slower.

The slow freezing process leads to the growth of these crystals in size, which results in severe damage to the tissues of the food item, which appears in the form of separation of the cellular juice for these materials after melting them. It also leads to the activation of some chemical reactions that negatively affect the quality of frozen food. There are many types of traditional freezing equipment can be used to store the agricultural products. Type selection depends on different factors as: produce sensitivity, shape and size, storage space and production rate. Freezing equipment can be categorized into different groups (1) Direct contact freezers such as; plate freezers (Dopazo and Fernandez-Seara,

2012), scraped surface freezer (Bongers, 2006; Drewett and Har-tel, 2007) and contact belt freezer (Awonorin, 1997) (2) Air as cooling medium freezers such as; still air freezers, air blast tunnel, belt freezer, fluidized bed freezer, and impingement freezer, and (3) Liquid as cooling medium freezers such as; immersion freezers and cryogenic freezers.

### Development in Freezing Techniques

Recently, a number of modern technologies have appeared that address the phenomenon of rapid freezing, so that frozen food appears in a more fresh state. Among these techniques are freezing under a magnetic field and freezing under high pressure, which depends on a single scientific basis called “hyper cooling”, where the food is exposed to a temperature very lower than its freezing temperature, without these materials being frozen by external influence and after homogeneous cooling occurs in all parts of the food item are separated. The rapid and homogeneous freezing in all parts of the food item leads to the formation of very small ice crystals that do not cause significant damage to the tissues of the food item. The advanced freezing techniques are (1) High-Pressure Freezing (LeBail et al., 2002) (2) Dehydrofreezing (James et al., 2014) (3) Hydrofluidization Freezing (4) Ultrasound Freezing (Islam et al., 2014) (5)

**Fig. 9** Refrigerators, freezers and cold storage locations in Egypt



**Table 1** Cold storage growth and its capacity

Years	Number of cold storage	Size in cubic meters	Actual storing capacity, tons
2007	1,328	2,607,204	2,052,605
2008	1,386	2,647,718	1,883,063
2009	1,475	2,679,494	1,670,702
2010	1,572	2,587,819	1,837,518
2011	1,607	2,665,611	1,977,471
2012	1,650	2,752,304	2,734,599
2013	1,560	2,380,710	2,328,310
2014	1,667	2,365,710	2,214,436
2015	1,739	2,151,529	2,153,448
2016	1,843	2,474,974	2,170,525

Magnetic Resonance Freezing (Fikiin, 2008).

## REFERENCES

- Arabfinance. 2015. Half wheat capacity wasted in Egypt due to poor storage: Blumberg <https://www.arabfinance.com/en/news/details/egypt-economy/334463> visited on 10/9/2020.
- Awonorin, S. O. 1997. An Appraisal of the Freezing Capabilities of tunnel and Spiral Belt Freezers Using Liquid Nitrogen Sprays. *Journal of Food Engineering*, 34: 179-192.
- Barbin, D. F., Neves Filho, L. C. and Silveira, V. 2012. Portable forced-air tunnel evaluation for cooling products inside cold storage rooms. *International Journal of Refrigeration*, 35 (1): 202-208.
- Bongers, P. M. M. 2006. A Heat Transfer model of a scraped surface heat exchanger for Ice Cream. In Marquardt, W. and Pantelides, C. (Eds.) 16<sup>th</sup> European Symposium on Computer Aided Process Engineering and 9th International Symposium on Process Systems Engineering. Elsevier B.V.
- Dopazo J. A. and Fernandez-Seara, J. 2012. Experimental evaluation of freezing processes in horizontal plate freezers using CO<sub>2</sub> as refrigerant. *International Journal of Refrigeration*, 35: 2093-2101.
- Drewett, E. M. and Hartel, R. W. 2007. Ice crystallization in a scraped surface freezer. *Journal of Food Engineering*, 78: 1060-1066.
- EHCSS. 2020. Egyptian Holding Company for Silos and Storage: about the company. <https://www.ehcss.com/en/about-company/> visited on 10/9/2020.
- Elansari, A. M., Fenton, D. L. and Callahan, C. W. 2019. Precooling. In: YAHIA, E. M. (Ed.), *Post-harvest Technology of Perishable Horticultural Commodities*. Elsevier Inc.
- FAO. 2017. Broiler poultry industry: investment challenges and opportunities, <http://www.medagri.org/docs/group/71/Egypt%20Poultry%20Sector%202017.pdf> Visited on 10/9/2020.
- FAO. 2020a. MALR and FAO sign a protocol to update Sustainable Agricultural Development Strategy 2030. <http://www.fao.org/egypt/news/detail-events/en/c/1181668/>
- FAO. 2020b. Food Loss and Waste Reduction and Value Chain Development for Food Security in Egypt and Tunisia - Egypt Component. <http://www.fao.org/egypt/programmes-and-projects/food-loss-waste-reduction/en/> visited on 10/9/2020
- Fikiin, K. 2008. Emerging and novel freezing processes. In Evans, J. A (Ed.), *Frozen Food Science and Technology*. P. 101-123. Blackwell Publishing.
- GSSC. 2020. Mubasher Egypt. <https://www.mubasher.info/markets/EGX/stocks/GSSC/profile> visited on 10/9/2020.
- Islam, M. N., Zhang, M., Adhikari, B., Xinfeng, C. and Xu, B. G. 2014. The effect of ultrasound-assisted immersion freezing on selected physicochemical properties of mushrooms. *International Journal of Refrigeration*, 42: 121-133.
- James, C., Purnell, G. and James, S. J. 2014. A critical review of dehydrofreezing of fruits and vegetables. *Food Bioprocess Technology*, 7(5): 1219-1234.
- Kitinoja, L., and Thompson, J. F. 2010. Precooling systems for small scale producers. *Stewart Postharvest Review*, 2(2).
- LeBail, A., Chevalier, D., Mussa, D. M. and Ghouil, M. 2002. High pressure freezing and thawing of foods: a review. *International Journal of Refrigeration*, 25(5): 504-513.
- MALR. 2015. The Economic Affairs Sector at Ministry of Agriculture and Land Reclamation, Statistical bulletin on poultry production
- SIS. 2020. State Information Service: Your Gateway to EGYPT. <https://www.sis.gov.eg/?lang=en-us> visited on 10/9/2020
- Statista. 2020. Wheat production in Egypt 2010-2018 <https://www.statista.com/statistics/972549/egypt-wheat-production/>
- Wu, W., Haller, P., Cronje, P. and Defraeye, T. 2018. Full-scale experiments in forced-air precoolers for citrus fruit: Impact of packaging design and fruit size on cooling rate and heterogeneity. *Biosystems Engineering*, 169: 115-125.
- Yahia, E. K. and Smolak, J. 2014. Developing the Cold Chain for Agriculture in the Near East and North Africa (NENA). FAO Regional Office for the Near East and North Africa, <http://neareast.fao.org>.
- Yang, Z., Ma, Z., Zha, C. and Chen, Y. 2007. Study on forced-air precooling of Longan. *American Society of Agricultural and Biological Engineers*, Paper No. 076267. St. Joseph.

■ ■

# SDGs and Agricultural Mechanization Practice in Nigeria



by

Oyelade, Opeyemi Adeniyi

Co-operating Editor of AMA for Nigeria  
Farm Power and Machinery Department,  
National Centre for Agricultural Mechanization (NCAM),  
Ilorin, Kwara State, NIGERIA  
yemibamigbedjdoyelade@gmail.com

On this special occasion of AMA celebrating its 50<sup>th</sup> Anniversary Special Issue, I feel delighted to present this article titled SDGs and Agricultural Mechanization Practice in Nigeria.

## Sustainable Development Goals

Sustainable Development Goals (SDGs) are the blueprint to achieve a better and more sustainable future for all. They address the global challenges we face, including those related to poverty, inequality, climate, environmental degradation, prosperity, and peace and justice. The goals interconnect and in order to leave no one behind, it is important to achieve each goal and target by 2030.

Following the expiration of the implementation timeline of the Millennium Development Goals (MDGs), which came to end in 2015, the international community through the United Nations in collaboration with the Heads of States and Governments of the 193 Member Nations, launched the Sustainable Development Goals (SDGs) as a new development agenda. This agenda, also known as Agenda 2030, is framed into 17 Goals, 169 Targets and 230 Indicators. Nigeria, being one of the countries that ratified and adopted the Agenda for implementation in September 2015,

proceeded immediately to domesticate it. The domestication began with the data mapping of the SDGs with a view to identifying which agencies of government and other stakeholders could provide relevant and sustained data for tracking the implementation of the programme (OSSAP-SDGs and NBS, 2017).

The strategies put in place by the Nigerian Government for the implementation of the SDGs include: Establishment of an SDG Coordinating Office; Establishment of the NVR Core Working Group; Sensitization and Advocacy; Availability of SDGs Data, Information and Performance Accountability; and SDGs integration into Sector Plans and the National Budget.

Also, one of government's effort put in place to seriously tackle poverty in Nigeria was by establishing the Agricultural Credit Guarantee Scheme Fund (ACGSF) in 1978 which was put under the coordination of the Central Bank of Nigeria (CBN). This scheme (ACGSF) from inception in 1978 to December 2014, according to Olaitan et al. (2017) and Oyelade (2018), has guaranteed a total loan of 929,472 valued at N88.905 billion. The intervention of CBN in the nation's agricultural sector has stimulated the creation of jobs both directly and indirectly. The ACGS intervention has led to the creation of a total of more than 929,472 direct jobs and 3.4 million

indirect jobs.

## Agricultural Mechanization Practice in Nigeria

### Agricultural Production and Productivity in Nigeria

According to Kasali (2018), the agricultural sector of Nigeria is classified into four sub-sectors namely, crops, livestock, fisheries and forestry subsectors. The crops, livestock, fisheries and forestry subsectors of the Nigerian agricultural sector contributed 85%, 10%, 4% and 1%, respectively, to agricultural GDP. Given the large size of the crops sub-sector relative to the other three, growth performance in the crops sub-sector drives overall growth performance in agriculture. Among Nigeria's food staples, cereals account for the largest share of cultivated areas while roots and tubers account for the largest share of production due to their much higher yields per unit land area.

In the Nigerian agricultural sector, the major crops grown in the country are cowpea, sesame, cashew nuts, cassava, cocoa beans, groundnuts, gum arabic, kola nut, maize (corn), melon, millet, palm kernels, palm oil, plantains, rice, rubber, sorghum, soybeans and yams. These crops have commercial potentials of boosting the economy if mechanized through the use of modern tech-

niques and equipment (Kasali, 2018). In Nigeria, agriculture is the most important non-oil economic activity. Most farmers operate at subsistence level, with a marketable surplus of up to 25% depending on the size of the household. Over 90% of the agricultural output is produced by small-scale farmers and low-yielding production techniques.

Agricultural mechanization embraces the use of tools, implements and machines for a wide range of farm operations from land preparation to planting, harvesting, on-farm processing, storage, and marketing of products. Nigeria is still at the early stage of agricultural mechanization; even the mechanization of power intensive operations has been slow. A significantly higher proportion of farming area is still cultivated by hand tools in Nigeria and West Africa compared to other developing countries.

According to Takeshima and Lawal (2018), agricultural mechanization growth in Nigeria over the past several decades has been characterized by a significant spread of animal traction, but with stagnation in tractor use. Tractors were promoted in the 1970s and early 1980s as part of promoting large-scale farming. The share of areas cultivated with tractors has since stagnated at less than 10% for several decades.

The common practice of mixed cropping in Nigeria, where each crop is planted in narrow spaces, does not allow economies of scale from large-sized modern tools. Therefore, Nigeria and the rest of Sub-Saharan Africa (SSA) are expected to continue to rely more on hand tools for the foreseeable future for cultivation. The use of hand tools for land cultivation is still predominant in Nigeria because draught animals and tractors require resources that many Nigerian farmers do not have easy access to (Durban, 1980). The minimum land area needed to make the use of draught animals (5 ha) and tractors (50 ha)

economically viable is too large for an average Nigerian farm household with smaller and fragmented landholdings (which account for 80% of total landholdings in Nigeria).

### **Historical Background of Mechanization Evolution in Nigeria**

According to Takeshima and Lawal (2018), the mechanization level in Nigeria has been generally low. There are, nevertheless, a few relatively distinct phases in which mechanization had been at significantly different levels in scale.

Despite the several advantages to increase agricultural mechanization in Nigeria, it is the most controversial and least understood input. This result to the graveyards of agricultural machinery and implements as it was rampant in the 80's and 90's. If agricultural mechanization is to succeed in Nigeria, it is important for all the key players (policy makers, planners, donors, engineers, marketers, agriculturists, technicians and the farmers) to understand the role and level to which Nigeria agriculture can be mechanized with the consequences of mechanization: - technically, environmentally, socio-economically etc. This has to be understood in the context of the entire farming system.

### **Development of Agricultural Tools and Equipment in the Last Decades**

According to Yusuf (2011), local manufacturing of agricultural tools, implements and equipment is small and limited to the production of hand tools, engine operated machines, animal-drawn equipment and post-harvest food loss prevention prototypes. They employ semi-skilled technicians with inadequate facilities for manufacturing. The quality of implements produced, depends upon the skill achieved through experience over years. The manufacturing of tractors which is a measure of the strength of the local agricultural machinery industry, is non-existent in Nigeria. Rather,

there are tractor assembly plants. The main constraints facing this group include: low quality products; seasonality of markets with small markets and poor cash flow; thin spread of capital due to an attempt to produce too many varied products; inefficient equipment for fabrication; and high tariffs when components or local manufacturing are imported.

Assessing the market for implements is extremely difficult because there is a formal as well as informal sector. Tractors and other prime equipment are imported and produced in the formal sector. The bulk of equipment especially agro-processing equipment are produced in a decentralized manner by local manufacturers in an unorganized fashion. There exist a critical mass of local fabricators in Nigeria producing agricultural mechanization technologies for end users (market). There are probably over 1,000 private sector fabricators of agricultural machinery in Nigeria and possibly many times above this number of fabricators (Ajibola and Zalla, 2007). These fabricators include blacksmiths, artisans, micro, small and some medium scale entrepreneurs. They produce a wide range of products such as hand tools, draught animal implements, ridgers, shears, milling machines, threshers, shellers, hullers, expellers, grinding machines, cassava processing machines, oil palm processing machines etc. Most of these local manufacturers are always not willing to risk production for an unknown, risky market without evidence of demand or pre-paid, firm order. Adekoya (1990) classified agricultural machinery manufacturers into four dominant groups namely research and development institutions, established manufacturers, cottage manufacturers and roadside manufacturers.

The level of mechanization used in agriculture in Nigeria is relatively low. A recent survey exercise conducted by the National Centre for Agricultural Mechanization



(NCAM) in 2018 and 2019 which is to assist policy makers in Nigeria on how to tackle the challenges militating against agricultural mechanization practice in Nigerian agriculture came in at a time when Nigeria has determined to end the era of food importation. This is a phenomenon that has been creating huge losses for the nation when considering the trillions of Naira government spends on yearly basis to feed her ever-teeming population. Findings made by Oyelade et al. (2019a, 2019b and 2019c) on the outcome of the survey exercise carried out on the present status of agricultural mechanization level for cassava processing operations in Ekiti, Ogun and Oyo States of Nigeria, respectively showed that manual processing of the unit operation of cassava processing dominates the unit operations in Nigeria's Cassava Processing Industry.

### **Industrial Policy on Machinery Manufacturing**

Nigeria's attempt in the past to manufacture tractors domestically had largely failed. In the 1970s, two tractor assembly plants and NCAM were established with the aim of releasing 5,000 tractors per year (Jabbar, 1995). Specifically, Nigeria Truck Manufacturers (NTM), assemblers of Fiat tractors as well as Fiat trucks, and Steyr Nigeria Ltd., assemblers of Steyr tractors and Steyr trucks, had been both established in the 70s. Similarly, Peugeot Automobile Nigeria Limited (PAN) and Volkswagen of Nigeria Limited (VWON) were established in Kaduna and Lagos to assemble passenger cars from imported CKD parts and components, through joint ventures between the Nigerian government and these companies (Adu-bifa, 1993). However, both NTM and Steyr Nigeria Ltd. had folded up within ten years of their establishment, and PAN and VWON had also closed within a short length of the period of operations. Even while in operation, many of these compa-

nies complemented their sales with imported implements and equipment. Besides, government policy that production incorporate a minimum of 30% of local content was never adhered to, because of often low-quality of locally produced raw materials like steels (Adu-bifa, 1993; Oni, 2011).

Attempts to raise the local manufacturing capacity have also been made. Mechanization units have been set up within the Agricultural Development Projects, State and Federal government. These institutions and NCAM have been assigned a mandate to coordinate the local R&D conducted by 140 institutions, including universities, polytechnics, research institutes, industrial development centres, incubation centres, and colleges of agriculture, and provide training of machine operators / mechanics / blacksmith / artisans (Rural Artisan Training Support Unit, Ilorin) (Ajibola and Zalla, 2007).

Where tractors have been adopted for farming operation, the adoptions have generally helped smallholders to remain in farming, rather than to induce their exit from farming. Tractor adoptions have not directly induced agricultural transformation in Nigeria. Agricultural transformation in the form of a declining agricultural labour force has happened partly through the growth in the oil industry since the 1970s. Tractor adoptions might have rather helped those who have remained in farming, due to remoteness (and relative farmland abundance), to start expanding their scale of farming.

### **NCAM's Role in the Development of Agricultural Tools and Equipment in Nigeria**

#### ***Establishment of NCAM***

The establishment of NCAM was in response to the need for Nigeria to attain self-sufficiency in food and fibre production. Government was convinced of the indispensable role of agricultural mechanization

to the actualization of Nigeria's self-sufficiency in food and fibre. This, coupled with the ever-present constraints of imported agricultural mechanization technologies some of which are not compatible with Nigeria's prevailing climatic conditions, crops and cropping patterns with their attendant poor after sales back up services, irregular supply of spare parts and other socio-economic considerations, informed the establishment of NCAM, to address these mirage of problems. NCAM was established in 1978 by the Act of the Nigeria's National Assembly, No. 35 of 1990 with the mandate to accelerate the positive transformation of the agricultural sector of the Nigerian economy in order to increase the quantity and quality of agricultural products. The mandate is being achieved through adaptive and innovative research and development activities.

#### ***Achievement of NCAM***

NCAM has been able to record a lot of achievements over the years. Some of these achievements include: development of over 70 proven technologies for the different types of crops grown in Nigeria; evaluation of 85 different makes and models of imported agricultural tractors in ascertaining their suitability for use in Nigerian agriculture; development of seven standards and test codes for agricultural equipment which was done in collaboration with Standards Organization of Nigeria (SON); won 1<sup>st</sup> prize on "Machinery and Equipment Exhibition" during May 2007 Agricultural Show held in Tudun-Wada, Nasarawa State, Nigeria; won 3<sup>rd</sup> prize on "Local Exhibitor" during February 2016 Techno Expo Show held in Raw Materials Research and Development Council (RMRDC), Abuja, Federal Capital Territory, Nigeria; won 1<sup>st</sup> prize on "Machine and Equipment" during October 2017 Agricultural Show held in Nasarawa State, Nigeria; won 1<sup>st</sup> prize in Fisheries Technologies during October

2018 National Agricultural Show held in Nasarawa State, Nigeria; won 1<sup>st</sup> prize in Agricultural Mechanization/Equipment during October 2018 National Agricultural Show held in Nasarawa State, Nigeria; and won 1<sup>st</sup> prize – among Federal Institutes during October 2018 National Agricultural Show held in Nasarawa State, Nigeria.

## Conclusions

The Nigerian Government in collaboration with all relevant stakeholders in Nigeria have put in place several programmes that can help Nigeria meet the 169 set targets of the SDGs. With the recent support received by the Nigerian Government by the office of the United Nations Development Programme (UNDP) on the execution of the 2030 UN Agenda, Nigeria is fully determined to meet up with the 169 set targets of the 17 Goals of the SDGs by 2030.

As agriculture plays a great role to the human race, there is no nation in the world that can survive without food, therefore, all matters concerning improving the level of agricultural mechanization practice in its present form in Nigeria should be addressed by the Nigerian Government. NCAM which is the only federal government parastatal in Nigeria with the specific mandate of promoting agricultural mechanization practice in Nigeria should be strengthened the more by the Federal Government of Nigeria in addressing all the challenges facing agricultural mechanization practice in Nigeria.

As the Nigerian Government have shown great commitment to the 17 goals of the SDGs tagged 2030 UN Agenda so also is the Nigerian Government attention called upon to help grow our economy through the quick diversification of the economy to Agriculture. This could be achieved through: (i) formulating

good policies that will improve the use of agricultural mechanization practice in Nigeria; (ii) promoting the development of locally built agricultural tools, machineries and equipment; and (iii) encouraging end-users to use locally built tools, machineries and equipment.

## REFERENCES

- Adubifa, A. 1993. "Technology policy in national development: A comparative study of the automobile industry in Nigeria and Brazil." *Journal of Asian and African Studies*, 28 (1-2): 42-53.
- Adekoya, L. O. 1990. Agricultural and food processing machinery manufacture in Nigeria: Prospects and Potentials. *Proceedings of the Annual Conference of the Nigerian Society of Engineers*, 162-167.
- Ajibola, F. and Zalla, T. 2007. Value Chain study of small scale agricultural mechanization. *Monograph Series No. 9:i*.
- Jabbar, M. 1995. "Energy and the evolution of farming systems: The potential for mixed farming in the moist Savannas." In *Moist Savannas of Africa: Potentials and Constraints for Crop Production: Proceedings of an IITA/FAO Workshop Held from 19-23 September 1994, Cotonou, Republic of Benin*. Ibadan, Nigeria: International Institute of Tropical Agriculture.
- Kasali, M. Y. 2018. Present Status and Future Prospects of Agricultural Machinery Research Activities in Nigeria. *J. of AMA.*, 49 (2): 135-149.
- Olaitan, M. A., Ogunlaja, B. O., Juma, L., Olasupo, M. A., Yusuf, J. and Oyelade, O. A. 2017. Promoting Agricultural Productivity in Nigeria – The Case of the Agricultural Credit Guarantee Scheme Fund (ACGSF): 1981 to 2014. *J. AMA*, 48(1): 59-70.
- Oni, K. C. 2011. Man, Machine and Food Insecurity. The Ninety-Fourth Inaugural Lecture, University of Ilorin, Ilorin, Nigeria.
- OSSAP-SDGs and NBS. 2017. NIGERIA: Sustainable Development Goals (SDGs) Indicators Baseline Report 2016.
- Oyelade, O. A. 2018. Poverty Eradication through Agricultural Practices for Better Economic Growth in Nigeria. *Continental J. Sustainable Development*, 9(1): 29-39.
- Oyelade, O. A., Ademiluyi, Y. S. and Bamidele, B. L. 2019a. Present Status of the Level of Agricultural Mechanization available for Cassava Processing Operations in Ekiti State of Nigeria. *Continental J. Sustainable Development*, 10 (1): 14-21.
- Oyelade, O. A., Ademiluyi, Y. S. and Bamidele, B. L. 2019b. Present Status of the Level of Agricultural Mechanization available for Cassava Processing Operations in Ogun State of Nigeria. *Continental J. Agricultural Science*, 13 (1): 33-40.
- Oyelade, O. A., Bamidele, B. L. and Ademiluyi, Y. S. 2019c. Present Status of the Level of Agricultural Mechanization available for Cassava Processing Operations in Oyo State of Nigeria. *Continental J. Agricultural Science*, 13 (1): 41-48.
- Takeshima, H and A. Lawal. 2018. Overview of the Evolution of Agricultural Mechanization in Nigeria. *IFPRI Discussion Paper 01750*.
- Yusuf, D. D. 2011. Role and Challenges of Agricultural Mechanization in Meeting the Needs of Tomorrow's Agriculture in Nigeria. A Lead Paper in Farm Power and Machinery delivered at the 11th International Conference and 32rd Annual Conference of the Nigerian Institution of Agricultural Engineers (NIAE) held at Ilorin, October, 17-20, 2011. Pp. 13-42. ■■

# Agricultural Mechanization Today in Nigeria in Relation to Sustainable Development Goals



by  
Akindele Folarin Alonge  
Professor  
Dept. of Agricultural and Food Engineering,  
University of Uyo,  
Uyo, Akwa Ibom State, NIGERIA  
Email: falonge6@gmail.com

## Introduction

There has been increase in agricultural production from 2015 following recession in Nigeria. The reason is because the government identified agriculture as one of the areas to diversify economic to avoid decline in economic growth of the nation (EGRP). From the current structure of the Nigerian economy, agricultural sector is the dominant sector contributing about 25.13% to GDP (NBS Report 2019). According to the report, crop production remains the major driver of the sector, accounting for 89.84% of nominal agriculture GDP. Agriculture sector contribution to real GDP in 2018 was recorded at 25.13%, up

from 25.08% in 2017. The value of Agriculture imports declined -3.9% from N886.7bn in 2017 to N851.6bn in 2018 (one US \$ – 377 N).

The Sustainable Development Goals (SDGs), otherwise known as the Global Goals, are a universal call to action to end poverty, protect the planet and ensure that all people enjoy peace and prosperity.

The 17 Sustainable Development Goals (SDGs) (**Fig. 1**) with 169 targets are directly or indirectly related to engineering and more specifically agriculture. There are 196 countries involved with 2030 as ending year. Engineers and particularly agricultural engineers have great role to play in the scheme of things. No serious agricultural production can

take place without mechanization

The Federal Government of Nigeria is to start up a program, “The Green Imperative”, which will lead to the establishment of 632 farm mechanization centres in the country. The government said the mechanization centres will support food production in all the local government areas of the country so as to boost the nation’s food sufficiency. The government is ready to revolutionize the agricultural sector, strengthen the nation’s economy as well as bring in many other benefits through the Green Imperative program. It is intended that the program will strengthen food security, create massive jobs, transfer technology, revive or reinvigorate many assembly plants, strengthen the economy, save scarce resources, mechanize farming and lead to the emergence of the value-added agriculture, among other benefits.

The Green Imperative Program is a Nigeria-Brazil led bilateral agriculture development program launched by the Vice President, Professor Yemi Osibajo in January 2019, with the aim to strengthen the productive capacity of smallholder farmers through provision of tractors. African agriculture relies mostly on direct human energy due to the lack of machines and this has negative effects in the agricultural production level. In Nigeria, majority of smallholder farmers are often

Fig. 1 Sustainable Development Goals



too poor to pay for farming machines, therefore the size of farmland covered with the human effort remains small.

The Green Imperative Program, expected to be funded by Brazil and other international bodies, is worth US\$1.2 billion and is billed to be implemented over a period of 5-10 years. The funding from the Development Bank of Brazil (BNDES) and Deutsche Bank with insurance provided by Brazilian Guarantees and Fund Managements Agency (ABGF) and the Islamic Corporation for Insurance of Export Credit (ICIEC) of the Islamic Development Bank (IsDB) and coordinated by Getulio Vargas Foundation (FGV).

With the government's plans to establish these mechanization centres across the country, there will be increased productivity, timeliness of operation and improved quality of farm produce.

"The Nigerian technical team also embarked on a study tour of three African countries (Ghana, Kenya and Senegal) where MFIP is being implemented to study their challenges as well as their success or failures. The Nigerian technical team has also visited the selected assembly plants in the six geopolitical zones to determine in-country capacity to handle the assembly of a CKD-based program of this magnitude," the minister said.

The minister listed other benefits of the planned Green imperative program to include assembly plants for tractors and other implements.

The program will import the completely knocked down (CKD) parts of about 5,000 tractors and numerous implements (for local assembly) annually for ten years and reactivation of six motor assembly plants in the six -geopolitical zones of the country for assembling tractors and other implements.

Though it has been observed that the National Centre for Agricultural Mechanization (NCAM) established by the government to address agri-

cultural mechanization issues was not involved in all these. The body of Agricultural Engineers through their professional body; Nigerian Institution of Agricultural Engineers (NIAE) were also not involved. There are other observations noted on the project. The challenge now is that Agricultural Engineers and other stakeholders will have to find a way of getting involved in these centres and to train personnel and operators of the centres.

### The Place of NCAM in Boosting Agricultural Production

Government should focus on NCAM that has the mandate to mechanize Nigeria agriculture and create enabling environment to fulfil this. They will not only help in boosting food production but provide jobs directly and indirectly to several millions of youth and women but also help in creating wealth. NCAM has the capacity and potential, and should be re-modelled, to become a Public Private Partnership (PPP) self-funding Centre with proven sources of income from the following;

- (i) mandatory import charge as a percentage of the cost price of all the agricultural equipment imported into the country to fund its testing and certification of such machinery and equipment (this 'low hanging fruit' is proposed for immediate implementation),

**Fig. 2** NCAM developed 30 hp three-wheel tractor (Triketor) with mounted plough



- (ii) intellectual property management activities, commercialization and scaled production of home-grown technologies from local R and D and innovation
- (iii) providing training and support for farmers, agro-processors, fabricators, and manufacturers, etc,
- (iv) growing, spinning-off and developing SMEs in all stages of the agricultural value chain - mechanized niche farmers, agro-processors, fabricators, and commodity merchants, and
- (v) forging better collaboration between academia, research institutions and the agro-industry.

The potential for NCAM to thrive and continue to excel is high. It is also noteworthy that through her testing and certification activities, the Centre has been saving unsuspecting farmers/users from the pains of being ripped-off by importers of unfit or deficient foreign technologies. **Figs. 2** and **3** show some of the equipment developed at NCAM.

### REFERENCES

- Alonge, A. F. 2019. Innovations in Agriculture and Technology for sustainable food sufficiency. The Nigerian Engineer magazine, pages 5 -9, November 2019
- Faborode, M. O. 2019. Agricultural Mechanization and Food Production for Youth Empowerment: Engineering Sustainable Development (Continued on page 162)

**Fig. 3** NCAM developed 45 hp four wheel mini tractor with complete associated implements



# Draft Efforts' Behavior of a Vibratory Tool to Different Forward Speeds



by  
Luis Orlando Marin Cabrera  
Specialist and Professor  
Faculty of Technical Sciences,  
Agrarian University of Havana,  
Mayabeque, CUBA. CP: 32700  
luismc@unah.edu.cu



Arturo Martinez Rodriguez  
Professor  
Faculty of Technical Sciences,  
Agrarian University of Havana,  
Mayabeque, CUBA. CP: 32700  
armaro646@gmail.com



Armando García de la Figal Costales  
Professor  
Faculty of Technical Sciences,  
Agrarian University of Havana,  
Mayabeque, Cuba. CP: 3270  
areloy@unah.edu.cu



Yanoy Morejón Mesa  
Professor  
Faculty of Technical Sciences,  
Agrarian University of Havana,  
Mayabeque, Cuba. CP: 32700  
ymorejon83@gmail.com

## Abstract

In the present work is analyzed the draft efforts behavior at different forward speeds of a vibratory tool (curved bent leg and logarithmic profile subsoiler) tilling a loam clay soil (ferrallitic) by means of a lineal dynamic study to a simulation model of the soil-farming tool interaction developed by the finite element method and a comparative analysis of both process (non-vibrating and vibrating). The soil was considered homogeneous and the soil-tool interaction was modeled with the lineal extended Drucker-Prager constitutive relationship model. The results showed the lineal behavior of the nodal stresses' increase with the forward speed increase for the three analyzed speed levels. The biggest values in the nodal stresses are located in the tip of the tool, so much non- vibrating as vibrating process.

## Introduction

All the operations of soil tillage

in the agricultural production are considered dynamic processes (Li et al., 2015). The movement of the tool through the soil causes the propagation of stresses waves and areas of elastic and plastic deformation (Kushwaha and Shen, 1995), also, the draft efforts of the farming tools are affected by several factors, such as the geometry, working depth and forward speed (Gao et al., 2015). Analytic and empiric models are even used to solve applications of the soil-tool interaction (McKyes, 1985), but many of them are in 2D (Davoudi et al., 2008; Tamás and Jóri, 2009) and theoretically appropriate alone for wide tools (Hettiaratchi et al., 1966).

The latest advances in the calculation techniques allow the employment of the numerical methods for the design and analysis of the farming tools, among them the finite element method, with which several investigation works have been reported (Yong and Hanna, 1977; Armin et al., 2015; Bentaher et al., 2013; Fielke, 1999; Jafari et al., 2006; Chi and Kushwaha, 1993; Li

et al., 2015; He et al., 2016; Topakci et al., 2010; Biriş et al., 2016; Gheorghie et al., 2016; Constantin et al., 2019). Models 3D have been developed using the finite elements method for dynamic analysis (Abo Elnor et al, 2003; Mollazade et al., 2010; Onwalu and Watts, 1998) and the analysis of the behavior of narrow tillage tools (Payne, 1956; McKyes, 1978; Perumpral et al., 1983). Most of those models have been used for slow tools and they have not kept in mind the speed effects. Many tillage operations are carried out to speeds between 4 and 10 km.h<sup>-1</sup>, where the soil efforts on the tool are expected they vary with the speed. The finite element method has shown to be able to simulate different forms of farming tools and the dynamic effect of the forward speed (Abu Hammdeh and Reeder, 2003).

The general objective of this work is to analyze, in a comparative way, using the lineal form of the extended Drucker-Prager constitutive relation model and the 3D simulation model of soil-farming tool interaction, the dynamic effects of the

forward speed in the draft efforts of a subsoiler, so much non- vibrating as vibrating process.

### Methods

**Soil Model:** Different yield criteria and their extended forms (lineal, hyperbolic and exponential) have been used for the simulation of the mechanical behavior of soil under external loads (Ibrahmi et al., 2015). In the present work the soil was modeled as continuous, homogeneous and elastoplastic using the lineal extended Drucker-Prager model (Fig. 1), employee with good results in previous investigations for (Herrera et al., 2008a and b) for this type of soil. The wide use of this model is due to its simplicity and the little quantity of necessary parameters for its implementation (González et al., 2014).

**Properties and Soil Parameters:** The soil object of this study was classified as Rhodic Ferralsol (Hernández et al., 2015), with a density of 1,120 kg.m<sup>-3</sup>, index of plasticity of 36.2% and organic matter content 2.7%. The Table 1 shows the values of the properties and soil parameters required by the finite element model obtained on base of the results of: García de la Figal (1978); García de la Figal, (1991); Herrera et al. (2008a and 2008b) and De la Rosa et al. (2014).

**Simulation Model of Soil-farming Vibratory Tool Interaction:** It is formed by the vibratory subsoiler bent leg, the soil block and the in-

teraction surfaces of both (Fig. 2). The bent leg is moving in the X axis direction, at constant working depth (a<sub>e</sub> = 0.3 m). Have freedoms of angular movement (phase angle θ) and lineal movement (axes X and Y). The force applied to the same one is 15,000 N. The rake angle of the share is 25° and the width of the same one b<sub>0</sub> = 0.078 m. The area of the tip surface is 0.0017 m<sup>2</sup> and the area of the attack surface 0.018 m<sup>2</sup>. The soil block has movement restrictions in the lateral, later and inferior surfaces. Their dimensions are: long L (2 m), height H (0.9 m) and wide B (1 m). The width of the cut soil prism coincides with the width of the tip (b<sub>0</sub> = 0.078 m). An increase of dimensions of the cut soil prism beyond those assigned, as a result of the interaction with the bent leg, it can be rejected (Ibrahmi et al., 2015; Marín and García de la Figal, 2019). The forward speed was simulated at three levels (V<sub>m</sub> = 0.5; 0,85 and 1.2 m.s<sup>-1</sup>), for both process

(non- vibrating and vibrating).

### Results and Discussion

**Draft Efforts in the Tip Nodes to Different Forward Speeds:** In the Fig. 3 the values of the draft efforts are shown in the nodes of the tip (so much vibrating process as non-vibrating) of the simulation model. When the tool works with vibrations (Fig. 3a), the draft efforts reaching a value of 3.,1 MPa (5.27 kN) to a speed of 0.5 m.s<sup>-1</sup>. Similar values (5.5 kN) were obtained by Ibrahmi et al. (2014) analyzing by finite element the effect of the working width in the cultivation forces, using the same constituent model. Also Abbaspour-Fard et al. (2014) obtained similar values to a speed of 2 km.h<sup>-1</sup> (0.55 m.s<sup>-1</sup>), rake angle 45° and working depth 400 mm, analyzing the behavior of tillage tools to different forward speeds. Other investigation works have reported

**Table 1** Properties and soil parameters required by the finite element model

Property or parameter	Symbol	Dimension
Internal friction angle	$\varphi$	5°
Modulus of elasticity	$E$	1,575 kPa
Shear modulus	$G$	1,793 kPa
Poisson's ratio	$\nu$	0,22
Cohesion	$c$	15 kPa
Humidity	$Ha$	27%
Density	$\gamma$	1.05 g.cm <sup>-3</sup>
Shear efforts resistance	$\tau$	190 kPa
Traction limit of soil	$\sigma_t$	20 kPa
Compression limit of soil	$\sigma_c$	480 kPa
Elastic limit of soil	$\sigma_e$	42 kPa
Soil-metal friction angle	$\delta$	30.5°
Type of soil	Linear elastoplastic	

**Fig. 1** Yield criteria of the linear extended Drucker-Prager model: a) meridional plane b) main stresses plane

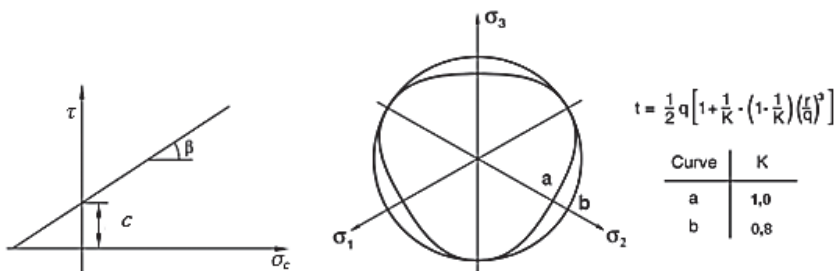

**Fig. 2** 3D simulation model of system

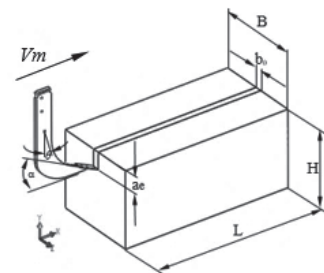

results in agree with these (Mouazen and Néményi, 1999; Ibrahmi et al., 2013; Odey and Manuwa, 2016).

However, to a forward speed of 0.85 m.s<sup>-1</sup> and 1.2 m.s<sup>-1</sup>, the traction efforts end up reaching 5.8 MPa (9.86 kN) and 6 MPa (10.2 kN) respectively, being shown the dynamic effects of the same one (Abu Hammdeh and Reeder, 2003; Soeharsono and Radite, 2010) when one works in a range among 4-10 km.h<sup>-1</sup> (1.1-2.8 m.s<sup>-1</sup>). Similar values (10.9

kN) were obtained by Davoudi et al. (2008), carrying out analysis 2D in finite element of a contact model between a plane tool and the soil, using the same constituent model. Also Ibrahmi et al. (2015) obtained the similar result (10.3 kN) in sandy loam soil, to a forward speed of 1 m.s<sup>-1</sup> and working depth of 150 mm. Other authors have obtained similar results for sandy loam soil (Karoombonyanan et al., 2007; Shahgoli et al., 2010), clay-loam soil

(Topakci et al., 2010) and compacted (Zhang et al., 2016).

Working the tool with vibrations (Fig. 3b), the draft efforts in the nodes of the tip reach approximate values of 0.82 MPa (1.394 kN) to a forward speed of 0.5 m.s<sup>-1</sup>. Similar values were obtained by Abo Elnor et al. (2004) analyzing the effect of the mesh density in the predicted draft forces, in dry sandy soil, to 50 mm of displacement. Also Jafari et al. (2006) found coincident results to 30 mm of displacement, rake angle of 15° and using the same constituent model. In other studies, has met similarity with these results for loam soils (López et al., 2019; Marín and García de la Figal, 2019).

When the forward speeds arrive to 0.85 m.s<sup>-1</sup> and 1.2 m.s<sup>-1</sup>, the draft efforts in the nodes take values of 0,88 MPa (1.496 kN) and 0.91 MPa (1.547 kN) respectively. Similar results obtained Kalantari et al. (2014), analyzing the influence of the forward speed and the working depth in the soil-share interaction forces, with rake angles of 60, 75 and 90 degrees, speeds range among 0.75-1.75 m.s<sup>-1</sup>, in loam-sandy soil, to depths of 100, 150 and 200 mm. Other authors have found similar results for loam-sandy soils (Onwalu and Watts, 1998; Mouazen and Néményi, 1999).

**Draft Efforts in the Nodes of the Attack Surface to Different Forward Speeds.** The same ones are shown in the Fig. 4. Working the tool without vibrations (Fig. 4a), to forward speeds of 0.5 m.s<sup>-1</sup> and 0.85 m.s<sup>-1</sup>, the draft efforts take values of 0.95 MPa (17.1 kN) and 1.05 MPa (18.9 kN).

Similar values (17 kN) were obtained by Bentaher et al. (2013), analyzing by finite elements the influence of the mesh density and the effect of the rake angle in the draft efforts of a soil-plow interaction simulation model.

However, when the speed reaches 1.2 m.s<sup>-1</sup>, the draft efforts take values near to 1.5 MPa (27 kN), reaffirming the dynamic behavior of the same one for upper speeds to 1.1 m.s<sup>-1</sup> and

Fig. 3 Draft effort in the tip nodes: I ( $V_m = 0.5 \text{ m.s}^{-1}$ ); II ( $V_m = 0.85 \text{ m.s}^{-1}$ ); III ( $V_m = 1.2 \text{ m.s}^{-1}$ )

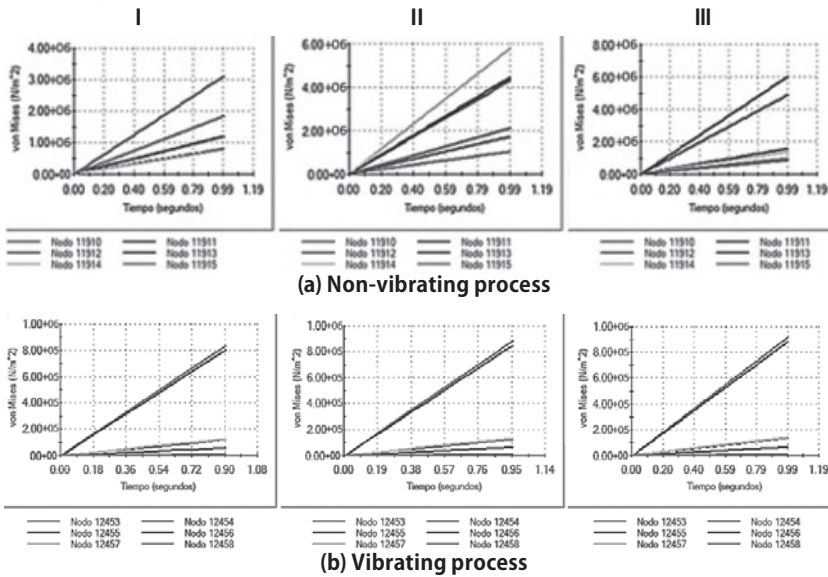
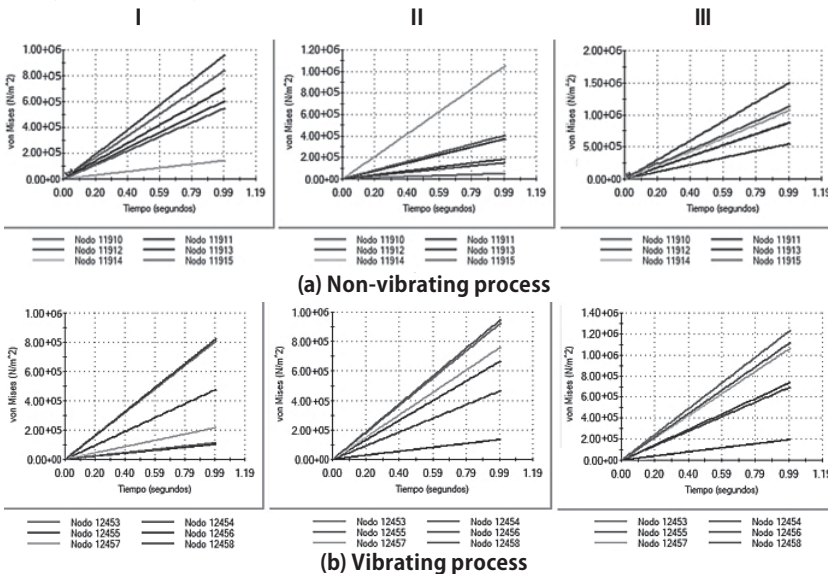

Fig. 4 Draft efforts in nodes of attack surface: I ( $V_m = 0.5 \text{ m.s}^{-1}$ ); II ( $V_m = 0.85 \text{ m.s}^{-1}$ ); III ( $V_m = 1.2 \text{ m.s}^{-1}$ )



coinciding with the results obtained by Marín et al. (2011), when they analyzed the influence of the vibration way and the working speed in the draft resistance of a harrow.

When one works with vibrations (Fig. 4b), to a forward speed of 0.5 m.s<sup>-1</sup>, the nodes of the attack surface reach a value of 0.82 MPa (14.76 kN). Abo Elnor et al. (2004) obtained similar results when they analyzed the effect of the mesh density in the predicted draft efforts of a soil-tool interaction 3D simulation model, in dry sandy soil, working depth 200 mm, rake angle 75° and 400 mm of displacement.

The draft efforts to a forward speed of 0.85 m.s<sup>-1</sup> take maximum values of approximately 0.94 MPa (17.01 kN). Similar result (18.62 kN) was obtained by Ahmadi (2016) by means of the development of a theoretical model of draft efforts calculation of a subsoiler, to forward speed 3.6 km.h<sup>-1</sup>, in loam soil. To forward speed of 1.2 m.s<sup>-1</sup>, the efforts end up reaching a value 1.22 MPa (21.96 kN).

**Behavior of the Draft Efforts.**

The Fig. 5 shows the tool draft efforts behavior to different forward speeds, in the tip and attack surface, so much vibrating process as non-vibrating. In the tip the efforts are smaller and the behavior of its increase to different speeds is linear, however, in the attack surface the efforts increase in an exponential way as the forward speed increases, due to the tool-soil contact area in this surface is bigger.

**Conclusion**

1. The draft efforts in the tip of the farming tool, so much vibrating process as non-vibrating, its behaves in a lineal way with the forward speed increase, however, in the attack surface the draft efforts increase in an exponential way.
2. The biggest draft efforts are located in the tool attack surface for

both process (vibrating and non-vibrating), due fundamentally to that the working surface area of the same one is bigger than in the tip.

3. Coinciding with several authors, the dynamic effects of the forward speed in the draft efforts of the farming tools are increased starting from the 4.0 km.h<sup>-1</sup> (1.11 m.s<sup>-1</sup>).

**REFERENCES**

Abbaspour-Fard, M. H., Hoseini, S. A., Aghkhani, M. H. and Sharifi, A. 2014. The behavior of tillage tools with acute and obtuse lift angles. *Spanish Journal of Agricultural Research*. 12(1): 44-51. ISSN: 2171-9292.

Abo-Eknor, M., Hamilton, R. and Boyle, J. T. 2003. 3D Dynamic analysis of soil-tool interaction using the finite element method. *Journal of Terramechanics*, 40(1): 51-62. ISSN: 0022-4898.

Abu-Handeh, N. H. and Reeder, R. C. 2003. A nonlinear 3D finite element analysis of the soil forces acting on a disk plow. *Soil & Tillage Research* 74: 115-124.

Armin, A., Fotouhi, R. and Szyszkowski, W. 2015. 3D finite element analysis for mechanics of soil-tool interaction. *World Academy of Science, Engineering and Technology. International Journal of Mechanical, Aerospace, Industrial, Mechatronic and Manufacturing Engineering* Vol. 9, No. 5.

Bentaher, H., Ibrahmi, A., Hamza, E., Hbaieb, M., Kantchev, G., Maalej, A. and Arnold, W. 2013. Finite element simulation of moldboard-soil interaction. *Soil & Tillage Research* 134: 11-16. ISSN: 0167-1987.

Biriş, S. Ş., Maican, E., Vlăduţ, V., Bungescu, S. T., Ungureanu, N. and Vla, D. I. 2016. Stress and strains distribution in the frame of agricultural cultivators using the finite element method. *Proceedings of the 44<sup>th</sup> International Symposium on Agricultural Engineering: Actual Tasks on Agricultural Engineering*, Opatija, Croatia: 23-26.

Constantin, G. A., Voicu, Gh., Olac, B., Ilie, F. and Paraschiv, G. 2019. Structural analysis with finite elements of a subsoiler working part. *International Symposium, ISB-INMA TEH*. Universities Polytechnic Bucharest, Faculty of Biotechnical Systems Engineering.

Chi, L. and Kushwaha, R. L. 1993. A nonlinear 3D finite element analysis of soil forces on curved tillage tools. *Canadian Agricultural Engineering* Vol. 35, No. 1,

**Fig. 5** Draft efforts behavior (F) to different forward speeds (Vm)

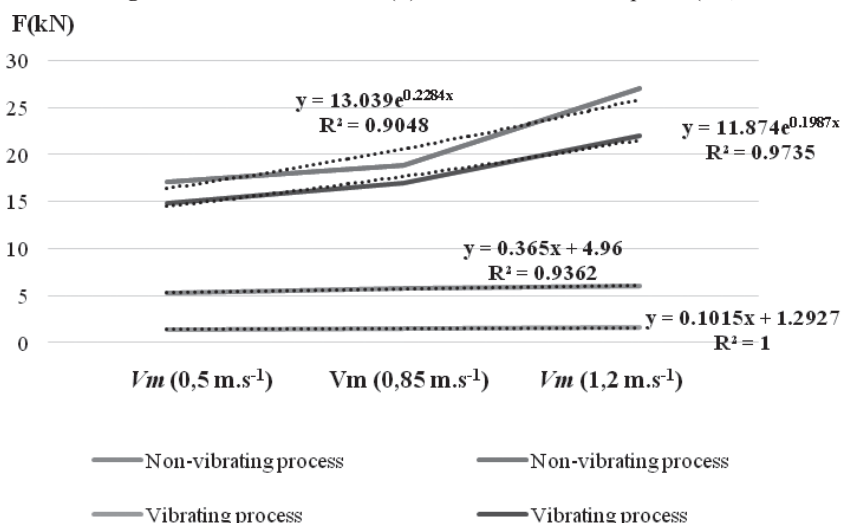



- January/February/March.
- Davoudi, S., Alimardani, R., Keyhani, A. and Atranejad, R. 2008. A two dimensional finite element analysis of a plane tillage tool in soil using a non-linear elastoplastic model. *American-Eurasian J. Agric. & Environment Sci.*, 3(3): 498-505. ISSN 1818-6769.
- De La Rosa, A. A. A., Herrera, S. M. and González, C. O. 2014. Modelos constitutivos para la simulación de la respuesta mecánica de los suelos agrícolas mediante el método de elementos finitos (MEF). *Revista de Investigaciones*. 1, (1).
- Fielke, M. J. 1999. Finite element modelling of the interaction of the cutting edge of tillage implements with soil. *J. Agric. Eng. Res.* (UK). 74: 91-101.
- Gao, Q., Chen, Y., Zhou, H. and Sadek, M. A. 2015. Simulation of a seed opener using the discrete element method (DEM). *Agric Eng Int: CIGR Journal*, 17(3): 72-82.
- García De La Figal C., A. 1978. Estudio de la fricción suelo-metal y suelo-plástico para dos suelos cañeros cubanos. *Ciencias Técnicas. Ingeniería en Construcción de Maquinaria*. 3, 107-122.
- García De La Figal C., A. 1991. Estudio de las propiedades tecnológicas más importantes de los suelos cubanos. *Revista Ciencias Técnicas Agropecuarias*. La Habana, Cuba. 3(2): 61-77. ISSN 1010-2760.
- Gheorghe, G., Persu, C., Matache, M., Mateescu, M. and Cujbescu, D. 2016. Finite element method used in the calculation and optimization of the active parts of mulch films applying equipment, *Agricultural and mechanical engineering*, ISSN 2537-3773, pp. 629-634.
- González, C. O., Herrera, M., Iglesias, C. E. and López, E. 2014. Modelos constitutivos Drucker Prager extendido y Drucker Prager modificado para suelos Rhodic Ferralsol. *Terra latinoamericana*, volumen 32 número 4.
- He, Changbin, Yong You, Decheng Wang, Guanghui Wang, Donghui Lu and John Morris Togo Kaji. 2016. The effect of tine geometry during vertical movement on soil penetration resistance using finite element analysis. *Computers and Electronics in Agriculture* 130: 97-108. ISSN: 0168-1699.
- Hernández, A., Pérez, J., Bosch, D. and Castoro, N. 2015. Clasificación de los suelos de Cuba. Edit. Ediciones INCA, Mayabeque, Cuba, 2015, 93 p, Ed. IINCA, San José de las Lajas, Mayabeque, Cuba, ISBN: 978-959-7023-77-7.
- Herrera, S. M., Iglesias, C. E., González, O., López, E. and Sánchez, A. L. 2008a. Propiedades mecánicas de un Rhodic Ferralsol requeridas para la simulación de la interacción suelo implemento de labranza mediante el Método de Elementos Finitos: Parte I. *Revista Ciencias Técnicas Agropecuarias*, 17(3): 31-37.
- Herrera, S. M., Iglesias, C. E., González, C. O., López, E. and Sánchez, A. L. 2008b. Propiedades mecánicas de un Rhodic Ferralsol requeridas para la simulación de la interacción suelo implemento de labranza mediante el Método de Elementos Finitos: Parte II. Interfase suelo-herramienta. *Revista Ciencias Técnicas Agropecuarias*, 17(4): 50-54.
- Hettiaratchi, D. P., Wintney, B. D. and Reece, A. R. 1966. The calculation of passive pressure in two-dimensional soil failure. *J. Agric. Eng. Res.* 11(2), 89-107.
- Ibrahmi, A., Bentaher, H. and Maalej. 2013. A. Effect of the design moldboard on the tillage forces. 978-1-4673-5814-9/13©2013 IEEE.
- Ibrahmi, A., Bentaher, H. and Maalej, A. 2014. Soil-blade orientation effect on tillage forces determined by 3D finite element models. *Spanish Journal of Agricultural Research* 12(4): 941-951.
- Ibrahmi, A., Bentaher, H., Maalej, A. and Mouazen, A. M. 2015. Study the effect of tool geometry and operational conditions on mouldboard plough forces and energy requirement: Part 2. Experimental validation with soil bin test. *Computers and Electronics in Agriculture*.
- Jafari, R., Tavakoli, T., Minaee, S. and Raoufat, M. H. 2006. Large deformation modeling in soil-tillage tool interaction using advanced 3D nonlinear finite element approach. Proceedings of the 6<sup>th</sup> WSEAS International Conference on Simulation, Modelling and Optimization, September 22-24. pp. 6, Lisbon, Portugal.
- Kakantari, D., Moenifar, S. A. and Mousavi-Seyedi, R. 2014. Influence of tillage depth, penetration angle and forward speed on the soil/thin-blade interaction force. *Agric Eng Int: CIGR Journal*, 16(1): 69-74.
- Karoonboonyanan, R., Salokhe, V. M., Niyamapa, T. and Nakashima, H. 2007. Vibration effects on the performance of a single-shank subsoiler. *Agricultural Engineering International: the CIGR E journal*. Manuscript PM 07 018. Vol. IX.
- Kushwaha, R. L. and Shen, J. 1995. Finite element analysis of the dynamic interaction between soil and tillage tool. *Transactions of the ASAE (USA)* 37(5): 1315-1319.
- Li, M., Zhang, Q., Wang, H., Sun, H. and Tong, J. 2015. A 3D finite element simulation analysis of the soil forces acting on a rotary blade. *Transactions of the ASABE* Vol. 58(2): 243-249. *American Society of Agricultural & Biological Engineers*. ISSN 2151-0032 DOI 10.13031/trans.58.10732.
- López, B. E., Tijskens, E., González, O., Herrema, M., Lorenzo, J. D. and Ramon, H. 2019. Simulación de la descompactación de un suelo arcilloso empleando el método de elementos discretos. *Revista Ciencias Técnicas Agropecuarias*, Vol. 28, No. 2, abril-junio, E-ISSN: 2071-0054.
- Marín, C. L. O., Leyva, S. O. and

- Herrera, S. M. 2011. Efecto del modo de vibración y la velocidad de trabajo en la disminución de la resistencia traccional de los órganos escarificadores vibratorios. *Revista Ciencias Técnicas Agropecuarias*. Vol. 20, No.3.
- Marín, C. L. O. and García de la Figal, C. A. E. 2019. Model of soil – tillage tool interaction using finite element method. *Revista Ciencias Técnicas Agropecuarias*. ISSN -1010-2760, E-ISSN: 2071-0054, Vol. 28. No. 4 (October-November-December, pp. 40-50).
- Mckyes, E. 1978. The calculation of draft forces and soil failure boundaries of narrow cutting blades. *Trans. ASAE* 21 (1), 20- 24.
- Mckyes, E. 1985. Soil cutting and tillage. Amsterdam. Ed. Elsevier. 217p.
- Mollazade, K. 2010. Application of dynamical analysis to choose best subsoiler's shape using ANSYS. *New York Science Journal*, 3(3).
- Mouazen, A. M. and Neményi, M. 1999. Finite element of subsoiler cutting in non-homogeneous sandy loam soil. *Soil & Tillage Research (UK)* 51: 1-15.
- Odey, S. O. and Manuwa, S. I. 2016. Design steps of narrow tillage tools for draught reduction and increased soil disruption – a review. *Agric Eng Int: CIGR Journal*, 18(1): 91-102.
- Onwualu, A. P. and Wattes, K. C. 1998. Draught and vertical forces obtained from dynamic soil cutting by plane tillage tools. *Soil and Tillage Research*, Vol. 48, Issue 4, 27, Pages 239-253.
- Payne, P. C. J. 1956. The relationship between the mechanical properties of soil and the performance of simple cultivation implements. *J. Agric. Eng. Res. (UK)* 1(1): 23-50.
- Perumpral, J. V., Grisso, R. D. and Desai, C. S. 1983. A soil-tool model based on limit equilibrium analysis. *Trans. ASAE* 26 (4), 991-995.
- Shahgoli, G., Fielke, J. M., Desbilles, J. and Saunders, C. 2010. Optimizing oscillation frequency in oscillatory tillage. *Soil & Tillage Research* 106: 202-210.
- Soeharsono, G. and Radite, P. A. S. 2010. Analytical study of self-excited vibration on single degree of freedom vibratory-tillage. *ARPN Journal of Engineering and Applied Sciences* 5(6): 61-66.
- Tamás, K. and Jóri, I. 2009. FEM analysis of the soil-tool (sweep) interaction. *Journal of Agricultural Machinery Science*, 5(4), 435-444.
- Tamás, K., Jóri, I. and Mouazen, A. M. 2013. Modelling soil-sweep interaction with discrete element method. *Soil & Tillage Research* 134: 223-231.
- Topakci, M., Celik, H. K., Canakci, M., Rennie, A. E. W., I. Akinci, I. and Karayel, D. 2010. Deep tillage tool optimization by means of finite element method: Case study for a subsoiler tine. *Journal of Food, Agriculture & Environment*, Vol.8 (2).
- Young, R. N. and Hanna, A. W. 1977. Finite element analysis of plane soil cutting. *J. Terramech.* 14 (3), 103-125.
- Zhanh, X. R., Wang, C., Chen, Z. H. and Zeng, Z. W. 2016. Design and experiment of a bionic vibratory subsoiler for banana fields in southern China. *Int J Agric & Biol Eng*, 9(6): 75-83. ■■

(Continued from page156)

## Agricultural Mechanization Today in Nigeria in Relation to Sustainable Development Goals

- ment. Paper presented at the 2<sup>nd</sup> Engr. Kashim Abdul Ali Distinguished Lecture held at Faculty of Engineering, Edo State University, Iyamho, Nigeria. August 1, 2019. Pp 21.
- Olorunfemi, I. A. 2019. Agricultural Engineering: The Brain Box for Food Sovereignty and National Development. The Nigerian Society of Engineers (NSE) October Lecture held at NSE National Engineering Centre, Abuja, Nigeria pp 86.
- NCAM. 2019. National Centre for Agricultural Mechanization. <https://ncamng.org/mandate/> Accessed June 5, 2020. ■■

# CONGRATULATORY MESSAGE

## for **AMA** 50<sup>th</sup> Anniversary



A. F. Alonge

**International Commission of Agricultural and Biosystems Engineering:** **Akindele Folarin Alonge**, President; **Remigio Berruto**, Incoming President; **Chen Zhi**, Past President; **Claus Sørensen**, Workgroup Coordinator; **Fedro S. Zazueta**, Secretary General

On the 50<sup>th</sup> Anniversary of AMA Magazine On behalf of the membership of CIGR, the CIGR Presidium extends its most heartfelt congratulations to AMA Magazine in reaching the important milestone of continuous 50 years of publication, and especially to its Chief Editor for the past 25 years Mr. Yoshisuke Kishida. CIGR recognizes that knowledge and technology advances must reach wide audiences for society at large to benefit from these developments. The importance of ensuring that all members of the agricultural community, including farmers, service providers, industry, researchers, and educators are well informed and have access to new developments cannot be undervalued. AMA has, for the past 50 years, consistently been an important contributor to ensuring that advances in agricultural and biological engineering are extended to a wide audience so they can be implemented in field applications that bring about improvements in quality, quantity and sustainability of food and fiber production systems. The agricultural and biosystems engineering community looks forward to the continued contributions and success of AMA.

\* \* \*



**Umezuruike Linus Opara:** Co-editor, South Africa; Distinguished Professor, PhD CEng CFS, DST-NRF South African Research Chair in Postharvest Technology, Editor-in-Chief, Int. J. Postharvest Technology & Innovation, Postharvest Technology Research Laboratory, Faculty of AgriSciences, Stellenbosch University

Congratulations on this important milestone.

AMA continues to be the leading international journal on agricultural mechanization; the impact on agricultural engineering research and education in the developing world has been tremendous, especially in Africa, Asia, Middle East and Latin America.

I would be most delighted to send a message on this special celebration of AMA. We are looking forward to MORE Golden Jubilees ahead.

\* \* \*

**Section III of International Commission of Agricultural and Biosystems Engineering:** **Francisco Rovira-Más**, Chair; **Markus Demmel**, Vice Chair; **Andrew Guzzomi**, Secretary; **Qin Zhang**, Honorary Chair; **John K. Schueller**, Honorary Chair

On behalf of the members of Section III (Engineering for Plant Production) of the International Commission of Agricultural and Biosystems Engineering (CIGR) we want to sincerely congratulate you on the significant milestone of fifty years of publishing Agricultural Mechanization in Asia, Africa, and Latin America (AMA).

Your journal's achievements in promoting agricultural mechanization, especially in developing countries, are substantial and significant. The issues of AMA have promoted the sharing of information between countries and the betterment of food, feed, fiber, and fuel production and distribution. Your journal's contributions to helping solve the needs of human society have been remarkable. According to the United Nations, and other international institutions, population growth for the next fifty years is going to be exponential, and most of it is going to take place in Asia, Africa, and Latin America. As a result, the role of AMA for the next fifty years is going to be even more important for the wellbeing of the world, mainly in developing countries.

Best wishes for continued success.

\* \* \*



C. L. Engler October 2020

**American Society of Agricultural and Biological Engineers:** **Candice L. Engler**, President; **Paul H. Heinemann**, President-Elect; **Sue E. Nokes**, Past President; **Darwin J. Drollinger**, Executive Director

American Society of Agricultural and Biological Engineers are please to congratulate the AMA on the occasion of its 50<sup>th</sup> Anniversary and recognize AMA for its ongoing commitment and lasting contributions to promote agricultural mechanization in the developing world.

\* \* \*

**Lalit R. Verma:** Ph.D., P.E., Professor and Head, ASABE Foundation President, ASABE Past-President, ASABE Fellow – 1999

It is my pleasure and honor to extend my heartfelt congratulations on the publication of the Anniversary Issue

of AMA in November 2020. You have made AMA a very high-profile journal in the agricultural machinery arena on the global stage. Your rich history of engagement with the American Society of Agricultural and Biological Engineers (ASABE) and support of its Global Initiative are highly appreciated and recognized.

The AMA journal you publish and its worldwide circulation is commendable. Your leadership and engaged participation in CIGR, ASABE Foundation and iAABE are well recognized. I respect your strong support of the ASABE Global Initiative. Your keen engagement and strong support for the Global Food Security Conference in South Africa in 2016 and the Global Water Security Conference in India in 2018 are noteworthy. You have been honored by many organizations such as bestowing of the grade of "Fellow" in ASABE, CIGR, etc.. You deserve high praise for the many high-profile contributions to the Agricultural Machinery enterprise not only in Japan, Asia but also globally.

Many more years of continued success is wished for AMA and Shin-Norinsha Co., Ltd. Heartiest Congratulations and the Very Best Wishes on the AMA Anniversary Issue.

\* \* \*

**Club of Bologna: Paolo Balsari, President; Marco Fiala, Secretary General**

*Club of Bologna message for the AMA special Issue on "Sustainable Development Goals (SDGs) and Agricultural Mechanization in the world"*

The idea to create the *Club of Bologna* arose in 1988 from Prof. Giuseppe Pellizzi (Milan University, Italy). He was deeply convinced that the agricultural machinery and mechanization sector was so central for human development that it had to benefit from a free and open exchange of ideas among leading personalities in all the Countries of the world.

The CoB is at present made up of 86 members from 27 countries, representing universities and research centers, agricultural machinery manufacturers and their Associations, experts and consultants.

The *Club of Bologna* mission is "the study and definition of strategies for the development of agricultural mechanization worldwide, taking into consideration technical, economic and social advances and changes in agriculture on an international level".

This mission is entirely consistent with the activities carried out by the AMA magazine. During these 50 years of activity this important scientific journal was initially interested only in agricultural mechanization practiced in Southeast Asia, then moving on 1981 to consider and promote the mechanization in the whole of Asia, Africa and Latin America were progress in higher level of agricultural mechanization is essential.

At the moment there is an urgent need to take on a new holistic vision of world agricultural mechanization, considering it not only for primary products, but as an essential component of the entire production chain with a view to sustainability and conservation of natural resources.

For these reasons, an appreciation to AMA journal for organize for its 50<sup>th</sup> anniversary this special Issue on "Sustainable Development Goals (SDGs) and Agricultural Mechanization in the World" where all these relevant aspects concerning the future of the agriculture mechanization around the world are considered.

Many thanks also to Yoshisuke Kishida, the AMA Chief Editor, who since 25 years is an active Member of the Club of Bologna and of its Management Committee. He has contributed to the constant growth and development of the Club, also disseminating its activities through the AMA journal.

\* \* \*

**Ettore Gasparetto:** Former - Full Professor of Agricultural Mechanization, Department of Agricultural Engineering, University of Milan, Italy - President of the Club of Bologna

I followed the present AMA magazine since its foundation, through its name expansion from South East Asia up to the today Asia, Africa and Latin America.

For a number of years and even at present the AMA has been the only international magazine open to contributions coming from developing countries.

AMA has been able to allow to local researchers and scientists to present their studies, investigations and machinery prototypes to all over the world, in such a manner that discussions, improvements and knowledge could ameliorate the agricultural machinery and mechanization in these continents.

As a consequence I wish that AMA may continue to publish contributions from developing countries for the future half century.

\* \* \*



**Peter Schulze Lammers:** Prof. Dr.-Ing; University of Bonn, Germany

As highly recognized international scientific journal the AMA contributed assertively to the community of Agricultural Engineering in the Asian, African and Latin American regions. The journal transformed effectively knowledge from science and research to stakeholders in a wide range of agriculture and contributed in the last 50 years to a successful evolution of agricultural mechanization. By this impact the agriculture became more effective and succeeded to reduce hunger, drudgery as well as environmental problems. Yoshisuke Kishida as editor in

chief always attracted professional proven authors and respected contributing editors. In future the AMA journal is an invaluable media to disseminate innovative research results among the scientific community, new technologies into agriculture and to attract young professionals to sustain the AgEng-community.

Best regards from Bonn/Germany

\* \* \*

**Osamu Kitani:** Prof. Dr. Emeritus, University of Tokyo, Former President of CIGR, Former President of Japanese Society of Agricultural Machinery

I'd like to express my heartfelt congratulation on AMA 50<sup>th</sup> anniversary.

For many years, your company have made a tremendous contribution for the development of agricultural mechanization in Japan and around the world.

I'd like to express my deepest respect and heartfelt words for your contributions and pray for your continued prosperity.

I believe that your company will continue to be successful and grow in the world.

Personally, I have also been involved in research and education for agricultural mechanization in Japan and around the world at universities.

I would like to express my sincere gratitude to your company for all your help since I was a student at the university of Tokyo.

\* \* \*

**Takemi Machida:** Honorary Advisor of Japanese agricultural Informatics Society, Professor Emeritus, Ibaraki University

Farm maintenance, infrastructure and irrigation of the farm are important for food production in Asia and Africa today, but the most important is the role of agricultural machinery.

Stable food production is possible by performing appropriate farming according to the appropriate work time of each crop.

Therefore, it is important to actively promote research on agricultural machinery and working machines that take into consideration the climate and soil of each region of Asia, Africa and Latin America.

In that sense, the significance of AMA's existence as an international academic journal has a large role to play in information sharing across regions, and AMA has become an indispensable place for academic presentations by researchers in these regions.

During this time, Yoshisuke Kishida, the president of Shin-Norin co., ltd. is convinced that AMA was launched and the provision of funds and human resources and contributions over the last 50 years have been a major driv-

ing force in promoting agricultural mechanization around the world.

AMA has the highest evaluation as an academic journal related to agricultural engineering, and the expectations of researchers are high.

We pray for further development toward the 60<sup>th</sup> and 70<sup>th</sup> anniversary.

\* \* \*



**Gajendra Singh:** Patron, Indian Society of Agricultural Engineers

My 50-Year Journey with AMA and Mr Yoshisuke Kishida

My association with Mr Yoshisuke Kishida started in January 1971 when we met at the International Rice Research Institute, Los Banos, Philippines during a seminar on Farm Mechanization. The first issue of AMA was published in April 1971 with the title of "Agricultural Mechanization in Southeast Asia" changed to "Agricultural Mechanization in Asia" from 2<sup>nd</sup> issue. I published my first paper in AMA in 1974 on "Farm Mechanization and Crop Yield" and a second paper in 1976. In 1975, I joined the Asian Institute of Technology, Thailand where students came from all over Asia including a few from Europe, Africa and North America. Many of my graduate students conducted research related to mechanization in their home countries and we published many papers in AMA which in 1981 changed its title to "Agricultural Mechanization in Asia, Africa and Latin America". Over last five decades AMA has been the most relevant journal in the field of agricultural mechanization in developing countries and an extremely rich source of literature in the field. Given below is the list of year wise countries with papers related to mechanization published by me (as author / co-author) while working at AIT.

- 1978 Bangladesh
- 1979 Philippines, Thailand
- 1980 Thailand, Philippines
- 1981 Philippines, Malaysia, Bangladesh
- 1982 Indonesia
- 1983 Pakistan
- 1984 Mechanization in Selected South Asian Countries
- 1986 India, Malaysia
- 1987 India
- 1988 Pakistan
- 1989 India
- 1990 Thailand, India
- 1992 India, Nepal
- 1993 India
- 1995 Nepal
- 1996 Bhutan, Pakistan
- 1997 Kenya
- 1999 India, Thailand
- 2000 Thailand

2001 Laos, India

2003 Thailand

In 1991 the Asian Association for Agricultural Engineering (AAAE) was established and I became the Founder President with Mr Yoshisuke Kishida as Vice President. Later I joined Club of Bologna where Mr Kishida and I are serving as members of the Management Committee. We are both members of the CIGR Executive Board. We have been meeting very often at the ASABE meetings and other agricultural engineering international meetings.

I retired from AIT in 2004 and returned to India and got involved in the activities of the Indian Society of Agricultural Engineers (ISAE). Mr Kishida is a very strong supporter of ISAE and has attended a number of annual conventions of ISAE in addition to his other business trips to India.

The last paper I (with Bing Zhao) published in Special Issue of AMA was in 2016 with title "Agricultural Mechanization Situation in Asia and the Pacific Region". It was shown that during 1990 to 2013 the farm power available (kW/ha) from tractors, power tillers, irrigation pumps and harvesters in many Asian countries (China, India, Thailand Vietnam) increased about three times resulting in doubling the yields of the cereal crops. There is need for developing appropriate agricultural mechanization for African countries. While there was severe criticism of mechanization as displacing labor and creating unemployment in 1970s, now there is a shortage of labor to do farm work. Agricultural mechanization has made significant contributions towards increasing labor and land productivities, increasing use efficiencies of inputs, improving timeliness and reducing drudgery of farm operations. Agricultural mechanization has contributed significantly to improved food security and reduced poverty. During this COVID 19 pandemic it is the agricultural mechanization which has protected the agriculture sector from serious negative impacts as has happened to other sectors of economy.

In conclusion I would like to say that during five decades, AMA has made tremendous contribution in dissemination of mechanization technologies throughout the world, specially among developing countries. I wish that AMA will continue to do so for many decades in future.

\* \* \*

**Amir U. Khan:** Co-editor, Pakistan; Former director of Agricultural Engineering, IRRI; 10127 Ford Road, Perrysburg, OH. 43551. USA.

The AMA journal is a unique publication that has been serving the cause of Agricultural Mechanization in the Developing Countries for the last fifty years. In the late sixties when I was associated with the International Rice Research Institute in the Philippines, Mr. Yoshisuke

Kishida and his late Father, Mr. Yoshikuni.

Kishida discussed the idea of starting an English language journal for Asian Agricultural Mechanization.

While, I was very supportive of the idea, I had never imagined the tremendous progress the AMA has been able to achieve.

I must say that the hard work and perseverance of Mr. Yoshisuke Kishida and his staff at Shin Norinsha Co. Ltd. deserve a lot of credit. I am confident the Agricultural Engineering community in Asia, Africa and Latin America will continue to benefit immensely from this publication.

At this moment of the AMA 50<sup>th</sup> Anniversary, I wish continued success to AMA and the Shin Norinsha Co. for many years to come.

\* \* \*

**James H. Taylor:** Ph.D.,P.E.-Retired, National Technical Advisor, Traction & Controlled Traffic

Congratulations to AMA for 50 years of service to all people. In today's world of mechanization and technology, it is difficult to remember the drudgery of farm life in many places 50 years ago. When I think of the beneficial changes in the production of food and fiber throughout the world, I think of two men: Yoshikuni and Yoshisuke Kishida.

I first met Yoshikuni Kishida in Auburn, AL in 1964. He was on one of his frequent around-the-world trips to gather information on farm machinery, and he was accompanied by his young son Yoshisuke. I was impressed by his passion for improving the lives of all people through advances in farm mechanization.

In 1970, I made my first trip to Japan where Mr. Kishida introduced me to researchers in Japanese food production. A highlight for me was visiting his home island of Hokkaido and his brother's farm. Farm culture here was quite different from the rest of Japan. They had used the horse as their source of power. We discovered their commands to guide the horses sounded very much like my Mississippi "gee" and "haw" for our mules. This visit and later ones produced research relationships that have lasted through the years. While traveling together, I got to know him as an active man who got things done, but I also enjoyed the thoughtful man who found things worth doing.

That young son I first met in Auburn in the 1960's, Yoshisuke Kishida grew to maturity along with AMA. He worked and traveled with his father and became knowledgeable of the world machinery industry and was very qualified to take full responsibility of AMA. His knowledge of the industry worldwide was unsurpassed as he continued to guide the AMA to this milestone of 50 years.

I had the pleasure of introducing Yoshisuke Kishida as a keynote speaker for "The 1985 International Conference on Soil Dynamics" in Auburn, AL as we celebrated the

50<sup>th</sup> anniversary of the "Tillage Lab". Yoshisuke had traveled all over Japan with me during several visits, introducing me to universities and research people that improved my research and enriched my life! In the past 50 years AMA has collected and distributed research information throughout the world. In so doing they have made life better for millions of people who now enjoy more and better food and produce it without the drudgery of the past.

\* \* \*



**Reynaldo M. Lantín:** Co-editor, Philippines

Feeling very proud of being one of the co-editors in the maiden issue of Agricultural Mechanization in Southeast Asia (now in Asia, Africa and Latin America) or AMA, I sincerely congratulate its publisher, Yoshisuke Kishida for his achievement in sustaining and continually improving the quality of the publication to international standards as well as in expanding its circulation worldwide. Indeed AMA has made impact in the promotion of mechanization particularly in developing countries.

Agricultural mechanization in the Philippines, if gaged by the population of four-wheeled tractors, had undergone a boom and bust phenomenon in application to sugarcane and rice production from the late 1940s to the 1980s. Land reform, loss of preferential US market for sugar and the increase in population which resulted in the reduction of farm size greatly contributed to the bust phenomenon. The large supply of agricultural labor had contributed to the decline of the use of four-wheeled tractors but brought in the power tillers particularly for wetland rice cultivation in small farms.

The current increase in industrialization has brought about a shortage of farm labor and is leading towards the revival of mechanization using four-wheeled tractors and rice combines coupled with farm clustering to achieve economies of scale. The provision of agri-technical and mechanization services by the private sector is expected to follow.

The AMA publication has played a big role in the advancement of agricultural mechanization in the developing world. Through co-editors from the three continents, the impact of the art, science, engineering and technology of agricultural machinery design and agricultural mechanization research and development as well as experiences on agricultural mechanization policies and strategies have spread to the academe, the private sector manufacturers, the policy and decision makers and finally the small farmers who benefit from the adaptations of appropriate mechanization experienced in the different countries.

\* \* \*

**Maohua Wang:** Professor, Academician of China Acad-



Minzai Li

emy of Engineering, China Agricultural University; **Man Zhang**, Dean, Professor, College of Information and Electrical Engineering, China Agricultural University; **Minzan Li**, Director, Professor, China Agricultural University, Key Laboratory of Modern Precision Agriculture System Integration Research Ministry of Education, China

On the occasion of 50<sup>th</sup> anniversary of AMA (Agricultural Mechanization in Asia, Africa and Latin America), please accept our heartiest congratulations.

Over the years, our college and our laboratory have had a close relationship with Shin-Norinsha Co., Ltd. We obtained very useful information from AMA magazine to promote the development of agricultural mechanization in China. Mr. Yoshisuke Kishida gives us a great of helps. We appreciate all your kind help and cooperation. Wish AMA more glory.

\* \* \*

**Lao Xiwen:** Professor, Academician of Chinese Academy of Engineering, Honorary President of CSAM; **Wang Bo**, President, Chinese Society for Agricultural Machinery

On the occasion of the 50<sup>th</sup> anniversary of AMA (Agricultural Mechanization in Asia, Africa and Latin America), please accept the heartiest congratulation from Chinese Society for Agricultural Machinery (CSAM).

CSAM has established the close relationship with Shin-Norinsha Co., Ltd. more than 60 years. Our exchange has been promoting the cooperation and development of agricultural mechanization both in Japan and China. We appreciate all your kind help and cooperation.

In virtue of the cooperation with AMA, we obtained many useful information from AMA magazine to promote the development of agricultural mechanization in China.

Wish AMA more glorious!

\* \* \*

**Xian Liu:** President, Chinese Agricultural Mechanization Association

On the occasion of the 50<sup>th</sup> anniversary of AMA (Agricultural Mechanization in Asia, Africa and Latin America), please accept the heartiest congratulation from CAMA, China Agricultural Mechanization Association.

CAMA has established the close relationship with Shin-Norinsha Co., Ltd. since founded in 1993. Many China delegations on agricultural mechanization, including myself, visited Japan and AMA, and these visiting and exchange has been promoting the development of agricultural mechanization in China. We also appreciate all your kind help and cooperation with CAMA.

AMA is very helpful magazine to CAMA and we ob-

tained many useful information from AMA to promote the development of agricultural mechanization in China.

Wish AMA more glory.

\* \* \*



**Gao Yuan Yen:** Former Chairman of CAAMM

First of all, warm congratulations to AMA for 50 years! AMA has provided valuable information, technology and product information for the development of agricultural mechanization worldwide, especially in developing countries, in the past 50 years.

Has made the outstanding contribution for the agricultural mechanization development.

As a loyal reader of the AMA, I have been reading every issue of the AMA carefully for many years, and have gained a lot of useful information from it, which has been very helpful in my work.

On the occasion of AMA's 50<sup>th</sup> anniversary, I would like to express my heartfelt thanks to all AMA staff! Finally, I wish AMA a better and more prosperous future!

\* \* \*

**Chen Zhi:** China Association of Agricultural Machinery Manufacturers

The agricultural machinery in Japan enjoyed rapid growth after a recovery period in the 1950s. On the basis of farmland consolidation, the technology of greenhouse seedlings raising suitable for mechanized seedling transplanting was invented, and the rice transplanter was first developed and promoted in Japan. Then, the head-feed rice harvester was invented and mechanized rice harvesting was realized. The manufacturing level of small and medium plows, especially agricultural machinery such as tractors for paddy fields, has an important position in the world, and excellent enterprises such as Kubota, Yanmar and Iseki arose and boomed. In this context, AMA was founded. In the following 50 years, it has witnessed the history and experience of Japanese agricultural machinery industry and agricultural mechanization. Today, AMA is still the Japanese media unit that provides the richest information, have the closest contact with related companies with the greatest international impact in agricultural machinery. All colleagues of the China Association of Agricultural Machinery Manufacturers and Chinese agricultural machinery manufacturing companies would like to extend our warm congratulations to the 50<sup>th</sup> anniversary celebration of AMA!

Shin-Norinsha Co. Ltd. was the earliest association dedicated to non-governmental exchanges between China and Japan after China's reform and opening up. The two parties facilitated China in sending its first group of ag-

ricultural machinery maintenance students to Japan for training.

Both of Mr. Yoshisuke Kishida's father and himself are active promoters of Sino-Japanese friendship. In Japan, Mr. Kishida has received many Chinese agricultural machinery delegations. He visits China every year, attends academic conferences, visits agricultural machinery exhibitions and Chinese companies. He also introduces many Japanese experts to China. Mr. Kishida and I have known each other for more than 30 years, participated in international conferences together, organized exchange and cooperation activities between Chinese and Japanese enterprises, exchanged industrial information with each other. We have forged a deep friendship. In the new era, this friendship is even more precious to us. Long live friendship!

\* \* \*

**Yeo Doo, Yun:** Chairman, Korea Agricultural Machinery Business Corporation (KAMBC)

First of all, I would like to extend my sincere congratulations to you at KAMBC on its 50<sup>th</sup> year anniversary

All of our people in Korea are thanked for contributing to the development of agricultural machinery industry both in Korea & Japan. We will long remember the great contribution of the AMA to the country's agricultural machinery development for the last 50 years.

It has been a wonderful and memorable association with you. So I wish all of you the very best life and tremendous success in everything you do in the future.

\* \* \*



**Suming Chen:** Co-editor, Taiwan; Professor, National Taiwan University; Director, Taiwan Agricultural Mechanization Research and Development Center

We extend the most sincere congratulations from Taiwan to President Yoshisuke Kishida and all members of "Agricultural Mechanization in Asia, Africa and Latin America (AMA)" Journal Publisher on the occasion of AMA 50<sup>th</sup> anniversary. Journal AMA has provided an important platform for the information exchanges and collaborations on the research and technology developments, not only in agricultural mechanization, but also in the engineering fields of agricultural, food, environment and energy in Asian, African and Latin American countries. Agricultural mechanization is very important to increase land productivity and to develop sustainable agriculture in order to meet the challenges of population increases and arable land scarcity. AMA has played a key role regarding agricultural mechanization in the past 50 years, and has made great and visible contributions.



To celebrate AMA 50<sup>th</sup> anniversary and appreciate its contributions in the past half a century, I would like to briefly describe the development of agricultural mechanization and share our experience in Taiwan. The first steam tractor was introduced to Taiwan for sugarcane farming in 1907, and first gasoline-powered tractors were imported in 1916; the agricultural mechanization in that period of time was aimed to sugarcane and pineapple farming. After Second World War, agricultural mechanization in Taiwan can be divided into six periods, they are:

**(1) Sprouting Period of Agricultural Machinery (1945-1960)**

Taiwan government made a policy to promote agricultural mechanization for major crops in 1953. Power tillers were commonly employed. Large demand of agricultural machinery caused the establishment of agricultural machinery manufacturing companies.

**(2) Growth Period of Agricultural Machinery (1961-1970)**

Because the migration of rural population to urban area due to industrial development, agricultural mechanization was more urgent; and the types of agricultural machinery in demand were also more diverse.

**(3) Period of Large-Scale Agricultural Machinery and Rice Farming Mechanization (1971-1978)**

Rice farming machinery tended to be large-scaled and specialized in operations such as land preparation, seedling cultivation, rice transplanting, harvesting and drying. The establishment of rice seedling centers and agricultural machinery “Custom Farming” centers were promoted.

**(4) Promotion Period of Comprehensive Agriculture Mechanization (1979-1991)**

An agricultural mechanization national fund was set up to promote comprehensive agriculture mechanization in 1979. Mechanization in land preparation, sowing, transplanting, cultivation, spraying, harvesting and drying was enhanced for crops including rice and upland crops such as corn, sorghum, soybean, peanuts, sweet potato and etc. Mechanization was also promoted for fruits, vegetables, flowers, livestock and fishery. Post-harvesting technologies were adopted for the managements and treatments for agro-products after harvesting such as pre-cooling for fruits, vegetables, and low temperature storage for rice grains. Emerging technologies such as spectral, optical, imaging, ultrasound methods were also introduced to enhance the development of mechanization.

**(5) Period of Agricultural Automation and Information (1992-2015)**

In this period, automation and information technologies were designed, implemented and applied to agricultural production, livestock production, fishery production, agricultural marketing services, and quarantine management. The functions of agricultural machinery and systems were further refined. “Non-destructive On-line Inspection System for Fruits” using NIR and imaging,

“Automatic Vacuum Plug Seeding System”, “Automation System for Pea Sprouts Production”, “Tube-grafting Robot for Fruit-bearing Vegetable Seedlings”, “Super-intensive Re-circulating Eel Culture System”, “Automatic Field Pest Monitoring System” using GSM module and “Computerized Auction Systems” for flowers, fruits, vegetables and swine were some of successful examples. Precision agriculture technologies were developed for both farm field and greenhouse. Plant factories were initiated and implemented for some vegetables and herbal medicines.

**(6) Period of Smart Agriculture (2016-now)**

Artificial intelligence (AI), information & communication technology (ICT), cloud computation, big data, Internet of Things (IoT), smart sensing, intelligent agricultural machinery and agricultural robots are new inputs for this period of smart agriculture. Promotion policies include: (a) improving the ability of stable produce supply by innovating the agricultural management with Smart Farmers Union; (b) building an application model integrating convenient and diversified agricultural digital services with value chains through ICTs; (c) creating a new communication model between growers and consumers through friendly interactive technologies. Smart production and digital service are the key strategies.

To sum up, founding 50 years is an important asset of AMA, and we would also like to extend our best wishes to AMA for the continuous success in the next 50 years.

\* \* \*



**Indra Mani:** Head, Division of Agricultural Engineering, ICAR-IARI, New Delhi; President, Indian Society of Agricultural Engineers

I am glad to know that AMA would like to publish, a special issue, entitled “SDG and agricultural mechanization in the world”, on its 50th anniversary. Mr.Yoshisuke Kishida publisher and chief editor of AMA deserves a big accolade on this occasion. Mr. Yoshisuke Kishida is a great visionary and highly experienced person who has deep understanding of changing scenario in world agriculture, in general, and mechanization in particular. A great job was started by his revered father with publication of AMA way back in 1971 which he continued with much greater zeal, passion and dedication.

Since, then 50 years have been passed and AMA has surpassed all heights of publication in terms of content, quality, and continuity. A glorious legacy of 50 years of AMA has witnessed number of landmarks in scientific publications. AMA’s efforts have helped developing best human resource and in dissemination of information on mechanization scenario in Asia, Africa and Latin America. I personally have a great bonding with Mr.Yoshisuke Kishida. I pray almighty to bless him very good health and he continues to serve the

cause of agriculture mechanization around the globe. Today civilization faces four most important challenges i.e., global food, energy and water insecurities, in addition to frightening effect of climate change.

AMA has been doing great effort to making people aware and helping professionals to equip themselves to face such challenges. I congratulate all those who are involved in bringing out this AMA 50<sup>th</sup> anniversary special issue. I, on the behalf of fraternity of Agricultural Engineering from India, as President of Indian Society of Agricultural Engineers compliment Mr. Yoshisuke Kishida for this great job. Entire team of AMA deserves a big applause.

\* \* \*



**C. R. Mehta:** Co-editor, India; Director, ICAR - Central Institute of Agricultural Engineering, Bhopal, India

I congratulate President Yoshisuke Kishida, Shin-norin Co. and his team at AMA for completing Golden Jubilee of AMA journal.

The journal has helped in disseminating recent development in the areas of farm mechanization particularly in developed countries of South Asia, Africa and Latin America to reduce drudgery of agricultural workers and enhancing production and productivity of field and horticultural crops. I again congratulate the untiring efforts made by you and your team at AMA to publish the journal on time with quality papers.

We wish all the best for the journal to continue to publish quality papers on time under your leadership.

We have written a paper entitled "Smart Farm Mechanization for Sustainable Indian Agriculture" for special issue of AMA. However, the publication of the issue has been postponed due to Covid-19 pandemic. I would appreciate if the paper is published in an earlier issue of AMA to create an awareness on efforts made in India for development of smart farm machinery for sustainable agriculture.

\* \* \*



Md. Rostom Ali

**Md. Rostom Ali:** Co-operating Editor and Professor, Bangladesh Agricultural University; **Shah M. Farouk:** Co-operating Editor and Retired Professor & Former Vice-Chancellor, Bangladesh Agricultural University, Bangladesh



S. M. Farouk

We wish to extend our deep appreciation to AMA for publishing a special issue on 50<sup>th</sup> anniversary with the title of SDGs and Agricultural Mechanization in the World. AMA is a wonderful platform where it's playing important role to make a bridge among experts around the world to work together for helping farmers in the developing

countries with appropriate agricultural mechanization. We hope AMA will continue the role to promote further sustainable agricultural mechanization for the advancement of agriculture in the developing countries like Bangladesh.

Bangladesh has successfully sustained its socio-economic developments over the past decades and earned relatively higher indices of growth compared to other developing countries. The agricultural production, especially cereals, fishes, poultry, etc. have grown manifold and basic food security has improved while the population has doubled to 160 million over a period of 50 years. Improved farming practices gradually adopted by the farmers include among many other items, use of machinery for land preparation, irrigation and some post harvest processes like threshing and grain drying. Continuation of the above mentioned success is facing some new challenges now as the experts are insisting that the productivity of agricultural land must be doubled by 2030 to sustain the overall development goals of the country. Handicaps affecting further improvement in farm mechanization as well as prospective areas of improvement include machinery more suited for the small farms, wastages of resources and farm produces, adoption of information technology for precision agriculture, improved management of production system and engaging better trained workforce in the farming activities for accelerating the improvement of farm mechanization. The government, as well as many institutions and non-government organizations are undertaking action plans for improving farm mechanization considered essential for maintaining the SDGs.

The government has taken an initiative to hand over 56,000 agricultural machineries to the farmers through a mega project worth Tk. 3,020 crore (30.2 Billion USD) which will be started in 2020. In the project, government will patronize the local machinery manufacturers for building capacity so that they will be more productive and self-dependent. This additional investment will definitely be enhanced to achieve SDGs. According to the farm mechanization policy 2019, farmers would be able to buy agricultural machinery with low price and able to get low cost or interest free loans with affordable conditions. Farmers and service providers will get an opportunity to purchase agricultural machinery in the haor area at 70% subsidy and 50% subsidy in other areas. In the mega project government has aimed to reduce post-harvest losses of crops, including the main crop rice, by up to 15%, save 50% time in cultivation time and cut costs by 20%.

Agricultural operations of major crops are not fully mechanized in the country but public and private organizations are working to improve the situation. There are several agricultural universities (BAU, Sylhet-AU, Sher-e-Bangla-AU, BSMRAU, HSTU, PSTU, KAU), public organizations (DAE, BRRI, BARI, BINA, BSRI, BMDA,

BJRI, RDA, BARD) and private enterprises (ACI Motors limited, The Metal (Pvt.) limited, Alim Industries limited, Mahbub Engineering workshop, Bangladesh Machine Tools Factory, Chittagong Builders & Machinery limited, iDE, CSISA-BD, CIMMYT, FAO, IFDC, PKSf, etc.) which are giving services in different ways to accelerate mechanization with the aim of resources conservation, reduction of losses and reduction of unit cost of production. All of the academicians and researchers are being suggested custom hiring service provision model, community based cultivation and precision agriculture in farming systems so that small-holders may get easy access to all kinds of agricultural machinery. Some farmers may also form a cooperative society for buying expensive farm machinery.

The present profile of agricultural mechanization in Bangladesh shows that 95% tillage, 95% irrigation, 1.5% harvesting, 95% paddy threshing, 0.5% planting and 90% pesticides applications are done by machines. Weeding application has also been mechanized at a satisfactory level. Progress of mechanized planting and harvesting has been slow due to unavailability of cost effective machines. Farmers face trouble in timely planting and harvesting of their crops due to the crisis of labor and high wages during the peak season. More than 90% production cost is mainly for manual labor based planting and harvesting of crops. Cost of production will be reduced significantly if farmers get transplanter and mechanical harvesters. Government has taken several initiatives to speed up mechanized planting and harvesting of crops. Government also encouraged the private sectors to focus on least mechanized areas like planting and harvesting machines. Recently, ACI Motors Ltd., The Metal (Pvt.) Ltd. and Alim Industries Ltd. are importing good quality and mechanically robust harvesting and transplanting machines suitable for local farming conditions.

Precision agriculture (PA) is a crop management strategy that uses information technology in collecting, processing, interpreting, decision making and implementing field or crop data to increase productivity and to reduce risks. Precision agriculture technologies can increase productivity by manifolds. If we want to successfully implement these technologies at farmer's level in Bangladesh we have to undertake systematic approaches. The very first and most important step should be emphasized on researches. The Department of Farm Power and Machinery (FPM) at Bangladesh Agricultural University (BAU) and other R & D organizations like DAE, BRRI, BARI, SPARRSO, etc. are playing a vital role in the research of precision agriculture technologies. They have emphasized various PA technologies like GPS, GIS, and others through various active projects. Different research organizations and universities may give more special focus to PA technologies as they hold great prospects. Although progress of agricultural mechanization in Bangladesh is slow but recent activities on agricultural mechanization is

considered satisfactory.

There is an excellent opportunity to involve rural youth into agriculture by investing in farm mechanization in alignment with smart technologies. It will create farming as a commercial and profitable sector in Bangladesh. Farm mechanization will be fully sustainable when it will be commercial and profitable. Therefore, facilitating the youth cohort's participation in agricultural machinery sector is also essential for sustainable use of farm machinery in the farming systems. In last five years, a group of academicians and researchers led by Professor Dr. Md. Monjurul Alam at BAU are giving field level training on agro-entrepreneurship development, operation and repair & maintenance of agricultural machinery with the involvement of women and youth under USAID funded appropriate scale mechanization innovation hub (ASMIH)-Bangladesh and post-harvest loss reduction innovation lab (PHLIL)-Bangladesh projects. All levels of stakeholders are trying to mechanize the farming activities more to reduce cost of operation and time of operation. Visible co-ordination and linkages among all stakeholders are required to accelerate farm mechanization for further contribution to GDP which will be helpful to attain SDGs in Bangladesh.

Everything changes with time and educational curriculum is no exception. To produce competent of agricultural engineers in the field of farm mechanization and smart farming systems, the Faculty of Agricultural Engineering and Technology at the Bangladesh Agricultural University, has updated and revised the curriculum and course contents for the degree of Bachelor of Science in Agricultural Engineering in 2020. Curricula of higher education systems in Bangladesh is monitored by institutional quality assurance cell (IQAC) formed by the university grants commission (UGC) and the Bangladesh accreditation council (BAC). We hope that the revised and updated curriculum based graduates will be more competent to contribute significantly in the field of farm mechanization with alignment of precision farming systems in Bangladesh.

Finally, we would like to take the opportunity to thank Mr. Yoshisuke Kishida, Publishers and Chief Editor of AMA, for this thoughtful initiative and publishing this special issue. We hope this special issue will pave the strong bond among the experts around the world in the spirit of "together we can" to achieve the SDGs and create a new era of agricultural mechanization to meet the needs of coming future.

\* \* \*



**Ali Mazin Abdul-Munaim:** Co-editor, IRAQ, PhD. Assistant Professor and Head, Dept. of Agricultural Machines and Equipment, College of Agricultural Engineering Sciences, University of Baghdad

Congratulations on the occasion of the 50<sup>th</sup> anniversary of the founding of the AMA.

On this beautiful occasion, I would like to share you my memories with the AMA when I was studying a master's degree in 1995, the AMA was my first reference to start my thesis. My supervisor for my Master's degree was Lutfy H. M.Ali, who was at that time, the co-editor for AMA in Iraq. I feel the time has taken me back 25 years, it is beautiful memories.

We wish more success in the near and far future for you and AMA.

\* \* \*



**Nguyen Hay:** Co-editor, Vietnam; Prof., President of Nong Lam Univ.

Agricultural Engineering is a very important field in enhancing the productivity and quality of agricultural products, building a strong economy for countries with high proportion of the population working in agriculture such as Vietnam, Asian nations, Latin America and others in the World.

Over 50 years ago, with great enthusiasm of some people who are now the key personnel of AMA Journal; they considered and decided to create the meaningful scientific journal not only in Japan but for all the nations struggling to find new technologies, modern equipment with the aim of agricultural development, happy and prosperous life.

With great efforts since 1971-1981, and call for the cooperation of scientists throughout the World to contribute to the development and growth of the AMA Journal; up to now, by 2020, AMA is 50 years old. And we look back on the significant contribution of the AMA Journal together.

As a Co-Editor of AMA since the 2000s, I got the journals regularly. And as the former Dean of the Faculty of Engineering and Technology, the former Vice President and then President of Nong Lam University (HCMC-Vietnam), the Vice President of Vietnamese Society of Agricultural Engineering, I consider the AMA Journal as an enormous and substantial resource, helping me convey good ideas to the students and researchers.

And from that key point, with AMA as a strong link, I look forward to the closer and more effective collaboration between researchers in the field of Agricultural Engineering globally. I do hope that we can implement appropriate measures to improve agricultural productivity in Vietnam and all over the World.

Especially in Vietnam, we are now facing agricultural production affected by climate change, sea level rise... Accordingly, we need a new model in co-ordination with the application of Mechatronics, Automation and AI to promote sustainable agriculture.

On the occasion of 50<sup>th</sup> Anniversary of the AMA Journal's establishment, I would like to wish AMA Journal all

the best, and I sincerely appreciate the huge contribution of AMA Journal to myself as well as my country.

\* \* \*



**G. Enkhbayar:** Co-editor, Mongol; Director, Mongolian University of Life Sciences

It was very nice heard about 50<sup>th</sup> anniversary of AMA.

I remember that I met and introduced with you at 10<sup>th</sup> international agricultural conference in 2009, in Thailand. Since we became good friends and I was given as editor of AMA, first time from Mongolia. Since that day, when we are accepting each issue of AMA and our colleague were been new chance to read and introduce with agricultural mechanization of world and many foreign countries.

I always happy for you. When you are very good scientist, good manager and very kindness person I met overseas people during ones.

I am sorry I couldn't work by editor as well as because my English skill is little.

AMA provided opportunity to contributors and readers in promoting farm machination.

Congratulations to management team of AMA for successful completion of fifty years.

\* \* \*



**Yakov Lobachevsky:** Co-editor, Russia; Deputy Director of VIM"

Please accept our heartfelt congratulations on the Golden anniversary of your AMA magazine.

During our visit to you in May 2018, we were pleased to get acquainted with the history of your magazine, which was founded by your father.

For many years your AMA magazine has been the best magazine in the world that provides in-depth analysis of agricultural mechanization in many continents.

\* \* \*



**Jan Pawlak:** Former Co-editor, Poland; ul. G. Bruna 34 m.44, 02-594 Warsaw

On the occasion of the 50<sup>th</sup> anniversary of the Shin-Norinsha Co. Ltd. please accept the appreciation of the outstanding achievements in promoting the development of agriculture, with particular emphasis on its mechanization. These achievements are reflected in the creation of a network of communication and exchange of experiences on a global scale, supporting scientific research projects, business consulting, market research, supporting scientific events stimulating the transfer of technology, impor-

tant especially for developing countries.

There are huge disproportions in the level of agriculture development and its mechanization on a world scale. This level is unsatisfactory in many developing countries. These are often countries with a food deficit. This situation poses a serious challenge to the world in the 21<sup>st</sup> century, and its solution is additionally hampered by the current coronavirus pandemic. It is necessary to implement progress in agriculture in developing countries taking into account the specificity of each of them. An important factor in the dissemination of technological progress understood in this way is the scientific journal AMA published by the the Shin-Norinsha Co. Ltd., which is a significant forum for the exchange of knowledge in the field of engineering, especially in agricultural mechanization. It is addressed primarily to developing countries, and the articles published in it take into account the specificity of these countries, promoting solutions appropriately adapted to the specific natural, economic and social conditions in these countries.

I would like to express my gratitude here for the opportunity to cooperate with this magazine. I remember this period with great pleasure, although I am aware that my participation in the cooperation was very modest.

Once again, congratulating the achievements so far, I wish you continued fruitful activity for the development of agriculture and its mechanization in the world, and all the best in work and personal life to the President and staff of the the Shin-Norinsha Co. Ltd.

\* \* \*



**Pavel Kic:** Co-editor, Czech Republic; Prof. Ing., DrSc. Czech University of Life Sciences, Prague

There is my pleasure to have this opportunity to express many thanks to the Company Shin-Norinsha Co., Ltd., and especially to the Chief Editor Mr. Yoshisuke Kishida, for fifty years of the excellent work in preparation and publication of the scientific journal AMA Agricultural mechanization in Asia, Africa and Latin America. This scientific journal has been a grate source of information for farmers, big support for machinery designers, workers and machinery producers, inspiration for students and very useful opportunity for exchange of information between the researchers, teachers and other specialist from all of the world, focused on problems of mechanization of agriculture and agricultural machinery.

The big progress in design, production and use of agricultural machinery which has been achieved during last fifty years resulted in enlarged quantity and improved quality of agricultural products and in better production of food in the world. Undoubtedly, the dissemination of information on new scientific and professional knowledge, new technical principles and new machines also

made a great contribution to the expansion of agricultural mechanization. AMA journal had a great influence and contribution to this positive development, especially in the countries of Asia, Africa and Latin America. That is why I wish a lot of success and new interesting articles from good authors to all members of the editorial team of AMA journal in the next years.

\* \* \*



**Milan Martinov:** Co-editor, Serbia; Faculty of Technical Sciences, Novi Sad

From the very beginning AMA, as only worldwide available R&D oriented journal, used to practice charitable work, to help underdeveloped and developing countries in the domain of agricultural engineering. And this, fifty years continuously. Congratulations, many thanks and best wishes for the future.

\* \* \*

**Nick Sigrimis:** Prof., PhDEE Cornell University, M.IEEE/CS,CSS,RAS/, IFAC, EurAgEng, ASABE, Geosmart-Geomations founder, Agricultural University of Athens [AUA]

Fifty years anniversary of efforts for the most Human's Sustainable Actions, such as food production, is a real victory. Mechanization, whether it is robotics harvesting for advanced fields or a simple potato harvester improve for underdeveloped, has an essential contribution to a resource sharing and GHG suffering world. So please accept my congratulations for your continued efforts and very definitely I would contribute at this stage in whatever sense you ask.

Best wishes to all co-editors

\* \* \*



**Vilas M. Salokhe:** Co-editor, India

Greetings from India! Hearty congratulations for AMA reaching another significant landmark in its long professional journey. This is possible due dedicated services by your beloved father and yourself.

Way back many years your beloved father laid the foundation for this esteemed journal especially well referred in developing parts of the world.

After taking over the baton from your father you further advanced the journal with full speed which has culminated in acquiring the pole position as one of the most sought journal in the Asian and African context. Hope AMA will continue to progress in the years to come.

\* \* \*



**Irenilza de Alencar Nääs:** Co-editor, Brazil; Former President, Brazilian Society of Agricultural Engineer (BSAE)

The Agricultural Mechanization in Asia, Africa and Latin America -AMA journal reaches a half-century of disseminating scientific information.

Such an accomplishment means a lot to researchers from developing countries. For a long time, the journal was practically the only one offering solutions to appropriate mechanization for small and medium-size farmers worldwide.

Not only pointing out answers but bringing up discussions on educational topics and other matters related to agricultural development.

Congratulations to all involved in pursuing the dream of reaching out the food production in all corners of the continents. You made the difference.

Let us wish for more success in AMA's future.

My special thanks to Yoshisuke Kishida for allowing me to be part of this outstanding achievement.

\* \* \*



**Hugo Cetrangolo:** Co-editor, Argentina; Prof. Buenos Aires' University

I want to congratulate you on the 50 years of AMA and share my happiness for this anniversary and my best wishes for you and the magazine in the future.

For more than 25 years I have been receiving AMA magazine, of which I have the honor of being co-editor, which fills me with pride.

Every time I receive a new copy, I am extremely happy, not only because of the technical information from leading researchers, but because I perceive that there is permanent improvement and that the magazine is a great help in improving agriculture in developing countries.

When I had the pleasure of visiting Mr. Kishida in Tokyo, I had the opportunity to see the facilities of the Editorial, where other publications of a very good level are produced in addition to AMA.

With all my heart I wish that this journey begun by Yoshisuke Kishida and his father will continue for many more years.

\* \* \*



**Edmundo Hetz:** Co-editor, Chile; Prof. University of Concepción

It is with great pleasure that I send you my most sincere, ample and profound congratulations to you, your editorial staff and working personnel on the Golden Anniversary of Agricultural Mechanization in Asia, Africa and Latin

America (AMA).

This very specialized Quarterly Magazine has become the most important means of bringing technology to a very large part of the world, especially in the developing countries. Emphasis has been placed in the use of meaningful mechanization and appropriate technology to develop an environmental and economically sustainable agriculture.

At the same time your Editorial Page has presented the agricultural world deeply felt and intelligent thoughts (reminders) about the urgent need to continue feeding an ever growing world population with less agricultural land and climate change among other problems (handicaps). These objectives can and should be achieved using appropriate technology and meaningful mechanization implementing an environmentally sustainable agriculture.

Moreover these very important ideas have been presented to AMA's readers for decades, initially, when very few persons gave any attention to them. I do hope AMA will continue to bring to the agricultural word in the next fifty years its very important message, for the good of all people. I wish AMA every success and fortune in the coming future.

\* \* \*



**K. C. Oni:** Co-editor, Nigeria; Univ. of Ilorin

I wish to congratulate Mr. Kishida and the hard working team of AMA on the occasion of the 50<sup>th</sup> Anniversary of AMA. This journal remains a veritable outlet for our research publications, particularly here in Nigeria and the West Africa sub-region. Valuable agricultural mechanization research information continue to be harnessed from around developing world, made possible by AMA. We in Nigeria are glad to identify with the goals and objectives of this journal. I there would like to contribute towards this 50<sup>th</sup> anniversary along the high-lighted topic.

Accept, Mr. Kishida, our unalloyed cooperation and our best wishes for a worthy celebration.

\* \* \*

**D. S. Balachandra Babu:** Chairman International Activities, Agricultural Machinery Manufacturers Association, AMMA India

I congratulate you and your team on 50<sup>th</sup> anniversary of journal AMA.

Over the past half century, you and AMA team and its partners have played a key role in advanced sustainable growth and improve economic opportunities around the world through quality publications. The AMA has enabled people involved in agriculture in developing countries to have UpToDate information on agricultural

machinery. Through these efforts Dr. Kishida has helped the Agricultural Engineering community to meet the Sustainable Food Security Goals. As we now accelerate our work to overcome the economic slowdown due to COVID 19, AMA will continue to be crucial in fostering inclusive economic growth and poverty eradication.

I appreciate the work you and your team do to advance the sustainability and promoting the present-day agricultural machinery for the benefit of farming community of developing countries.

Once again, I congratulate you and your team and wish you all success in times to come.

\* \* \*



**Koichi Hashiguchi**, Emeritus Professor of Kyushu University, Japan

The AMA was founded by Mr. Yoshisuke Kishida, President of Shin-Norinsha, Ltd. It is the only journal certified the Impact Factor (0.148) by ISI (Institute of Scientific Information) among a lot of journals published in the field of agricultural machinery, Japan. This fact means that AMA is highly appreciated in the field of agricultural machinery and contributing the development of agricultural machinery in the world, noting that the research papers in AMA is written by the researchers all over the world.

The founder and general editor: Mr. Yoshisuke Kishida is my friend over forty years, while he and I are same years old. We often discuss on the development of agricultural machinery and the other general topics, e.g. the social, the economical problems in the world. The discussions have been performed privately and in the many meetings in the agricultural machinery society, the committees in Science Council of Japan, etc. In addition, we have visited our homes each other often and visited often the night entertainment towns, drinking, dancing and singing Karaoke songs. In particular, we visited the night town "Nakasu" in my hometown Hakata several tens times. I believe firmly his high sociality, possessing the wide human connection all over the world. The connection is not limited to the male friends but extending to the female friends. For instance: He often calls for his female acquaintances when we have been drinking in midnights. They are quite pretty, beautiful or sexy. However, he is not a so-called playboy but the typical philanthropism. He phones to his wife often from night clubs to inform his present place and state, and further he shows the photographs of his daughter and grandchildren to waitress in night clubs. He has constructed the huge human network not only in Japan but also in the foreign countries as the mass medium-person and the executive member of Japanese Society of Agricultural Machinery, the American Societies of Agricultural Engineering, the Japanese

Society of Agricultural Information and the cooperative member of Science Council of Japan, etc.

I believe that AMA will continue to develop and contribute further to the agricultural mechanization towards the next fifty years. In addition, I hope to deepen our friendship further to enjoy our rest of life.

\* \* \*



**Yanoy Morejón Mesa**: Co-editor, Cuba; Prof. Agrarian University of Havana

AMA is a distinguished scientific Journal that allows developing countries to show their scientific results and favors links between teachers, researchers, technicians and specialists in agricultural machinery worldwide.

50 YEARS CULTIVATING AND PROMOTING A SCIENTIFIC-INNOVATIVE CULTURE.

\* \* \*



**Ganesh C. Bora**: Co-editor, USA; PhD, Associate Professor, Mississippi State University

Our heartiest congratulation on your 50 years of great service to Agricultural Mechanization in developing world.

It is a pleasure to serve through the journal. As we move on to Sustainable Development Goal through agriculture; mechanization is playing a major role in its new Avatar as 'Digital Agriculture'.

I am sure AMA will always be a change agent for prosperous agricultural development.

# Co-operating Editors



B Kayombo



M F Fonteh



S A Ndindeng



S E Abdallah



A A K El Behery



Ahmad Addo



R J Bani



I K Djokoto



A N GITAU



D K Some



K Houmy



A F Alonge



O A Oyelade



Umar B Bindir



J C Igbeka



E U Odigboh



K C Oni



U L Opara



N G Kuyembah



A H Abdoun

## -AFRICA-

### Benedict Kayombo

Assoc. Prof. of Soil and Water Eng., Dept. of Agric. Eng. and Land Planning, Botswana College of Agric., Univ. of Botswana, Private Bag 0027, Gaborone, BOTSWANA. TEL+267-3650125, bkayombo@bca.bw

### Mathias Fru Fonteh

Director, The College of Technology, The University of Bamenda, P.O. Box 811, Mankon Bamenda, Mezam Division, NW Region, CAMEROON. matfonteh@yahoo.com

### Sali Atanga Ndindeng

Dr., Rice Processing and Value-Addition Specialist, Africa Rice Center (AfricaRice), Sustainable Productivity Enhancement, M' bé Research Station, 01 B. P. 2551, Bouaké 01, COTE D'IVOIRE, S.Ndindeng@cgiar.org

### Said Elshahat Abdallah

Dr., Prof. of Agricultural Process Engineering Department of Agricultural Engineering, Faculty of Agriculture Kafrelsheikh University, Kafr Elsheikh 33516, EGYPT. TEL+20473148949, saidelshahat@agr.kfs.edu.eg; dr.selsahat@gmail.com

### Ahmed Abdel Khalek El Behery

Agric Eng. Research Institute, Agril. Research Center, Nadi El-Said St. P.O. Box 256, Dokki 12311, Giza, EGYPT. behery28@yahoo.com

### Ahmad Addo

Assoc. Prof., Department of Agril. Engg, Kwame Nkrumah Univ. of Sci. and Tech. (KNUST) Kumasi, GHANA. TEL+233-3220-60242, aaddo.coe@knust.edu.gh

### Richard Jinks Bani

Lecturer & Co-ordinator, Agric. Eng. Div., Faculty of Agric., Univ. of Ghana, Legon, GHANA

### Israel Kofi Djokoto

Prof., Israel Kofi Djokoto, Associate Prof. Univ. of Science and Technology, P.O.Box 420 ust, Kumasi, GHANA, profdjokoto@yahoo.com

### Ayub N. Gitau

Chairman and Associate Prof., Dept. of Environ-

mental and Biosystems Engineering, University of Nairobi, P.O Box 30197, Nairobi, KENYA, ayub.gitau@uonbi.ac.ke; gitauan@yahoo.co.uk

### David Kimutaiarap Some

Eng. Prof. Dept. of Agril & Biosystems Eng., School of Engg Chepkoilel University College of Moi Univ., P.O. Box: 2405-30100, Eldoret, KENYA, dkimutaisome2@gmail.com

### Karim Houmy

Dr., International Consultant on Agricultural Mechanization, 2 Rue Ali Al Haddani, Route Akrach, Souissi, Rabat, MOROCCO. TEL+212-7-680512, houmy@maghrebnet.net.ma

### Akindele Folarin Alonge

Ph.D, R. Eng, MNIM, Professor of Agricultural and Food Engineering/Consultant, Dept. of Agricultural & Food Engineering, Faculty of Engineering, University of Uyo, P. M. B 1017, Uyo, Akwa-Ibom State, 52003, NIGERIA. TEL+2348033603462, akindelealonge@uniuyo.edu.ng

### O. A. Oyelade

Dr., Farm Power and Machinery Dept., National Centre for Agril. Mechanization (NCAM), P.M.B. 1525, Ilorin, Kwara State, NIGERIA. TEL+2348069030588, yemibamigbedjoyalade@gmail.com

### Umar Buba Bindir

Secretary to the Adamawa State Government, The Government House, Yola, Adamawa State, NIGERIA. TEL+234-8-033-156-117, ubindir@yahoo.com

### Joseph Chukwugotium Igbeka

Prof., Dept. of Agril. Eng., Univ. of Ibadan., Ibadan, NIGERIA. TEL+234-2-810-1100-4, Library@ibadan.ac.ng

### Emmanuel Uche Odigboh

Prof., Agril. Engg Dept., Faculty of Eng., Univ. of Nigeria, Nsukka, Enugu state, NIGERIA. TEL+234-042-771676, MISUNN@aol.com

### Kayode C. Oni

Dept. of Agril. & Biosystems Eng., Faculty of Eng. & Technology, Univ. of Ilorin, PMB 1515, Ilorin, NIGERIA. TEL+234-803-5724708, kayoroll@gmail.com

### Umezuruike L. Opara

Research Prof., S. Africa Research Chair in Post-harvest Technology, Faculty of AgriSciences, Stellenbosch Univ., Private Bag X1, Stellenbosch 7602, SOUTH AFRICA. TEL+27-21-808-4604, opara@sun.ac.za

### Nathaniel Gbahama Kuyembah

Assoc. Prof., Njala Univ. Colle, Univ. of Sierra Leone, Private Mail Bag, Free Town, SIERRA LEONE. TEL+249-11-778620/780045

### Abdien Hassan Abdoun

Member of Board, Amin Enterprises Ltd., P.O. Box 1333, Khartoum, SUDAN. TEL+249-77860-780045

### Amir Bakheit Saeed

Assoc. Prof., Dept. of Agric. Eng., Faculty of Agric., Univ. of Khartoum, 310131 Shambat, SUDAN. TEL+249-11-310131, absaeed5@yahoo.com

### Abdisalam I. Khatibu

P. O. Box 2138, Zanzibar, TANZANIA. khatibu@zansec.com

### Solomon Tembo

52 Goodrington Drive, PO Mabelreign, Sunridge, Harare, ZIMBABWE.

## -AMERICAS-

### Hugo Alfredo Cetrangolo

Full Prof. and Director of Food and Agribusiness Program Agronomy College Buenos Aires Univ., Av. San Martin 4453, (1417) Capital Federal, ARGENTINA. TEL+54-11-4524-8041/93, cetrango@agro.uba.ar

### Irenilza de Alencar Nääs

Prof. Paulista University, São Paulo, Brazil: R. Dr. Bacelar, 1212 - Vila Clementino Cep: 04026-002, São Paulo - S.P., BRAZIL. irenilza@agr.unicamp.br

### Abdelkader E. Ghaly

Prof., Emeritus of Biological & Environmental Eng. Dalhousie Univ., P.O. Box 1500, 1360 Barrington St., Halifax, Nova Scotia, B3H 4R2, CANADA. Abdel.Ghaly@Dal.Ca

### Edmundo J. Hetz

Prof., Dept. of Agric. Eng. Univ. of Concepcion, Av.



A B Saeed



A I Khatibu



S Tembo



H A Cetrangolo



I de A Nääs



A E Ghaly



E J Hetz



M A L Roudergue



R Aguirre



O Ulloa-Torres





Y M Mesa



P P Rondon



S G C  
Magaña



H Ortiz-  
Laurel



A I Luna  
Maldonado



G C Bora



M R Goyal



A K  
Mahapatra



S M Farouk



Daulat  
Hussain



M A Mazed



R Ali



Chetem  
Wangchen



M A  
Basunia



Minzan Li



Xiwen Luo



S M Ilyas



Surya Nath



Indra Mani



C R Mehta

V. Mendez 595, P.O. Box 537, Chillan, CHILE. TEL+56-42-216333, ehetz@udec.cl

### Marco A. L. Roudergue

Mechanization and Energy Dept., Agril. Eng. Faculty, Campus Chillan, Univ. of Concepcion, Chile. Vicente Mendez #595, CHILE. TEL+56-42-2208709, malopez@udec.cl

### Roberto Aguirre

Assoc. Prof., National Univ. of Colombia, A.A. 237, Palmira, COLOMBIA. TEL+57-572-271-7000, ra@palmira.unal.edu.co

### Omar Ulloa-Torres

Prof., Escuela de Agricultura de la Region, Tropical Humeda(EARTH), Apdo. 4442- 1000, San Jose, COSTA RICA. TEL+506-255-2000, o-ulloa@ns.earth.ac.cr

### Yanoy Morejón Mesa

Agril. Engineer Univ. Agraria de La Habana, Facultad de Ciencias Técnicas, Autopista Nacional y Carretera de Tapaste Apartado, 18-19 San José de las Lajas, Mayabeque, CP 32700 CUBA. ymm@unah.edu.cu

### Pedro Paneque Rondon

Assoc. Prof., Universidad Agraria de La Habana, Facultad de Ciencias Técnicas, Autopista Nacional y Carretera de Tapaste, Apartado 18-19, San José de las Lajas, Mayabeque, CP 32700 CUBA. paneque@unah.edu.cu

### S. G. Campos Magaña

PhD. and Prof., Paseo de los Claveles #398, Colonia Parques de la Cañada. CP 25080, Saltillo, Coahuila, MEXICO. camposg\_1999@yahoo.com

### Hipolito Ortiz-Laurel

Head of Agric. Eng. and Mechanization Dept./ Postgraduate College, Iturbide 73, Salinas de Hgo, S.L.P., C.P. 78600, MEXICO. TEL+52-496-30448

### Alejandro Isabel Luna Maldonado

Prof. and Head of the Dept. of Agricultural and Food Engineering, Autonomous University of Nuevo Leon, Nuevo León, MEXICO. alejandro.lunaml@uanl.edu.mx; alejun@yahoo.com

### Ganesh C. Bora

Associate Prof., Dept. of Agricultural and Biological Engineering, Mississippi State Univ., 130 Creelman St., Room 242, P.O. Box 9632, MS 39762, U.S.A. gcbora@abe.msstate.edu

### Megh R. Goyal

Senior Acquisitions Editor, Agric. & Biomedical Eng. and Retired Professor in Agric. & Biomedical Eng. Univ. of Puerto Rico, Mayaguez P.O. BOX 86, Rincon, PR-00677, U.S.A. goyalmegh@gmail.com

### Ajit K. Mahapatra

Agric. & Biosystems Eng. Dept., South Dakota State Univ., P.O. Box 2120 Brookings, SD 57007-1496, U.S.A. TEL+1-605-688-5291, mahapata@sdsstate.edu

## -ASIA and OCEANIA-

### Shah M. Farouk

Prof. (Retd.), Farm Power & Machinery Dept., Bangladesh Agril. Univ., Mymensingh 2202, BANGLADESH. TEL+880-1711-801923, smf1941@yahoo.com

### Daulat Hussain

Dean, Faculty of Agric. Eng. and Technology, Bangladesh Agril. Univ., Mymensingh-2202, BANGLADESH. TEL+880-91-52245

### Mohammed A. Mazed

Member-Director, Bangladesh Agri. Res. Council, Farmgate, Dhaka, BANGLADESH. mamazed@barcbgd.org

### Rostom Ali

Prof., Dept. of Farm Power and Machinery, Bangladesh Agricultural University, Mymensingh-2202, BANGLADESH. rostomfpm@bau.edu.bd

### Chetem Wangchen

Programme Director Agril. Machinery Centre Ministry of Agric. Royal Government of Bhutan, Bondey Paro Bhutan 1228, BHUTAN. krtamc@drunknet.bt

### Mohammad Ali Basunia

Associate Prof., Mechanical Engineering Programme, Institute Teknologi Brunei (ITB), Jalan Tungku Link, Gadong BE 1410, BRUNEI DARUS-SALAM. ali.basunia@itb.edu.bn

### Minzan Li

Prof. of College of Information and Electrical Engineering, China Agricultural University, P.O. Box 125, China Agricultural University (East Campus), Qinghua Donglu 17, Haidian District, Beijing, 100083, CHINA. limz@cau.edu.cn

### Xiwen Luo

Prof. of South China Agricultural University; Aca-

demician of Chinese Academy of Engineering, Wushan, Guangzhou, 510642, CHINA. xwluo@scau.edu.cn

### S. M. Ilyas

Prof. Green View Apartment, Flat-699; Pocket-2; Sector-19; Dwarka, NEW DELHI-110 075, INDIA. Tel+91-95608 48971, smilyas15@gmail.com

### Surya Nath

Flat #1143, G Block, Galaxy North Avenue, GC-3, Gaur City, Greater Noida. UP. 201009, INDIA. TEL +234-042-771676, surya.nath@rku.ac.in

### Indra Mani

Prof., Head of Division of Agril. Eng. IARI, New Delhi-110012, INDIA. maniindra99@gmail.com

### C. R. Mehta

Project Coordinator, AICRP on Farm Implements and Machinery, ICAR - Central Institute of Agricultural Engineering, Nabi-bagh, Berasia Road, Bhopal -462 038, INDIA. crmehta65@yahoo.co.in

### A. M. Michael

1/64, Vattekkunnam, Methanam Road, Edappally North P.O., Cochin, 682024, Kerala State, INDIA. kmichael65@eth.net

### B. S. Pathak

Adjunct Prof., Indian Agril. Research Institute, KC5, Kavi Nagar, Ghaziabad- 201002, INDIA. bspathakprof@gmail.com

### Vilas M. Salokhe

Prof., Flat B-1, Royal Gateway Apartment Near Yal-lama Temple, Main Road Kasaba Bawada Kolhapur -416006, INDIA. vsalokhe@yahoo.com

### Gajendra Singh

Adjunct Professor, Indian Agricultural Research Institute (IARI), 86-C, Millennium Apartments, Sector-61, NOIDA, U. P. 201301, INDIA. TEL+91-99-71087591, prof.gsingh@gmail.com

### Sitaram Dagdupant Kulkarni

Dr., Flat No. 105, Guruprasad Apptts., Plot No. 85 & 86, Survey No. 78, Left Bhusari Colony, Kothrud, Pune - 411038, INDIA. sdkulkarnispu@gmail.com

### S. R. Verma

Ex-Dean & Prof. of Agr. Eng., H. No. 14, Good Friends Colony, Barewal Road, Ludhiana 141012. Punjab, INDIA. TEL+91-161-2551096, srverma10@yahoo.com



A M  
Michael



B S Pathak



V M  
Salokhe



G Singh



S R Verma



P Soni



Kamaruddin  
Abdullah



M  
Behrooz-Lar



Saeid  
Minaei



A  
Mahdavian



A M Abdul-Munaim



H Hasegawa



B A Snobar



J H Chung



In-Bok Lee



M Z Bardaie



Enkhbayar Gonchigdorj



M P Pariyar



H P W Jayasuriya



Alamgir A Khan



A Q A Mughal



M S Mirjat



N A Abu-Khalaf



R M Lantin



R P Venturina



S A Al-Suhaibani



A M S Al-Amri



S G Illangantileke



Suming Chen



S Krishnasreni

### Peeyush Soni

Associate Prof., Dept. of Agricultural and Food Engineering, Indian Institute of Technology Kharagpur, Kharagpur, West Bengal -721302, INDIA. TEL+91-3222-283100, soni@iitkgp.ac.in

### Kamaruddin Abdullah

The Graduate School/Renewable Energy, Darma Persada University, Jl. Radin Inten II, Pondok Kelapa, East Jakarta, 13450, INDONESIA. TEL+64-21-8649051, kabdullah0997@yahoo.com

### Mansoor Behroozi-Lar

Prof., Emeritus Tehran Uni. Agr. Eng., Ph. D., Jalal All Ahmad Nasim St. Nasim Danesh Complex Block #35, second floor Tehran, IRAN. Behroozil@yahoo.com

### Saeid Minaei

Assoc. Prof., Dept. of Agr. Machinery Eng., Tarbiat Modares Univ., P.O.Box 14115-336, Tehran, IRAN. TEL+9821-44180537, minaee@modares.ac.ir

### Alireza Mahdavian

Assistance Prof., Department of Biosystems Engineering, Tarbiat Modares Univ., P.O.Box 14115-336, Tehran -14977-13111, IRAN. TEL +98-912-3346506, al.mahdavian@gmail.com; a.mahdavian@modares.ac.ir

### Ali Mazin Abdul-Munaim

Assistant Prof., Dept. of Agril. Machines and Equipments, College of Agric., Univ. of Baghdad, IRAQ. TEL+964-778-4561, old2a3y@yahoo.com

### Hideo Hasegawa

Assoc. Prof., Institute of Science and Technology, Niigata University, 8050 Ikarashi 2-no-cho, Nishi-ku, Niigata 950-2181 JAPAN. +81-25-262-6690, hsgw@agr.niigata-u.ac.jp

### Bassam A. Snobar

Prof., Univ. of Jordan, Faculty of Agriculture, Amman 11492, JORDAN. snobar@ju.edu.jo

### Jong Hoon Chung

Prof., Dept. of Biosystems & Biomaterials Science and Eng., College of Agril. and Life Sciences, Seoul National Univ., Bldg 200 Rm 2216 1 Gwanangno, Gwanak-Gu, Seoul, 151-742, KOREA. TEL+82-2-880-4601, jchung@snu.ac.kr

### In-Bok Lee

Prof., Laboratory of Aero-Environmental & Energy Engineering (A3EL), Dept. of Rural Systems Eng., College of Agril. & Life Sciences, Seoul National

Univ., San 56-1, Shillim-dong, Gwanak-gu, Seoul-city, KOREA. TEL+82-2-880-4586, iblee@snu.ac.kr

### Muhamad Zohadie Bardaie

Prof., Dept. of Agril. and Biosystems Eng., Univ. Putra Malaysia, 43400 upm, Serdang, Selangor, MALAYSIA. TEL+60-3-8946-6410

### Enkhbayar Gonchigdorj

Director, School of Eng. & Technology, Mongolian University of Life Sciences, Ulaanbaatar, Zaisan, 17024, MONGOLIA. TEL+60-976-11-341554 enkhbayar@mul.s.edu.mn

### Madan P. Pariyar

Consultant, Rural Development through Selfhelp Promotion Lamjung Project, German Technical Cooperation. P.O. Box 1457, Kathmandu, NEPAL.

### Hemanatha P. W. Jayasuriya

College of Agril. and Marine Sciences, P.O. Box 34, PC 123Al-khod, Muscat Sultanate, OMAN. TEL+968-2414-1223, hemjay@squ.edu.om

### Alamgir A. Khan

Research Engineer, Agricultural Mechanization Research Institute, Multan, PAKISTAN. alamgirakhtar@hotmail.com

### A. Q. A. Mughal

Research Professor, Greenwich Univ., DK-10, Street 38t, Darakshan, DHA Phase-6, Karachi-75500, PAKISTAN. dr.aqmughal@greenwich.edu.pk

### Muhammad Saffar Mirjat

Dean, Faculty of Agril. Eng., Sindh Agriculture Univ. Tandojam, PAKISTAN. TEL+92-221653160, drmirjat@hotmail.com

### Nawaf A. Abu-Khalaf

Assistant Prof., Palestine Technical Univ. -Kadoorie (PTUK), P.O.Box 405, Hebron, West Bank, PALESTINE. TEL+972-2-2227-8467, nawafu@hotmail.com

### Reynaldo M. Lantin

Retired Professor, College of Engineering and Agro-Industrial Technology, University of the Philippines Los Banos, College, Laguna 4031, PHILIPPINES. TEL+63-49-536-2792, reylantin@gmail.com

### Ricardo P. Venturina

PHILIPPINES.

### Saleh Abdulrahman Al-suhaibani

Prof., Agril. Eng. Dept., College of Agric., King Saud Univ., P.O. Box 2460 Riyadh 11451, SAUDI ARABIA.

salsuhaibani@gmail.com

### Ali Mufarreh Saleh Al-Amri

Prof., Dept. of Agril. Systems Eng., College of Agril. Sciences & Food, King Faisal Univ., P.O.Box 55035, Al-Ahsa, 31982 SAUDI ARABIA. aamri@kfu.edu.sa

### Sarath G. Illangantileke

Prof., Sarath Illangantileke, Consultant in Agric Engineering, Mechanization and Education, 4/567 Victoria Range Bungalows, Kengalla, SRI LANKA. sageilan@gmail.com

### Suming Chen

Prof., Dept. of Bio-Industrial Mechatronics Eng., National Taiwan Univ., 1, Section 4, Roosevelt Road, Taipei, TAIWAN. TEL+886-2-33665350, schen@ntu.edu.tw

### Suraweth Krishnasreni

Emeritus Prof. 24/77 Baan Kasemsan 1, Soi Kasemsan 1 Rama 1 Rd., Wangmai, Pathumwan, Bangkok 10330, THAILAND, surawethk@gmail.com

### Surin Phongsupasamit

President, Institute for Promotion of Teaching Science and Technology, 924 Sukumit Rd. Klomg Toey Bangkok, THAILAND, surin1950@hotmail.com

### Akkapol Senanarong

Agricultural Engineering Research Institute Department of Agriculture, 50 Phaholyothin Rd., Jatuchak Bangkok 10900, THAILAND, akkapol@ksc.th.com

### Can Ertekin

Prof., Dpt. of Farm Machinery and Technologies Eng., Faculty of Agril., Akdeniz University, 07070, Antalya, TURKEY. ertekin@akdeniz.edu.tr

### Imad Haffar

Managing Director, Palm Water Jumeirah Village (Site Office Gate #10) Al Khail Road, P.O. Box 215122, Dubai, U.A.E. Tel+971-4-375-1196, imad.haffar@palmwater.ae

### Nguyen Hay

Prof., President of Nong Lam Univ., Linh Trung Ward, Thu Duc District, Ho Chi Minh City, VIET NAM. nguyenhay@gmail.com

### Pham Van Lang

VIET NAM. langvcd@yahoo.com



S Phongsupasamit



A Senanarong



C Ertekin



I Haffar



N Hay



P V Lang



T H Katardjiev



P Kic



J Müller



K P Ferentinos



Nick Sigrimis



E Gasparetto



Y Lobachevsky



M Martinov



J Ortiz-Cañavate



Brian G Sims

### -EUROPE-

#### Tihomir Hristov Katardjiev

General Manager at Yogurtson Trade Ltd., Omachi 216-74, Ichikawa-shi, Chiba-ken 272-0801, Japan (BULGARIA). miro@yogurtson.com

#### Pavel Kic

Professor, Czech Univ. of Life Sciences Prague, Faculty of Eng. 16521 Prague 6-Suchdol, CZECH REPUBLIC. TEL+420-2-2438314 kic@tf.czu.cz

#### Joachim Müller

Prof. of the Univ. Hohenheim, Institute of Agril. Eng., Head of Agric. Eng. in the Tropics and Sub-tropics, Univ. of Hohenheim, 70593 Stuttgart, GERMANY. TEL+49-711-459-22490, Joachim.mueller@uni-hohenheim.de

#### Konstantinos P. Ferentinos

Researcher, Dept. of Agricultural Engineering,

Institute of Soil & Water Resources, Hellenic Agricultural Organization "Demeter", Ministry of Agriculture and Food of Greece, 61 Dimokratias Av., Athens 13561, GREECE. kpf3@cornell.edu

#### Nick Sigrimis

Prof., Agricultural University of Athens, Iera Odos 75, Athina 118 55, GREECE. TEL +30-6940940885, ns@aua.gr

#### Ettore Gasparetto

Via Galilei Galilei 17, I-35121 Padova, ITALY. TEL +39-0250316619, ettore.gasparetto@unimi.it

#### Yakov Lobachevsky

Deputy Director of VIM, Federal State Budgetary Science Institution "Federal State Agro Engineering Center VIM", 1st Institutskiy passage, 5., Moscow -109428, RUSSIA. lobachevsky@yandex.ru

#### Milan Martinov

Prof., Faculty of Technical Sciences, Chair for Biosystems Eng., Novi Sad, SERBIA. TEL+ 381-21-485-2369, MilanMartinov@uns.ac.rs

#### Jaime Ortiz-Cañavate Puig-Mauri

Dpto. Ingeniería Rural Universidad Politécnica de Madrid, Esc. T. S. Ing. Agrónomos 28040-Madrid SPAIN. TEL+34-91-336-5852, jaime.ortizcanavate@upm.es

#### Brian G. Sims

FAO Agricultural Mechanization Consultant. 3 Bournside Bedford MK41 7EG, U.K. sims.brian2@gmail.com

### Retirement Co-editors' Name List

Co-editor's name	Nationality	Inaugural year	Retired year	Co-editor's name	Nationality	Inaugural year	Retired year
Adrian Moens	Netherlands	1972	1989	Armed Hossain Mirdha	Mexico	1982	1991
Bala Krishna Shrestha	Nepal	1972	1991	A. A. Valenzuela	Chile	1982	2013
Chul Choo Lee	Korea	1972	2014	David Boakye Ampratwum	Ghana	1982	2011
Chau Van Khe	Vietnam	1972	1980	Kshirode Chandra Roy	Bangladesh	1982	1985
Manbahadur Gurung	Bhutan	1972	2006	M. H. Abdel Aziz	Saudi Arabia	1982	1991
Merle L. Esmay	U. S. A.	1972	1990	Krishna Prakash Srivastava	Ethiopia	1983	1989
Giuseppe Pellizzi	Italy	1973	2012	Muhammad Siddique Chaudhry	U. S. A.	1983	1991
Mohamed A. Bedri	Sudan	1973	1987	Wimala Tissa Weerakoon	Zambia	1983	1985
Shahansha-Uddin Choudhury	Bangladesh	1973	1991	Harry D. Henderson	Lebanon	1984	1985
T. B. Muckle	U. K.	1973	1978	Mohammad Afzal	Pakistan	1984	1994
Chang Joo Chung	Korea	1975	2014	A. P. Kaloyanov	Bulgaria	1985	2013
T. Tougaard Pedersen	Denmark	1975	1990	Soedjatmiko	Indonesia	1986	2014
Bilash Kanti Bala	Bangladesh	1976	1982	Aalbert Anne Wanders	Netherlands	1988	2007
George B. Hanna	Egypt	1976	1988	Ali Mahmoud El Hossary	Egypt	1988	2010
Jun Sakai	Japan	1976	2015	Chanchai Rojanasaroj	Thailand	1988	2011
Siswadi Soepardjo	Indonesia	1976	1985	Edward A. Baryeh	Zimbabwe	1988	2014
Tieng-Song Peng Taiwan	Taiwan	1976	2015	T. P. Ojha	India	1988	2015
Mohammad Ilyas	Pakistan	1977	1981	Eltag S. Eldin Mahmoud	Sudan	1990	2011
Amala Prasad Sharma	Fiji	1978	1981	Henrik Have	Denmark	1990	2009
Arumugam Kandiah	Ethiopia	1978	1989	Graeme Ross Quick	Australia	1995	2015
Bherulal T. Devrajani	Pakistan	1978	2004	Rafiq ur Rehman	Pakistan	1995	2015
John Kilgour	U.K.	1978	2014	Abdulsamad Abdulmalik Hazza'a	Yemen	1999	2014
Satish Chandra	Fiji	1979	1990	Yunus Pinar	Turkey	1983	2016
Jitendra P. Mittal	Nigeria	1980	1993	William J. Chancellor	U.S.A.	1972	2017
Naresh Chandra Saxena	India	1980	1988	Kunihiro Tokida	Japan	2016	2017
Paris Andereou	Lebanon	1980	1984	Shujun Li	China	2012	2018
Wang Wanjun	China	1981	2012	S. F. (Sen-Fuh) Chang	Taiwan	1987	2018
Allah Ditta Chaudhry	Pakistan	1981	2015	Jan Pawlak	Poland	2002	2019
Allan L. Phillips	U. S. A.	1981	2004	Oleg S. Marchenko	Russia	2003	2019
Julien G. Van Lancker	Brundi	1981	1989	W. B. Hoogmoed	Netherlands	2007	2019
Suppiah Kathirkamathamby	Sri Lanka	1981	1991	Sitaram Dagdupant Kulkarni	India	2017	2020

◆ ◆ ◆  
**Vol.49, No.4, Autumn 2018**

Agricultural Mechanization in Morocco: Historical, Present Situation and Future Prospects (E. H. Bourarach, O. El Gharras) 7

Current Status of Agricultural Mechanization in East Africa (S. Nishino, M. Shigehara, G. Takahata) ..... 13

Trends in Agricultural Mechanization in Kenya's Maize Production Areas from 1992-2012 (H. D. Groote, C. Marangu, Z. M. Gitonga) ..... 20

The Current Situation and Perspectives Regarding Agricultural Mechanization in the Republic of Mozambique (M. Q. C. Monjane, A. J. P. Graça, H. Hasegawa) ..... 33

A General Overview on Agricultural Mechanization in Zimbabwe (T. A. Thebe) ..... 38

Break-Even Analysis for Hiring Decision of Agricultural Mechanization Services in Iraq (Z. R. Kadhim, N. B. Man, I. A. Latif, K. W. K. Seng) ..... 44

Effective Purification of Concentrated Organic Wastewater from Agro-Industrial Enterprises, Problems and Methods of Solution (A. V. Artamonov, A. Yu. Izmailov, Yu. A. Kozhevnikov, Yu. Yu. Kostyakova, Ya. P. Lobachevsky, S. V. Pashkin, O. S. Marchenko) ..... 49

Development and Evaluation of Self-propelled Puddler for Sandy-Loam Soils of West Bengal in India (A. Khadatkar, E. V. Thomas) ...54

Seedling Beet Application in Sugar Beet Agriculture (K. M. Tugrul) ..... 61

The Effects of PTO Options on Operational Characteristics of Disc Fertilizer Spreader (S. K. Sümer, H. Kocabiyik, G. Çiçek) ..... 68

Investigation of Grain Distribution Characteristics in an Axial Flow Thresher Using Impact Sensors (S. Kumar, D. Singh, B. Dogra, R. Dogra) ..... 75

Transducers for Measurement of Draft and Torque of Tractor-Implement System—A Review (C. R. Chethan, V. K. Tewari, B. Nare, S. P. Kumar)..... 81

◆ ◆ ◆  
**Vol.50, No.1, Winter 2019**

An Assessment of Conventional and Conservation Tillage Systems in Terms of Carbon Dioxide Emissions in Corn Production (H. Huseyin Ozturk) ..... 7

Development of a Slider Crank Squeezing Action Sugarcane Juice Extractor (J. O. Olaoye, O. A. Oyelade) ..... 19

Development and Evaluation of Semi-Automatic Six Row Onion Seedlings Transplanter (A. Pandirwar, A. Kumar, J. K. Singh, I. Mani, A. Bhowmik) ..... 29

Status of Rice Transplanters in India (U. Kumar, E. V. Thomas)..... 36

Development and Evaluation of Low Pressure Multi Briquetting Machine (A. A. Kumar, R. Jhansi, U. H. Vardhan, S. M. Gousia, A. K. Kumar) ..... 48

A Laboratory Study of the Pneumatic Sowing Device for Dotted and Combined Crops (A. B. Khutaevich)..... 57

Performance Evaluation of an Axial-flow Pearl Millet Thresher (A. Afolabi, D. D. Yusuf, U. S. Muhammed)..... 60

Design and Development of Combined Conservation Tillage Machine with Chiselers and Clod Pulverizing Roller (K. Murmu, T. C. Thakur)..... 66

Optimum Design of a Chisel Plow for Grain Production in the Republic of Buryatia, Russian Federation (T. Sandakov, H. Hasegawa, N. Sandakova, L. Chang, D. Radnaev)..... 73

Simulation of Monkey and Human Climbing Up the Palm Tree (M. Behrooz Lar) ..... 79

Indian Agriculture Counting on Farm Mechanization (C. R. Mehta, N. S. Chandel, P. C. Jena, A. Jha)..... 84

Prospective Technologies, Types and Calculation of the Technical Means for the Production of Forages in Arid Regions of the Country (O. Marchenko, A. Tekushev)..... 90

◆ ◆ ◆  
**Vol.50, No.2, Spring 2019**

Current Situation of Agricultural Mechanization and Conservation Agriculture in Latin America (P. P. Rondón, Y. M. Mesa, H. C. Fernandes, M. V. G. Águila, A. M. Caballero)..... 13

Current Status and Future Prospect of the Agricultural Mechanization in Brazil (E. C. Mantovani, P. E. B. de Oliveira, D. M. de Queiroz, A. L. T. Fernandes, P. E. Cruvinel) 20

The Valorization of Embedded Technology in the Sprayers to Obtain Operating Gains and Pulverization Quality (Marcella Guerrero de Jesus) ..... 29

Situation of Agricultural Mechanization in Argentina - A Perspective (H. A. Cetrangolo).. 33

Present Status and Future Prospects of Agricultural Mechanization in Mexico (H. Ortiz-Laurel, D. Rosas-Calleja, H. Debernardi de la Vequia)..... 40

Current Situation of Agricultural Mechanization in Mexico (E. R. Carbajal, G. H. Cuello, O. G. Mejía) ..... 46

Mechanization of Irrigation in Latin America (G. H. Cuello, E. R. Carbajal, J. P. Petitón)· 52

Ecuador: Current Mechanization Status and Issues That Rice Producers Facing Now (A. Utsunomiya) ..... 57

Agricultural Mechanization in Ecuador (L. Shkiliova, C. E. I. Coronel, R. X. C. Mera) 72

Mechanization of Cassava Cultivation (Manihot Esculenta L., Cranz) in Venezuela in View of Its Physical-Mechanical Properties (A. G. Pereira, E. P. Motta, A. H. Gómez, J. G. Coronado, M. L. Acosta)..... 78

Abrasive Wear Assessment under Laboratory Conditions in Disks of Tiers Used in Venezuela (A. H. Góez, I. J. M. Ortiz, A. G. Pereira, J. G. Coronado)..... 83

Future Trends in the Chilean Agricultural

Machinery Industry (M. A. López, C. Correa, E. J. Hetz)..... 88

Present Status and Prospects of Agricultural Mechanization in Cuba (Y. M. Mesa, P. P. Rondón, L. J. S. Diaz) ..... 94

◆ ◆ ◆  
**Vol.50, No.3, Spring 2019**

Effect of Rotary Plough and Precision Land Levelling on Faba Bean Response to Organic Fertilization (O. T. Bahnas, M. Y. Bondok)·· 7

Physico-Mechanical Properties of Cassava Stem as Related to Cutting (Sahapat Chalachai, Peeyush Soni) ..... 14

Development of a Watermelon (*Citrullus lanatus*) Seed Extractor (Shrinivas Deshpande, G. Senthil Kumaran, A. Carolin Rathinakumari)..... 23

Predicting Wheat Harvest Time Using Satellite Images and Regression Models (Sepideh Taghizade, Hossain Navid, Yasser Maghsod, Mohammad, Moghadam Vahed, Reza Fellegarii)..... 28

Design, Development, and Evaluation of a Fuzzy-based Automatic Guidance System for JD955 Combine Harvester (Alireza Mahdavian, Saied Minaei, Ahmad Banakar) ..... 34

Seed Drill Discharge Rate Variation Due to Varietal Differences Using an Automated Calibration Test Rig (Daanvir Karan Dhir, Pradeep Rajan, S. R. Verma) ..... 43

Optimization of Combine Crop Parameters for Paddy Harvesting by Head Feed Combine (Ingole Omprakash Avdhut, Anil Kumar, Vijaya Rani, S. Mukesh, Nitin Kadwasra, Kanishk Verma)..... 48

Development of a Chopping Apparatus for Cactus Prickly Cladodes (H. M. Duran-García, U. Marquez-Perez, E. J. Gonzalez-Galvan, E. D. Rössel-Kipping, H. Ortiz-Laurel) ..... 58

Modification of Rotary Power Tiller units for Biasi (Interculture Operation) Rice Cultivation in Eastern India (Ajay Kumar Verma, Samir Santiya)..... 62

Design and Experiment of Associated Baler for Combine Harvester (Li Baoqian, Wu Gaofeng, Liu Yunpeng, Lv Fengzhao, Shi Dongsheng)..... 69

The Role of Agricultural Mechanization in the Process of Modernization of Agriculture in Vietnam - Contribution of Agricultural Engineering to Production After Years of Conducting Renovation (Pham Van Lang, Nguyen Hay, Do Thi Tam, Nguyen Tien Han) ..... 79

◆ ◆ ◆  
**Vol.50, No.4, Autumn 2019**

Development of an Efficient Fruit Cum Vegetable Grader for Spherical Commodities (S. Mangaraj, R. K. Pajnoo) ..... 7

Design and Experiment of a Fertilizer Deep Applicator for Twin-row within One Ridge (Wu XueMei, Guy Fipps, Fugui Zhang, Xu Li, DeLong Fu) ..... 13

Current Situation and Perspectives of Educa-

tion for Agricultural Mechanization in the Republic of Buryatia of the Russian Federation (Mikhail Dorzhiev, Hideo Hasegawa, Tsyden Sandakov, Nadezhda Sandakova, Konstantin Luzbaev).....	20
Design and Development of Thresher for Onion Umbels ( <i>Allium Cepa Variety Aggregatum L.</i> ) (M. M. Pragalyaashree, R. Kailaapan, Z. John Kennedy).....	25
Influence of Surface Hardening with Carbon Nanotubes- Hard Chrome Composite on Wear Characteristics of a Simple Tillage Tools (A. M. Zein El-Din, Saad F. Ahmed, M. A. Khattab, R. G. Abdel Hamied).....	32
Research on a Method to Measure and Calculate Tillage Resistance of Tractor Mounted Plough (Han Jiangyi, Lin Cunhao).....	38
Automatic Seed Cum Fertilizer Drill: Modification and Performance Evaluation for Intercropping (Ajay Kumar Verma, Mukesh Kumar Pandey).....	44
Manufacturing and Testing the Performance of Prototype for Grading of Dates (Said Elshahat Abdallah, H. M. Sorour, A. M. Deris, Awad Ali Tayoush).....	49
Impact of Slice Size on Kinetic Behavior and Drying Time of Fresh-Cut Apple ( <i>Malus domestica</i> ) (Destiani Supeno, Pandu Sandi Pratama, Won-Sik Choi).....	61
Designing and Testing an Innovative Soybean Seed Grader with Oval-hole Screen Type (I. K. Tastra, Uning Budiharti, N. R. Patriyatyaty).....	65
Yield and Economics Attributed Study of Direct Seeding and Transplanting Method on Beds for Onion ( <i>Allium Cepa L.</i> ) Crop with Pneumatic Precision Multicrop Planter and Manual Transplanting Method Along With Rotary Tiller Cum Bed Former in Indian Conditions (Surinder Singh Thakur, Manjeet Singh, Rupinder Chandel).....	76

◆ ◆ ◆  
**Vol.51, No.1, Winter 2020**

Evaluation Parameters Affecting the Performance of Vibrating Vertical Tillage Equipment – First Stage (Guillen Sánchez Juan, Santos G. Campos Magaña, Carlos Sánchez López, Oscar M. González-Brambila, Gabriela Ramírez-Fuentes).....	7
Design, Fabrication and Evaluation of a Power Operated Walnut Grader (Syed Zaameer Hussain, Umbreen Showkat, Sheikh Idrees, Monica Reshi).....	14
Single Locking Cotton Feeder for Enhancing Ginning Efficiency of Double Roller Gin (V. G. Arude, S. P. Deshmukh, P. G. Patil, S. K. Shukla).....	24
Development and Testing of a Coconut Dehusking Machine (P. M. Chukwu, B. A. Adewumi, I. A. Ola, O. D. Akinyemi).....	29
Maize Ear Threshing – an Experimental Investigation (Yang Liqian, Wang Wanzhang, Zhang Hongmei, Wang Meimei, Hou Mingtao).....	34
Design, Development and Performance Evaluation of CIAE-Millet Mill (S. Balasubramanian, S. D. Deshpande, I. R. Bothe).....	42
Development of a Front Mounted Cultivator for Power Tiller (Sourav Srichandan Das, Hifjur Raheman).....	49
Development of Mathematical Model for	

Predicting Peel Mass of Cassava Tubers (John C. Edeh).....	55
Design Modification and Comparative Analysis of Cassava Attrition Peeling Machine (J. C. Edeh, B. N. Nwankwojike, F. I. Abam).....	63
Development a Table Top Centrifugal Dehuller for Small Millets (N. A. Nanje Gowda, Satishkumar, Farheen Taj, S. Subramanya, B. Ranganna).....	72
Design, Development and Evaluation of Manually-Operated Check Row Planter for Dry Sowing of Rice (Ajay Kumar Verma).....	79
Development of Semi Mechanised Tools for Cutting and Splitting of Jack Fruit for Bulb Separation (C. Nickhil, N. A. Nanje Gowda, B. Ranganna, S. Subramanya).....	84

◆ ◆ ◆  
**Vol.51, No.2, Spring 2020**

Could Conservation Tillage Farming Be the Solution for Agricultural Soils in Iraq? (Ali Mazin Abdul-Munaim, David A. Lightfoot, Dennis G. Watson).....	7
Design, Development and Testing of 4-Row Tractor Drawn Gladiolus ( <i>Gladiolus Grandiflorus L.</i> ) Planter for Uniformity in Corm Spacing (T. P. Singh, Vijay Guatam, Padam Singh, Santosh Kumar).....	10
Design and Development of Power Operated Walking Type Weeder (Ajay Kumar Verma).....	16
Optimization of Parameters of Axial Flow Paddy Thresher (Ritu Dogra, Desai Kishor Waman, Baldev Dogra, Ajeet Kumar).....	22
Measuring Spray and Spray Deposition on Plant and Unwanted in Field Under Iraqi South Conditions (Majid H. Alheidary, Qusay. Sameer, Abdul Salam G. Maki, Ali. F. Nasir).....	28
Current Situation and Perspectives for Soybean Production in Amur Region, Russian Federation (Boris Boiarskii, Hideo Hasegawa, Anna Lioude, Elizaveta Kolesnikova, Valentina Sinogovskaia).....	33
Development and Evaluation of Rasp Bar Mechanism for the Extraction of Onion ( <i>Allium Cepa L.</i> ) Seeds (R. Pandiselvam, R. Kailappan, Anjineyulu Kothakota, B. Kamalapreetha, G. K. Rajesh).....	39
Design and Development of Low Cost Multi-Row Manual Jute Seed Drill (V. B. Shambhu).....	46
Performance of Milking Machine at Different Vacuum Levels in Crossbred Dairy Cows Milked in Automated Herringbone Parlour (A. Fahim, M. L. Kamboj, A. S. Sirohi).....	52
Development of Integrated Small Scale Lac Processing Unit (S. C. Sharma, N. Prasad, S. K. Pandey, V. K. Bhargava).....	58
Design and Construction of a Farm Scale Evaporative Cooling System (Gürkan Alp Kağan Gürdil, Pavel Kic, Bahadır Demirel, Emel Demirbas Yaylagül).....	67
Development and Performance Evaluation of Tractor Drawn Cultivator Cum Spike-Roller (V. R. Vagadia, Rajvir Yadav, D. B. Chavda, Geeta Tomar, D. V. Patel).....	72
Development of Mat Nursery Raising and Uprooting Techniques for Paddy ( <i>Oryza Sativa L.</i> ) Crop and Their Field Evaluation with Mechanical Transplanter for South East Asia (Mahesh Kumar Narang, Rupinder Chandel, Baldev Dogra, Gursahib	

Singh Manes).....	79
-------------------	----

◆ ◆ ◆  
**Vol.51, No.3, Summer 2020**

<b>Specual Issue: VIM 90<sup>th</sup> Anniversary</b>	
The Federal Scientific Agro-engineering Center VIM: History of Foundation and Development (Andrey Yu. Izmailov, Yuliya S. Tsench, Yakov P. Lobachevsky).....	7
Technical Support of Vegetable Growing in Countries of the Eurasian Economic Union (Aleksandr G. Aksenov, Aleksei V. Sibirev).....	12
The Prospect of Using Gas Turbine Power Plants in the Agricultural Sector (Valentin A. Gusarov, Zakhid A. Godzhaev, Elena V. Gusarova).....	19
The State, Promising Directions and Strategies for the Development of the Energy Base of Agriculture (Andrey Yu. Izmaylov, Yakov P. Lobachevsky, Dmitry A. Tikhomirov, Anatoly V. Tikhomirov).....	24
Regional Features of Scientific-technical and Technological Modernization of Agro-industrial Sector of Bashkortostan at the Present Stage (Pavel A. Iofinov, Ildar I. Gabitov, Salavat G. Mudarisov, Denis A. Mironov, Badry H. Akhalaya).....	36
Technological Support of Soybean Cultivation (Aleksei S. Dorokhov, Marina E. Belyshkina, Ivan A. Starostin, Narek O. Chilingaryan).....	42
Strategy of Technical Support of Grain Harvesting Operations in Republic of Kazakhstan (Vladimir L. Astaf'ev, Vladimir A. Golikov, Eduard V. Zhalnin, Sergey A. Pavlov, Igor A. Pekhalskiy).....	46
The Methodology of Modeling and Optimization of Technologies in Crop Production (Vladimir V. Mikheev, Andrey G. Ponomarev, Pavel A. Eremin, Vladislav S. Mikheev).....	52
Benefits of Using Liquid Nitrogen Fertilizers for Russian Farm Enterprises (Leonid A. Marchenko, Igor G. Smirnov, Tatiana V. Mochkova, Rashid K. Kurbanov).....	58
Trends in the Use of the Microwave Field in the Technological Processes of Drying and Disinfection of Grain (Alexey N. Vasil'yev, Alexey S. Dorokhov, Dmitry A. Budnikov, Alexey A. Vasil'yev).....	63
The Main Stages of Agriculture Mechanization in Russia (Yuliya S. Tsench).....	69
The Choice of Combine Harvesters and Their Adapters for the Conditions of Northern Kazakhstan (Mikhail E. Chaplygin, Sergey V. Tronev, Igor A. Pekhalskiy).....	74
The Trend of Tillage Equipment Development (Sergey I. Starovoytov, Badri H. Akhalaya, Sidorov S. A., Mironova A. V.).....	77
N. A. Borodin's Firsthand Study of the USA Power Farming Experience: the Lessons from History (Roman A. Fando, Maria M. Klavdieva).....	82
Agricultural Robots in the Internet of Agricultural Things (Vyacheslav K. Abrosimov, Zakhid A. Godzhaev, Alexander V. Prilukov).....	87
Improving the Resource, Reliability and Efficiency of Worn-out Machines with New Methods of Their Maintenance (Anatoliy V. Dunayev, Sergey A. Sidorov).....	93

# SUBSCRIPTION/ORDER FORM

AGRICULTURAL MECHANIZATION IN ASIA, AFRICA AND LATIN AMERICA ( AMA )

Issued Quarterly

## AMA has Achieved an IMPACT FACTOR!!

AMA has been read by those involved in agricultural machinery and industry all over the world since the first publication in 1971. Thanks to many contributions from both the readers and writers, in 2012, we have achieved an Impact Factor, established by Thomson Reuters in U.S.A. AMA is the only Japanese agricultural machinery and industry related magazine which achieved an Impact Factor.

### Subscription Rate (includes surface mail postage)

Annual (4 issues)..... ¥ 8,000  
Single copy..... ¥ 2,500

(Check one)

- Please send me/us an invoice  
 I/We enclose remittance for ¥ \_\_\_\_\_  
 Please charge my/our credit card  
 VISA  
 MASTER Card. No. \_\_\_\_\_

Exp. date \_\_\_\_\_

Signature \_\_\_\_\_

We deeply appreciate your payment by credit card (NO EXTRA CHARGE NEEDED).  
We charge you extra 4,000 JPY when paid by check or wire transfer.

\*\*\*\*\*

Name: \_\_\_\_\_

Firm: \_\_\_\_\_

Position: \_\_\_\_\_

Address: \_\_\_\_\_

(block letters)

### FARM MACHINERY INDUSTRIAL RESEARCH CORP.

1-12-3 Kanda-Nishikicho, Chiyoda-ku, Tokyo 101-0054, Japan

Tel. +81-3-3291-3674, Fax. +81-3-3291-5717

URL: <http://www.shin-norin.co.jp>

E-Mail: [ama@shin-norin.co.jp](mailto:ama@shin-norin.co.jp)

## [Advertisers' Index]

Arimitsu Industry Co., Ltd. ....	14
Asaba Manufacturing Inc. ....	25
Cal Enterprise Co., Ltd. ....	25
Canycom Inc. ....	200-201
ChikushiGo Corporation ....	21
Delica Co., Ltd. ....	17
Honda Nouki kogyo Co., Ltd. ....	183
Iseki & Co., Ltd. ....	204
Ishii Factory Co., Ltd. ....	26
Kaneko Agricultural Machinery Co., Ltd. ....	8-9
Kawabe Noken Sangyo K.K. ....	23
Kett Electric Laboratory ....	16
Kiya Seisakusho Co., Ltd. ....	194
KOSHIN Ltd. ....	185
Kubota Corporation ....	2-3
Mametora Agric. Machinery Co., Ltd. ....	6-7
Maruyama Mfg. Co., Inc. ....	12-13
Matsui Waltersheid Ltd. ....	192
New Century Corporation (Manufacturer: Matsumoto Kiko Co.,Ltd.) ....	188
Matsuyama Plow Mfg. Co., Ltd. ....	4-5
Minoru Industries Co.,Ltd. ....	22

Mitsubishi Mahindra Agricultural Machinery Co., Ltd. .....	187
Morooka Co., Ltd. ....	10-11
Nichinokiseiko Co., Ltd. ....	184
Ochiai Cutlery Manufacturing Co., Ltd. ....	183
Ohashi Inc. ....	191
Orec Co., Ltd. ....	193
Otake Agricultural Machinery Co., Ltd. ....	19
Q-hoe Co., Ltd. ....	18
Sanyo Kiki Co., Ltd. ....	190
Shizuoka Seiki Co., Ltd. ....	20
SHOSHIN Co., Ltd. ....	189
Sugano Farm Machinery Mfg. Co., Ltd. ....	198-199
Sukigara Agricultural Machinery Co., Ltd. ....	24
Suzutec Co., Ltd. ....	15
Taisho Co., Ltd. ....	196-197
Taiyo Co., Ltd.; Taiyo India Pvt. Ltd. ....	184
Takakita Co., Ltd. ....	202-203
Tiger Kawashima Co., Ltd. ....	26
Wado Co., Ltd. ....	26
Yamabiko Corporation ....	195
Yamamoto Co., Ltd. ....	186
Yanmar Co., Ltd. ....	205

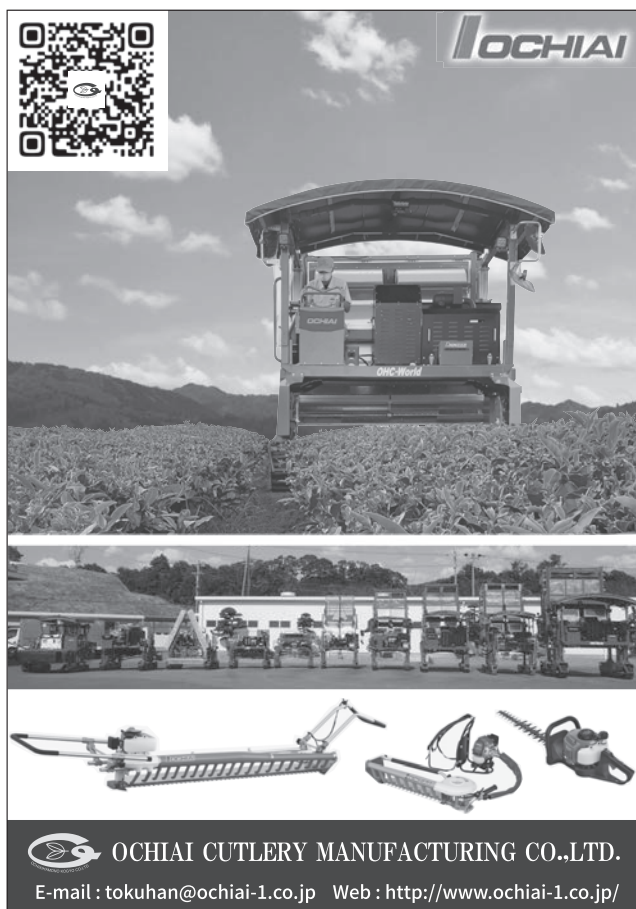

**OCHIAI CUTLERY MANUFACTURING CO.,LTD.**  
E-mail : tokuhan@ochiai-1.co.jp Web : http://www.ochiai-1.co.jp/



**HONDA**  
For Rich Farming  
Beneficial to You!

**Large Labor Savings of Harvesting Green-Soybeans**

**STABLE & STEADY!  
SMOOTH OPERATION!**

**GREEN-SOYBEAN PICKER 600**

stem/ leaf / unripe-grains  
Emissions out of the machines  
by Conveyor & Wind!

Harvest with less damage like a hand picking!  
With a simple structure,  
Maintenance-Free!

**HONDA NOUKI KOGYO Co., Ltd.** www.honda-nouki.com  
74, Kurisawa-cho, Kitahon-cho, Iwamizawa-shi, Hokkaido 068-0121, Japan  
TEL : +81-126-45-2211 FAX : +81-126-45-2212

## Sugar Beet Harvester



日農機製 株式会社

Nichinokiseiko Co., Ltd

1-13, Konan, Ashoro-cho, Ashoro-gun, Hokkaido 089-3727, Japan



# TAIYO

Rotary Tiller Blade

Born in Japan  
Make in India  
Now to the World



TAIYO Co., Ltd.

[www.k-taiyo.co.jp](http://www.k-taiyo.co.jp)



TAIYO INDIA PVT. LTD.

[taiyoindia.com](http://taiyoindia.com)





Since 1948  
**Japan Quality**

The global market leader trusted in 160 nations all over the world

## Agriculture



ENGINE PUMP

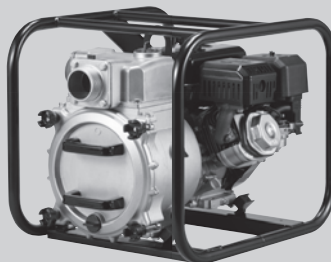

TRASH PUMP

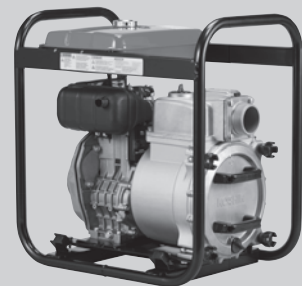

DIESEL TRASH PUMP



ENGINE PUMP

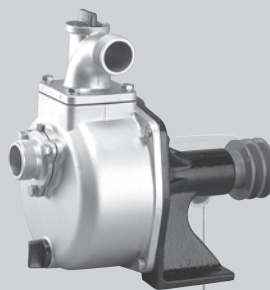

PABOOL PUMP



SUBMERSIBLE PUMP



LITHIUM BATTERY SPRAYER



ENGINE SPRAYER



GENERATOR

# KOSHIN



12 Kami-Hachinotsubo, Kotari,  
 Nagaokakyo city, Kyoto, 617-8511, Japan

✉ [Info@koshin-ltd.co.jp](mailto:Info@koshin-ltd.co.jp) [www.koshinpump.com](http://www.koshinpump.com)



# We create future of agriculture.



## Grain Dryer

SD-300H  
SD-120H3

The most dependable  
dryer in Japan.

High durability.

Superior drying  
performance.



## Abrasive Whitener

XPA-25

Grinding gently the surface  
of brown rice helps to raise  
the efficiency of friction for  
next process.



## Friction Polisher

XPF-50

Through gravity, the rice  
flows downward with  
uniform pressure. It helps to  
get high yield.



# YAMAMOTO CO., LTD.

5800-1, Higashine-ko, Higashine-shi, Yamagata-ken, 999-3701 JAPAN

<http://world.yamamoto-ss.co.jp>

E-Mail: [world@yamamoto-ss.co.jp](mailto:world@yamamoto-ss.co.jp)

Tel: 81-237-51-1004 Fax: 81-237-43-8820



**MITSUBISHI  
TRACTOR**

~ Long Life ~ Long and Strong Life for Human and Tools

# EAGLE DESIGN Tractor Series



**GOOD DESIGN  
AWARD 2020**



**GCR1380**

**GM**

**GS**

**GAGAK**

**MITSUBISHI MAHINDRA AGRICULTURAL MACHINERY CO., LTD.**

2-133-4, Sakurada, Kuki, Saitama, 340-0203 Japan  
<https://www.mam.co.jp>

# VALLIANT TEA HARVESTER [MCT-E-6FS] SINCE 1981

**MATSUMOTO KIKO CO., LTD.**

**Reliable  
Advanced  
Technology**

**Efficiency**  
One operator covers  
5ha/day on average

**Available in  
different sizes**  
Max. bush width is  
3300mm



**WE**  
continue  
evolving  
to meet  
customer  
needs

**Supplied By :NEW CENTURY CORPORATION**

TEL: +81-3-6264-8417 EMAIL: [ncc@newcentury-japan.com](mailto:ncc@newcentury-japan.com)

# NEW 3S Debut!



## SHOSHIN SPEED SPRAYER

A new model from Shoshin Speed Sprayer with a high market share in Japan has appeared. It is equipped with a 4-cylinder diesel turbocharged engine that complies with Tier 4 exhaust gas regulations and has achieved low noise and low vibration. In addition, the large-diameter curved-blower fan and wind-tunnel waveform static blades are used to achieve both high air volume and quietness. It also features HST-driven driving and LED combination meters for a comfortable ride. This is a new product of high-functional beauty that specializes in the design of Shoshin's unique design.



2156 Ogawara, Suzaka City, Nagano, Japan  
<http://www.shoshin-ss.co.jp>  
contact <http://www.shoshin-ss.co.jp/contact/>

# SANYO KIKI CO.,LTD

## Introduction of Products

### Loading Machinery Family



Categories : GLD, HLD, PLD, SAN  
Helpful to clear snow,  
level paddy fields,  
carry crops, and so on

### RC Mower



Categories : AJK  
Mowing width : 600mm  
Cutting blade type : Blade + Free Knife

### Hydraulic and Control Equipment Family



Cylinders, Valves,  
Hydraulic taking-out kit,  
Hydraulically electric control system

### Compact Loading Machinery Family



Categories : SCLD, CLD  
Helpful to clear snow,  
level paddy fields,  
carry crops, and so on

### Mowers Family



Rotary Mower : Installed in tractor  
Mowing width : 800mm/900mm  
Hammer-Knife Mower : Installed in tractor  
Mowing width : 900mm/1000mm

### Lifters Family



Air-pressure Lifter  
Lifting-up power : 150kgf  
Wire Lifter  
Lifting-up power : 70kgf

## SANYO KIKI CO.,LTD

3858 Shinjo, Satoshochi, Asakuchigun, Okayama, 719-0392 JAPAN

Phone : 0865-64-2871 Fax : 0865-64-2874

URL <https://www.sanyokiki.co.jp/> E-mail [san@sanyokiki.co.jp](mailto:san@sanyokiki.co.jp)



## The wood chipper specialist for over 20 years



**7cm ~ 50cm**

### CHIPS



**MATSUI-W**

**MATSUI WALTERSCHEID LTD.**  
**MATSUI GROUP**  
SINCE 1980

# PTO Drive Shafts

Continuously seeking to provide customers with globally optimized products

## HIGHER DURABILITY FOR MUDDY WATER

ISO 9001 / 14001  
**Certified**

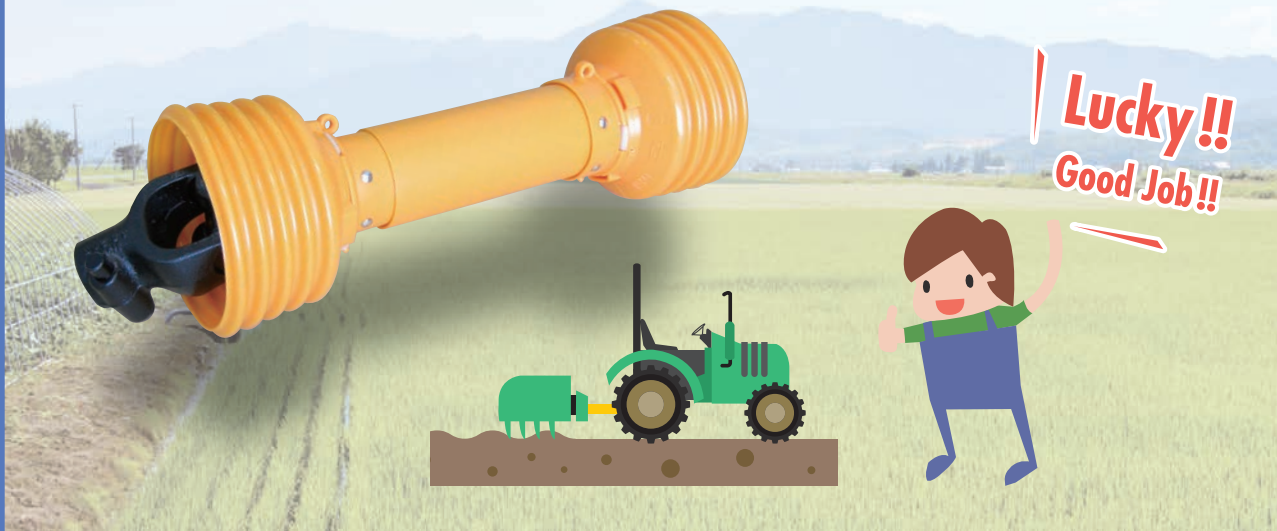

We, Matsui-Walterschied Ltd., are specialist of manufacturing for agricultural use PTO Drive Shafts.

## **NEW** Overload Clutches

600~1200 N·m  
1300~3000 N·m



Exhibition scenery

Expert of PTO Drive Shafts

**MATSUI WALTERSCHEID LTD.**

937-5 Komagome, Koga-city, Ibaraki 306-0126 Japan TEL: +81-280-75-1321 FAX: +81-280-76-6700  
URL: <http://www.matsui-w.com/> E-mail: [info@matsui-w.com](mailto:info@matsui-w.com)





## WORK SMARTER NOT HARDER

We at OREC are inspired by our customers to continuously improve and innovate. We know that you work hard, and we want to put our equipment to work for you, to save time and energy. We're all about helping you and your team work smarter, not harder.



 **RABBIT MOWER** Riding Brush Mower



 **BULL MOWER** Flail Mower



 **AUTO MOWER** Brush Mower



 **ACE ROTOR** Farming Tiller



Mail: [boeki@orec-jp.com](mailto:boeki@orec-jp.com)

Youtube



Facebook





**PRESS SHEET METAL/  
WELDING/PAINTING  
LEAVE IT TO US!  
We can do it!**

KIYA seisakushoCo., Ltd. was founded as an agricultural machinery manufacturer ▶▶▶



Awn-removal & Seeding Thresher(combined use)



Awn-removal & Grain Adjuster



Soybean Peanut Shedding Machine



Soybean Sorter

**SIDE GUARD**



AL (aluminium)



IRON

**Currently, Cars, Trucks, etc.  
We manufacture parts,  
we support your agriculture  
from logistics side.**

**DECK**



AL



IRON



Compressor BKT



Bumper Step

**- Features of Kiya Seisakusho -**

**POINT 1**

Without mold  
With cost reduction  
Achieve shortened  
Delivery time

**POINT 2**

Proposal /  
Interactive  
approach for  
manufacturing

**POINT 3**

Quality Manage-  
ment System  
“Self Process-  
Complete type”



**KIYA Seisakusho Co., Ltd.**

502-3, Moroyamacho-Ichiba, Iruma-Gun, Saitama 350-0434, Japan  
TEL: +81-49-299-7779 FAX: +81-49-299-7880

[www.kiya-ss.co.jp](http://www.kiya-ss.co.jp)



## Excellent field management and Optimized yield by KIORITZ

70 years engineering expertise made KIORITZ best fit and reliable in various farmland. Technologies developed by KIORITZ original developers have been evolving into modern precision farming. KIORITZ makes farming easier, productive and sustainable.



**Speed Sprayer**



**Self-propelled Sprayer**



## WE ARE ECHO



### 100% PROFESSIONAL GRADE

ECHO only builds equipment to one standard – professional. We manufacture products to suit the environment in which they will be used and the job they will be doing, and each piece of equipment is as durable as we can make it. We test our products in punishing conditions to ensure that they are capable of whatever you demand from them. So even if you don't use ECHO equipment professionally, the products you buy are already being used by people who do.



### JAPAN TECHNOLOGY

You know that equipment designed in Japan will be reliable. Well built. Dependable. Professional. Durable. Japan is the home of technological craftsmanship and the nation has won international respect for its manufacturing expertise. This global standard also extends to the equipment we manufacture and we are proud to be counted among those companies that help Japan maintain its reputation for the quality of its engineering and technology.

Visit our website for more information  
[www.echotools.com](http://www.echotools.com)

Follow us on Facebook for the latest news  
<https://www.facebook.com/echotools/>



[www.echotools.com](http://www.echotools.com)



### YAMABIKO CORPORATION

7-2, Suehirocho 1-Chome, Ohme, Tokyo, 198-8760  
Web: <https://www.yamabiko-corp.co.jp/>

Phone: +81-428-32-6118 Fax: +81-428-32-6145  
Email: [sales@yamabiko-corp.co.jp](mailto:sales@yamabiko-corp.co.jp)

Changes from technology  
to HUMANOLOGY to live with nature

**TAISHO**

We make the most of customers' viewpoint and best quality of products. Enhancing the spirit of cooperation and executive talent, we contribute to the development of agriculture.

## BLEND BROADCASTER

# ATLAS

Properly blend fertilizers with  
different specific gravity



- Suitable for organic soil preparation !

DSB-1630

## FERTILIZER SPREADER

# GRAND SOWER

RS SERIES RD SERIES

Broadcast various type of fertilizer  
(powder, granules, fine granules, chicken manure, organic pellets, etc.)  
properly without waste

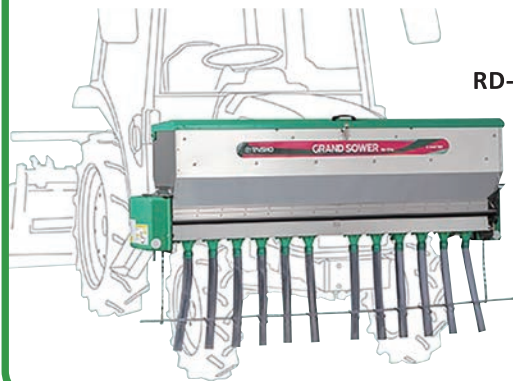

RD-1714

**FERTILIZER SPREADER**  
**GRAND SOWER**  
 UX-GP SERIES

Accurate spreading based on GPS



UX-110F-GP • Car speed-interlocking type with a GPS antenna

**NURSERY TRAYS**  
**SET-UP MACHINE**  
**Belno**

Minimize set-up time of nursery trays



BW-3A

**GRAIN CARRYING MACHINE**  
**GRAIN**  
**CONTAINER**

For transportation of postharvest rough rice



• Rough rice carrying from combine is available !

UMK11

**STEAM**  
**GERMINATION**  
**DEVICE**

Assist germination even under low temperature

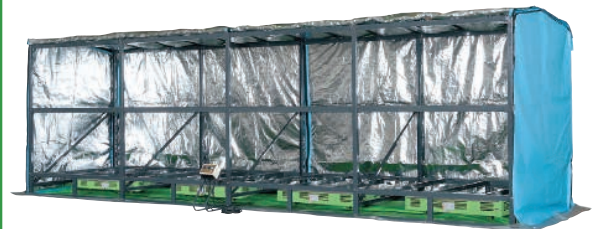

• Fit for forklift. Easy to take seeding box in and out

FCX-1000

**TAISHO Co., Ltd.**

1027 Motoyoshidacho, Mito City, Ibaraki, 310-0836, Japan  
 TEL. +81-29-247-5411 FAX. +81-29-248-2172 URL. <https://www.taisho1.co.jp/>



We promote 'Tsuchi-tsukuri'  
since 1917

# Tsuchi-tsukuri

There is no English word corresponds to ‘Tsuchi-tsukuri’, which is not only a traditional but also modern practice to maintain and improve soil productivity in Japan.

‘Tsuchi-tsukuri’ describes as ‘producing soil’ in Kanji character. Actual practice of ‘Tsuchi-tsukuri’ is composed of periodical deep plowing, incorporating well matured manure (both green and animal) into not only top soil but also subsoil.

‘Producing’ explicitly means caring, conserving, growing soil by farmers.

We consider a feasibility of achieving sustainable agriculture through preventing soil and land degradation with this unique concept of ‘Tsuchi-tsukuri’ at soil by soil.

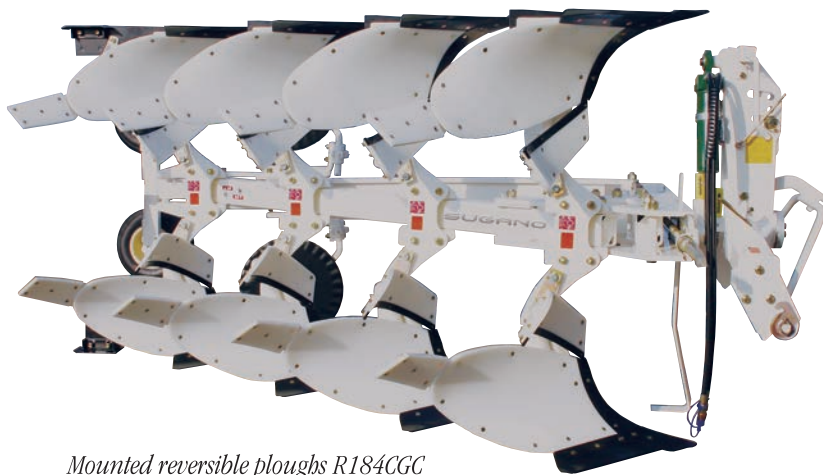

*Mounted reversible ploughs R184CGC*

**SUGANO**  
LISTEN TO THE SOILS

SUGANO FARM MACHINERY MFG. CO., LTD.

Head Office : 300, Tenjindai, Mano, Miho-mura, Inashiki-gun, Ibaraki-pref, 300-0405, Japan <https://www.sugano-net.co.jp>

**CANYCOM**

RIDE-ON BRUSH CUTTER



RUBBER TRACK FLAIL BRUSH CUTTER





RUBBER TRACK HEAVY-DUTY CARRIER

# Takakita

Our company will continue to create new technologies, establish trust and make positive impressions through our eco-friendly manufacturing.



▲ General-purpose Forage Combination Harvesting-baler  
**SMR1020MH2**

HEAD OFFICE  
2828 Natsumi Nabari-city Mie, 518-0441, JAPAN  
Phone:+81-595-63-3111 Fax:+81-595-64-0857



▲ Rake, Bale-wrapper Combination  
**VCW1620**



▲ Variable Diameter Round Baler  
**VC1100**

**NEW**



▲ Chopping Whole Crop Harvesting-baler  
**WB1040DX**

*get familiar with  
the earth  
and living with  
the earth*

Takakita Co., Ltd.

[www.takakita-net.co.jp](http://www.takakita-net.co.jp)

**W**e are one of the leading agricultural machinery companies in Japan  
and our innovative technologies are appreciated in many countries worldwide.

**With our expanding global sales and service network, we will continue contributing  
to the food supply and creation of a sustainable society across the world.**



# **ISEKI & CO., LTD.**

**5-3-14, Nishi-Nippori, Arakawa-ku, Tokyo, 116-8541, JAPAN**

**+81-(0)3-5604-7602**

**[www.iseki.co.jp](http://www.iseki.co.jp)**



**YANMAR**

# A SUSTAINABLE FUTURE

— New Value through Technology —



## SMARTASSIST

**Farm smarter with high-tech solutions.**

Advanced technology will support your agricultural business using innovative ways.

Whenever you are, whenever you go, whenever you work, Yanmar is right there for you.

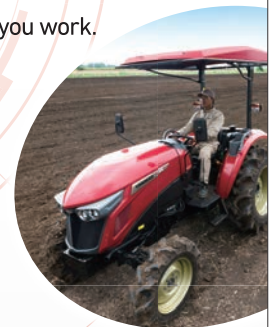

Watch more information

YANMAR CO.,LTD. [www.yanmar.com/](http://www.yanmar.com/)

