

International specialized medium for agricultural mechanization in developing countries

ISSN 0084-5841

AMA

AGRICULTURAL MECHANIZATION IN ASIA, AFRICA AND LATIN AMERICA

VOL.43, No.3, SUMMER 2012

A M A - AGRICULTURAL MECHANIZATION IN ASIA, AFRICA AND LATIN AMERICA

VOL.43, NO.3, Summer 2012

FARM MACHINERY INDUSTRIAL RESEARCH CORP.

Well-ventilated woven combine bag series

DX RICERON®

(with upper and lower handle)



The handles on both the top and bottom make work much easier! for harvesting and drying rice, wheat, and beans!

characteristics

- The handles on both the upper and lower parts make carrying and unloading easier.
- Its good ventilation helps prevent sweating.
- The slipping of the contents and stretching of the material are minimized as it is woven with angular threads.
- Its good permeability allows remaining contents to be spotted easily.

Double-handled and easy to carry!

Chestnut Bags



Large enough to hold about 20 kilograms of chestnuts!



580mm×600mm

Millet Bags

for small grains such as foxtail millet, japanese barnyard millet, proso millet, and sesame.



580mm×800mm



Tanaka Industries, Inc.

Main Branch: Hama 1-26-21, Toyonaka-shi, Osaka, Japan 561-0817
TEL: +81(0)6-6332-7185 FAX: +81(0)6-6336-2623

HP: <http://www.tanakasangyo.com>
e-mail: info@tanakasangyo.com

An Innovation in the age of combines! How to dry rice, wheat, beans, and the like with a flat dryer while they are still packed in bags.



An Episode in Product Development

The development of RICERON began with advice from Professor Yusaku Nakahashi of the Hyogo Prefectural Agricultural Experiment Station, when head-feeding combines had been rapidly spreading since around 1970. Much brewer's rice

was grown in Hyogo Prefecture due to its large number of saké breweries, which were famous all across the country. However, the saké breweries sometimes refused the rice because of the "sweating of rough rice" that occurred when it is kept too long, which resulted in lower quality.

In order to sell combine machines, manufacturers of agricultural machinery at the time were producing many affordable cross-woven polypropylene combine bags, which had poor ventilation. Professor Nakahashi's stated that "Rough rice and wheat are still alive and breathing after they are reaped, so biologically speaking, being stuffed in a poorly ventilated cross-woven bag must be very hot and stifling." This resonated with the first president of Tanaka Industries, Inc., and thus he developed RICERON and completed it three years later.

"RICERON" weaves combine bags, which we applied for in 1971 as a utility model, laid the foundations for the company as a manufacturer of agricultural materials that offers unique products that cannot be found anywhere else. Since then, RICERON has become a hit product which sold at 300 thousand units in 1975, 600 thousand units in 1976, 1 million units in 1977, and 2 million units

in 1979. Behind the rapid spreading of RICERON were added values of its feature of being well-ventilated to help reduce the sweating of rough rice, such as 1) its allowing of raw rough rice to be temporarily stored and predried, 2) its allowing of complete drying with flat dryers and rush dryers, 3) its keeping of rough rice from sweating when huge amounts are collected at cooperative drying facilities such as country elevators, and 4) its usefulness in the production of quality rice.

There are two reasons why RICERON bags are blue. The first reason is that the blue color lets infrared rays in and keeps ultraviolet rays out so that the number of cracked rice grains is significantly reduced. The second reason is because of the results of verification tests held at the Hyogo Prefectural Kaibara Agricultural Improvement and Extension Center in November 1974. Although cross-woven polypropylene ages after being exposed to sunlight for forty to fifty days, polyethylene that is manufactured with the medium-low pressure method does not lose its durability even after three years of being exposed to sunlight.

The added value of meeting actual needs first and the added value of keeping up with the times has gradually led RICERON to become a major hit on the market. During the twelve years that have been spent on product development, tests have been conducted in sixteen public experiment stations in sixteen locations across Japan. Tanaka Industries is sure that the customers will see the passion that they feel for their products. To this day, they still have the data from their tests preserved as research achievements. They believe that the extensive testing that has been conducted at public experiment stations is what still makes RICERON a popular item among practical farmers even thirty years after its initial development.

Flat-bed Dryers



Please be sure to fill 70% with rough rice.

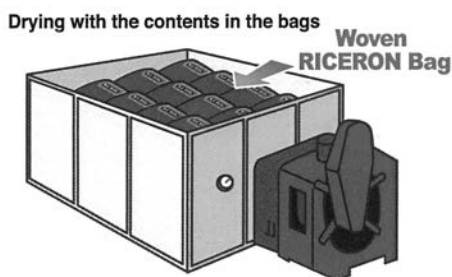

Example: The correct way to line bags

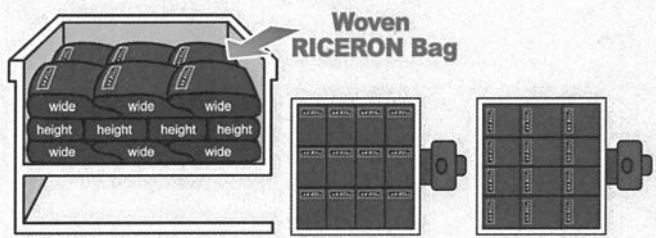

Note: Please rotate the bags when stacking them in three layers or more. Dry properly and evenly.



AGRICULTURAL MACHINERY



We Look Forward To
Extend Agribusiness
With Global-Minded People.

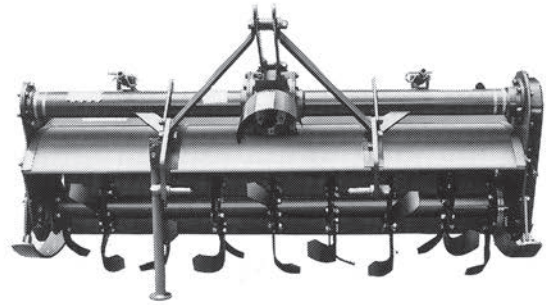

Model: SX-1600NA (25 ~ 40HP)
SX-1700NA

Main Niplo Products

ROTARY TILLER
DRIVE HARROW
FLAIL MOWER
DEEP ROTARY TILLER
DIGGER
SEEDER

MATSUYAMA PLOW MFG. CO., LTD.

Head Office & Factory

Head Office & Factory: 5155, Shiokawa, Ueda-shi, Nagano-ken, 386-0497, Japan

Telephone: +81-268-42-7504 Fax: +81-268-42-7528



*Photo is our new
product of GPS
fertilizer spreader.

Model.MGC600WN▲



IHI STAR has
manufactured wide
range of agricultural
machinery and
provided good
solutions to farmers
since 1924.

E-mail : star@ihi-star.com

URL : <http://www.ihi-star.com/english>

IHI STAR Machinery Corporation

Head Office : 1061-2, Kamiosatsu, Chitose-shi, Hokkaido, 066-8555, Japan

Telephone : +81-123(26)2210

International specialized medium for agricultural mechanization in developing countries

ISSN 0084-5841

AMA

AGRICULTURAL MECHANIZATION IN ASIA, AFRICA AND LATIN AMERICA

VOL.43, No.3, SUMMER 2012

Edited by

YOSHISUKE KISHIDA

Published quarterly by

Farm Machinery Industrial Research Corp.

in cooperation with

The Shin-Norinsha Co., Ltd.

and

The International Farm Mechanization Research Service

TOKYO

Yoshisuke Kishida, Publisher & Chief Editor

Contributing Editors and Cooperators

- AFRICA -

Kayombo, Benedict (Botswana)
Fonteh, Fru Mathias (Cameroon)
Abdallah, Said Elshahat (Egypt)
El Behery, A. A. K. (Egypt)
Pathak, B. S. (Ethiopia)
Bani, Richard Jinks (Ghana)
Djokoto, Israel Kofi (Ghana)
Some, D. Kimutaiarap (Kenya)
Houmy, Karim (Morocco)
Bindir, B. Umar (Nigeria)
Igbeka, Joseph C. (Nigeria)
Odigboh, E. U. (Nigeria)
Oni, Kayode C. (Nigeria)
Bindir, Umar B. (Nigeria)
Opara, L. U. (South Africa)
Kuyembah, N. G. (Sierra Leone)
Abdoun, Abdien Hassan (Sudan)
Saeed, Amir Bakheit (Sudan)
Khatibu, Abdissalam I. (Tanzania)
Baryeh, Edward A. (Zimbabwe)
Tembo, Solomon (Zimbabwe)

- AMERICAS -

Cetrangolo, Hugo Alfredo (Argentina)
Naas, Irenilza de Alencar (Brazil)
Ghaly, Abdelkader E. (Canada)
Khan, Alamgir (Canada)
Hetz, Edmundo J. (Chile)
Valenzuela, A. A. (Chile)
Aguirre, Robert (Colombia)
Ulloa-Torres, Omar (Costa Rica)
Magana, S. G. Campos (Mexico)
Ortiz-Laurel, H. (Mexico)
Chancellor, William J. (U.S.A.)
Goyal, Megh Raj (U.S.A.)
Mahapatra, Ajit K. (U.S.A.)

- ASIA and OCEANIA -

Quick, G. R. (Australia)
Farouk, Shah M. (Bangladesh)
Hussain, Daulat (Bangladesh)
Mazed, M. A. (Bangladesh)
Wangchen, Chetem (Bhutan)
Li, Shujun (China)
Wang, Wanjun (China)
Illangantileke, S. (India)
Ilyas, S. M. (India)
Mani Indra (India)

Mehta C. R. (India)
Michael, A. M. (India)
Ojha, T. P. (India)
Salokhe, Vilas M. (India)
Singh, Gajendra (India)
Verma, S. R. (India)
Soedjatmiko (Indonesia)
Behroozi-Lar, Mansoor (Iran)
Minaei, Saeid (Iran)
Ali Mazin Abdul-Munaim (Iraq)
Sakai, Jun (Japan)
Snobar, Bassam A. (Jordan)
Chung, Chang Joo (Korea)
Lee, Chul Choo (Korea)
Bardaie, Muhamad Zohadie (Malaysia)
Pariyar, Madan (Nepal)
Basunia, M. A. (Oman)
Chaudhry, Allah Ditta (Pakistan)
Mughal, A. Q. (Pakistan)
Rehman, Rafiq ur (Pakistan)
Devrajani, Bherular T. (Pakistan)
Abu-Khalaf, Nawaf A. (Palestine)
Nath, Surya (Papua New Guinea)
Lantin, Reynaldo M. (Philippines)
Venturina, Ricardo P. (Philippines)
Al-suhaibani, Saleh Abdulrahman (Saudi Arabia)
Al-Amri, Ali Mufarreh Saleh (Saudi Arabia)
Chang, Sen-Fuh (Taiwan)
Peng, Tieng-song (Taiwan)
Krishnasreni, Suraweth (Thailand)
Phongsupasamit, Surin (Thailand)
Senanarong, Akkapol (Thailand)
Pinar, Yunus (Turkey)
Haffar, Imad (United Arab Emirates)
Lang, Pham Van (Viet Nam)
Nguyen Hay (Viet Nam)
Hazza'a, Abdulsamad Abdulmalik (Yemen)

- EUROPE -

Kaloyanov, Anastas P. (Bulgaria)
Kic, Pavel (Czech)
Müller, Joachim (Germany)
Pellizzi, Giuseppe (Italy)
Hoogmoed, W. B. (Netherlands)
Pawlak, Jan (Poland)
Marchenko, Oleg S. (Russia)
Kilgour, John (U.K.)
Martinov, Milan (Yugoslavia)

EDITORIAL STAFF

(Tel.+81-(0)3-3291-3674)

Yoshisuke Kishida, Chief Editor
Masako Terauchi, Managing Editor
Zachary A. Henry, Editorial Consultant

ADVERTISING

(Tel.+81-(0)3-3291-3674)

Yuki Komori, Manager (Head Office)
Advertising Rate: 300 thousand yen per page

CIRCULATION

(Tel.+81-(0)3-3291-3674)

(Fax.+81-(0)3-3291-5717)

Editorial, Advertising and Circulation Headquarters
1-12-3, Kanda Nishikicho, Chiyoda-ku, Tokyo 101-0054, Japan

URL: <http://www.shin-norin.co.jp>

E-Mail: ama@shin-norin.co.jp

Copyright © 2012 by

FARM MACHINERY INDUSTRIAL RESEARCH CORP.
in SHIN-NORINSHA Co., Ltd

Printed in Japan

EDITORIAL

In early July this year, the “International Conference of Agricultural Engineering” was held in Valencia, Spain. The organizers of this huge event were CIGR and EurAgEng, which made the event a joint conference. Nearly 1,500 visitors attended the conference from all over the world, and it was definitely an energetic international conference. A number of presentations were made, showing the result of various research. Many of the themes were related to agricultural mechanization. All the rooms holding sessions about agricultural mechanization of developing countries were filled with participants. It is known by everyone that the food problem among developing countries is a priority issue, especially related to the growing global population.

The world population has grown to more than seven billion, which is estimated to be an overwhelming 10 billion in 2050.

Regardless of this situation, the farmland left on earth is obviously limited. People must make full use of this limited land resource to supply food for the whole world. We need to increase the land productivity and work precisely for the long-term conservation of farmland. Still, many small farmers do exist in developing countries. The task is to promote agricultural mechanization just for them and improve the related technologies.

“Sustainability” is the keyword people frequently use nowadays. In fact, for the human being to continuously survive on this planet earth for a long time, we need to realize the harmony between the human being and other vital systems. To make this a reality, we need research from different points of view. Promoting new agricultural work on production systems, based on appropriate and scientific knowledge, is also a key to success.

In the 21st century, newly developing countries are expected to grow more than developed countries in terms of agriculture and agricultural mechanization. To supply the needed agricultural machinery, it is important to grow the local agricultural industry. During the international conference of CIGR, there were many participants other than researchers from institutes and universities. Many of them were from the industrial world. To give people plenty of food and a beautiful environment, worldwide cooperation among the agricultural engineering experts is necessary.

I strongly hope for AMA to be one of the keys to accelerate this cooperation.

Yoshisuke Kishida
Chief Editor

July, 2012

CONTENTS

AGRICULTURAL MECHANIZATION IN ASIA, AFRICA AND LATIN AMERICA

Vol.43, No.3, Summer 2012

Yoshisuke Kishida	7	Editorial
Elsamawal Khalil Makki Lyla Saeed Jamaa	9	Animal Traction in Sudanese Agriculture, A Comparative Study
S. P. Singh, Pratap Singh Surendra Singh	15	Design and Development of Hand Operated Maize Dehusker-Sheller for Farm Women
M. A. Basiouny Said Elshahat Abdallah	22	Evaluating The Performance of a Bulk-Milk Cooler on a Dairy Farm
Abd El-Hameed, S. E. Bader A. E. Elyamani	32	Development in a Small Prototype Gin Stand for Egyptian Cotton
Radhey Shyam Singh L. P. Gite	41	Technological Change in Paddy Production: A Comparative Analysis of Traditional and Direct Seeding Methods of Cultivation
A. H. Soliman, M. E. El-Iraqi S. E. El Khawaga, T. R. Awais	47	New Mechanical Picking Head for Peach Harvesting
V. B. Shambhu, S. K. Jha	55	Problems and Prospects of Agricultural Mechanization in Bihar, India
Jafar Massah, Ahmad Lotfi Akbar Arabhosseini	60	Effect of Blade Angle and Speed of Onion Harvester on Mechanical Damage of Onion Bulbs
M. P. Chandra, S. C. Sharma	64	Anthropometric Analysis of Selected Body Dimensions of Farm Workers for Design of Agricultural Implements – An Approach
Vijaya Rani, A. P. Srivastava	69	Design and Development of Onion Detopper
Dushyant Singh, KP Saha, SP Singh	74	Adoption of Skill Enhancement Techniques and Quality Improvement in Manufacturing of Agricultural Implements in Madhya Pradesh, India
Xingye Zhu, Shouqi Yuan Hong Li, Junping Liu	79	Flow Characteristics of a Wall-Attaching Offset Jet in a Complete Fluidic Sprinkler
	78	ABSTRACTS

★

★

★

NEWS.....	14, 68, 86
New Co-operating Editors	31
Book	40

Co-operating Editor	87
Back Issues.....	91
Instructions to AMA Contributors	93

Animal Traction in Sudanese Agriculture, A Comparative Study

by
Elsamawal Khalil Makki

Lyla Saeed Jamaa

School of Rural Extension, Education and Development (REED)
Ahfad University for Women, Omdurman SUDAN
sammakki@hotmail.com

Abstract

This study investigated the similarities and differences of animal traction in different farming systems in the Sudan. It followed the cross-sectional survey design in three farming sites: Dongola, Alhagize and Shambat. Field data were collected from a sample of 30 farmers in each site. Dependency of selected parameters on farming site was tested using the chi square test. The results revealed several differences between the three sites in animal types, feeding practices and farming operations with relative similarities between Dongola and Shambat. Farmers in the three sites face many problems relating to harness and tools manufacture and repair on one hand, and extension and capacity building on the other.

Introduction

Throughout the developing world and in many developed countries draught animals are an inseparable part of agriculture. While agriculture undergoes modernization in many areas, the use of draught animals persists and is even expanding.

The role of animal traction in agriculture is well documented and

presented worldwide. The technology continues to make a significant contribution to livelihoods of the families in the rural area and in fields that are difficult for tractors, or when the income does not justify purchasing it (Ajva, 2000 and FAO, 2000).

Sudan with its high potential of agricultural development has three dominant agricultural sub-sectors. These are: modern irrigated, mechanized rainfed and traditional rainfed sub-sectors. The latter is the largest one and constitutes about 4 million hectares. Farmers in this sector are characterized by having small operational farms of 1-2 hectares size and using traditional-primitive technologies in farming. The limited inputs of physical energy, capital and technical know-how confines this sector to subsistence level of production (Mahmoud, 1982).

Animal traction in the Sudan is used in different patterns and forms. While it has been traditionally used for centuries along the Nile valley, the technology has been recently introduced to Kordofan and Darfur States through the intervention of many NGOs; with Action Plan (formerly Intermediate Technology Development Group – ITDG) taking the leading role in Darfur. Earlier intervention in animal traction was

shouldered by the Western Savannah Development Project in the late 1980s (Mohamed, 2001).

This paper argues that the employment of animal traction in agriculture is decisively influenced by differences in the farming system in which it is employed. Attempts are made to explore the similarities and/or differences in the animal traction situation in three farming areas in the Sudan under the general hypothesis that differences in farming systems results in differences in types of animals, operations in which animal traction is used, harnessing techniques and animal husbandry practices.

Objectives

The study was conducted to identify and compare the similarities and differences in Drought Animal Technology (DAT) in Shambat (Khartoum State), Dongola (Northern State) and Alhagize (South Kordofan State) as influenced by spatial differences that relate to differences in farming systems.

Justification

Draught animal technology was introduced to Sudan through two ways; either by immigrants (in places near the Nile) or by diffusion through organizations (in the tradi-

tional rainfed farming areas). Therefore, one expects to find differences or similarities regarding the farming system itself, types of animals used along with the reason, type of harness and other differences or similarities that stem from spatial and cultural variation. This comparative study aims to show these differences considering the lack of published data and information in such a field at the local and national levels.

Materials and Methods

Field data for this exploratory-comparative study was collected from Alhagize village (South Kordofan State), Dongola (Northern State) and Shambat (Khartoum State). The location of the three sites is shown on the country map (Fig. 1).

Study Areas

Alhagize is located in the sandy soil sector of Dilling locality, south Kordofan state (longitude 24° 12' E and latitude 10° 4' N). Traditional rainfed farming is the main livelihood of most of the population. The vegetation cover in the area is poor savannah and the soil is characterized by loss of fertility and low yields. The rainy season starts in May and ends in October, while harvest starts in November and ends in March. The main crops grown in the area are sorghum, groundnuts, millet; cowpea, hibiscus and okra mostly on far sites from the village.

Dongola (also spelled Dunqulah or Dunqula) and formerly sometimes as (AL-Urdi), is the capital of the Northern State in Sudan (longitude 30° 28' E and latitude 19° 10' N). It should not be confused with (old Dongola) an ancient city located

50 miles up stream on the opposite bank of the River Nile. Farming is confined to the River banks with little production on the high terrace whenever the soil allows. Beyond, the Nubian Desert stretches eastwards and westwards the Libyan Desert. Most of the population depends on farming with growing date palms, vegetables, fodders, legumes and wheat; mainly as winter season crops. Fodder crops are intercropped with date palm trees.

Shambat area lies on the right bank of the River Nile in Khartoum, the capital of the country (longitude 32° 32' E and latitude 15° 40' N). As in Dongola, farming is confined to the River banks on a comparatively wider silt plain. Farmers produce different types of vegetables including perishable ones and a few forage crops. Being located in a metropolitan area stimulates farmers to specialize in vegetable production with a purchasing community on one hand, and to consider fodders in a zero grazing area. Farmers in this area are traditionally migrants from northern and western Sudan.

Farm sizes are comparatively similar in Khartoum and Dongola with a general trend of small to medium size plots (1-5 and 6-10 feddans, respectively). This is dictated by the limited available area along the Nile valley and the fragmentation of plots by inheritance through generations. In Alhagize farm sizes are medium to large (6-10 and 11-15 feddans, respectively).

Data Collection

A sample of 30 farmers was selected from each of the three sites following the systematic random sampling technique by selecting the first of each three farmers starting with the upper end of each study site. The study followed the cross-sectional survey design with three clusters (study sites). Data were collected using one type of questionnaire that covered aspects of animal types and work, harnessing, animals

Fig. 1 Study sites on the map

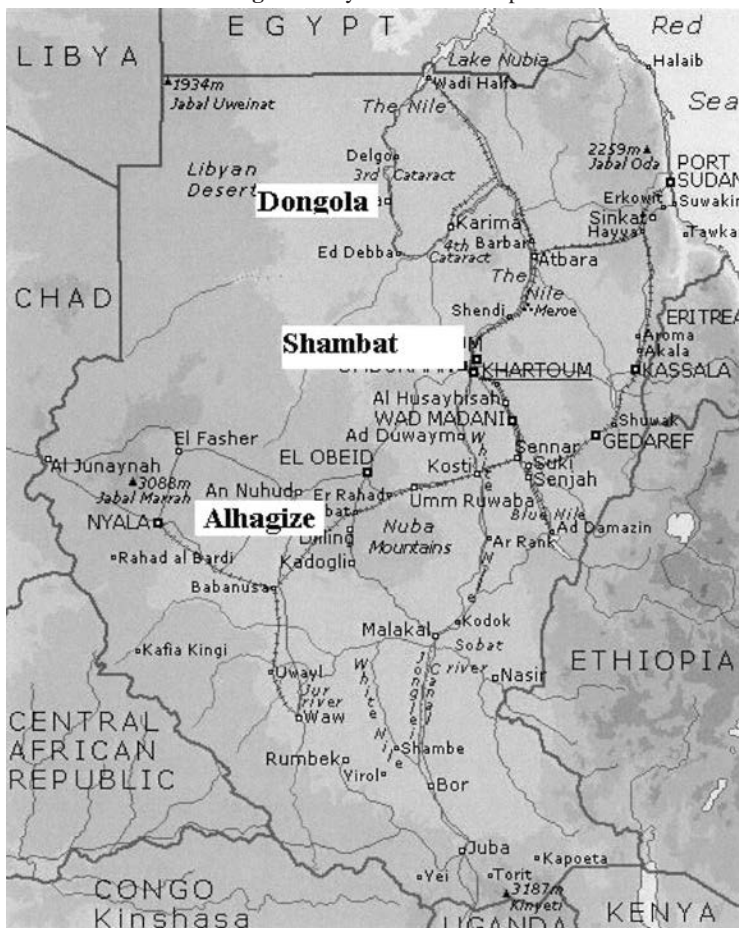

feeding practices, veterinary care of animals, draught animal selection and training. Special consideration was dedicated to explore the potential constraints faced by farmers in animal traction. This was carried out through observation and group discussions with farmers. Data were descriptively analyzed using the statistical package for social studies (SPSS) and differences between the three sites were tested using the chi square test.

Results and discussion

Types of Animals Used in Agriculture

All farmers in Shambat use oxen as traction animals for land preparation only. Animals are not used for transportation because of the availability of half trucks that are faster and cheaper. Further, animals are not used in crop threshing. This is justified by the type of crops produced, as Shambat farmers specialize in vegetables and fodders and do not produce cereals. In Dongola, the majority of farmers use animals in land preparation, transportation and threshing. Oxen are the only traction animals used for land preparation while donkeys and horses are used in transportation either as pack animals, or pulling carts. The tech-

nology is used successfully in the area to the extent that it is hired for higher rates compared to tractors when cultivating date palm orchards (high maneuverability and shallow ploughing that does not cut the roots of palm trees). Dominance of oxen as traction animals along the Nile valley relates to the heritage in the area as the technology resulting from centuries of cultural interaction with Upper Egypt where water buffaloes were used for centuries. Water buffaloes can not withstand the climatic conditions in the Sudan; hence they were replaced by oxen.

In contrast in Alhagize, the majority of the farmers use their animals in land preparation only and few use them in transportation and threshing (Fig. 2). Oxen and donkeys are used in land preparation, while only donkeys are used for transportation.

The technology has been recently introduced to the area and farmers' capacity building is still in progress. The value of traction animals increase when areas of usage diversify (FAO, 2000). Therefore, farmers in

Alhagize area seem to benefit less from their animals in comparison with Dongola. However, differences have shown to be significant between the three areas using the chi square test (P=0.05).

In the three areas oxen are harnessed in pairs using a locally made double shoulder yoke (Fig. 3). A rigid wooden or metal pole is used as a beam to connect the plough to the double shoulder yoke. In Shambat and Dongola where land leveling is essential, levelers are connected by ropes to the harness.

Animal Feeding Practices

Most of the farmers in Shambat and Dongola feed their animals the same forage type and amount as other animals (Fig. 4). Drought animals should be fed differently due to the additional burden placed on

Fig. 3 Double shoulder yoke



Fig. 2 Animal uses

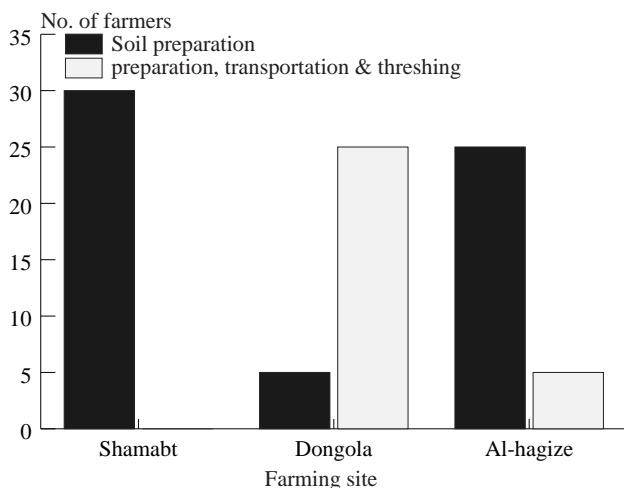
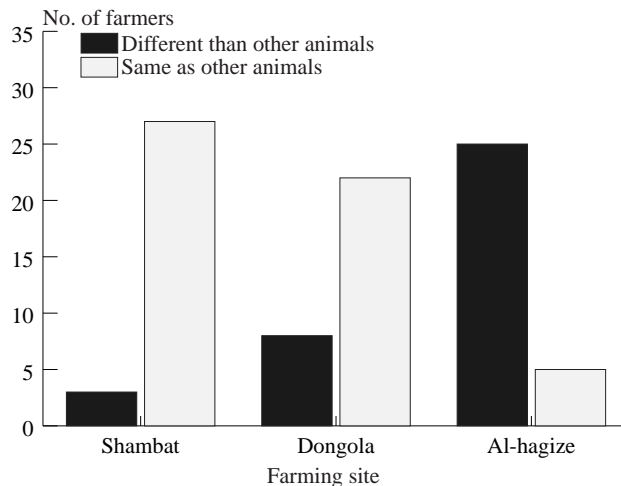

Fig. 4 Animal Feeding



their back as mentioned by (FAO, 1990). Apparently animals in Shambat and Dongola seem to be mis-fed, but farmers there produce legume forages and other type of green forages (“forage sorghum”), which, in addition to concentrates, keep animals in a very good nutritional state. Hence, no additional feed is needed. On the other hand, in Alhagize farmers depend on feeding animals on hay in the off season and grasses in the rainy season. Both have low nutritive value and, consequently, working animals need additional feeding. However, most of the farmers in Alhagize area follow the right decision by feeding their animals differently using concentrates. Farming system effect is evident in this regard (P-0.05).

Animal Selection

Being healthy and of a large size were the major criteria for most of Shambat farmers for animals selection (73 %). A minor portion of them (27 %) were interested more in animals age (Table 1). Both groups perceive animal health condition and good size as indicators of animal strength and ability to work. A comparatively similar trend was observed in Dongola (47 % pointed health and size and 13 % pointed age). A considerable portion of them (40 %) mentioned local breed as a

Table 1 Frequency distribution of farmers per animal selection criteria

Animal selection criterion	Shambat		Dongola		Al-Hagize	
	Frequency	%	Frequency	%	Frequency	%
Healthy & Large size	22	73	14	47	6	20
Age	8	27	4	13	4	13
Local breed	0	0	12	40	0	0
Good price + red color	0	0	0	0	20	67
Total	30	100	30	100	30	100

major criterion for animal selection. This is probably to avoid disease transmission from other areas and for traditional reasons. The characteristics mentioned by Shambat and Dongola farmers were almost absent in Alhagize area where farmers highlighted health, large size (20 %), price color of the animal (67 %) and age (13 %). Differences in this regard are cultural and influenced by the farming system. Further, some of these criteria are not supported by scientific facts. The recent introduction of the technology and the poor condition of Alhagize farmers suggest the need for intensive capacity building packages in animal traction. Similarity between Shambat and Dongola relate to the heritage and culture shared in common in the two sites besides the similarity between the two farming systems.

Animal Training

All farmers in Shambat train their animals on the farm, and almost 90 % in Dongola. But in Alhagize most of the farmers (77 %) train their animals off farm (Fig. 6). Training animals on the farm reduces the time and financial resource required for the training. The seasonality of production might have resulted in this. Farming systems in Alhagize are traditional rainfed where the season is limited to rainfall and farmers have to be prepared before the first rain shower to catch up with the season. Moreover, the off-season use of donkeys and horses as pack animals allows farmers to train animals off farm. Then training for traction purposes for agriculture becomes an easy task.

All the oxen in the three sites are trained on farm, while donkeys and horses are trained off-farm unless the conditions on-farm allow. For

Fig. 5 Animal training site

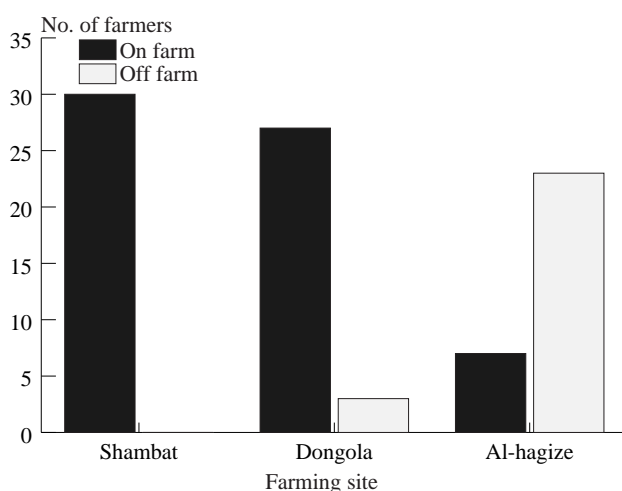

Fig. 6 Animal trainers

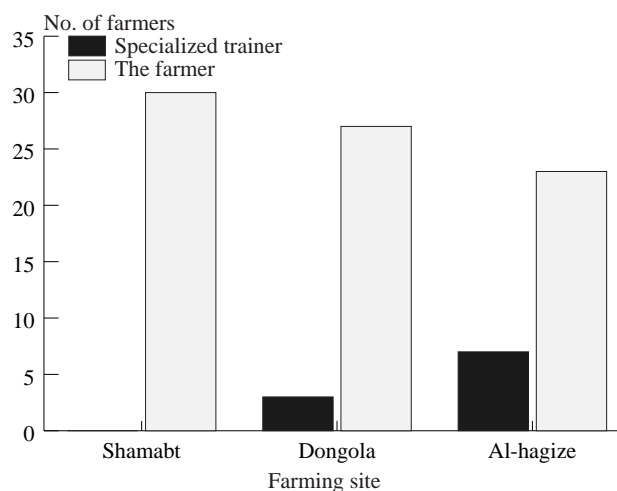

Table 2 Frequency distribution of farmers per animal working hours

Working hours	Shambat		Dongola		Al-Hagize	
	Frequency	%	Frequency	%	Frequency	%
1 to 5 hours	8	27	7	23	16	53
6 to 10 hours	18	60	23	77	14	47
> 10 hours	4	13	0	0	0	0
Total	30	100	30	100	30	100

Alhagize, training on the farm is not possible unless training sessions start at the beginning of the rainy season.

Farmers in Shambat train animals by themselves (Fig. 6). The situation is almost the same in Dongola; except for (5 %) who hire other experienced farmers to train their animals. In Alhagize area, slightly more than three fourths of the farmers (77 %) train animals by themselves. Though animal type is different in Alhagize where farmers manage to carry out animal training.

Animal traction in agriculture does not have a long history in the area, but animals were used as back animals. Hence, their training for agricultural work will not be so difficult, despite the general belief that “animal training is a matter of course in the areas with long history and tradition in animal traction”. However, no significant differences were indicated in this regard.

Fig. 7 shows that the majority of

Shambat farmers (70 %) take from 15 to 30 days to train their animals. A few of them (30 %) train animals in a period of one month to 45 days. Dongola and Alhagize recorded identical results with slightly less than three fourths (73 %) of them taking from 15 to 30 days for animal training. Despite the differences in animal types between Alhagize and Dongola, training took the same time. The difference in Shambat is probably due to animal age. Animals are comparatively older in Khartoum and are purchased from the market, while in Dongola they train “farm animal”. Results for Shambat were significantly different (P-0.05) compared with both Alhagize and Dongola, which recorded statistically similar training periods. This clearly reflects the effect of location on training period of draught animals (which from its side is affected by tradition, farming system and animal type).

Working Hours of Draught Animals

Work hours of draught animals reflect the intensity of operations with reference to farm size. Working hours in Shambat area ranged from 1 to 5 hours for less than one third of the farmers (27 %), while for the majority (60 %) ranged between 6 to 10 hours (Table 2). Few farmers work for more than 10 hours. In Dongola, more than three fourths of the farmers (77 %) work from 6 to 10 hours, while the rest work for 1 to 5 hours. Working hours are influenced either by plot size, or by the intensity of operations. Plot size effect is evident in Alhagize where the majority of the farmers (53 %) work for less than five hours. Further, farmers in Ahagize use draught animals in ploughing only, while in Shambat and Dongola animals are used for ploughing, leveling and ridging. Farming system had a significant effect on animals working time (P-0.05). In all the three sites working hours are divided into two shifts; one in the early morning and the other in the afternoon.

Veterinary Care of Draught Animals

Most of the farmers in Dongola and Alhagize (70 % and 90 %, respectively) have shown an outstanding response regarding veterinary care of draught animals as they take their animals regularly to the veteri-

Fig. 7 Animal training duration

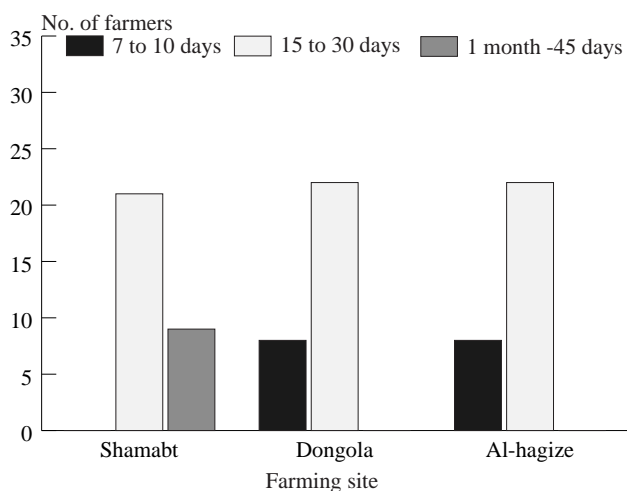
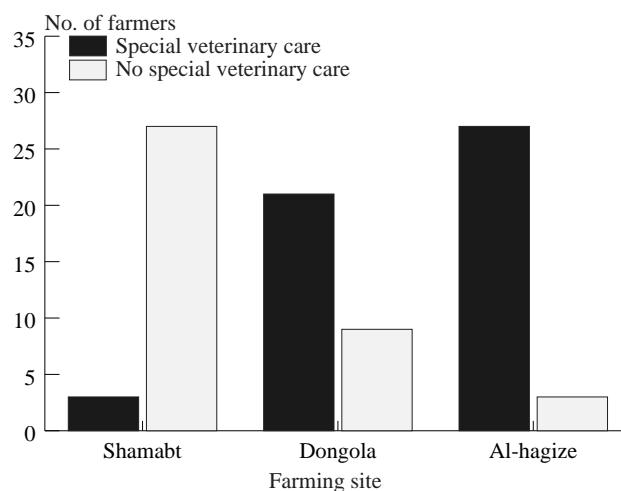

Fig. 8 Veterinary care of draught animals



nary centre (**Fig. 8**). This is the right decision as the main factor affecting the animal power output is its health condition and weight. In Shambat, most of the farmers do not access veterinary service, though the services situation is better in Khartoum. Instead farmers buy medicines directly from veterinary pharmacies. Dongola and Alhagize results were statistically similar while they were both different from Shambat ($P=0.05$) based on the chi square test. Veterinary care for animals is not common in Sudanese culture. Animals are not taken to the veterinary centre unless they are seriously sick, or during vaccination campaigns. The trend in Shambat and Dongola is alarming and draws attention to the serious problems animal traction can face.

Problems and Constraints Facing the Technology

Farmers in Shambat are faced by the problem of farming fees and animals license. Timeliness was mentioned by a few farmers in Shambat and Dongola. Problems of veterinary care, feeding, extension and training faced Alhagize farmers. It is obvious that farmers in Alhagize area faced more problems than Shambat and Dongola. Nevertheless, the farmers in the three areas have different views as to the most important constraints facing them. This is due to differences in farming systems, soil type and the

history of technology itself in each area.

Field observations revealed weak consideration from the Ministry of Agriculture to animal traction in agriculture at both federal and state levels. Animal traction farmers could not organize themselves into a union or society to represent their interests, nor did researchers and scholars establish an animal traction society or network to benefit farmers and boost the technology application in the country, unlike the neighbouring Ethiopia, Kenya and Uganda where there are active networks and societies.

Farmers face many problems with harnessing and implements repair and manufacture. This leads to reluctance from other farmers to adopt the technology from one side and to un-affordability of others to purchase the implements they need.

Conclusion

Animal traction in Sudanese agriculture showed several differences in regard to the farming system; mainly in animal types, feeding practices and farming operations. Relative similarities concentrated in animal harness, veterinary care, training and animal working hours. The technology is faced by many constraints and problems that are site specific.

REFERENCES

- Ajav, E. A. 2000. Animal traction as a source of power for agricultural development in Nigeria. <http://www.atenasa.org>.
- FAO. 1990. Agricultural Engineering in Development: Selection of Mechanization Input. FAO Agricultural Services Bulletin No. 84. Food and Agriculture Engineering in Development, of the United Nations. Rome Italy.
- FAO. 2000. Drought animal power. An overview. AGSE Report. Agriculture 2.1 spot light. <http://www.fao.org>.
- Fidiel, M. M. 1998. The Experience of in participatory development of donkey. Drawn plough in North Darfur, Western Sudan. www.iirr.org/PTD/cases/Majzoub.htm.
- Mohammed, S. E. 1982. Mechanization for modern and traditional agriculture in Sudan. Agriculture Mechanization in Asia, Africa and Latin America Vol. x111, No. (1) pp: 37-38.
- Mohamed, M. S. 2001. Production and Distribution of Animal Traction Implements in South Darfur State, Challenges in the 21st century. Agricultural Research Corporation (ARC) Nyala Station, Sudan.

■ ■

NEWS

You can download free PDF format files of AMA back issues dating back to 2-7 years.
Access our website.

<http://www.shin-norin.co.jp/ama/ama.html>

Design and Development of Hand Operated Maize Dehusker-Shellers for Farm Women

by
S. P. Singh
Senior Scientist (FMP),
DRWA Sub-centre (ICAR)
CIAE Campus,
Bhopal- 462 038, INDIA
singhsp65@gmail.com

Pratap Singh
Ex. Director of Research,
MPUAT
Udaipur- 313001, INDIA

Surendra Singh
Project Coordinator (FIM)
CIAE (ICAR)
Bhopal- 462 038, INDIA

Abstract

Maize is becoming the third major crop of the country after rice and wheat. Dehusking and shelling of the maize cob are done mostly by the farm women in the country. This operation is mostly performed by the traditional method. To provide options for small and hill farmers, a hand operated maize dehusker-sheller has been designed, developed, fabricated and evaluated. Farm women could easily operate the machine with right or left hand. The output capacity with the machine was about 60 kg/h at a feed rate of 80 kg un-dehusked cob per h. The dehusking efficiency was 100 %, shelling efficiency 98.8 % and grain breakage 0.3 % at a peripheral cylinder speed of 5.6 m s^{-1} . Two farm women (one for hand cranking and another for feeding the cob) were required during operation of the machine. Both the workers could be shifted during operation to increase the continuity in operation.

Introduction

Normally cobs are plucked from the standing maize crop and thereafter the maize stalk is harvested. After plucking the maize cob, it is dehusked manually and then dried in the sunshine to reduce moisture content to 15-21 percent (d.b.) for shelling to get the grain from the cob. The activity related to removal of the outer sheath from the plucked cob (called dehusking) is mostly performed by farm women. It is also observed that except beating with a stick, removal of grain from rest method (finger, sickle, etc.) is done by farm women (Singh, 2010). To mechanize this activity for small and hill farmers, the pedal-operated maize dehusker-sheller was developed at Udaipur (Mudgal *et al.*, 1998). This machine had a single octagonal cylinder, one half of which was provided with rasp-bars and the other with rubber strips to act as dehusking and shelling units respectively. This dehusker-

sheller was recommended for medium farms (Ali *et al.*, 1986) but this equipment could not reach to the farmers as this was operated by two men workers due to high power requirement. The dehusking and shelling efficiencies were 90 and 95 percent, respectively, at optimum moisture content of 17 to 19 percent. These were some of the reasons for not reaching to the farmer level. The estimate of population of agricultural workers indicated the declining trend of men workers and increasing trend of women workers for farm operations (Anonymous, 2006). Thus, an attempt was made to design, develop and fabricate a maize dehusker-sheller operated by farm women. The present paper discusses the design, development and evaluation of such a maize dehusker-sheller.

Methods and Materials

During the development of the

prototype of the maize dehusker-sheller, it was kept in mind that the equipment suitable for farm women would automatically suit to men workers as farm women were having less strength than men workers (Singh *et al.*, 2006). Farm women wear loose cloth (Saree) and are not accustomed with cycling. Thus, they prefer such equipment that can be operated by hand. The design criteria for development of different components of the hand operated maize dehusker-sheller are described below:

Threshing System

Of the cross-flow and axial flow threshing, the axial flow system was opted as material passed through the threshing zone between the axial flow cylinder and concave several times due to rearward movement in a helical path, rather than making a single pass in the cross-flow cylinder. This feature with the axial flow threshing system helps in getting more retention time for un-dehusked cobs during continuous feeding. This system consumes low energy because it does not make fine straw in comparison to spike tooth and rasp bar type threshers. Moreover, with the dehusker-sheller, there is no need of making straw so the axial flow system was opted.

Threshing Cylinder

The threshing cylinder consisted of beaters, solid lugs and louverers. Four beaters were used in the cylinder of the axial flow threshing system for providing sufficient space to avoid carrying of un-dehusked maize cobs though the periphery of the threshing cylinder. This also helped in reducing total power requirement in dehusking-shelling. The beater length of cylinder of the axial flow maize dehusker-sheller was 0.54 m including square solid plates.

Threshing Element

The rasp bar, spike tooth and solid lugs, square solid lugs were opted as threshing element on MS angle iron beater as it also helped in reducing

the energy requirement in the operation of dehusking-shelling the un-dehusked cobs due to less contact with cob. Based on minimum length of cob (75 mm), the number of solid lugs in each beater was three. The lug spacing on each beater was 150 mm, thus, during rotation, a lug spacing of 75 mm was obtained so that even the small cob having a length up to 75 mm could be dehusked and shelled with the machine. The size of each square solid lug was of 320 mm width × 320 mm height × 460 mm length and the lug was mounted on the parallel beaters at an angle of 25.760 clockwise and on remaining parallel beaters it was welded in anti-clock wise directions at the same angle.

Louverers

Two helical louverers (one at the feeding side and the other at the outlet side) were provided on the beater of the cylinder for easy movement of cobs from feeding end to outlet side. Both the louverers were made in arch shape and attached from first solid lug of a beater to the second lug of another beater. Simultaneously other louverer was welded from the second lug of the third beater to the third lug of the fourth beater.

Cylinder Diameter

The cylinder diameter, including lug height, was 380 mm to achieve the peripheral tip cylinder speed of about 5.5 m s⁻¹ at hand a cranking speed of 50 to 55 rpm. The large size diameter cylinder was taken as this worked better with available power. Using a cotter bolt, the cylinder was tightened with cylinder shaft.

Design of Cylinder Shaft

This was designed considering torsion combined with bending, assuming uniformly distributed load on a simple supporting beam. The following formula was used for calculating cylinder shaft diameter:

$$(\pi d^3 / 16) = [\sqrt{T^2 + (M^2 / S_{allow})}] \dots \dots \dots (1)$$

Where,

d = diameter of cylinder shaft,

cm

T = torque on shaft, kg-cm

M = bending moment on shaft, kg-cm

Sallow = allowable stress for mild steel shaft, 560 kg/cm²

Torque on cylinder shaft was calculated using following formula:

$$T = (HP \times 4500) / 2 \pi N \dots \dots \dots (2)$$

Where,

T = torque on shaft, kg-m

HP = horse power to be transmitted, hp

N = speed, rpm

$\pi = 3.14$

Assumption,

HP = Considering maximum power that could be developed by a human being of 1 hp, as reported by Wilkle (1960) and Anonymous (2010).

N = Shaft speed was taken 275 rpm to obtain peripheral speed of 5.5 m s⁻¹. Design torque was kept the same as obtained, i.e., 260.57 kg-cm as maximum power developed by a human being was considered. Bending moment was calculated assuming uniformly distributed load over a simply supported beam. Load was calculated on the basis of cob weight to be fed. Cob weight of 285 g was considered. Assuming a load of about two un-dehusked cobs (570 g weight), thus, 570 g load would be on cylinder. The length of circular MS shaft was 800 mm to accommodate the width of cylinder, cylinder cover, bearings and 100 mm excess shaft to provide the driven sprocket. Bending moment on the cylinder shaft was calculated by:

$$M = (W \times l) / 4 \dots \dots \dots (3)$$

Where,

M = bending moment on shaft, kg-m

W = load per metre length, kg/m

l = cylinder/ main shaft length, m

Putting the value of torque, bending moment and allowable shearing stress in formula 2, the diameter of the cylinder shaft was about 14 mm. Taking 2 as factor of safety, the di-

iameter became 28 mm.

Bottom concave of Cylinder

The concave clearance was decided as per the literature and the diameter of kernel (shelled cob) was also considered which varied from 16 to 37 mm. Hence, the concave clearance was kept to 35 mm. The hole size of mild steel mesh/sieve for lower concave was about 30-35 % more to the maximum length/diameter of maize grain (12 mm) so that grain obtained from the process of dehusking-shelling could easily pass through it. Thus, hole size of perforated concave screen was 16 mm. The diameter of concave perforated sheet was 430 mm with a depth of 185 mm. A collar of 65 mm width was also provided at both ends on length side so that the concave rested on the main frame. Six 8 mm square bars 540 mm long were welded over the perforated concave at equal spacing of 80 mm as this square member also helped in dehusking-shelling the un-dehusked maize cob.

Cylinder Cover

A cylindrical shaped cover was provided for the top portion of the cylinder. The diameter, length and depth of top cylinder cover were 525, 560 and 285 mm, respectively. A rectangular opening (45 mm width x 50 mm height) from both sides was provided for smooth running of cylinder shaft. A square opening of 120 mm was provided on this cover from the front side to mount the hopper. The top cover was welded at three places using a hinge clamp from the back side and, at the front side, three lock clamps were attached so that it could be easily opened whenever required. To provide stability to top cover while in opening position, a stopper was welded on second hinge clamp at the back side.

A conical shaped cover was provided for the bottom of the cylinder, which covers concave bottom sieve and also facilitates the grain coming from the cylinder. The diameter,

length and height of conical shaped bottom cover were 525, 560 and 300 mm, respectively. An opening on the bottom cover from the other end of feeding was provided in half arch shaped above 12 mm from perforated concave for coming out dehusked material from the cylinder. The opening for husk outlet was decided based on 10 % of average size of un-dehusked cob with stalk (237.6 mm).

Feeding Arrangement

The feeding arrangement of the dehusker-sheller was the 'throw-in' type, where whole cobs were fed into the machine through a hopper. The feed hopper was designed for feeding one by one cob to avoid over feeding which might affect the performance of the machine due to limited available power from women workers. The height of the hopper was 330 mm to reduce the energy requirement in dehusking-shelling maize cobs (Johnson *et al.*, 1969). The hopper height from ground was 1,400 mm.

Grain Collecting System

A trapezium shaped grain collecting system was made and attached with the opening provided in bottom cover for grain after dehusking-shelling. A hook on both side of the grain collection point was welded to mount a sack on the vertical collar. The height from ground of this unit at the grain collection point was 400 mm. This unit was mounted at an angle of 250 from horizontal to allow free flow of maize grain.

Frame of Dehusker-sheller

Trapezium shaped frame was provided for the maize dehusker-sheller to provide more stability during operation. An angle of 6.610 from top breadth was, thus, provided at each leg. A small wheel (120 mm diameter solid wheel) at four corners of the frame was provided to facilitate the machine for easy movement from one place to another place. The handle height of the machine was 600 mm. A wooden handle grip 30 mm diameter and 140 mm long was provided.

Power Transmission System

To transfer of power from a human being to the machine, a chain sprocket system was selected for transmission of power to a parallel shaft; i.e., from cranking end to cylinder shaft with moderate centre distance. It consisted of chain, sprockets, frame for mounting drive sprocket, shaft for mounting drive sprocket, handle and chain cover. Selection of the chain-sprocket system was based on following criteria:

- Maximum power developed by human being= 1 hp
- Speed of drive sprocket = 50 rpm
- Required cylinder tip speed = 5.5 m s⁻¹
- Dehusking-shelling cylinder diameter = 380 mm

The shaft speed of cylinder was calculated using formula,

$$\text{Shaft speed (m s}^{-1}\text{)} = (\pi D N) / 60. \dots\dots\dots(4)$$

Where,

D = diameter, m

N = speed, rpm

Thus N became 277 rpm.

Let us take the rpm of driven sprocket = 275.

$$\text{The required velocity ratio} = (\text{Shaft speed, rpm}) / (\text{Cranking speed, rpm}) \dots\dots\dots(5)$$

The required velocity ratio = 5.5

As per the availability, the number of teeth on the small sprocket (n₂) was 13. Therefore, the number of teeth on the larger sprocket (n₁) at the cranking end was 68.

The Driving Force was Calculated using the Formula

$$F = (HP \times 4500) / V \dots\dots\dots(6)$$

V can be calculated by using formula,

$$V = (P N_1 n_1) / 1000 \dots\dots\dots(7)$$

Where,

F = driving force, kg

V = chain velocity, m/min

p = chain pitch, mm

N₁ = rpm of drive sprocket

n₁ = number of teeth on drive sprocket

A small chain pitch of 12.5 mm was selected as it is usually desir-

able in chain drive to reduce surging of the chain. Centre distance between drive and driven sprockets was calculated based on 40 pitch of sprocket, i.e. 500 mm.

For finding single/duplex/triplex chain, the formula used was,

$$Fu = \text{Factor of safety} \times F \dots\dots (8)$$

Factor of safety = 8.2 as recommended

$$Fu = 868.216 \text{ kg}$$

Single chain was found due to breaking load of 1417 kg.

Actual factor of safety was checked by

$$[n] = Q / \Sigma P \dots\dots\dots (9)$$

Where,

Fu = breaking load, kg

Q = breaking load of chain, kg

[n] = actual factor of safety

Taking the breaking load of chain (Q) = 1417 kg and considering actual factor of safety [n] that should be greater than allowable.

$$\Sigma P = P_t + P_c + P_s$$

Where,

$$P_t = (75 \times H \cdot P) / V = 105.63 \text{ kg} \dots\dots\dots (10)$$

$$P_c = w v^2 / g = 0.031 \text{ kgf} \dots\dots\dots (11)$$

$$P_s = K w a = 1.2 \dots\dots\dots (12)$$

Where,

P_t = tangential force due to power transmission, kgf

P_c = centrifugal tension, kgf

P_s = tension due to sagging of chain, kgf

V = chain velocity, m/s

g = gravitational acceleration, 9.81 m/s²

K = coefficient for sag

w = weight per metre of chain, kg

a = centre distance, m

Thus,

$$\Sigma P = 106.861 \text{ kgf}$$

Hence,

$$[n] = Q / \Sigma P = 1417 / 106.861 = 13.26$$

Thus, the design was safe.

Design for diameter of shaft to mount drive sprocket was done considering torque only. The formula used for calculating the diameter of shaft was:

$$D^3 = (16 \times T) / (\pi \times fs) \dots\dots\dots (13)$$

Where,

fs = allowable stress for mild steel shaft, 560 kg/cm²

Torque on drive sprocket shaft was calculated using equation,

$$HP = [2 \times \pi \times \text{Speed of rotation (rpm)} \times \text{Torque (kg-m)}] / 4500 \dots\dots\dots (14)$$

Assumption,

Horse power (HP) to be transmitted = 1 hp

rpm of hand cranking shaft (N) = 50

Thus,

$$T = 14.324 \text{ kg-m} = 1,432.4 \text{ kg-cm}$$

Design torque was kept the same as obtained, i.e., 1,432.4 kg-cm as maximum power developed by a human being was considered.

Hence, D = 2.35 cm = Say 25 mm

Diameter of shaft of drive sprocket was taken as 25 mm. A safety cover was provided for the chain-sprocket to avoid any accident. Assuming power loss of 5 % due to power transmission through chain-sprocket and 10 % loss in stepping up speed, the net power would be 85 % of maximum available power from human being that could be utilized for operating the maize dehusker-sheller.

Performance of machine

The cylinder (540 mm length) was fitted in the first prototype of hand operated maize-dehusker-sheller. This prototype could accommodate a cylinder of 725 mm length. The prototype fitted with 540 mm cylinder was assessed and farm women could successfully operated the machine. This machine was able to perform the intended function. Thereafter, the prototype of hand operated maize dehusker-sheller was operated by ten farm women in standing posture for dehusking-shelling the un-dehusked maize cobs (Fig. 1). The average moisture content of grain was measured using standard techniques of the oven drying method. The performance of the machine was observed in reference to dehusking, shelling and grain breakage. Feeding of cob was one by one and feeding of next cob

Fig. 1 Farm woman operating the 1st prototype of hand operated maize dehusker-sheller



Fig. 2 Grain obtained (recovery) from maize cob at different feed rates while operating maize dehusker-sheller with farm women

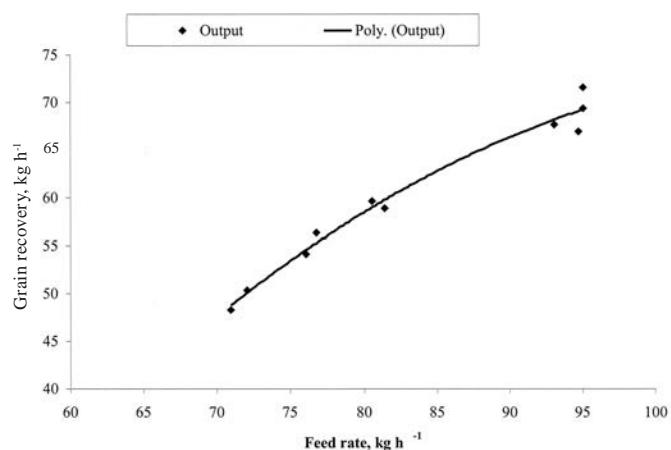

was based on slow release of grain from the grain outlet. Output of the dehusker-sheller was calculated. Grain obtained from maize cob at different feed rates while operating the maize dehusker-sheller with farm women is shown in **Fig. 2**. Shelling efficiency and grain breakage at different cylinder speeds while operating the maize dehusker-sheller with farm women are shown in **Fig. 3**.

Based on the results obtained with this prototype, a computer aided design was prepared for fabrication of the final prototype of the hand operated maize dehusker-sheller. The final machine consisted of trapezium shaped frame, threshing cylinder (540 mm length \times 380 mm diameter) with solid lugs and helical louvers, hopper, power transmission unit, transport wheels (75 mm diameter and 30 mm width), etc. The orthogonal view of the machine is shown in **Fig. 4**. This machine was fabricated as per design. The machine was also evaluated with farm women (**Fig. 5**) to assess its performance in comparison to earlier prototype. The data obtained from the first prototype was compared with final prototype and are given in **Table 1**. The manufacturing cost of the final prototype of hand operated maize dehusker-sheller is given in **Table 2**. The cost of operation of

Fig. 4 Orthogonal view of final prototype of hand operated maize dehusker-sheller

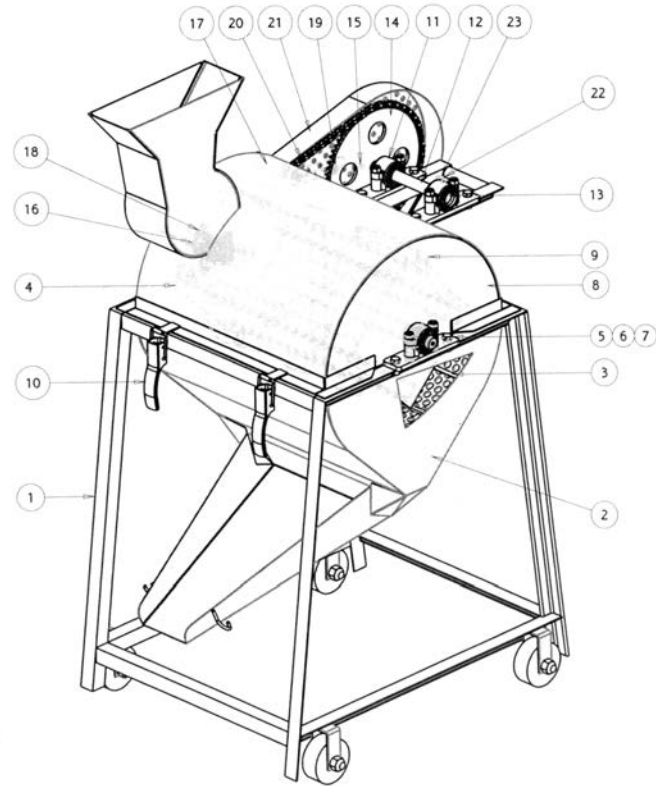

- | | | | | | |
|---|------------------------|----|--------------------------|----|-----------------------|
| 1 | Trapezium shaped frame | 9 | Stopper on hinge clamp | 17 | Handle assembly |
| 2 | Bottom cylinder cover | 10 | Latch assembly | 18 | Bolt |
| 3 | Sieve | 11 | Bearing block | 19 | Nut |
| 4 | Threshing cylinder | 12 | Drive sprocket | 20 | Roller chain assembly |
| 5 | Bolt | 13 | Circular clip | 21 | Safety cover assembly |
| 6 | Washer | 14 | Drive sprocket assembly | 22 | Bolt |
| 7 | Nut | 15 | Key | 23 | Nut |
| 8 | Top cylinder cover | 16 | Driven sprocket assembly | | |

Fig. 5 Farm woman operating the final prototype of hand operated maize dehusker-sheller



Fig. 3 Shelling efficiency and grain breakage at different cylinder speed while operating maize dehusker-sheller with farm women

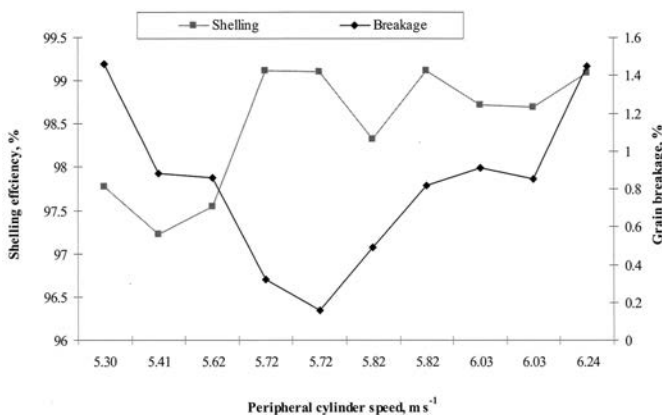

maize dehusker-sheller per kg grain was calculated and given in **Table 3**.

Results and Discussion

Effect of Feed Rate on Grain Recovery

The developed maize dehusker-sheller was evaluated by recording the performance of the machine during hand cranking by farm women. The grain moisture content was 11.7 + 1.16 % (d.b.). The grain recovery increased from 48 to 72 kg/h with increase in feed rates from 71 to 95 kg/h at hand cranking speed from 51 to 60 rpm with the developed machine (**Fig. 2**). The variation in grain recovery might be due to cylinder speed and grain to spent cob ratio. The relationship between grain obtained (recovery) from the un-dehusked maize cob during different feed rates while operating the maize dehusker-sheller by farm women was established using linear, logarithmic, power, exponential and polynomial trends. The higher value of coefficient of determinant (R^2) suggested a second order polynomial trend. The polynomial trend clearly indicated at a feed rate of 95 kg/h, the declination in grain recovery was observed, which suggested stricting the feed rate for this machine to below 95 kg/h. The polynomial best fit equation is given in equation 15.

$$y = -0.0144x^2 + 3.2407x - 108.53 \dots\dots\dots(15)$$

The dehusking efficiency was 100 % at all the cylinder speeds. The relationship between peripheral cylinder speed and shelling efficiency and grain breakage is shown in **Fig. 3**. The shelling efficiency was increased from 97 to 99 % with increase in peripheral speed from 5.30 to 6.24 m s⁻¹ for the feed rates of 71 to 95 kg/h. The grain breakage was found lowest at speed of 5.7 m s⁻¹. The high grain breakage was observed at speed of 5.3 and 6.24 m s⁻¹. This might have been due to varia-

tion between impulse forces with respect to cob during dehusking-shelling process at corresponding cylinder lengths. The graph indicated the peripheral cylinder speed of 5.7 m s⁻¹ for optimum shelling efficiency with low grain breakage at a feed rate of about 80 kg h⁻¹.

Comparative Performance of Prototypes

None of un-dehusked maize cob came without dehusking with outlet in both prototypes, thus, the dehu-

sking efficiency was 100 % (**Table 1**). The shelling efficiency was 98.5 % at cylinder speed of 5.7 m s⁻¹ and grain moisture content of 11.2 % with prototype-I. While it was 98.8 % with the final prototype at cylinder a speed of 5.6 m s⁻¹ and grain moisture content of 10.1 %. Though, there was not much difference in shelling efficiency with both prototypes. It could be assessed that dried un-dehusked maize cob might gave better shelling. The output in terms of grain per kg with both prototypes

Table 1 Comparative performance results of prototype-I and final prototype while operating maize dehusker-sheller with farm women

Particulars	Average Values	
	Prototype-I	Final prototype
Maize grain/spent cob ratio	0.76	
Grain moisture content, % (d.b.)	11.7	10.1 + 0.22
Peripheral cylinder tip speed, m/s	5.7	5.6
Feed rate, kg/h	83.6	79.8
Output, kg/h	60.3	60.0
Dehusking efficiency, %	100	100
Shelling efficiency, %	98.5	98.8
Grain breakage, %	0.8	0.3

Table 2 Manufacturing cost of final prototype of hand operated maize dehusker-sheller

Parts	Weight, kg	Approximately cost, Rs.	
		Rate	Material cost
Trapezium shaped frame including frame of power transmission unit, kg	19.5	40/kg	780
Cylinder (beaters, lugs and square plate), kg	20.5	60/kg	1,230
Cylinder shaft, kg	3.3	50/kg	165
Top cylinder cover including hopper, kg	10.5	60/kg	630
Perforated concave including MS bar, kg	6.2	90/kg	558
Bottom conical shaped cover, kg	8.25	60/kg	495
Grain collection unit, kg	3.5	60/kg	210
Weight of handle, kg	1.5	60/kg	90
Sprockets, kg	1.6	16/teeth	1,296
Bearing cover with bearing, kg (4 nos.)	5.7	450/ unit	1,800
Weight of chain, kg	0.986	200/ chain	200
Safety cover, kg	1.201	70/kg	84
Transport wheel 4 no.		50/ piece	200
Nut and bolts			100
Paint (primer 1 l + paint 2l)		600	
Total cost of material (A)			8,438 (say 8,450)
Manufacturing cost including labour and overhead charges		50 % of A	4,225
Profit		20 % of A	1,690
Total manufacturing cost			14,365 (say 14,500)

was about 60 kg. The performance results of prototype-I and final prototype were almost identical.

All the farm women operated the equipment comfortably with either left or right hands. Two farm women (one for hand cranking and another for feeding the cob) were required during operation of the maize dehusker-sheller. Both the workers could be shifted during operation to increase the continuity in operation.

Weight of the final prototype of the hand operated maize dehusker-sheller was 85 kg. Four small transporting wheels 75 mm diameter were provided for ease in transport. Cost of fabricating (manufacturing) the final prototype came to Rs.14,500/ (290 \$), **Table 2**. The cost of getting one kg maize grain with hand operated maize dehusker-sheller came to Rs.1.15 (**Table 3**). The final machine was also used for shelling dehusked maize cob and it was found that the machine is ca-

pable of doing the desired job.

Conclusions

A hand operated axial flow maize dehusker-sheller operated by farm women was designed and developed. Farm women could easily operate the machine with right or left hand. The peripheral cylinder tip speed of 5.6 to 5.7 m s⁻¹ was found optimum from the grain breakage point of view. The output capacity with the machine was about 60 kg/h at feed rate of 80 kg un-dehusked cob/h. The dehusking efficiency was 100 %, shelling efficiency 98.85 % and grain breakage 0.3 % at 5.6 m s⁻¹ cylinder speed.

REFERENCES

Ali, U., J. Singh, A. K. Soni, and A. K. Maheshwari. 1986. Economic

and technical feasibility of maize dehusking and shelling. *Journal of Agricultural Engineering (ISAE)*, 23(1): 71-81.

Anonymous. 2006. Population Projections for India and States 2001-06. Report of the Technical Group on Population Projections Constituted by the National Commission on Population, Government of India, New Delhi (In Project Coordinator's, Tech. Report No. CIAE/ESA/2007/346, CIAE, Bhopal).

Anonymous. 2010. Horsepower-Wikipedia, the free encyclopedia. <http://en.wikipedia.org/wiki/Horsepower> (accessed 01.02.2010).

Bosoi, E. S., O. V. Verniaev, I. I. Smirnov, and E. G. Sultan-Shakh. 1990. Theory, Construction and Calculations of Agricultural Machines (Volume Two). Oxonian Press Private Limited, New Delhi, 469-494p.

Johnson, W. E., M. L. Jain, M. Y. Hamdy, and F. P. Graham. 1969. Characteristics and analysis of corn ear failure. *Transaction of ASAE*, 12(6): 845-848.

Mudgal, V D., N. K. Jain, J. S. Bordia, and P. Seth. 1998. Research digest: AICRP on Post Harvest Technology (1992-97) Udaipur Centre. CTAE, MPUAT, Udaipur, 26-32p.

Singh, S. P. 2010. Ergonomical Interventions in Developing Hand Operated maize dehusker-sheller for Farm Women. Un-published Ph. D Agricultural Engineering (FMPE) Thesis. CTAE, MPUAT, Udaipur.

Singh, S. P., L. P. Gite, and N. Agarwal. 2006. Improved farm tools and equipment for women workers for increased productivity and reduced drudgery. *Gender, Technology and Development*, 10(2): 229-244.

Winkle, D. R. 1960. Man as a source of mechanical power. *Ergonomics*, 3(1): 1-8.

Table 3 Cost of dehusking-shelling per kg maize grain with hand operated maize dehusker-sheller

Particulars	Values
Price of machine (P), Rs.	14,500
Number of labour employed	2
Output of machine, kg/h	60
Annual use of maize dehusker-sheller, h	200
Life of maize dehusker-sheller (L), yr	10
Salvage value (S), %	10
Interest rate (i), %	10
Labour charge, Rs. /h	17
A. Fixed cost	
	Formula
Depreciation cost using straight line method, Rs. / annum	$(P - S) / L$
Interest on investment, Rs. / yr	$[(P + S) / L] \times (i / 100)$
Insurance and shelter, Rs. / annum	2 % of P
Total fixed cost (TFC), Rs. / annum	2,592.5
Fixed cost (FC) / h, Rs.	TFC/ annual use
	12.96
B. Variable cost	
Repair and maintenance costs, Rs. / annum	30 % of cost of maize dehusker-sheller
	4,350.0
Workers charge, Rs. / annum	No. \times h \times charge
	6,800.0
Total variable cost (TVC) / annum, Rs.	11,150.0
Variable cost (VC) / h, Rs.	TVC/ annual use
	55.75
Total cost of operation (TCO) / h, Rs.	FC + VC
	68.71
Operational cost/ kg grain, Rs.	TCO/Output
	1.15

■ ■

Evaluating the Performance of a Bulk-Milk Cooler on a Dairy Farm

M. A. Basiouny
Agricultural Engineering Research Institute (AEnRI),
Giza,
EGYPT



by
Said Elshahat Abdallah
Agricultural Engineering Department,
Faculty of Agriculture,
Kafrelsheikh University,
Kafr Elsheikh 33516,
EGYPT
dr.saidelshahat@yahoo.com

Abstract

The present study was carried out at the Animal Production Research Station, Sakha Village, Kafr Elsheikh Governorate, Egypt during the summer 2006 using a bulk-milk cooler. The principal objective was to calibrate the bulk-milk cooler at different milk loading capacities (collection every other day) and to assess the applicability of those capacities in accordance with the cooling capacity standards of bulk coolers. At the first milk loading for every day collection (50 % of cooler capacity), milk temperature reached 277.3 K within two hours from starting the storage time. The first loading for every day milk collection was successfully accorded with the cooling capacity standards. Conversely, the specifications of the bulk-milk cooler at the second milk loading for every day collection were not achieved and not in accordance with the cooling capacity standards. Milk temperature reached 286.8 K at the end of the second loading when it must not exceed 283 K. On the other hand, at the first loading for every other day milk collection experiments, milk temperature reached 277.4 K after only 0.5 h from the beginning of storage time. This was essentially

due to the small capacity of milk (25 % from cooler capacity). At the end of the second milk loading, for every other day milk collection, milk temperature was 281.9 K and was accorded with the cooling capacity standards. For every day milk collection, cooling capacity of the bulk cooler was increased during the second loading (100 % of cooler capacity) by 17.51 % over that of the first one (50 % of cooler capacity). Conversely, for every other day milk collection, cooling capacity was reduced during the second loading (50 % of cooler capacity) by 14.77 % over that of the first one (25 % of cooler capacity). For determining the convenient capacity of the bulk-milk cooler for every day milk collection, the bulk milk cooler capacity should not exceed 80.38 % (1.286 m³) of milk to maintain milk temperature at the recommended level for safe storage and marketing.

Introduction

Nowadays, it is important to consider the temperature of milk after milking process. If the milk is exposed to high temperature for several hours, it will have bacteria reproduction.

Milk should be stored at lower

temperature to prevent bacteria reproduction and follow the permissible limits of bacteria content. Good milk cooling machinery is needed for keeping the milk at low temperature; one of which is the bulk cooler. Today, most milk is cooled and stored on dairy farms in bulk-milk coolers. But bulk-milk coolers should pass the cooling capacity standards, which include the following two points: 1. When milk is collected every day, the cooling capacity standards are; (a) the bulk-milk coolers are designed for every day pickup and must cool 50 % (first loading) of the tank volume from 305 K (average temperature at which milk reaches the bulk tank) to ≤ 283 K within one hour, and to ≤ 277.4 K within the second hour from the storage time of milk. (b) When additional warm milk is added (second loading and full tank), mixed temperature of warm milk with cold milk should not exceed 283 K; 2. When milk is collected every other day, the cooling capacity standards of bulk-milk coolers are; (a) the coolers must cool 25 % (first loading) of the tank volume from 305 K (average temperature at which milk reaches the bulk tank) to ≤ 283 K within one hour, and to ≤ 277.4 K within the second hour from the storage time of milk.

When additional warm milk is added (second loading and 50 % of the tank volume), mixed temperature of warm milk with cold milk should not exceed 283 K. These standards apply to tanks (bulk-milk coolers) having the 3A label, which symbolizes approval by the three agencies involved in manufacture, use and inspection of farm bulk tanks, namely, the Dairy Industry Committee, the International Association of Milk, Food and Environmental Sanitarians and the Federal Drug Administration (Judkins and Keener, 1960; Campbell and Marshall, 1975; Sainsbury and Sainsbury, 1982 and Maton *et al.*, 1985). In Egypt, the quantity of raw milk is of about 5.32 Tg and its production rate is of 30.22 %. The annual consumption from milk products is of about 50.2 kg/person per year. Egypt imports, every year, 55 Gg from milk products. Therefore, the rate of self-sufficiency from milk products is of 92.22 % (CIHEAM, 2006). The specific heat (heat capacity) of the whole buffalo milk varies widely, depending upon the temperature. The usual range is from 3.894 to 3.940 kJ/kg.K. The specific heat is greatest at 292.4 K, and decreases rapidly above and below this point. An average figure may be taken as 3.940 kJ/kg.K. The specific gravity of whole milk also varies according to its composition. The usual range is from 1.028 to 1.035. Note. Also, that the specific gravity changes very widely with the temperature so that, in practice, all readings must be made at a certain temperature; usually 288.5 K or a correction must be applied. An average figure may be taken as 1.032 (Farrall, 1963). There are two types of refrigerated farm bulk tanks: the direct cooling or direct expansion type of tank and the indirect cooling or the ice building chilled water bulk tank. The time required for cooling milk is less with the indirect cooling tank than with the direct one. The ice-bank allows an immediate cooling,

while, in the direct expansion system, the condensing unit only starts to function at the beginning of the milking and, further, only works now for maintaining the milk at a temperature below 278 K during storage (Maton *et al.*, 1985). Bulk-milk coolers have been calibrated to facilitate in determining the amount of milk present. Proper sanitation and maintenance of milking equipment are important adjuncts to healthy cows, efficient production of milk and providing tasty and high-quality milk for man (Campbell and Marshall, 1975). The production of high-quality milk requires that it must be cooled promptly after milking and stored at a temperature low enough to inhibit the growth of bacteria (about 277.4 K). The practice has been to store the milk in cans having a capacity of 0.030-0.038 m³, which are placed in an insulated tank filled to the neck of the cans with refrigerated water. However, this is being replaced with bulk-milk tanks, which permit better handling and transporting milk easily to the market. The size of a milk cooling tank should be about of 1.5 times the annual average production per day (Barre *et al.*, 1988). Common practice in developed countries is to store milk on the farm for 1-3 days at low temperatures (277-279 K) in order to reduce collection costs. Cold storage improves the bacteriological quality (Raynal and Remeuf, 2000).

The present investigation was conducted to evaluate the performance of a bulk-milk cooler on a dairy farm under the conditions of different milk loading capacities (every day and every other day collection). The specific objectives were drawn as follows:

- a) To distinguish between the behavior of every day and every other day collection and maintaining milk temperature inside the bulk cooler,
- b) To assess the applicability of the bulk-milk cooler in accordance

with the cooling capacity standards,

- c) To calculate the cooling capacity of a bulk-milk cooler when it is loaded at different capacities and
- d) To experimentally estimate the convenient volume of milk inside the bulk cooler.

Materials and Methods

The experimental unit was tested and calibrated in accordance with the cooling capacity standards under different milk loading capacities. The experimental work was mainly directed to investigate the influence of milk volume inside the cooling tank and the temperature and cooling capacity of the bulk cooler for both every day and every other day milk collection experiments.

Experimental Unit (Bulk-Milk Cooler):

The bulk-milk cooler was located in a special room, namely milkroom, which was beside the electronic milking system where milk was cooled after the milking process. Inside the electronic milker, there were four milking units. After finishing the milking process, the milk was expelled from the electronic milker to the bulk cooler and pushed it in the form of successive ones by means of a special pump and a group of pipelines. The bulk-milk cooler consisted of three principal components: milk cooling tank, refrigeration unit and milk discharge (emptying) pump. The internal, external and cover of the cooling tank were made of stainless steel. To avoid the heat dissipation through the cooling tank, there was insulated material between internal and external surfaces. The cooling tank was supplied with an agitator for maintaining the physical characteristics of milk during the cooling process. The milk cooling tank was provided with a volumetric meter to measure the milk volume

expressed in liters. Also, there was a specific system for controlling and measuring milk temperature in terms of centigrade degrees. This system contained a thermostat and digital thermometer (Model: WS-TE92). The cooling unit has direct refrigeration for the milk cooling tank. With the direct refrigeration type, the evaporator was installed at the bottom and in part of the sides of the cooling tank. In this way the milk came in direct contact with the evaporator and direct heat transfer was created from the milk to the cold source. The unique function of the emptying pump was to deliver milk from the bulk cooler to the collection vehicle with the purpose of marketing. The technical specifications of bulk-milk cooler are listed in **Table 1**. A geometrical drawing of it is depicted in **Fig. 1**.

Experimental Design:

Tests were divided into two main groups of experiments: the first group of experiments was concerned with studying the behavior of the bulk-milk cooler when it was implemented under every day milk collection. The every day collection experiments were classified into two different loading capacities. The first milk loading of the bulk-milk cooler was achieved when it

was loaded to 50 % of its capacity. The second milk loading was accomplished when it was loaded to 100 % of its capacity (full tank). The second group of experiments was involved to investigate the cooling behavior of milk under every other day collection conditions. In the same way, the every other day collection experiments were classified into the first and second milk loading of the bulk cooler. The bulk-milk cooler was loaded to 25 and 50 % of its capacity to indicate both the first and second milk loading, respectively. The obtained experimental results of every day and every other day collection were compared with the cooling capacity standards. The convenient capacity of the bulk-milk cooler was estimated. Also, the cooling capacity of the bulk-milk cooler was calculated at different milk loading capacities.

The Technique:

The investigation comprised two essential systems; namely, every day and every other day collection

of milk for the bulk cooler. The technique used for cooling milk was done as follows:

1. Air temperature of the milkroom space was measured and the mean value was of 304.42 ± 275 K.
2. Before loading milk into bulk cooler, air temperature of the cooling tank was recorded for every day and every other day milk collection experiments.
3. At the first milk loading to the bulk cooler, the following successive steps were done:
 - a) After bringing the first quantity of milk to bulk cooler, refrigeration was turned on automatically and agitator was started and kept going until milking was completed and milk cooled to at least 277.4 K.
 - b) Quantities of milk were withdrawn from the electronic milking system to the bulk cooler every 0.1 h. Milk volume was 0.044 m^3 and 0.022 m^3 for every day and every other day milk collection experiments, respectively.

Table 1 Technical specifications of the used bulk-milk cooler

Indices	Model and value
Type	Direct refrigeration (DX/OC)
Cooling tank capacity	1,600 liters (1.6 m ³)
Cooling tank No.	AD-2002 + 50610
Condensing unit type	PRB/1/H8/521A
Refrigerant	R404
Charge	2.5 kg
Electrical input	200kW-3p (400V-50Hz)
Designer	The Netherlands
Manufacturer	Poland
Manufacture year	2000 AD

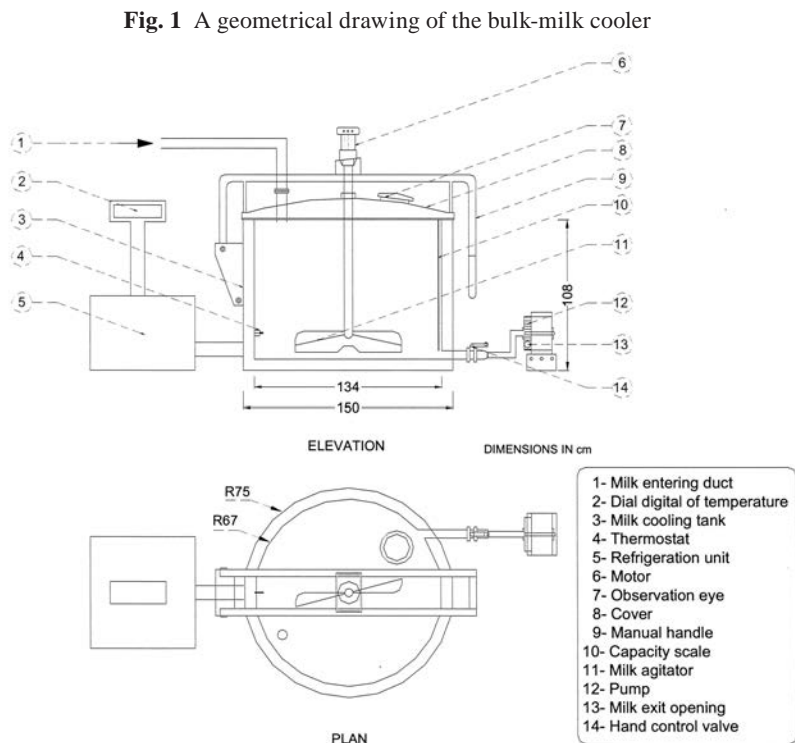

- c) Total milk loadings into the cooling tank, within loading time, was eighteen for filling the bulk-milk cooler to 50 % of capacity for every day milk collection. For every other day, the bulk-milk cooler was filled to 25 % of its capacity.
- d) Milk temperature was measured every 0.1 h throughout loading and storage time of the cooling tank, i.e., from the beginning of loading milk to bulk cooler until milk was inside the cooling tank and the temperature for safe storage had reached 277.4 K.
4. At the second milk loading of the bulk cooler, the steps which were followed during the operation of bulk-milk cooler at first milk loading were repeated. But at the end of milk loading, the bulk cooler was filled to approximately 100 and 50 % of its capacity for every day and every other day milk collection experiments, respectively.

Measurements:

1. A volumetric meter was used to measure milk volume inside the bulk-milk cooler in liters that could be easily converted to cubic meters. Milk temperature was measured by using a digital thermometer that gave temperature in centigrade degrees that could be converted to absolute Kelvin.
2. For accounting of the suitable and safe milk volume inside bulk-milk cooler at the second loading (100 %) for every day milk collection, the Arithmetic Interpolation Method was used to fulfill the task.
3. Cooling capacity of the bulk-milk cooler was determined by the following formula:

$$CC = [V \times \rho \times C_p (T_1 - T_2)] / t \dots\dots\dots (1)$$

where;

- CC: cooling capacity of bulk-milk cooler, kJ/h;
- V: milk volume inside bulk-milk cooler, m³;

- ρ : milk density (1,032), kg/m³;
- C_p : milk specific heat (3.940), kJ/kg.K;
- T_1 : milk temperature at any loading time, K;
- T_2 : milk temperature at the time which gives the temperature of safe storage (277.4), K and
- t : cooling hours or the time through which temperature of milk reaches T_2 , h.

Finally, concerning the statistical procedures, a multiple regression analysis was made to represent the data in linear form. Every developed equation was limited to the range of application. The relationship between cooling capacity of the bulk-milk cooler as a dependent variable and milk volume, milk temperature and milk loading time as indepen-

dent variables was developed for every day and every other day milk collection conditions.

Results and Discussion

Every Day Milk Collection Experiments:

For the first milk loading, the bulk cooler was loaded to 50 % capacity, as outlined in Fig. 2 and listed in Table 2. The volume and temperature with the loading and storage time is depicted in Fig. 2. At the initiation of the milk cooling process and before starting the first milk loading, the internal temperature of bulk cooler was of 302.6 K at zero time. After passing 0.1 h, milk volume inside bulk cooler was of 0.044

Fig. 2 Evolution of milk volume inside bulk cooler and its corresponding temperature with the loading and storage time for every day-milk collecting experiments

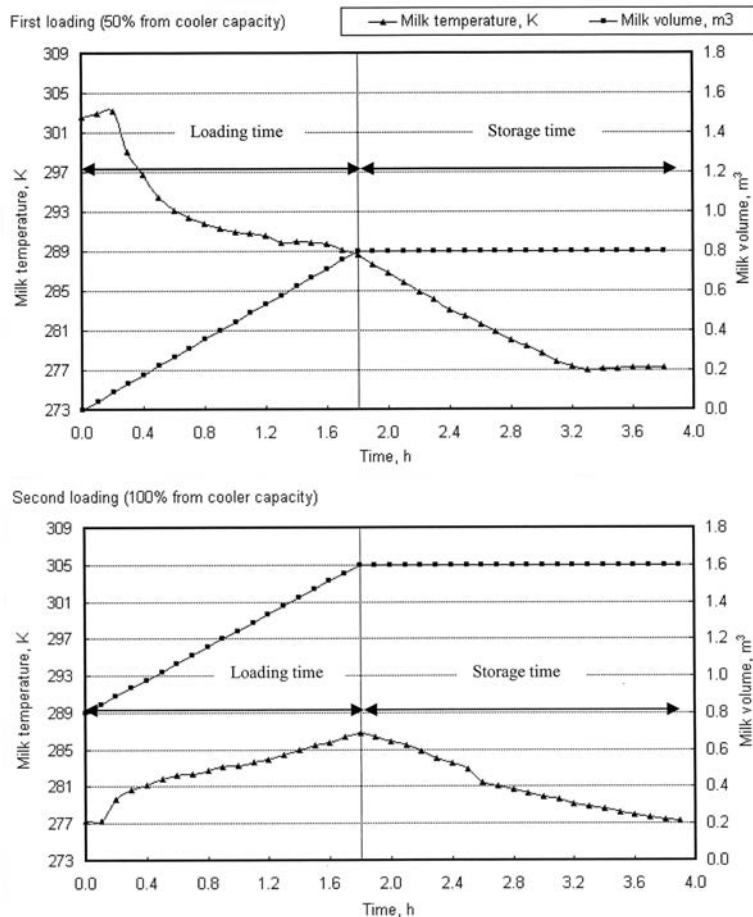

Table 2 Specifications of the bulk-milk cooler designed for every day collection during the first milk loading (50 % from cooler capacity)

Number of loading times	Time, h	Milk volume, m ³	Milk temperature, K	Cooling capacity standards, K
1	0.1	0.044	302.9	-
2	0.2	0.088	303.2	-
18	1.8	0.800	288.6	-
-	2.5	0.800	282.5	-
-	2.8	0.800	280.0	≤ 283.0
-	3.2	0.800	277.4	-
-	3.8	0.800	277.3	≤ 277.4

Table 3 Specifications of bulk-milk cooler designed for every day collection during the second milk loading (100 % from cooler capacity)

Number of loading times	Time, h	Milk volume, m ³	Milk temperature, K	Cooling capacity standards, K
1	0.1	0.844	277.3	-
2	0.2	0.888	279.6	-
18	1.8	1.600	286.8	< 283.0
-	2.8	1.600	280.7	-
-	3.8	1.600	277.4	-

m³ and its corresponding temperature was of 302.9 K. At the second loading, 0.2 h, milk volume inside bulk cooler increased from 0.044 to 0.088 m³ (by 100 %) and its temperature raised from 302.9 to 303.2 K (by 0.1 %). The small percentage increase in milk temperature may have been because the bulk cooler was still in the beginning of its switching on (operation). In 1.8 h, the bulk cooler was approximately 50 % filled with milk (0.8 m³) and the temperature was of 288.6 K. When milk volume was constant at 0.8 m³ and at 2.8 h (one hour from completion of milk loading), milk temperature had decreased from 288.6 to 280 K (by 2.98 %). Accordingly, in one more hour (at 3.8 h and within two hours from completion of milk loading) at constant milk volume of 0.8 m³, milk temperature was lowered from 280 to 277.3 K (by 0.96 %). From the previous discussion, it was obvious that the results for the cooling capacity standards of the bulk cooler for every day milk collection experiments and the required milk temperature was achieved successfully under the

conditions of every day collection through the first loading of the bulk cooler.

The second milk loading for every day collecting experiments (occupying approximately 100 % from cooler capacity), is outlined in **Fig. 2** and listed in **Table 3**. As well as, The progression of milk volume and the corresponding temperature with loading and storage time is depicted in **Fig. 2**. Before starting the second milk loading, milk volume inside bulk cooler was 0.8 m³ and the temperature was of 277.3 K. Similarly, within 0.1 h, milk volume was of 0.844 m³ and the temperature was still constant at 277.3 K. Within 1.8 h, from the initiation of the second milk loading, milk volume inside bulk cooler was approximately of 100 % from its capacity (1.6 m³) and its temperature had reached 286.8 K. This increase in milk temperature was logical and normal because of loading fresh milk to bulk cooler. From the above-mentioned results, it was clear that these results were not in accord with the cooling capacity standards for every day milk collecting experiments under the

second loading conditions and the required temperature of milk (≤ 283K) was not achieved through the second loading of the bulk cooler. The increase in milk temperature over 283 K was referring to the increase of milk volume inside bulk cooler to 100 % of its capacity. Therefore, there was an urgent need to conduct and suggest the condition of every other day milk collection experiments. At the same time, milk volume inside the bulk cooler should be minimized and a suitable capacity of bulk cooler be estimated to be in accord with the condition of cooling capacity standards for every day milk collecting experiments.

Every other Day Milk Collection Experiments:

The first milk loading of the bulk cooler filled it to 25 % of its capacity as depicted in **Fig. 3** and listed in **Table 4**. The progression of milk volume in the bulk cooler and the corresponding temperature with loading and storage time is outlined in **Fig. 3**. The initial (before loading) temperature inside the bulk cooler was of 300 K. After 0.1 h from the start of milk loading, the volume inside the bulk cooler was of 0.022 m³ and its temperature was of 300.4 K. After 0.2 h, milk volume increased to 0.044 m³ (by 100 %) and the temperature increased to 301.5 K (by 0.37 %). The bulk cooler was still in the beginning of its operation (switching on) when this slight increase in milk temperature occurred. Within 1.8 h from the initiation of milk loading (at the end of first milk loading), milk volume was of 0.4 m³ (approximately 25 % of cooler capacity) and the temperature was of 284 K. With a constant milk volume of 0.4 m³ during the period from 1.8 to 2.8 h (within one hour from the beginning of storage time after finishing the loading time), the milk temperature lowered from 284 to 276.9 K (by 2.5 %). In the next hour (at 3.8 h) (within two hours from the beginning of storage time),

Table 4 Specifications of the bulk-milk cooler designed for every other day collection during the first milk loading (25% of cooler capacity)

Number of loading times	Time, h	Milk volume, m ³	Milk temperature, K	Cooling capacity standards, K
1	0.1	0.022	300.4	-
2	0.2	0.044	301.5	-
18	1.8	0.400	284.0	-
-	1.9	0.400	282.9	-
-	2.3	0.400	277.4	-
-	2.8	0.400	276.9	≤ 283.0
-	3.8	0.400	277.4	≤ 277.4

Table 5 Specifications of bulk-milk cooler designed for every other day collection during the second milk loading (50% of cooler capacity)

Number of loading times	Time, h	Milk volume, m ³	Milk temperature, K	Cooling capacity standards, K
1	0.1	0.422	277.9	-
2	0.2	0.444	278.1	-
18	1.8	0.800	281.9	< 283.0
-	2.6	0.800	277.4	-

Fig. 3 Evolution of milk volume inside bulk cooler and its corresponding temperature with the loading and storage time for every other day-milk collecting experiments

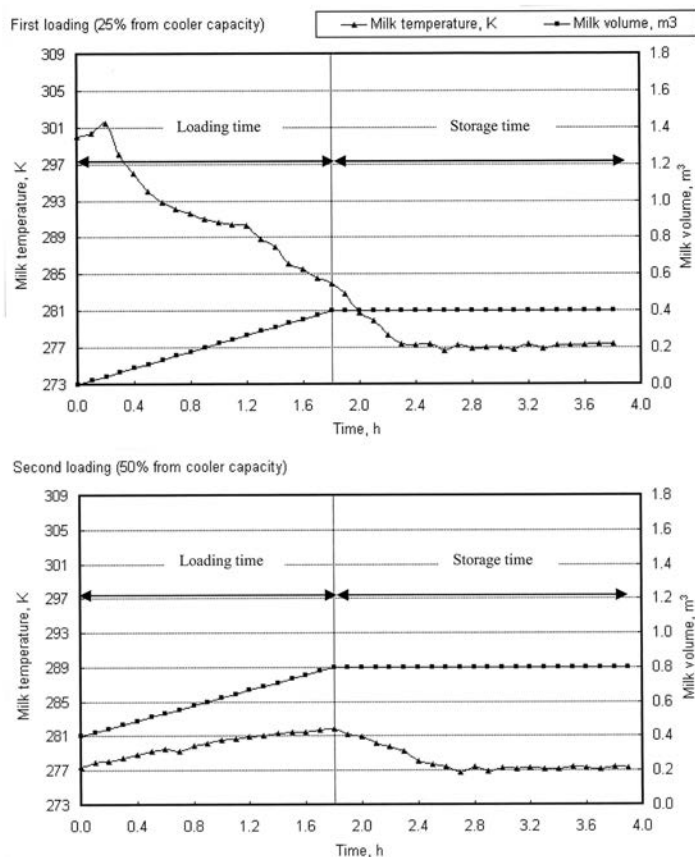

with no change in milk volume, the milk temperature increased to 277.4 K. From the previous results, it was obvious that the required temperature of milk inside the bulk cooler was successfully achieved at the first loading by filling it to 25 % of its capacity with milk. This confirmed and, hence, satisfied the conditions of cooling capacity standards. Additionally, when the bulk cooler was filled to 25 % of its capacity, milk temperature reached 277.4 K after only 0.5 h of storage time. Therefore, there was no need to spend two hours to get 277.4 K milk temperature. The increase in cooling efficiency of the bulk cooler was mainly due to the small capacity of milk inside bulk cooler.

The second milk loading is depicted in **Fig. 3** when the bulk cooler was filled to 50 % capacity. Loading of milk into the bulk cooler and the corresponding temperature with the loading and storage time is outlined in **Fig. 3** and listed in **Table 5**. At the beginning of the second loading, milk volume was of 0.4 m³ and its temperature was 277.4 K. Within the first 0.1 h after loading, milk volume was of 0.422 m³ (increased by 5.5 %) with a temperature was of 277.9 K (raised by 0.18 %). At 0.2 h, milk volume increased from 0.422 to 0.444 m³ (by 5.21 %) and the temperature increased to 278.1 K (by 0.07 %). The increase in milk temperature by such a small percent was expected due to loading the bulk cooler with fresh milk. After 1.8 h, milk volume reached 0.8 m³ (approximately 50 % of cooler capacity) and temperature reached 281.9 K (the desired temperature for safe storage of milk for marketing or processing). The results beforehand accorded with the condition of second loading for cooling capacity standards (when filling the bulk cooler with milk to 50 % of its capacity and milk temperature should not exceed 283 K).

It was very necessary to reveal that milk temperature was dramati-

cally increased during the second milk loading and as long as milk was added continually to the bulk cooler. Conversely, when loading time was finished, the milk temperature began to decrease gradually until it reached the recommended level for safe storage. For example, during the second milk loading, milk temperature increased from 277.3 to 286.8 K (by 3.43 %) and from 277.9 to 281.9 K (by 1.44 %) for both every day and every other day milk collection experiments, respectively. On the other hand, during the first milk loading and within loading time, milk temperature reduced from 302.9 to 288.6 K (by 4.72 %) and from 300.4 to 284 K (by 5.46 %) for both every day and every other day milk collection experiments, respectively (see Fig.

2 and 3).

Cooling Capacity of the Bulk-Milk Cooler:

For selecting and suggesting the optimum conditions to collect milk inside the bulk cooler, cooling capacity was estimated at the first and second milk loading for both every and every other day collection experiments. As listed in Table 6 and outlined in Fig. 4, the values of cooling capacity were dramatically increased with the loading time for both every day and every other day collection experiments. For every day milk collection experiments, the values of cooling capacity ranged from 1.487 to 26.020 MJ/h and from 0.093 to 30.574 MJ/h at the first and second milk loading, respectively, as time from loading elapsed from

0.1 to 1.8 h. On the other hand, for every other day milk collection experiments, the values of cooling capacity ranged from 0.945 to 21.467 MJ/h and from 0.344 to 18.296 MJ/h at the first and second milk loading, respectively, as time elapsed from 0.1 to 1.8 h. In general, the values of cooling capacity for every day milk collection experiments were higher than that for every other day. This was attributed to the increase of milk loading to the bulk cooler when it was loaded to 50 and 100 % of its capacity.

For every day milk collection experiments, at the first milk loading, when milk volume was constant at 0.8 m³ and its temperature ranged from 288.6 to 277.4 K, cooling capacity of the bulk cooler was 26.020 MJ/h, while the storage time elapsed from 1.8 to 3.2 h. In the same manner, cooling capacity of the bulk cooler was 30.574 MJ/h at constant milk volume of 1.6 m³ while milk temperature ranged from 286.8 to 277.4 K and elapsed storage time ranged from 1.8 to 3.8 h. As listed in table 6, there was an increased percentage of cooling capacity during the second milk loading by 17.51 % as compared to the first one. The increase of cooling capacity was due to the increase of milk volume inside the bulk cooler, which had been taking place during the second loading for every day milk collection. For every other day milk collection, and at a constant milk volume of 0.4 m³ during the first milk loading, cooling capacity of the bulk cooler was of 21.467 MJ/h, while milk temperature ranged from 284 to 277.4 K and elapsing storage time from 1.8 to 2.3 h. Similarly, cooling capacity was determined during the second milk loading and was 18.296 MJ/h when milk volume was constant at 0.8 m³ and milk temperature ranged from 281.9 to 277.4 K. Simultaneously, the storage time elapsed from 1.8 to 2.6 h. As indicated in table 6, cooling capacity was reduced by 14.77 %. This reduction might have

Fig. 3 Variation of cooling capacities of bulk-milk cooler with the loading time for both every and every other day-milk collecting experiments

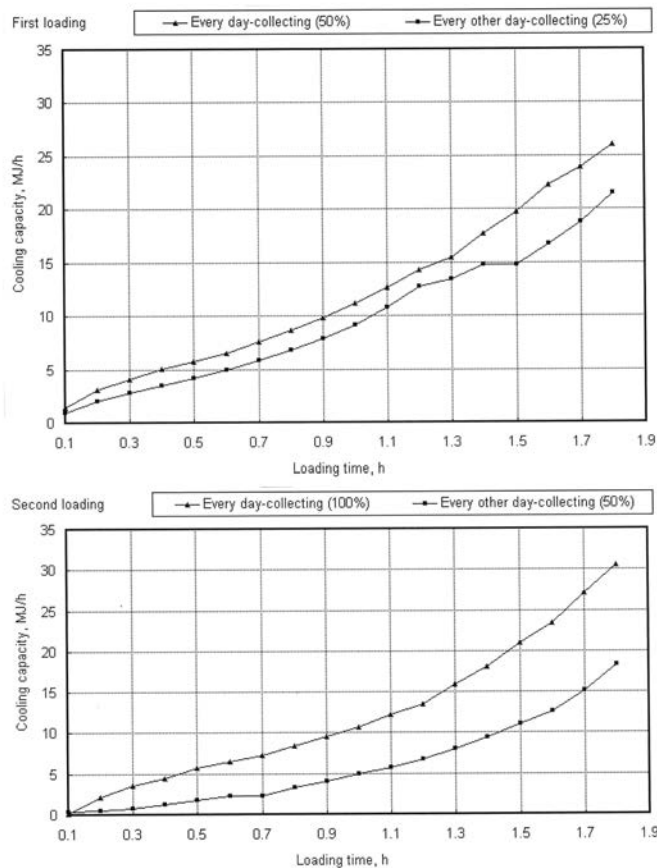

Table 6 The calculated values of cooling capacity of bulk-milk cooler at different milk loading capacities and the investigated variables

No. of milk Loading	Loading time, h	Every other day collection experiments						Every day- collection experiments					
		The second milk loading (50% from cooler capacity)			The first milk loading (25% from cooler capacity)			The second milk loading (100% from cooler capacity)			The first milk loading (50% from cooler capacity)		
		Milk temp., K	Milk volume, m ³	Cooling capacity, MJ/h	Milk temp., K	Milk volume, m ³	Cooling capacity, MJ/h	Milk temp., K	Milk volume, m ³	Cooling capacity, MJ/h	Milk temp., K	Milk volume, m ³	Cooling capacity, MJ/h
1	0.1	302.9	0.044	1.487	277.3	0.844	0.093	300.4	0.022	0.945	277.9	0.422	0.344
2	0.2	303.2	0.089	3.108	279.6	0.889	2.208	301.5	0.044	2.073	278.1	0.444	0.527
3	0.3	299.1	0.133	4.056	280.7	0.933	3.578	298.0	0.067	2.792	278.4	0.467	0.824
4	0.4	296.8	0.178	5.008	281.2	0.978	4.443	296.0	0.089	3.538	278.8	0.489	1.264
5	0.5	294.5	0.222	5.722	281.9	1.022	5.667	294.0	0.111	4.166	279.2	0.511	1.781
6	0.6	293.1	0.267	6.546	282.2	1.067	6.506	292.8	0.133	4.911	279.5	0.533	2.276
7	0.7	292.4	0.311	7.589	282.4	1.111	7.286	292.1	0.156	5.810	279.3	0.556	2.259
8	0.8	291.8	0.356	8.673	282.8	1.155	8.457	291.6	0.178	6.843	279.9	0.578	3.263
9	0.9	291.3	0.400	9.829	283.1	1.200	9.590	291.0	0.200	7.899	280.2	0.600	4.018
10	1.0	291.0	0.444	11.171	283.3	1.244	10.661	290.6	0.222	9.174	280.5	0.622	4.901
11	1.1	290.8	0.489	12.683	283.7	1.289	12.227	290.4	0.244	10.767	280.7	0.644	5.765
12	1.2	290.6	0.533	14.311	283.9	1.333	13.552	290.3	0.267	12.715	280.9	0.667	6.776
13	1.3	289.9	0.578	15.454	284.5	1.378	15.909	288.8	0.289	13.390	281.1	0.689	7.972
14	1.4	290.0	0.622	17.708	284.9	1.422	18.070	287.9	0.311	14.757	281.3	0.711	9.397
15	1.5	289.8	0.667	19.770	285.5	1.467	21.000	286.1	0.333	14.738	281.5	0.733	11.113
16	1.6	289.7	0.711	22.226	285.8	1.511	23.457	285.5	0.356	16.728	281.5	0.755	12.594
17	1.7	289.1	0.755	23.960	286.4	1.555	27.105	284.6	0.378	18.731	281.7	0.778	15.109
18	1.8	288.6	0.800	26.020	286.8	1.600	30.574	284.0	0.400	21.467	281.9	0.800	18.296

been due to the increase of storage time during the second milk loading.

Determination of Bulk-Milk Cooler Capacity:

Concerning the second milk loading for every day collection experiments, when milk volume inside bulk cooler was constant at 1.6 m³ (approximately 100 % of cooler capacity), milk temperature was 286.8 K and was not in accord with cooling capacity standards for every day milk collection since milk temperature under these conditions must not exceed 283 K. Therefore, as listed in **Table 7**, there was an urgent need to calculate the suitable and safe milk volume by using the Arithmetic Interpolation Method. As indicated in **Table 7** it was necessary to add 0.027 m³ every 0.1 h, during the second milk loading, instead of 0.044 m³ to avoid the increase in milk temperature. If the number of milk loading times during the second loading was 18 times, then the total volume of milk could be calculated as: $18 \times 0.027 = 0.486 \text{ m}^3$. Accordingly, the bulk cooler capacity during the first and second milk loading for every day collection experiments would equal to $0.800 + 0.486 = 1.286 \text{ m}^3$. From the before mentioned results, it can be concluded that, in order to maintain milk temperature at the recommended level, the bulk cooler should be loaded with only about 60.75 % (0.486 m³) of its capacity during the second milk loading and only about 80.38 % (1.286 m³) during the first and second milk loadings as a whole.

One of the important results obtained from this work was a multiplicative model. Four multiple linear regression equations were developed to describe the relationship between the cooling capacity of the bulk cooler as a dependent variable and milk loading time, milk temperature and milk volume as independent variables. As indicated in **Table 8**,

the constants of this multiplicative model were determined by performing multiple linear regression analysis. The multiplicative model had the following form:

$$CC = a_0 + b_1t + b_2T + b_3V \dots \dots (2)$$

where

CC cooling capacity of bulk-milk cooler, MJ/h;

t milk loading time, h;

T milk temperature, K;

V milk volume, m³;

a₀ Y-intercept and

b₁, b₂ and b₃ regression coefficients.

The accuracy of the relationships was measured by the coefficients of multiple determination (R²). The coefficients of determination were greater than 0.964 in most cases (Table 8). In practice, the use of the previous relationships can be applied to predict the values of cooling capacity of bulk cooler within the designed experimental limits of the investigated variables.

Conclusion

For calibrating and evaluating the performance of the bulk-milk cooler under every day and every other day milk collection conditions, the following conclusions should be taken into consideration and can be deduced as follows.

1. The applied recommendations for operating the bulk-milk cooler can be concluded in the following

Table 9.

2. For every day milk collection experiments, the bulk milk cooler capacity should not exceed 80.38 % (1.286 m³) of milk to maintain milk temperature at the recommended level for safe storage and marketing.

3. During the second milk loading, milk temperature was increased by 3.43 and 1.44 % for both every day and every other day milk collection experiments, respectively. Conversely, during the first milk loading, milk temperature was reduced by 4.72 and 5.46 % for

both every day and every other day milk collection experiments, respectively.

REFERENCES

- Barre, H. J., L. L. Sammet, and G. L. Nelson. 1988. Environmental and functional engineering of agricultural buildings. Van Nostrand Reinhold Company Inc., 115 Fifth Avenue, New York 10003, USA.
- Campbell, J. R. and R. T. Marshall. 1975. The science of providing milk for man. McGraw-Hill Inc., USA.
- CIHEAM. 2006. Agri. Med. Agriculture, fishery, food and sus-

Table 9 Recommended operation of Bulk-milk cooler depending on the situation

Performance parameter	Every day milk collection experiments			Every other day milk collection experiments		
	At the end of first loading	At the end of second loading	% Change	At the end of first loading	At the end of second loading	% Change
Cooler capacity, m ³	0.800	1.600	100 % increase	0.400	0.800	100 % increase
Cooler capacity according to cooling capacity standards, m ³	0.800	1.286	60.75 % increase	0.400	0.800	100 % increase
Milk temperature, K	288.6	286.8	0.62 % decrease	284.0	281.9	0.74 % decrease
Milk loading time, h	1.8	1.8	-	1.8	1.8	-
Cooler cooling capacity, MJ/h	26.020	30.574	17.51 % increase	21.467	18.296	14.77 % decrease

Table 7 The convenient milk volume inside bulk-milk cooler for both every day and every other day milk collection experiments

At the second milk loading	Milk temperature, K	Milk volume for every 0.1h, m ³
Every day milk collection experiments	286.8	0.044
Cooling capacity standards for every and every other day milk collection experiments	<283.0 ≈ 282.9	0.027
Every other day milk collection experiments	281.9	0.022

Table 8 Regression coefficients, describing the relationship between cooling capacity and investigated variables

Cooling capacity		Y-intercept (a ₀)	Regression coefficients			Determination coefficient (R ²)
			b ₁	b ₂	b ₃	
Every day collection experiments	First loading (50 %)	-146.210	+51.439	+0.483	-76.320	0.990
	Second loading (100 %)	+75.947	+17.759	-0.280	-1.091	0.946
Every other day collection experiments	First loading (25 %)	-147.401	-80.858	+0.487	+435.106	0.987
	Second loading (50 %)	+2,395.376	+275.214	-7.020	-1,119.748	0.964

tainable rural development in the Mediterranean Region. Annual report in Arabic 2006. Paris, France.

Farrall, A. W. 1963. Engineering for dairy and food products. J 31, South Extension 1, New Delhi 3, India.

Judkins, H. F. and H. A. Keener. 1960. Milk production and processing. John Wiley and Sons, Inc., USA.

Maton, A., J. Daelemans and J. Lambrecht. 1985. Housing of animals, Construction and equipment of animal houses. Elsevier science publishers B. V., The Netherlands.

Raynal, K. and F. Remeuf. 2000. Effect of storage at 4 °C on the physicochemical and renneting properties of milk: a comparison of caprine, ovine and bovine milks. J. of Dairy Research, 67(2): 199-207.

Sainsbury, D. and P. Sainsbury. 1982. Livestock health and housing. Butler and Tanner Ltd, Rome and London. Great Britain. ■■

New Co-operating Editors



Dr. Indra Mani

Division of Agricultural Engineering
IARI New Delhi-110012, INDIA

Dr Indra Mani is currently serving as Senior Scientist in the Division of Agricultural Engineering, Indian Agricultural Research Institute (IARI), New Delhi. His major contributions include design of a number of agricultural machine for Indian farmers, 15 years experience of post graduate teaching and guidance of M. Sc. and Ph. D. students at IARI. He has published more than 85 research papers, technical bulletins and book chapters and number of popular articles.



Dr. C. R. Mehta

Principal Scientist & Head Agricultural Mechanization Division Central Institute of Agricultural Engineering, INDIA

Research Areas: Conservation Agriculture, Farm Machinery Management, Ergonomics and Instrumentation

Ph.D. Indian Institute of Technology, Kharagpur- 2000

Dr. C. R. Mehta is a life member of Indian Society of Agricultural Engineers (ISAE), as well as Indian Society of Ergonomics (ISE). He has won many awards related to agricultural machinery, such as "Distinguished Service Certificate (2002-03) for R & D in farm Machinery & Power (ISAE)", Commendation Medal (2005-06) for R & D in Farm Machinery & Power (ISAE), and ISAE Team Award. He has also been writing many books for publications, utilizing his wealth of knowledge. He is a well-known writer of AMA, submitting numbers of essential papers. We are looking forward to his continuous contribution, both as a writer and a co-editor.

ERRATA

	ERROR	CORRECT
AMA Vol. 43, No. 1 Winter, 2012 Page 17 new co-author's nationality	Mohammad Ali Basunia Nationality: OMAN	Mohammad Ali Basunia Nationality: BANGLADESHI

Development in a Small Prototype Gin Stand for Egyptian Cotton



by
Abd El-Hameed

S. E. Bader

A. E. Elyamani

Agricultural Engineering Res. Institute, Agric. Research Center,
Dokki, Giza, EGYPT
Samykhadr@yahoo.com

Abstract

This research developed and evaluated the performance of a small prototype machine for ginning Egyptian cotton in a laboratory. This machine helped technicians and scholars study the effect of experimental parameters on fiber cotton quality properties. The independent variables in this study were: four values of rotation at speeds of 0.79 m/s (60 rpm), 1.18 m/s (90 rpm), 1.60 m/s (120 rpm), and 2.00 m/s (180 rpm). The three values of feeding rate were 8 kg/h, 10 kg/h, 12 kg/h and the three values of clearance between two drums were 3, 4 and 5 mm. Evaluation parameters were: gin stand productivity, lint turnout, seed wastage mass, gin lint losses and ginning efficiency. Also, energy requirement and total cost of production were determined. A comparative study between the developed prototype gin machine and the conventional McCarthy roller gin was made by evaluating fiber properties. The results for developed gin stand performance found that a maximum of ginning efficiency, gin stand capacity, lint turn out percentage were 81.28 %, 6.87 kg, and 43.1 %, respectively. Also, the maximum seed wastage mass was 4.211 kg and minimum gin lint losses percentage

was 3.5 % with a minimum energy requirement of 154.26 kWh/Mg. On the other hand, minimum total operation cost was 231.40 LE/Mg while minimum criterion function cost was 364.10 LE/Mg. Generally, the new developed prototype machine was influenced by all independent variables. Recently, a comparative study between the developed gin stand and the conventional McCarthy gin roller on the physical fiber quality properties found that the gin stand developed was considered the best for ginning Egyptian seed cotton samples.

Introduction

Cotton is the most important fiber crop in the world as well as in Egypt. But this plant is exposed to many pests, so the country spends millions of pounds to increase production by helping the technicians control the pests. These pests can annihilate all crops if it not controlled. Also, they can reduce fibers and seed quality.

Anthony and Wesley (1979) determined the effects of individual processing machines and combinations on lint quality and their electric consumption. Of the 14 machine combinations investigated, the treat-

ment that included 2 tower driers, a cylinder cleaner, stick machine, impact cleaner, gin stand and 2 stages of lint cleaning produced the highest classer's grade, the lowest trash content and lint turnout from both the high and low moisture content seed cotton samples. Treatments which included only the gin stand and one lint cleaner produced classer's grades among the highest and lint trash contents among the lowest. Lint turnouts for these treatments ranked in the intermediate range. About 55-60 % of the total energy required by maximum machine processing was consumed by the fans and separators. The lower moisture cotton consumed 20-40 % more electric energy/kg of seed cotton processed. Hossam el-din (1978) and Eweida *et al.* (1984) found that the feeding rate of seed cotton to gin-stand significantly affected capacity, ginning time and non-lint content. Hughs *et al.* (1983) found that the total nonlint content of the cotton fiber and most quality factors measured for the cotton lint processed through the experimental gin-cleaner were generally as good if not better than the same quality factors for lint processed through standard cleaning equipment. Anthony (1985) discussed the different features of a ginning machine, the

controls and the maintenance which, along with the humidity, have an effect in limiting the deterioration of cottonseed and cotton fiber quality (percentage of short fiber and presence of foreign material and seed husk debris). Results quoted were from tests at the Cotton Ginning Laboratory. Anthony (1989) reported that processing cotton at the gin to minimize machinery usage and maximize monetary returns required a thorough understanding of the performance characteristics of individual machines. A database involving multiple moisture, trash, machine and cotton levels was developed for all routine and laboratory fiber properties before and after various gin processes. Ranges of these variables were representative of the minimum and maximum levels normally found in spindle-harvested cotton. The database was suitable for multiple regression analyses and development of prediction equations based on the performance characteristics of individual and combinations of machines.

Rafiq-Chaudhry (1997) found that about 85 % of total cotton in the world is ginned on saw gins. Most countries have either large scale saw ginning or roller ginning, although small scale roller ginning does exist in some countries. Among the major cotton producing countries of the world, India and Turkey are the only countries where saw ginning and roller ginning are popular. Ginning

is most expensive in Spain followed by Argentina, Zimbabwe, Australia and Colombia. Ginning is heavily subsidized in China (mainland). Mangialardi and Anthony (2000) found that, cotton (*Gossypium hirsutum* L.) fibers are cleaned at gins with saw-type lint cleaners to improve the market value, but the aggressive saws sometimes harm the quality of the fiber. The cleaning efficiency of one saw-type lint cleaner averaged 54 %, and the efficiencies of seed cotton cleaners used as lint cleaners ranged from 9 to 16 %. There was a significant improvement in the classer's leaf grade designations when lint was cleaned with each of the seed cotton-type cleaners. Staple lengths tended to be shorter after cleaning with saw-type cleaners. A modified non-saw cleaner appears practical and could help preserve fiber quality at cotton gins.

Patil *et al.* (2006) found that the foot operated gin and the Lilliput gin have a ginning output capacity of 0.311 and 2.111 kg lint/h, respectively. The 2.5 % span length and uniformity ratio remained practically the same for hand ginning, foot operated gin and the Lilliput gin. So, the foot operated gin was much more suitable for farmers because it was economical and auxiliary power was not required for its operation. The Lilliput gin was the most popular amongst the cotton breeders, traders and seed indus-

tries. Whitelock *et al.* (2007) stated that most gins use one or two cylinder cleaners and an air-type lint cleaner for lint cleaning. The trend in roller ginning today has been toward aggressive seed-cotton cleaning and gentle lint cleaning to limit fiber damage. The aim of the present study was to develop and evaluate a simple prototype machine to gin Egyptian cotton in the laboratory to help technicians and scholars study the effect of any treatments during operation on fiber cotton quality properties.

Materials and Methods

The developed gin stand was designed to be used as a ginning system for mechanical harvested seed cotton to study the effect of engineering parameters of the gin stand like the effects of values of rotation drum speed, values of feed rate, values of clearance between two drums and values of inclination angle of drums with the horizontal axis to estimate the optimum conditions for operation. Another objective was to estimate energy requirements and operating cost essential for operation and compare its performance with the conventional McCarthy roller gin to determine the machine effects of two different gin stands on physical fiber properties.

The Developed Gin Stand

A prototype reciprocating-knife gin having a roller length of 70 cm was made. The adjustment of moving parts was set according to the conventional settings, which were usually followed with respect to each variety and grade. The power source of the machine was electricity (0.36 kW). The input power was controlled by a potentiometer to adjust the operating speed. The speeds of different moving parts of the gin stand were fixed and measured by a speedometer. The developed gin machine was fabricated and cali-

Fig. 1 Schematic diagram of the developed gin stand

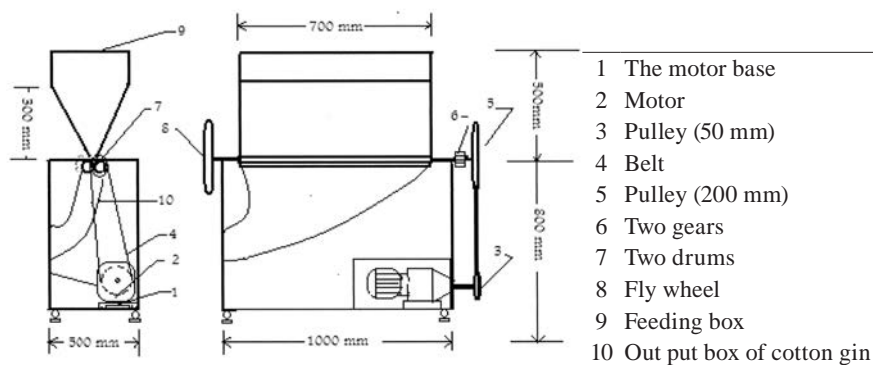

brated in private local workshops at Sofia village, El-Sharkeia Governorate. **Fig. 1** shows a schematic diagram of the developed gin stand. The main components of the developed gin machine were as follows:

1. Rolls: were made from wood covered by natural leather. The gin stand had two rolls used for separating cotton fibers and seeds. Ginned cotton fibres were carried onward in the direction of the leather roller; a stripping board stripped the fibres from the leather roller and the emptied seeds were thrown into the grid through which they passed into a suitable receptacle. The dimensions: length 700 mm, drum diameter 125 mm and machine weight 65 kg.

2. Moving knife and stationary knife: the knife serves three purposes

- a) help guide (with the roller) seed cotton to the ginning point;
- b) remove seed away from the ginning point; and
- c) remove any seed cotton not able to be ginned (carryover).

3. Fly wheel: Made from iron with diameter 380 mm. This diameter is kept on the balanced of machine.

The Conventional McCarthy Gin Roller

The physical fiber quality parameters of the developed machine were compared with the conventional McCarthy gin roller (**Fig. 2**), rotational speed (950 rpm) to evaluate the machine effects. It had the fol-

lowing component parts of

- a) parts for the separation of the fiber from the seed: these included fixed knife, moving knife and roller. These were called the main parts of the gin stand.
- b) Parts assistance to parts of the separation of the fiber from the seed: they include pusher board, seed grid and doffer.
- c) Parts of transmission: these included crank shaft, employment pulley, unemployment pulley and the transfer of traffic pulleys.
- d) Complementary parts like the fund fiber, in addition to the structure gin stand which consisted of the thighs.

Treatments:

Four values of rotational (speed) were 0.79 m/s (60 rpm), 1.18 m/s (90 rpm), 1.60 m/s (120 rpm), and 2.00 m/s (180 rpm). Three values of feeding rate were 8 kg/h, 10 kg/h, 12 kg/h and three values of clearance between two drums were 3, 4 and 5 mm. The following measurements were carried out to investigate the effect of previously mentioned parameters on the machine performance.

1. Machine Productivity

The machine productivity (Q) was calculated by using the following formula:

$$\text{Machine productivity, kg / h} = \frac{[\text{Mass of input cotton, kg}]}{[\text{The time consumption for ginning, h}]} \dots\dots\dots (1)$$

2. Ginning out turn

The percentage of ginning turnout was determined by using the following formula

$$\text{Ginning out turn, \%} = \frac{[\text{Lint mass, kg}]}{[\text{Seed cotton mass, kg}]} \dots\dots\dots (2)$$

3. Gin lint losses

Total weight of ginned lint losses was determined by using the following formula

$$\text{Gin lint losses, kg} = (\text{Weight of sample before ginning, kg}) - [(\text{lint productivity, kg/h}) + (\text{seed wastage mas, kg})] \dots\dots\dots (3)$$

4. Ginning efficiency

The percentage of ginning efficiency was determined by using the following formula

$$\text{Ginning efficiency, \%} = \frac{[\text{Seed cotton mass before ginning, kg}] - (\text{Seed wastage mass, kg})}{[\text{Seed cotton mass before ginning, kg}]} \dots\dots\dots (4)$$

Where, seed wastage mass is seed cotton mass without ginning.

5. Energy requirement

The required power was calculated according to the following formula (Gustafson, 1980):

$$\text{The consumed energy, (kWh/ Mg)} = \frac{[\text{Total power consumption (kW)}]}{[\text{Machine productivity (Mg/h)}]} \dots\dots\dots (5)$$

Where:

$$\text{Total required power, kW} = \frac{\sqrt{2} I V \cos \theta}{1000} \dots\dots\dots (6)$$

- I = Electric current, ampere;
- V = Electric potential, voltage (220 V);
- cos θ = Power factor (being equal 0.486)
- √2 = Coefficient current two phases (being equal 1.4).

The human energy was calculated with the following equation:

$$\text{Human energy} = \frac{[\text{Manpower, kW}]}{[\text{Manual productivity, Mg / h}]} \dots\dots\dots (7)$$

The manpower was computed by assuming that one normal laborer supplied 0.0748 kW according to (Ezeike, 1987) cited by (Matouk et al., 1999).

Fig. 2 Cross section of the conventional McCarthy gin roller (A) and the main parts of gin stand (B)

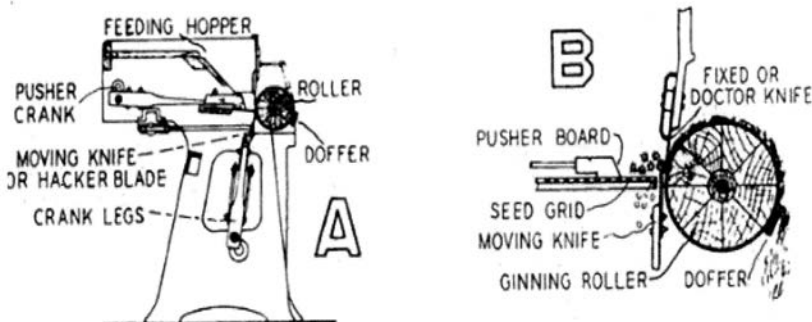

6. Operational cost of the unit

The total cost was determined by using the following equation (Awady, 1978)

$$C = p/h (1/a + i + t/2 + r) + (Ec \times Ep) + m/144 \dots\dots\dots (8)$$

Where:

- h = Yearly working hours h/ year
- c = Operation hourly cost, LE/ h.
- Ep = Electricity price, (EL/ kW.h)
- p = Price of machine, LE
- r = Overheads and indirect cost ratio
- Ec = Electricity energy consumption, (kW/h)
- m = Monthly average wage, LE
- a = Life expectancy of the machine, h
- t = Taxes ratio
- i = Interest rate/year.
- 144 = The estimated monthly working hours, h/month.

Also,

$$\text{Unit operating cost, LE / Mg} = [\text{Pr otype cost (LE / h)} / \text{Pr oductivity (Mg / h)}] \dots\dots\dots (9)$$

$$\text{Criterion Function Cost, LE/Mg} = \text{unit operating cost, LE/Mg} + \text{Losses cost, LE/Mg} \dots\dots\dots (10)$$

$$\text{Losses cost, LE/Mg} = \text{value of lint wastage} + \text{fewness in cotton seed price according to reducing seed damaged} \dots\dots\dots (11)$$

7. The physical fiber quality properties

The physical fiber properties were determined at the fiber testing laboratory, CRI, ARC, Giza. As follows:

A Fiber length: The digital fibrograph model 630 was used to determine 2.5 and 5 % span fiber length according to May and Bridges, (1995).

B Uniformity ratio: Determined by using the following formula while it had 2 cm diameter round holes with saw drum concaves

$$\text{Uniformity ratio, \%} = [50 \% \text{ span fiber length} / 2.5 \% \text{ span fiber length}] \times 100 \dots\dots\dots (12)$$

and was expressed on uniformity quantity between short and long fi-

ber length.

C Lint Color: HVI 9000 according to ASTM (D-1684-96) estimated lint color (reflectance Rd, % and yellowness +b)

D Fiber strength and elongation: Measured by using the stelometer instrument at the fiber testing laboratory, CRI, ARC according to (ASTM, designated D-1445-75, 1984). This instrument gave elongation readings and cotton strength can be determined by using the following formula:

$$c = \text{Operation hourly cost, LE/ h.}$$

$$h = \text{Yearly working hours h/ year}$$

$$p = \text{Price of machine, L.E.}$$

$$Ep = \text{Electricity price, (EL/ kW.h)}$$

$$Ec = \text{Electricity energy consumption, (kW/h)}$$

$$r = \text{Overheads and indirect cost ratio}$$

$$a = \text{Life expectancy of the machine, h}$$

$$m = \text{Monthly average wage, LE}$$

$$i = \text{Interest rate/year.}$$

$$t = \text{Taxes ratio}$$

$$144 = \text{The estimated monthly working hours, h/month.}$$

$$\text{(Strength for length unit, g/tex)} = [(\text{Cutting mass, kg} \times 1.5) / \text{Mass of sample, mlg}] \times 100 \dots\dots\dots (13)$$

Results and Discussion

Primordial Test:

The primary experiment was carried out during the 2009 season with seed cotton variety Giza 89 with using the conventional McCarthy gin roller, to determine the effect of some independent variables such as drum speed, feed rate and clearance between drums on gin stand performance. **Table 1** shows the average of the conventional McCarthy gin roller processing data. This study proved that this machine is not suitable for low feed rates and, therefore, they do not fit the research tests as it was designed for produc-

tion only. And, therefore, there was an urgent need for a model of ginning machine suitable for research experiments. For this reason, this has been the subject of the machine design of the present study.

Performance of the Developed Gin Stand Machine:

1. Gin stand productivity, kg/h:

Table 2 and **Fig. 3** shows the average gin processing for raw seed cotton variety Giza 89 usage development gin stand machine. The data illustrate that gin stand productivity was affected by drum speed, feed rate and clearance between drums. Also gin stand productivity was increased by increasing all of the drum speeds, feed rate and clearance between drums, whereas, at constant feed rate and clearance between drums at 8 kg/h and 3 mm and increased drum speed from 0.79 m/s to 2.00 m/s, gin stand productivity increased from 4.09 kg/h to 4.30 kg/h (+5.13 %). While, with increasing feed rate from 8 kg/h to 12 kg/h at constancy drum speed and clearance between drums at 0.79 m/s and 3 mm, respectively, gin stand productivity increased from 4.09 kg/h to 5.98 kg/h (+46.2 %). Also, at increased clearance between drums from 3 mm to 5 mm at constant drum speed and feed rate at 8 kg/h and 0.79 m/s, gin stand productivity increased from 4.09 kg/h to 4.19 kg/h (+2.45 %). From previous results, feed rate was considered a very important factor affecting gin stand productivity. On the other hand, a maximum gin stands productivity of 6.87 kg/h was recorded at a drum speed of 2.00 m/s, feed rate of 12 kg/h and clearance between drums

Table 1 Average of the conventional McCarthy gin roller processing data

Factor	Amount
Lint system ginning efficiency, %	73.8
Gin turn out, %	28.6
Lint loss, %	4.6
Ginning rate, kg / saw / h	10.4

of 5 mm.

2. Lint turn out, %:

Table 2 and Fig. 4 indicate that, increasing drum speed and clearance between drums led to increase lint turn out, while increasing feed rate led to decrease lint turn out. At constant feed rate and clearance between drums of 8 kg/h and 3 mm with increasing drum speed from 0.79 m/s to 2.00 m/s, lint turn out increased from 39.4 % to 41.4 % (+5.1 %). On the contrary, at a feed rate and drum speed of 8 kg/h

and 0.79 m/s, lint turnout increased from 39.4 % to 40.3 % (+2.28 %). At drum speed of 0.79 m/s and clearance between drums of 3 mm and by increasing feed rate from 8 kg/h to 12 kg/h, lint turn out decreased from 39.4 % to 38.3 % (-2.8 %). The maximum value of lint turn out was 43.1 % recorded at a drum speed of 2.00 m/s, feed rate of 8 kg/h and clearance between drums of 5 mm.

3. Seed wastage mass, kg:

Table 2 and Fig. 5 indicate that, seed wastage mass tends to increase

with increasing drum speed, feed rate and clearance between drums. On the whole, a maximum amount of seed wastage mass was 4.211 kg at a feed rate of 12 kg/h, drum speed of 2.00 m/s and clearance between drums of 5 mm. It was clear that, a feed rate of 8 kg/h, clearance between drums of 3 mm and increasing drum speed from 0.79 m/s to 2.00 m/s, seed wastage mass increased from 1.497 kg to 2.235 kg (+49.3 %). Also, at a drum speed of 0.79 m/s, clearance between drums

Table 2 Means of performance characteristics of the developed gin stand machine

Feeding rate, kg/h	Clearance between drums, mm	Speeds of drum, m/s	Gin stand productivity, kg/h	Lint turnout, %	Seed wastage mass, kg	Lint losses, %	Ginning efficiency, %	Energy requirements, kWh/Mg
8	3	0.79	4.14	39.8	1.497	6.98	81.28	170.89
		1.18	4.20	40.3	1.731	9.15	78.36	181.55
		1.60	4.25	40.8	1.971	10.03	75.36	188.72
		2.00	4.30	41.4	2.235	10.64	72.06	196.32
	4	0.79	4.09	39.4	1.886	9.21	80.00	167.71
		1.18	4.28	41.1	2.220	9.63	72.25	176.41
		1.60	4.33	41.8	2.410	10.18	69.87	185.16
		2.00	4.41	42.5	2.632	11.25	67.10	191.27
	5	0.79	4.19	40.3	2.197	10.91	72.53	163.57
		1.18	4.35	41.8	2.313	12.02	71.08	172.36
		1.60	4.40	42.3	2.511	12.59	68.61	182.11
		2.00	4.47	43.1	2.807	13.79	64.91	187.08
10	3	0.79	4.99	38.4	1.931	5.19	80.69	166.44
		1.18	5.20	40.0	2.210	6.99	77.90	170.24
		1.60	5.30	40.8	2.320	7.37	76.80	174.35
		2.00	5.38	41.4	2.711	8.08	72.89	181.43
	4	0.79	5.10	39.2	2.479	6.88	75.21	162.27
		1.18	5.29	40.2	2.972	6.96	70.28	167.35
		1.60	5.42	41.7	3.101	7.19	68.99	169.23
		2.00	5.50	42.3	3.294	8.19	67.06	176.62
	5	0.79	5.24	40.3	2.703	8.21	72.97	158.99
		1.18	5.37	41.3	3.120	8.67	68.80	164.36
		1.60	5.48	42.2	3.301	9.79	66.99	167.05
		2.00	5.59	43.0	3.435	10.60	65.65	171.13
12	3	0.79	5.98	38.3	2.703	3.50	77.47	161.17
		1.18	6.23	39.9	3.110	4.95	74.08	166.46
		1.60	6.31	40.4	3.560	5.76	70.33	170.13
		2.00	6.45	40.8	3.722	5.84	68.98	178.25
	4	0.79	6.09	38.3	3.190	4.85	73.41	157.12
		1.18	6.33	40.5	3.511	5.24	70.74	162.23
		1.60	6.41	41.1	3.863	5.68	67.81	168.19
		2.00	6.56	41.6	3.970	6.50	66.91	172.46
	5	0.79	6.31	40.0	3.356	6.05	72.03	154.26
		1.18	6.45	41.3	3.732	6.75	68.90	157.17
		1.60	6.53	41.6	3.983	7.28	66.81	164.33
		2.00	6.56	42.6	4.211	8.53	64.91	169.17

of 3 mm and increasing feed rate from 8 kg/h to 12 kg/h seed wastage mass increased from 1.497 kg to 2.703 kg (+80.56 %). Seed wastage mass increased too from 1.497 kg to 2.197 kg (+46.7 %) at a feed rate of 8 kg/h, drum speed of 0.79 m/s and increased clearance between drums from 3 mm to 5 mm.

4. Energy requirement, kWh/Mg:

Table 2 and Fig. 6 show the effect of drum speed, feed rate and clearance between drums on energy requirement. It was observed that increasing drum speed from 0.79 m/s to 2.00 m/s tended to increase energy requirements. Increasing feed rate from 8 kg/h to 12 kg/h or increasing clearance between drums from 3 mm to 5 mm led to decreased energy requirements. A minimum energy requirement was

154.26 kWh/Mg at drum speed of 0.79 m/s, feed rate of 12 kg/h and clearance between drums of 3 mm.

5. Ginning efficiency and gin lint losses percentage

Ginning efficiency and gin lint losses percentage as related to the drum speed, feed rate and clearance between drums are shown in Table 2 and Fig. 7. Increasing drum speed, feed rate and clearance between drums led to decreased ginning efficiency at all experimental points. Also, increasing drum speed and clearance between drums led to increasing gin lint losses percentage and increasing feed rate led to decreased percentage gin lint losses. Through the intersection of curves of ginning efficiency an estimate of the proportion of lint losses can be determined and the optimum con-

ditions for operating the machine, which, then, will be more efficient with less ginning percentage or an acceptable degree of lint losses. And, through the signing of curves graphically it will be possible to identify optimum conditions for operating the machine manufactured with drum speed and feed rate and clearance between the drums. From previous figures the optimum operating conditions for the gin stand developed was at a drum speed of 0.79 m/s, feed rate of 10 kg/h and clearance between drums of 3 mm, where it produced a high value for ginning efficiency equal to 80.69 % and low value of gin lint losses percentage equal 5.19 %, respectively.

6. Total production cost and Criterion Function determination:

Table 3 illustrates the effect of

Fig. 3 Effect of drum speed, feed rate and clearance between two drums on gin stand productivity, kg/h

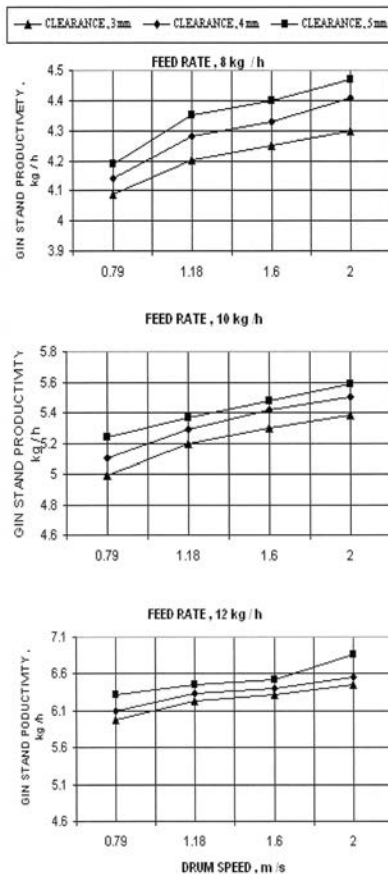

Fig. 4 Effect of drum speed, feed rate and clearance between two drums on lint turn out, %

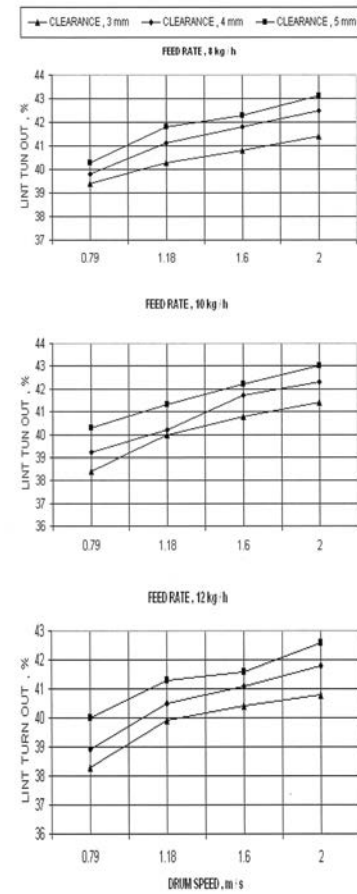

Fig. 5 Effect of drum speed, feed rate and clearance between two drums on seed wastage mass, kg

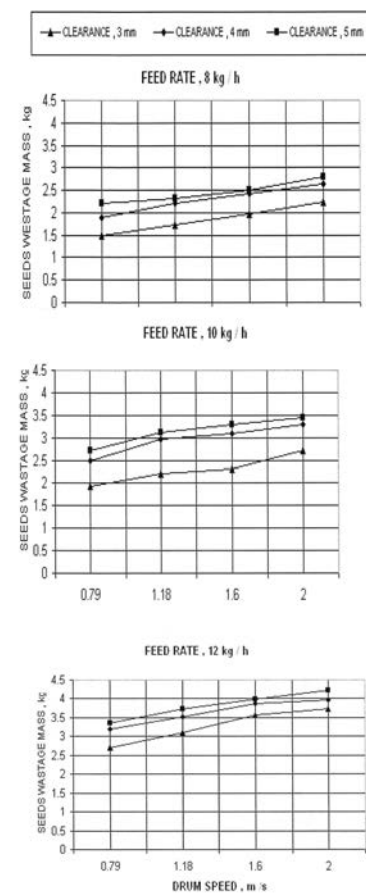

Table 3 Total production cost and Criterion Function Cost for the developed gin stand

Feed rate, kg/h	Clearance between drums, mm / Drum speed, m/s	Total production cost, L.E/Mg			Criterion Function Cost, LE/Mg		
		3 mm	4 mm	5 mm	3 mm	4 mm	5 mm
8	0.79	388.74	384.06	379.5	599.12	660.84	722.42
	1.18	378.57	371.5	365.5	657.75	671.80	757.80
	1.60	374.10	367.2	361.36	683.55	688.27	776.21
	2.00	369.76	360.6	355.70	699.46	722.97	818.57
10	0.79	318.64	311.76	303.40	466.97	482.53	554.40
	1.18	305.77	300.60	285.20	511.82	509.11	555.00
	1.60	300.00	293.30	251.98	520.77	523.20	562.28
	2.00	295.50	289.00	234.40	538.83	543.90	577.63
12	0.79	265.80	261.00	251.90	364.10	399.56	433.76
	1.18	255.20	251.18	246.50	398.62	404.99	451.68
	1.60	251.90	248.00	243.50	419.50	414.78	466.95
	2.00	246.50	242.30	231.40	417.66	437.45	494.80

drum speed on total production cost and criterion function cost at different levels of feed rate and clearance between two drums. The total production cost was decreased with increasing drum speed, increasing feed rate and with increasing clearance between two drums. Vice versa, criterion function was increased at the same previous conditions. On the other hand, criterion function cost was estimated by total cost of all of the operating costs and machine costs in the lint losses and machine costs in the seed damaged. A minimum total production cost was 231.40 LE/Mg recorded at a drum speed of 2.00 m/s, feed rate of 12 kg/h and clearance between

Fig. 6 Effect of drum speed, feed rate and clearance between two drums on energy requirements, kWh/ Mg

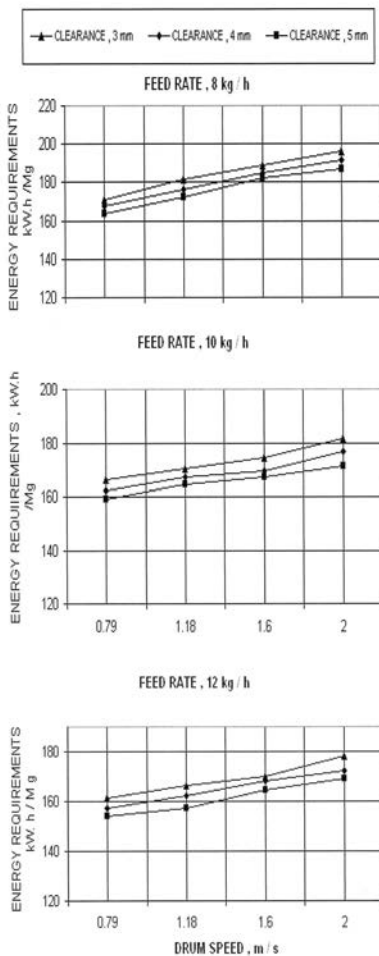

Fig. 7 The relationship between drum speed and both ginning efficiency and gin lint losses percentage at different feed rates and clearance between two drums. (--- ginning efficiency, — % and lint losses, %)

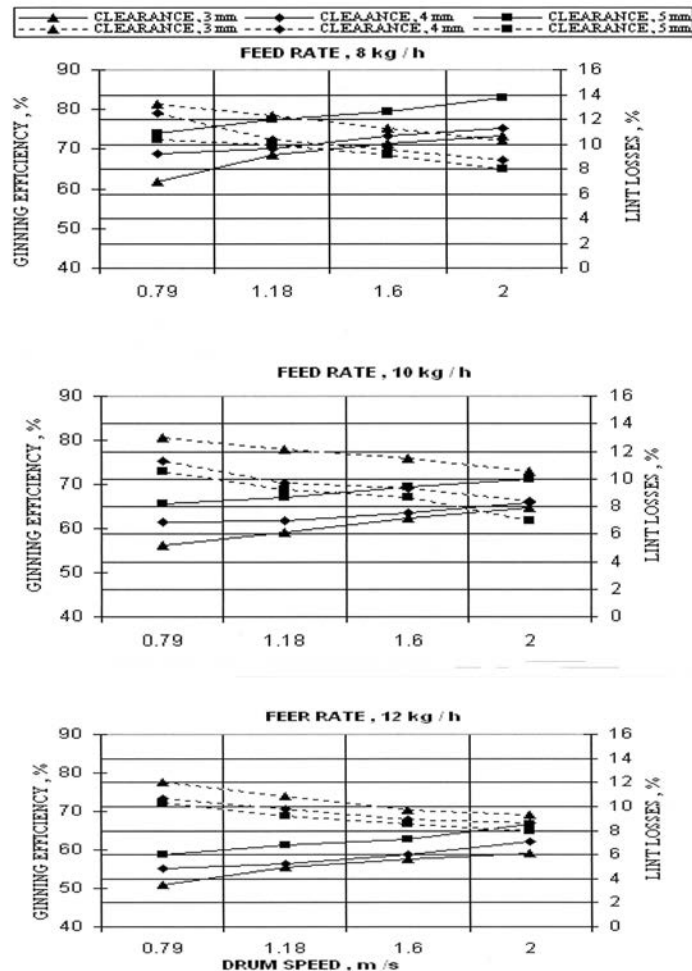

Table 4 The physical fiber quality parameters at optimum operation conditions

Ginning stand machines Fiber quality parameters	The gin stand developed	McCarthy gin roller
Span fiber length 2.5 %, mm	31.1	30.8
Span fiber length 50 %, mm	14.8	14.1
Uniformity ratio, %	47.6	45.8
Fiber reflectance, %	68.0	66.4
Fiber yellowness, unit	6.1	6.5
Fiber strength, g/tex	29.1	28.0
Fiber elongation, %	6.9	7.3

two drums of 5 mm. A minimum amount of criterion function cost was 364.10 LE/Mg recorded at a drum speed of 0.79 m/s, feed rate of 12 kg/h and clearance between two drums of 3 mm, respectively.

Effect of Gin Machine Type on the Physical Fiber Quality Parameters:

Table 4 illustrates the physical properties for fiber quality produced by the developed gin stand and the conventional McCarthy gin roller at optimum operation conditions. Results show that the developed gin stand gave a good outcome compared with the conventional McCarthy gin roller. A high value was recorded of span fiber length 2.5 % (mm), span fiber length 50 % (mm), uniformity ratio (%), fiber reflectance (%) and fiber strength (g/tex). The conventional McCarthy gin roller recorded a high value of fiber yellowness (unit) and fiber elongation (%).

Therefore, the developed gin stand was considered the best for ginning Egyptian seed cotton samples.

Conclusion

It was concluded that: The developed gin stand capacity was directly related with increasing drum speed, feed rate and clearance between drums. Also, the maximum capacity was 6.87 kg recorded at a drum speed of 2.00 m/s, feed rate of 12 kg/h and clearance between drums of 5 mm. Lint turn out percentage was direct-

ly related with increasing drum speed and increased clearance between drums, maximum value of lint turn out was 43.1 % recorded at a drum speed of 2.00 m/s, feed rate of 8 kg/h and clearance between drums of 5 mm.

Seeds wastage mass had a direct relationship with all independent variables. Also, the maximum value of seeds wastage mass was 4.211 kg recorded at a drum speed of 2.00 m/s, feed rate of 12 kg/h and clearance between drums of 5 mm. Gin lint losses percentage was directly related with drum speed and clearance between drums and had a reverse relationship with feed rate. Whereas, the minimum value was 3.5 % recorded at using drum speed of 0.79 m/s, feed rate of 12 kg/h and clearance of 3 mm.

The developed gin stand had maximum value of ginning efficiency of 81.28 % at a drum speed of 0.79 m/s, feed rate of 8 kg/h and clearance of 3 mm.

Minimum value of energy requirement was 154.26 kWh/Mg at a drum speed of 0.79 m/s, feed rate of 12 kg/h and clearance of 5 mm.

Minimum total production cost was 231.40 LE/Mg recorded at a drum speed of 2.00 m/s, feed rate of 12 kg/h and clearance of 5 mm. Minimum Criterion Function Cost 364.10 was LE/Mg with a drum speed of 0.79 m/s, feed rate of 12 kg/h and clearance of 3 mm.

A comparison study between effects of the developed gin stand and McCarthy gin roller on physical fiber quality parameters illustrate

that the gin developed stand could be considered the best for ginning Egyptian seed cotton samples.

REFERENCES

- ASTM, Standards. 1982. Designations: 64(884-96) ASTM, Philadelphia, Pa, USA.
- ASTM, Standards. 1984. Designations: 1445-75. American society for testing and materials. Standards of textile testing and materials. The society, philadelphia, USA.
- Awady, M. N. 1978. Tractors and farm machines, in Arabic, text. Col. Ag., Ain Shams Univ. 164-167.
- Anthony, W. S. 1979. Energy-quality considerations in modeling cotton ginning systems. Transactions of the ASAE. 22(3): 644-648.
- Anthony, W. S. 1985. Effect of gin stands on cotton fiber and seed Cotton. Gin and Oil Mill Press. 86(16): 14-18.
- Anthony, W. S. 1989. Performance characteristics of cotton ginning machinery. American Society of Agricultural Engineers.; Paper No. 89-1010: 26 pp.
- Eweida, M. A., G. A. Morshedi, M. A. Risk, and S. S. Marzook. 1984. Effect of the rotary knife gin-stand adjustment and cleaning the cotton lint on ginning efficiency in some Egyptian and upland cotton varieties. Agric. res. rev. 62(6): 301-311.
- Ezeike, M. S. 1987. Energy requirements for cotton gin machinery. Applied Engineering in Agriculture. 12(3): 455-473.
- Gustafson, R. J. 1980. Fundamentals of Electricity for Agriculture. The AVI publishing company, Inc. Westport, Connecticut.
- Hossam el-din, A. E. 1978. Ginning efficiency as affected by cotton characteristics and some other major factors. Ph.D thesis. Fac. of Agric. Al-azhar Univ.
- Hughs, S. E., M. N. Gillum, and W.

- F. Lalor. 1983. Fiber quality from a combination gin-lint cleaner. American Society of Agricultural Engineers. Paper 83-3533: 15 pp.
- Matouk A. M., Y. M. El-Hadidi, and H. El-Mashad. 1999. Energy accounting and management in some food plants. *Misr Journal of Agric. Eng.* 16 (1): 157-175.
- Mangialardi, G. J. and W. S. Anthony. 2000. Engineering and ginning: feasibility of applying seed cotton cleaning principles to lint cleaning. *Journal of Cotton Science.* 4(3): 183-192.
- May, O. L. and B. C. Bridges. 1995. Breeding cottons for conventional and late planted production systems. *Crop Sci.* 35: 132-136.
- Patil, P. G., S. K. Shukla, and V. G. Arude. 2006. Design development and performance evaluation of portable cotton ginning machines. *AMA*, 37(1): 30-34.
- Rafiq-Chaudhry, M. 1997. Harvesting and ginning of cotton in the world. *Proceedings Beltwide Cotton Conferences*, New Orleans, LA, USA, January, 1997, Volume 2: 1617-1619.
- Whitelock, D. P, C. B. Armijo, G. R. Gamble, and S. E. Hughs. 2007. Survey of seed-cotton and lint cleaning equipment in U.S. roller gins. USDA-ARS Southwestern Cotton Ginning Research Lab, 300 E College. *Journal of Cotton Science.* 2007. 11(3): 128-140. ■■

BOOK

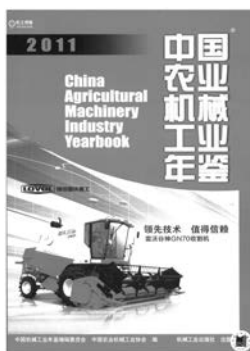

"China Agricultural Machinery Industry Yearbook 2011"

Publisher : China Machinery Industry Press

This is an efficient book to set annual review, industry overview, mechanical profiles, projects and products, statistics, policies, regulations and standards, events and appendix section, a comprehensive system to reflect the mechanization of agricultural machinery industry and developments in each areas. We provide readers with a more complete and accurate statistics. In recent years, the state has increased the intensity of agriculture in 2009, four billion yuan financial allocations for agricultural machinery purchase subsidies. Subsidies on the agricultural sector had a significant impact. For example, in 2010, there was a significant increase of annual agricultural subsidies in particular content for industry research analysts.

This book is the main target for government policy-making institutions, decision makers and agricultural machinery-related businesses engaged in market analysis, middle management, business planning and foreign investment institutions, trading companies, banks, securities, advisory services and research Agricultural project management unit.

Contents

Overviewing the Development of Agricultural Machinery Manufacturing Industry / Overviewing the Development of Agricultural Machinery Science and Technology Progress / A survey of the quality of agricultural machinery products / Import and Export of Agricultural Machinery in 2010 / Import and Export of Agricultural Machinery in 2010 / Situation of Agricultural Machinery Purchasing Subsidies in 2010 / Circulation of Chinese Agricultural Machinery

"Management of Drip/Trickle or Micro Irrigation"

Author: Dr. Megh R. Goyal

Senior Acquisitions Editor, Biomedical Engineering and Agricultural Science, Apple Academic Press, Inc.

This important book-the only complete, simple, one-stop manual on microirrigation worldwide-offers knowledge and techniques to develop and manage an effective and efficient drip/trickle or micro irrigation system.

"Management of Drip/Trickle or Micro Irrigation" includes the basic considerations relating to soil-water-plant interactions, with topics such as methods for soil moisture measurement; evapotranspiration; irrigation systems; tensiometer use and installation; principles of drip/ micro/ trickle irrigation; filtration systems; automation; chloration; service and maintenance; design of drip irrigation and lateral lines; the evaluation of uniformity of application; and an economical analysis for selecting irrigation technology.

About The Author: Dr. Megh Raj Goyal obtained his BSc degree from Punjab Agricultural University, Ludhiana, India. He obtained his MS and PhD degrees from Ohio State University, USA. At present, he is a retired professor at the University of Puerto Rico. He is also Senior Acquisitions Editor for Apple Academic Press, Inc., in the areas of agricultural/biological engineering and bioengineering/biomedical engineering/ biotechnology. He has published more than 200 technical articles in professional journals, a textbook on the elements of agroclimatology, conference proceedings on biomechanics, and two bibliographies on micro irrigation. A professionally licensed engineer, he is known as the "Father of Irrigation in Engineering" in Puerto Rico.

This announcement is abstracted from Apple Academic Press, Inc.

e-mail: info@appleacademicpress.com <http://www.appleacademicpress.com>

Technological Change in Paddy Production: A Comparative Analysis of Traditional and Direct Seeding Methods of Cultivation



by
Radhey Shyam Singh

Principal Scientist (Agril Economics) & Project Coordinator (ESA)
Central Institute of Agricultural Engineering, Nabibag, Berasia Road, Bhopal-462038
INDIA
rssingh12@gmail.com

L. P. Gite

Abstract

The quantitative analysis of agricultural production systems has become an important step in the formulation of agricultural policy. A number of empirical studies have attempted to investigate producer responsiveness to product and input price changes, to estimate economies of scale, to assess the relative efficiency, and to measure the impact of technological change. In particular, there has been a considerable amount of theoretical and applied econometric research on the measurement of the impact of technological change. The recent breakthrough in rice cultivation known as direct seeding technology through TNAU eight rows Improved Direct Paddy Seeder (popular as Drum Seeder) is one such case, which may be considered as potential technology. In direct seeding technology, synergic interaction increases land, labour and water use efficiency. Direct seeding technology deviates from the traditional method of cultivating irrigated paddy in a number of ways. For instance, 8 kg/

ha of seed is insufficient as against the usual 70 kg/ha in traditional method. Keeping this in view the present study was proposed with the objectives to: (i) compare and contrast the cost and returns of paddy cultivation in traditional technology and the new technology of direct seeding method and (ii) measurement of resource use efficiency of paddy cultivation in traditional technology and the new technology of direct seeding method. Data were collected from a representative sample of 60 growers using 8 row TNAU improved direct paddy seeder (locally called Drum Seeder) and 30 growers using manual transplanting of paddy in different villages of Pudukkottai and Tiruchirappalli districts of Tamil Nadu during the year 2008-09. The resource use efficiency was assessed by comparing marginal value product (MVP) with factor cost of the resources. The marginal product (MP) was estimated from the parameters of multiple linear production function. The average net returns were Rs. 15,600/ha and Rs. 41,300/ha in traditional and direct seeding methods

of paddy cultivation. The yield realised in the traditional method was 5.60 tonnes per ha and it was 6.80 tonnes per hectare in direct seeding method. The cost of cultivation in the traditional method (Rs. 40,960/ha) was more when compared to that in direct seeding method (Rs. 30,102/ha). The estimated production functions were significant with high R^2 for both the direct seeding method and traditional methods. The output elasticity coefficients for seeds, labour, fertiliser, FYM and miscellaneous were positive and statistically significant in both the methods except seed that was not found significant in case of traditional method. There was a structural break up between the two production functions. The MVP-MFC ratios in traditional methods indicated that there was a scope for increased use of seeds in the short run keeping the use of other resources at a constant level. This was also true for fertiliser, FYM and miscellaneous items including plant protection chemicals as MVP-MFC ratio for these resources was also more than one. On the other hand, the farm-

ers under the direct seeding method could maximise their profit by using more quantities of seeds, fertilisers, FYM and miscellaneous items including plant protection chemicals as the MVP-MFC ratio for all these resources was more than one. It has also worked out that the major component of the productivity difference was due to the difference in method of cultivation. The findings of this study demonstrate the superiority of direct seeding technology in terms of yield and returns advantage. However, it is worth mentioning here that the actual adoption rate of direct seeding technology among paddy growers is low, which appears to be a puzzle given the encouraging performance of the new technology. These observations call for enhanced extension services for popularising the direct seeding technology. The timely guidance to the farmers from the extension agencies and to the persons involved in the transfer of technology to the farmers' field would be an immense help in this direction.

Introduction

Paddy is the principal crop extensively cultivated in all the districts of the Tamil Nadu having a unique three-season pattern viz Kar/Kuruvai /Sornavari (April to July), Samba/ Thaladi/Pishanam (August to November) and Navarai/ Kodai (December to March). In 2008-09, the area under paddy cultivation in

the state increased to 2.34 lakh hectares as against 2.28 lakh hectares in 2007-08. Besides, the total production of paddy and productivity have also increased in tandem. Though it is only a marginal increase, it will create a great impact on the paddy cultivation of the state. The fallow land cultivation projects have helped to create a new wave among the farmers. Acres of paddy field, which had been kept barren for decades, have been brought under cultivation.

The quantitative analysis of agricultural production systems has become an important step in the formulation of agricultural policy. A number of empirical studies have attempted to investigate producer responsiveness to product and input price changes, to estimate economies of scale, to assess the relative efficiency, and to measure the impact of technological change. In particular, there has been a considerable amount of theoretical and applied econometric research on the measurement of the impact of technological change. The recent breakthrough in rice cultivation known as direct seeding technology through Improved Direct Paddy Seeder (popular as Drum Seeder) is one such case, which may be considered as potential technology. In direct seeding technology, synergic interaction increases land, labour and water use efficiency. Direct seeding technology deviates from the traditional method of cultivating irrigated paddy in a number of ways. For instance, 20 kg/ha of seed

is insufficient as against the usual 70 kg/ha in the traditional method. Keeping this in view, the present study was proposed with the objectives to: (i) compare and contrast the cost and returns of paddy cultivation in traditional technology and the new technology of direct seeding method and (ii) measurement of resource use efficiency of paddy cultivation in traditional technology and the new technology of direct seeding method.

Methodology

The study was based on the input-output data from sample paddy growing farmers in Pudukkottai and Tiruchirapally districts of Tamil Nadu selected purposively as per the suggestions of technology innovator. Ninety farmers (60 farmers growing paddy by Drum Seeder technology and 30 farmers growing paddy by traditional method/manual transplanting) spread over 6 villages of selected districts were interviewed during March 2009. The data on various inputs used in paddy cultivation like chemical fertilizers, plant protection chemicals, seed materials, human labour, and cultivation practices such as land preparation, transplanting/sowing, irrigation, inter-cultivation and harvesting along with labour requirement for these operations were collected from the sample farmers on specific proforma developed for the purpose. A photograph of Improved

Fig. 1 A view of Improved Direct Paddy Seeder in working condition



Figs. 2 and 3 A view of commercial manufacturing unit M/S KSNM, Coimbatore (India)



Direct Paddy Seeder in working condition at the farmer's field is given in **Fig. 1**.

The Improved Direct Paddy Seeder is commercially manufactured by M/S KSNM, Coimbatore (India) and a view of manufacturing unit is given in **Figs. 2 and 3**.

Analytical Framework

The costs, returns and profits in traditional and drum seeder methods of paddy cultivation computed on per hectare basis were compared. The cost of human labour was estimated in terms of 8 man hours the women labour days were converted into man-days considering one women day as being equal to 0.60 man-day based on the prevailing wage rates in the study area. The costs of bullock and machine labour both, owned and hired, were calculated at the prevailing rates. The costs of farm produced seeds and farmyard manure (FYM) were imputed at the market price in the village including the cost of transportation and other incidental charges, if any. The costs of purchased seeds, fertilisers and plant protection chemicals were calculated based on the actual expenditure incurred. The amount fixed by the government for irrigation and land revenue was considered for computation of these costs. The rental value of land was imputed based on the prevailing rents in the study area. The short term (9 percent) and long term (12 percent) bank lending rates were used to work out the interest on working and fixed capital respectively. The depreciation was calculated by the straight line method. The charges on account of minor repairs of implements and machinery during the year were added to the depreciation charges. The interest on fixed capital and depreciation were apportioned on the basis of area of land under each crop grown during the year. The gross returns were computed by multiplying the quantity of main product and

by-products with respective prices received.

The resource use efficiency was assessed by comparing marginal value product (MVP) with factor cost of resources. Decomposition analysis was used to measure the contributions of technology and resource use differentials to the total productivity differences between traditional and drum seeding methods of paddy cultivation.

$$Y = A + b_1X_1 + b_2X_2 + b_3X_3 + b_4X_4 + b_5X_5 + u$$

where,

Y = output in quintal/ha,

X₁ = seed in kg/ha,

X₂ = human labour in mandays/ha,

X₃ = fertiliser in kg/ha,

X₄ = farm yard manure in t/ha,

X₅ = plant protection chemicals and miscellaneous in Rs./ha,

u = Error term.

The miscellaneous expenditure in the model included the expenditure on bullock, tractor, electric motor, irrigation charges, land revenue and rent, interest on working and fixed capital and depreciation.

By using the subscripts 'd' and 't' respectively to represent production functions of drum seeding and traditional methods of paddy cultivation, the difference in output between the drum seeding and traditional methods of paddy cultivation may be written as

$$(Y_d - Y_t) = (A_d - A_t) + \sum_{i=1}^5 (b_{di} \times X_{di} - b_{ti} \times X_{ti})$$

Adding and subtracting $\sum_{i=1}^5 (b_{di} \times X_{ti})$ in the above equation and rearranging the terms yields the following decomposition model can get

$$(Y_d - Y_t) = (A_d - A_t) + \sum_{i=1}^5 (b_{di} - b_{ti}) \times X_{ti} + \sum_{i=1}^5 b_{di} (X_{di} - X_{ti})$$

To examine whether the parameters of the production functions defining the two methods of rice production were different, which was an essential component of decomposition analysis, a dummy variable was introduced into the linear production function, which was

specified as follows:

$$Y = A + b_1X_1 + b_2X_2 + b_3X_3 + b_4X_4 + b_5X_5 + D + u$$

Where, Y, X₁, X₂, X₃, X₄, X₅ and U are as defined earlier and D = Dummy variable which takes value 1 if it is Drum Seeding method and value 0 otherwise.

Results and Discussion

Cost and Returns in Traditional and Direct Seeding Methods

The profitability of direct seeding method of paddy cultivation in the study area was analysed by computing per hectare cost and returns and comparing them with those of the traditional method. The pattern of inputs used in both the methods of paddy cultivation for sample farmers is presented in **Table 1**. The quantities of seed, nitrogen, phosphorus, potash, plant protection chemicals, human labour and bullock labour used in traditional method of paddy cultivation were 70 kg, 92 kg, 74 kg, 84 kg, 1934 ml, 167.18 man-days and 18 pair-days respectively, which were larger than the quantities of 20 kg, 81 kg, 62 kg, 72 kg, 1,022 ml, 127.04 man-days and 9 pair-days correspondingly in direct seeding method.

Tractor and electric motor use were also high in traditional method as compared to the direct seeding method. It may be noted that direct seeding method by the Drum Seeder equipment involves careful sowing of pre-germinated seed and 1 to 2 inter-cultivation/weeding by the Cono Weeder. The per hectare cost of cultivation in traditional method (Rs. 40,960) was more when compared to that in direct seeding method (Rs. 30,102). The share of human labour cost in total cost was 40.77 percent in traditional method and 42.18 percent in direct seeding method. The contribution of machine labour (tractor plus electric motor) total cost was 10.35 percent in the traditional method

and 9.42 percent in direct seeding method. Fertilisers were the next important item of expenditure in both the methods of paddy cultivation which worked out to be 7.70 percent and 8.97 percent of total cost, respectively, in traditional and direct seeding methods. The amount spent on farmyard manure (Rs. 859) was higher in the case of the traditional method as compared to that in the direct seeding method (Rs. 804). There was a glaring difference in the costs incurred on seeds between the two methods mainly due to smaller quantity of seeds used in the direct seeding method. The considerable difference in plant protection chemicals between traditional method (Rs. 2,667) and direct seed-

ing method (Rs. 1,170) was due to the fact that the incidence of pests in the study area was less in the direct seeding method.

The majority of paddy growers of direct seeding method used certified seed from the market and those seeds had resistance from pests. The rental value of land was also a major item of expenditure contributing to the fixed cost (14.65 percent and 19.93 percent, respectively, in traditional and direct seeding methods). The share of variable cost in the total cost was 83.13 percent (Rs. 34,048) in the traditional method and 77.06 percent (Rs. 22,198) in the direct seeding method. As such, variable cost was less by about Rs. 10,850 in the direct seeding method when

compared to the traditional method.

The yield realised in the traditional method was 5.6 tonnes per hectare, while it was 6.8 tonnes per ha in the direct seeding method. The yield difference was mainly because of more productive tillers per m² in the direct seeding method. The growth of more productive tillers in the direct seeding method was due to the interculture/weeding by the Cono weeder that provided sufficient aeration to the root zone of the paddy plants. The net returns per hectare was much higher in the direct seeding method (Rs. 41,298) as compared to the traditional method (Rs. 17,839). This was mainly due to higher gross returns (Rs. 71,400) in the direct seeding method, where

Table 1 Per hectare input and output in traditional and direct seeding methods

Particulars	Units	Traditional method		Direct seeding method	
		Quantity	Value	Quantity	Value
A: Variable cost					
Seed	kg	70	1,540 (3.76)	20	440 (1.46)
Fertilizer					
Nitrogen	kg	92.00	1007 (2.45)	81.00	886 (2.94)
Phosphorus	kg	74.00	1477 (3.60)	62.00	1237 (4.11)
Potash	kg	84.00	672 (1.64)	72.00	576 (1.91)
Farmyard Manure	tonne	3.45	859 (2.09)	3.23	804 (2.67)
Agro-chemicals	ml	1934.00	2667 (6.51)	1,022.00	1,170 (3.89)
Human labour	Man-days	167.18	16,700 (40.77)	127.04	12,700 (42.18)
Bullock labour	Pair-days	18.00	3,600 (8.80)	9.00	1,800 (5.98)
Machine labour					
Tractor	hour	8.37	2929 (7.15)	5.20	1820 (6.05)
Electric motor	hour	88.00	1,312 (3.20)	68.00	1,016 (3.37)
Interest on working capital	Rs.		1,171 (2.85)		625 (2.08)
Irrigation charges	Rs.		113 (0.28)		123 (0.41)
Total variable cost	Rs.		34,048 (83.13)		23,198 (77.06)
B Fixed cost					
Land revenue	Rs.		22 (0.05)		23 (0.08)
Rental value of land	Rs.		6,000 (14.65)		6,000 (19.93)
Depreciation	Rs.		345 (0.84)		383 (1.27)
Interest on FC	Rs.		544 (1.32)		498 (1.65)
Total fixed cost	Rs.		6,912 (16.87)		6,904 (22.93)
C: Total cost	Rs.		40,960 (100)		30,102 (100)
D: Yield					
Main product	tonnes		5.6		6.8
By product	tonnes		4.43		5.1
E: Gross return	Rs.		58,800		71,400
F: Net returns	Rs.		17,839		41,298
G: Benefit-Cost Ratio			1.44		2.37

(Figures in parentheses indicates percentage to total cost)

paddy yield harvest was more. The returns per rupee spent in the traditional method were Rs. 1.44 against Rs. 2.37 in direct seeding method. These findings clearly indicated that the direct seeding method was a better yielding technology. The difference in the use of most of the inputs between the two methods were evident. Direct seeding technology demanded less input as compared to the traditional method of paddy cultivation. Therefore, promotion of direct seeding technology could result in substantial yield gain and efficient use of scarce resources. A view of a paddy crop field sown by Improved Direct Paddy Seeder is given in **Fig. 4**.

Resource Use Efficiency of Paddy Cultivation

In order to test the difference in the structural relationship in the parameters defining the production functions for the two methods, the linear production function with both intercept and dummy was estimated. The estimated production parameters are presented in **Table 2**. The estimated production function explained 92.9 percent variation in paddy output due to variation in all the resources put together showing a good fit of the model. The coefficient of the dummy was significantly different from zero. This result facilitated the rejection of the hypothesis that production parameters defining the drum seeding method and the traditional method were the same. The positive estimates of in-

Fig. 4 A view of paddy crop field sown by Improved Direct Paddy Seeder



Table 2 Estimated production functions

Particulars	Production elasticity		
	Pooled	Traditional	Drum seeding
Intercept	8.50 (6.706)	13.803* (7.369)	11.677*** (4.761)
Seed	0.098 (0.127)	0.044 (0.122)	0.832*** (0.298)
Human labour	0.046* (0.026)	0.048* (0.028)	0.067*** (0.040)
Fertiliser	0.093*** (0.018)	0.043* (0.025)	0.072*** (0.024)
Farm yard manure	1.051*** (0.230)	0.519* (0.296)	0.910*** (0.346)
Miscellaneous	0.001*** (0.000)	0.002** (0.001)	0.001** (0.000)
Dummy	13.092*** (5.421)	-	-
R ²	0.929	0.924	0.937
F-value	49.442	27.95	67.415

(Figures in parentheses are standard errors)

*, ** and *** significant at 10, 5 and 1 percent level, respectively.

tercept and dummy coefficients for all resources implied that the output in drum seeding method was significantly higher than that in the traditional method for a given level of resources. They also implied larger elasticity coefficients of production with respect to each input under the drum seeding method compared to traditional method. This result, as such, offered the required justification for decomposing the factors contributing to productivity difference between the drum seeding and traditional methods of paddy cultivation.

For decomposing the productivity difference between drum seeding and traditional methods of paddy cultivation, the parameters of the per hectare production functions and the mean levels of input use for the two methods were essential. Hence, the production functions for drum seeding and traditional methods were also estimated separately. As much as 92.4 and 93.7 percent of variation in paddy output, respectively, in traditional and drum seeding methods was explained by the independent variables. The coefficients of constant term (intercept) in both the cases were found significant. The production elasticity coefficients of seeds, labour, fertilisers, FYM and expenditure made on miscellaneous items were positive and significant in drum seeding method while all the production coefficients except seed were found positive and

significant in traditional method. The output elasticity coefficients of seed, human labour, fertilizer and FYM in the case of the drum seeding method were relatively greater as compared to those for the traditional method. The paddy output in the traditional method increased by 0.519 percent and 0.043 percent for every one percent increase in the use of FYM and fertilizer. Thus, the major contribution to output in the traditional method came from FYM and fertilizer. In the case of the drum seeding method, the paddy output would increase by 0.910 percent, 0.832 percent and 0.072 percent for every one percent increase in the use of FYM, seed and fertilizers. Thus, the major contribution to output in drum seeding method came from FYM, seed and fertilizers, **Table 2**.

To analyse the scope for intensification of resources in both methods, the marginal value product (MVP) of the resources was compared with the respective marginal factor costs (MFC). The MVP and MFC ratios for different resources for both the methods are given in **Table 3**. The MVP-MFC ratios in traditional method indicated that there was a scope for increased used of seeds in the short run keeping the use of other resources at a constant level. This was also true for fertiliser, FYM and miscellaneous items as MVP-MFC ratio for these resources was also more than one. Nevertheless,

MVP-MFC ratio for labour was less than one and a positive indicator that profit could be maximized in the short run by using less labour. On the other hand, the farmers under the drum seeding method could maximize their profit by using more seed, labour, fertilizer, FYM and miscellaneous item as the MVP-MFC ratio for all these resources was more than one.

Using the decomposition of output difference between the drum seeding and the traditional method was decomposed into its constituent sources and the results are presented in **Table 4**.

A perusal of the results of decomposition analysis revealed that there was a sizeable discrepancy between the observed difference (13.40 percent) and the estimated difference (15.63 percent) in the productivity of drum seeding and traditional method. It can further be inferred that between technological and input use differentials, which together

contributed to the total productivity difference of the order of 13.40 percent, the farmer alone accounted for 47.37 percent. This implied that the paddy productivity could be increased by about 47.37 percent if the farmers could switch over from the traditional method to the drum seeding method with the same level of resources used as in the traditional method.

Conclusions

The average net returns were Rs. 15,600/ha and Rs. 41,300/ha in traditional and direct seeding methods of paddy cultivation. The yield realised in the traditional method was 5.60 tonnes per ha and it was 6.80 tonnes per hectare in the direct seeding method. The cost of cultivation in the traditional method (Rs. 40,960/ha) was more when compared to that in the direct seeding method (Rs. 30,102/ha). The estimated production functions were significant with high R^2 for both the direct seeding method and traditional methods. The output elasticity coefficients for seeds, labour, fertilizer, FYM and miscellaneous were positive and statistically significant in both the methods except seed that was not found significant in the case of the traditional method. There was a structural break up between the two production functions. The MVP-MFC ratios in the traditional methods indicated that there was a scope for increased use of seeds in the short run keeping the use of other resources at a constant level. This was also true for fertilizer, FYM and miscellaneous items including plant

protection chemicals as MVP-MFC ratio for these resources was also more than one. On the other hand, the farmers under the direct seeding method could maximise their profit by using more seeds, fertilizers, FYM and miscellaneous items including plant protection chemicals as the MVP-MFC ratio for all these resources was more than one. It has also worked out that the major component of the productivity difference was due to the difference in method of cultivation. The findings of this study demonstrate the superiority of direct seeding technology in terms of yield and returns advantage. However, it is worth mentioning here that the actual adoption rate of direct seeding technology among paddy growers is low, which appears to be a puzzle, given the encouraging performance of the new technology. These observations call for enhanced extension services for popularising the direct seeding technology. The timely guidance to the farmers from the extension agencies and to the persons involved in the transfer of technology to the farmer's field would be of immense help in this direction.

REFERENCES

- Palanisami, K. P. Permasivam and C. R. Ranganathan. 2002. *Agricultural Production Economics: Analytical Methods and Applications*, Associate Publishing Company, New Delhi.
- Sankhyan, P. L. 1988. *Introduction to Economics of Agricultural Production*. Prentice Hall of India Private Ltd, New Delhi. ■■

Table 4 Decomposition of output difference between the drum seeding and the traditional methods

Source of output difference	% Contribution
Observed difference in output	13.40
Source of contribution	
Due to difference in technology	47.37
Due to difference in input use	-31.74
Seed	-33.26
Human labour	-3.38
Fertiliser, Farm yard manure, Miscellaneous	-0.19, 2.02 & 3.08
Estimated difference in output	15.63

Table 3 MVP and MFC of resources in traditional and drum seeding methods

Inputs	Traditional			Drum seeding		
	MVP	MFC	Ratio	MVP	MFC	Ratio
Seed (kg)	46.2	12.46	3.71	1,268.80	16.50	76.90
Labour (man days)	50.4	90.00	0.56	90.45	90.00	1.01
Fertiliser (kg)	45.15	12.50	3.61	97.20	12.50	7.776
FYM (tonnes)	544.95	205.00	2.66	1,228.50	211.00	5.82
Miscellaneous (Rs.)	2.10	1.00	2.10	1.35	1.00	1.35

New Mechanical Picking Head for Peach Harvesting

by

A. H. Soliman

M. E. El-Iraqi

S. E. El Khawaga

T. R. Awais

Agricultural Engineering Reserchar Institute, Agricultural Research Center, Egypt Researchers, EGYPT

Abstract

Two mechanical harvesting prototypes with an electrical picking hook and electrical picking holder were designed and fabricated for picking peaches as a simple low cost picking head that assured fair fruit quality with minimal damage. The effect of using it on the picker performance and productivity was evaluated. This required two experiments to evaluate the designed prototypes. The first one was to study the effect of using designed mechanical heads for picking Early Grand and Meet Ghamr varieties compared with traditional peach picking methods (hand hook and hand picking). The other experiment was to study the effect of using five different pickers (labors) to pick Meet Ghamr peaches from upper and lower parts of the peach tree layers by the mechanical and manual picking methods under study.

The results led to the following conclusions: the picker productivity using the electrical picking hook increased by about (91.32, 146.92, and 46.30 %) compared with labor productivity using the electrical picking holder, manual picking hook and hand picking, respectively, as an average percentage. The electrical picking hook gave the lowest values of damaged fruit percentage (1.0 %) and the highest value of good quality fruit percentage 96 % (extra fancy –grade 1) compared

with electrical picking holder, manual picking hook and hand picking method, consequently, increasing the rate of fresh market exporting, in addition to reducing picking cost and increasing national income.

Introduction

Egypt stands among the largest peach producing countries in the world and occupies the 11th rank in production amongst the 17 producing countries. Egyptian peaches have a relative advantage in terms of early ripening and nearness to international import markets, in addition to yield, fruit quality and relatively low labor cost. Consequently, this creates a unique situation that favors Egypt as a potential exporter for fresh market peaches especially to European and Arabic Gulf countries in April and May every year due to early ripening before other competing countries. Therefore, the exported quantities of peaches have been generally increasing. For these reasons, the total area of peach production in Egypt increased from 27,000 fed. in 1982 (69,000 tons) to 78,494 fed. in 2001 (224,183 tons) and 83,703 fed. in 2007 (420,273 tons). The success of peach planting in new reclaimed lands in the north of Sinai Governorate (rainy planting) represents about 80 % of the total area of peaches in Egypt where the average yield was about 3-4 ton/

fed compared to 8-12 ton/fed in irrigated old lands (E. A. S., 2008).

Horsfield *et al.* (1972) studied the optimization of mechanical harvesting procedures for apricots of non-uniform maturity. It was concluded that, for the orchard conditions investigated, selective tree harvesting was more profitable than hand harvesting but the once-over harvesting method was not as profitable as hand harvesting, especially for large orchards. They stated that a combination of hand harvesting to remove the more mature tip fruits, followed by machine harvesting, might have potential and should be evaluated.

Sims *et al.* (1973) described an integrated system of growing, harvesting and handling peaches using growth regulators, a mechanical harvester, and a portable field dumper-sorter capable of applying fungicides, which would make it possible to deliver acceptable quality fresh-market peaches. They identified cuts which led to fruit rot development during storage as the most serious problem related to mechanical harvesting. However, encouraging results on mechanical harvesting of peaches for fresh market have been reported by (Kunz *et al.*, 1975). Bruising due to impacts, which may be manifested internally in the flesh, is a major limiting factor for harvest mechanization in fresh-market peaches.

Zocca and Fridly (1977) indicated that the limitations to mechanical

harvesting of peach fruits include bruising, variation in fruit maturity, low tree profiles, damage tree trunk and limbs from shaker action. However, with proper management of the harvesting operation, clingstone peaches can be successfully harvested mechanically. In 1980 about 35 % of the clingstone peach crop in California was harvested mechanically. Since bruising can be higher in mechanically harvested fruits, they should be processed soon after harvested in order to minimized fresh browning, (Kader, 1980).

Sansavini *et al.* (1982) conducted a mechanical harvesting trial using a mechanical harvester prototype from Bologna University, specially designed and tested for harvesting apricots and prunes. Their tests showed that the use of the mechanical harvester resulted in an average loss of 15 % of the fruit, but the harvester offered high working speed and manpower saving.

Kader (1983) studied the influence of the harvesting methods on quality of deciduous tree fruit and his results concluded that the continuing consumer demands for high flavor-quality fresh fruits indicated the need for picking fully ripe fruit that cannot be mechanically harvested without serious damage. The success of future research efforts in developing mechanical-harvesting systems will require continued cooperation between horticulturists and agricultural engineers. Research by horticulturists should emphasize modification in the production systems of deciduous tree fruits. Research by agriculture engineers should continue to improve fruit detachment and collection systems to minimize mechanical injuries to fruits and trees.

Sansavini and Costa (1986) conducted research on mechanical harvesting and pruning of apricot trees. They found that manual harvesting of the bigger and more appealing fruits was necessary for the fresh market and with the remaining ones

harvested by shaker for the processing industry.

Zocca *et al.* (1991) described technical data and performance of a fully automated fruit harvester. The single unit fully automatic fruit harvester featured ultrasound, magnetic and mechanical sensors fed input data to a proportional linear controller and hydraulic system that, sequentially, ran all harvesting operations, including trunk positioning. Only one person was needed to operate the unit and over 80 trees/h could be harvested.

Sarig (1993) concluded that mechanization of the fruits harvesting, and primarily of those destined for the fresh market, was still a manual task and highly desirable in many countries due to the decrease in seasonal labor availability. Some of the technology existed for harvesting fruit intended for processing, but its utilization for soft, fresh fruit was limited because of the excessive mechanical damage to the fruit during mechanical harvesting. Also, all mechanical harvesting today is based on once-over harvesting with no provisions for selective harvesting; a quite common requirement for many fruit crops.

Horvath and Sitkei (2001) proposed a new tree model which analyzed three different kinds of trunk motion. Based on acceleration measurements in the soil body, a new mass component was included in addition to the common mass components. An analysis of dynamics and power requirement of the system has shown that the elastic deformation of the trunk will continuously be higher as attachment height increases, resulting in a significant decrease in the net power requirement.

Erdogan *et al.* (2003) designed and constructed an inertia type hydraulically powered limb shaker and driven by the tractor power take-off, for mechanical harvesting of apricots. In the tests, the limbs were shaken at 20, 30, 40, 50 and 60 mm

amplitude of the connecting rod attached to the crankshaft at 10, 15 and 20 Hz frequencies for optimum shaking time. The shaking time, frequency and amplitude for a limb were found to be 5 s, 15 Hz, and 40 mm, respectively. Limb position, limb length and tree size affected the fruit removal percentage at the 5 % significance level. The least fruit damage was obtained with the plastic canvas catching surface. The time required to harvest an apricot tree by hand and by traditional and mechanical harvesting methods were 400, 20, and 6 min, respectively. The inertia type limb shaker showed great promise and did not cause any damage to the limb and bark.

Sanders (2005) reported that the most difficult aspect was the selection and removal of the individual pieces of fruit from the tree. None of the currently available mechanical harvesting systems have been able to fully replace the flexibility and fruit selection abilities of manual pickers. Most of them only have crop selection capacity. These harvesters were designed to remove all of the current season fruit from the tree during the first picking operation. Picking the fruit in one operation has the disadvantage that it results in a portion of the fruit picked not being of optimum quality, because some of the less mature fruit on the tree will not have reached optimum quality and some of the more mature fruit will have begun to deteriorate. Hence, the maximum achievable financial return was heavily dependent upon the fruit quality distribution on the day of picking.

Polat *et al.* (2007) used an inertia type limb shaker, hydraulically powered and driven by the tractor power take-off, for mechanical harvesting of pistachio nuts. The limbs of trees were shaken at 40, 50, 60 mm amplitude of the connecting rod attached to the crankshaft and 10, 15, 20 Hz frequencies. Shaking time

was 10 s for all of the frequency and amplitude tests. Maximum fruit removal (100 %) was achieved by operating the shaker at an amplitude of 60 mm and a frequency of 20 Hz. Tree structure was the most significant factor influencing the success with mechanical harvesting of fruits.

Torregrosa *et al.*, (2008) designed and constructed catching systems to pick peaches detached from the trees by shaking with hand-held shakers. The experiments were carried out on a crop of peaches (cv. Caterina). Three catching systems were tested: A) a pair of canvases, B) a catching trailer with extendable flat planes, and C) a pair of canvases with direct discharge to boxes. Their results indicated that fruit detachment percentage with the hand-held shakers ranged between 83 % and 95 %. Less than 2.4 % of the fruits were severely injured. Harvesting rates per operator increased from 100 kg/h with hand harvesting to nearly 200 kg/h with systems A and B and to more than 300 kg/h with system C. System C was also tested

to harvest fresh market peaches (cv. Tardivel), but 13 % of the fruits were damaged to some extent (severe and slight) and this was not acceptable for the producers.

Problem Statement

Several of the current mechanical harvesters have been able to reduce the labor requirement and greatly increase the picking rate above that which could be achieved by manual pickers. Moreover, for realizing the economic importance of the Egyptian peach fruit and the advantages of individual fruit harvest over mass removal done by different mechanized techniques, in addition to overcoming the shortage of labor supply for hand harvesting, our research has been directed toward finding an efficient mechanized picking method to harvest peaches for fresh market, reducing labor requirement and maximizing manual picking productivity and fruit quality in order to minimize total harvesting costs and increase the exporting rates for peaches. Therefore, the aim of this study was to design and fabricate a small scale peach

picking head prototype of a simple low cost picking head that assures having fair fruit quality with minimal damage and evaluate the effect of using it on picker performance.

Material and Methods

In this study, two designed prototypes of harvesting tools namely the electrical picking hook and electrical picking holder were evaluated under field harvesting conditions. The fabrication of these prototypes was carried out at the same private workshop in El-Mansoura and Damnhour cities, Egypt, in 2007. The construction and the main components of both types of harvesting heads could be explained as follows:

Peach Electrical Picking Hook

The prototype peach electrical picking hook was constructed from the following main parts as indicated in Fig. 1.

A telescopic carrier that consisted of two hollow aluminum pipes 3 m long. The upper one ($\phi = 16$ mm) was inserted into the lower one ($\phi = 20$ mm) to adjust the height of peach electrical picking hook.

The picking mechanism consisted of a linear DC motor, 12 V - 70 Ah, hook shaft, retraining spring, picker shaft guide and picker hook. The DC motor was fixed on the upper end of the telescopic carrier, while the hook shaft was fixed inside the magnetic coil of the DC motor to create a magnetic field suitable for attracting down the hook shaft after connecting the direct current. The retraining spring was used to retrain the hook shaft to its start point again after ending its down attract stroke. The picker hook was fixed on the upper end of the hook shaft, its shape like v letter, while the picker shaft guide was used to prevent the picker hook from exiting and rotating in the magnetic coil during picking.

Fig. 1 Main components and schematic diagram of electrical picking hook for peach fruits. Peach electrical picking holder

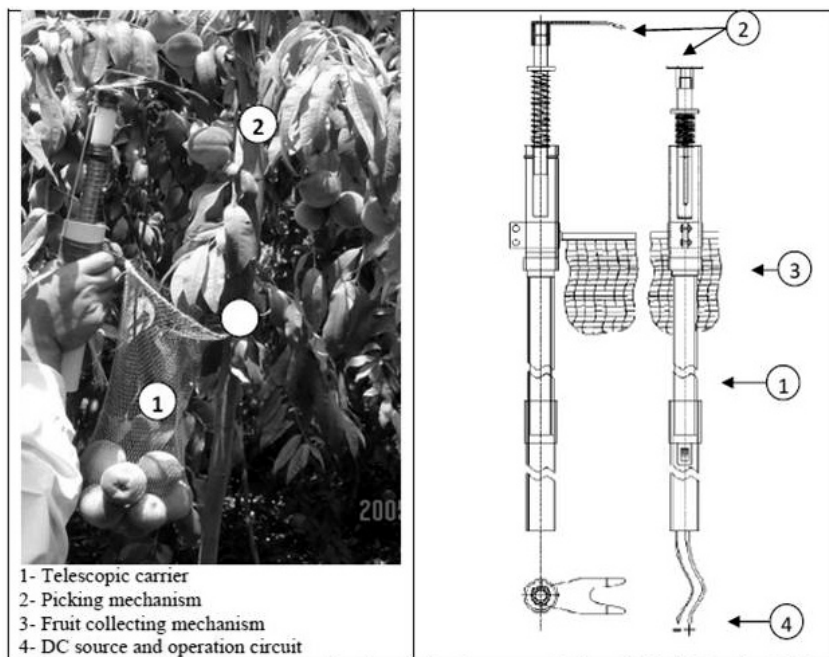

Fruit collecting mechanism consisted of a fruit receiving/transporting tube and fruit collection basket. The upper end of fruit receiving tube ($\phi = 25$ cm) was fixed on the telescopic carrier under the picker hook with about 20 cm to receive and transport the picked fruit to the mobile fruit collection basket.

DC source and operation circuit: a battery (12 V - 70 Ah) was used as the DC source to operate the linear DC motor through electrical cables passed inside the pipes of the telescopic carrier, while the operation switch was fixed on the lower pipe of the telescopic carrier in a suitable place for the operator's hand.

Working theory: the operator (picker) selected the mature peach fruit on the tree and detected it by the picking head by adjusting the two wings of picker hook around the peach fruit twig. A switch was then turned on to connect the DC current to magnetic coil through cables in the magnetic coil to create a magnetic field which pulled the hook shaft to the down side. Consequently, the picker hook detached

the peach fruit and dropped it to the receiving tube. After filling the mobile basket with fruit, the operator emptied it in the fruit boxes.

The main components of the peach electrical picking holder prototype are shown in Fig. 2. These components are described below:

A telescopic carrier consisted of two hollow aluminum pipes 3 m long. The upper one ($\phi = 16$ mm) is inserted into the lower one ($\phi = 25$ mm) to adjust the height of peach electrical picking hook.

The picking mechanism consisted of a linear DC motor, 12 V - 70 Ah, holder shaft, holder cam, retraining spring, picker shaft guide and holder hands. The DC motor was fixed on the upper end of the telescopic carrier, while the holder shaft was fixed inside the magnetic coil of the DC motor to create a magnetic field suitable for pulling down holder the shaft after connecting the direct current to it. The retraining spring was used to reopen the holder hands, again, after the ending stroke to catch another peach. The two holder hands were

fixed on the upper end of the holder shaft. The shape of the holder hand was almost the same as a spoon. The inner surface of the holder hand (spoon) was covered by rubber material. The holder cam was used to make the fruit catching action by the holder hands during attraction of the holder shaft to the down side.

The fruits collecting mechanism consisted of fruit the receiving/transporting tube and fruit collection basket. The upper end of the fruit receiving tube ($\phi = 25$ cm) was fixed on the telescopic carrier under the holder with about 25 cm to receive and transport the picked fruits to the mobile fruit collecting basket.

DC source and operation circuit: a battery (12 V - 70 Ah) was used as DC source to operate the linear DC motor through some electrical cables passed inside the pipes of the telescopic carrier, while the operation switch was fixed on the lower pipe of the telescopic carrier in a suitable place for the operator hand.

Working theory: this mechanism was designed to simulate the same hand picking action of peaches by catching them and attracting them to the down side as it was detach from the twig. The operator selected the matured peach to be picked from fruit distribution layers on the peach trees and positioned the electrical picking holder to it. The operator then switched-on the magnetic coil so that the picker holder catching the peach fruit moved down side rapidly at the same time to detach it from its twig and position it to the fruit collecting basket as shown in Fig. 2.

A traditional peach hand picking hook consisted of a long stick from some plants (about 2.5-3 m long and 3-4 cm diameter) with about 30 cm of steel bar ($\phi = 1.5$ cm) curved and fixed at the upper end of the long stick as shown in Fig. 3. The picker caught this traditional hook and attracted matured peaches by hitting and shaking tree branches. The picked fruit by the hand hook were

Fig. 2 (L) Main components and schematic diagram of electrical picking holder
Fig. 3 (R) Hand picking hook. Traditional Peach hand picking hook

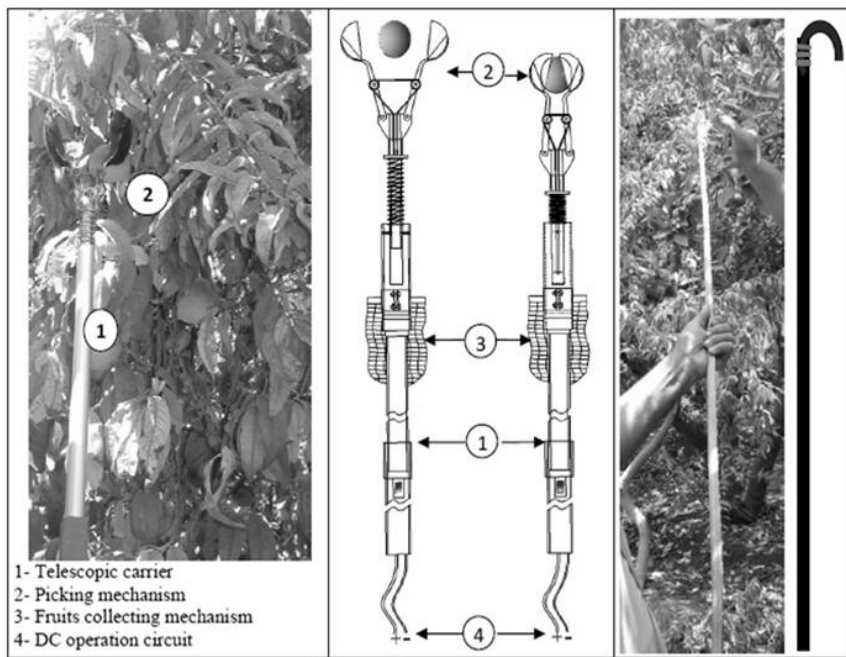

dropped on the ground surface from different fruit distribution height layers. This required another laborer to collect these fruits in fruit the basket.

Performance Test and Evaluation

Two experiments were carried out to evaluate the performance of designed picking peach prototypes during this investigation. The first one was done to study the effect of using the designed electrical picking hook and holder as mechanical methods for picking Early Grand and Meet Ghamr peach varieties and compare with hand hook and hand picking method as a traditional peach picking methods. The second experiment was done to study the effect of using five different pickers (labors) to pick Meet Ghamr peaches from upper and lower parts of fruit distribution layers on the peach trees by mechanical and manual picking methods under study. Therefore, the distribution fruit layers were divided into two parts. The lower part included the first and second fruit distribution layers while the upper part included the third and fourth fruit distribution layers. The evaluation experiments were carried out during peach picking season of 2007 and 2008 at private peach farms in the new reclaimed (rainy) lands, EL-Arish, North Sinai Governorate and old (irrigated) lands, Meet-Ghamr, Dakhalia Governorate, Egypt.

Measurements

Peach Fruit Properties

The physical properties included fruit dimensions: length, diameter, mass and volume. The mechanical properties included fruit penetration resistance and fruit picking force.

Peach Tree Characteristics

The characteristics of peach tree canopy that affect on the performance evaluation of the designed peach picking tools were measured

and the average values were calculated. The measuring characteristics included, tree heights/diameter, number of branches, first branch height, and tree spacing.

Performance Measurements

The performance measurements: total picking time/picker productivity (ton/day) and fruit quality were measured during picking using designed mechanical peach picking tools under study and comparing with other traditional peach picking methods (hand picking and manual hook).

Total Picking Time and Picker Productivity

The total picking time required for selecting/detecting the mature fruit, catching by hook/holder, detaching it and collecting in the fruit basket/box was measured and recorded using five different pickers (labors) with both types of the designed peach picking heads to calculate the average value of picker productivity (ton/day) and comparing with traditional peach picking methods. Also, the total picking time included the lost time in moving picking heads between peach trees and branches, in addition to the time to empty the full fruit basket.

Quality of Harvested Peach Fruits

The quality of picked peach fruit was evaluated by calculating the percentage of the damaged fruit due to dropping it out of the receiving tube/basket and the visible damage percentage in the picked fruits due to cutting it by the picking head parts. The percentage of good fruit quality was determined for the fruit collected in the basket for each picking. Also, the picked peach fruit validity was estimated by storing it for a period of one week under the room temperature using picked fruits by mechanical and manual picking methods.

Results and Discussions

Physical and Mechanical Properties of Peach Fruits

The minimum, maximum, average and standard deviation (SD) values of the physical and mechanical properties of the Early-Grand and Meet Ghamr varieties (El-Arish and Meet-Ghamr regions, respectively) were measured, calculated and summarized in **Table 1**.

The average values of length, diameter, volume and mass of the Early-Grand variety were higher than obtained for the Meet-Ghamr. However, the average values of penetration resistance for Meet Ghamr

Table 1. Physical and mechanical properties for peach fruit

Peach Variety	Measurements	Min.	Max.	Av.	SD.	C.V %
Early Grand	Length, mm	51.00	69.10	62.43	5.09	8.15
	Diameter, mm	55.10	73.50	61.15	5.23	8.56
	Mass, kg	75.00	160.0	107.40	23.32	21.71
	Volume, cm ³	83.5	127.2	96.00	14.6	15.21
	Penetration resistance, N	1.3	17.2	7.89	6.23	78.96
	Picking force, N	11.00	35.03	16.67	9.64	57.82
Meet Ghamr	Length, mm	5.10	6.70	5.84	0.49	8.38
	Diameter, mm	4.85	6.80	5.61	0.54	10.47
	Mass, kg	61.58	158.96	91.88	30.05	32.71
	Volume, cm ³	45.50	185.0	98.00	39.31	40.11
	Penetration resistance, N	4.45	22.25	8.72	5.53	69.51
	Picking force, N	0.10	14.70	4.72	5.96	126.27

Fig. 4 The characteristics of the peach tree canopy

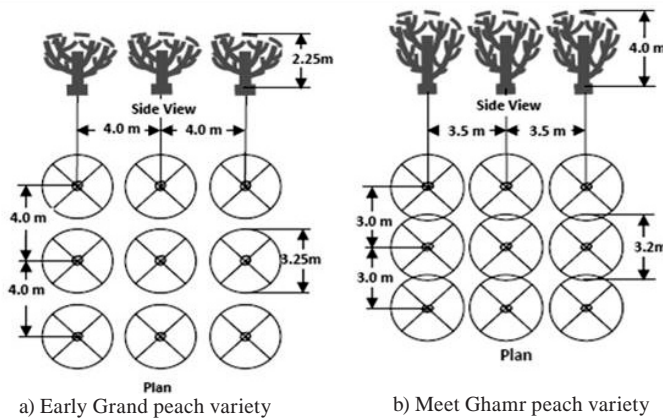

Fig. 5 The fruit distribution percentages on the peach trees

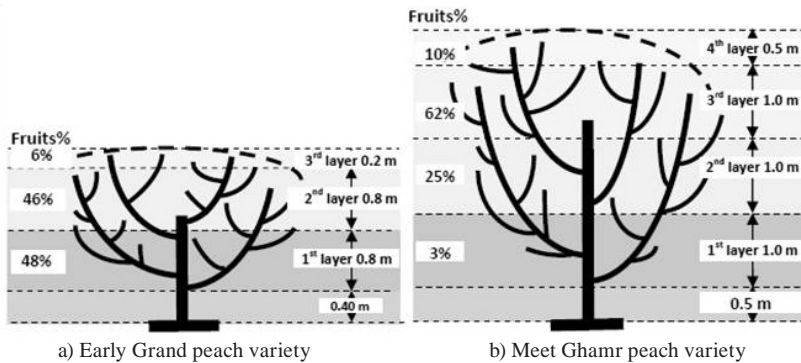

Fig. 6 Effect of using designed mechanical heads compared with traditional methods for picking Meet Ghamr and Early Grand peaches

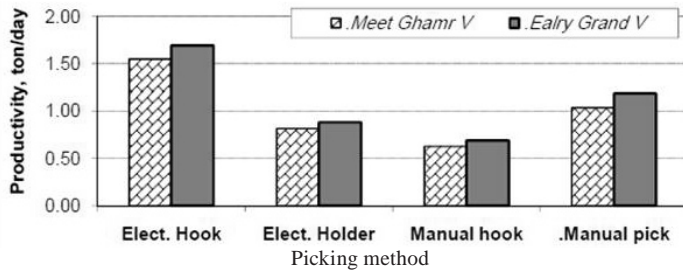
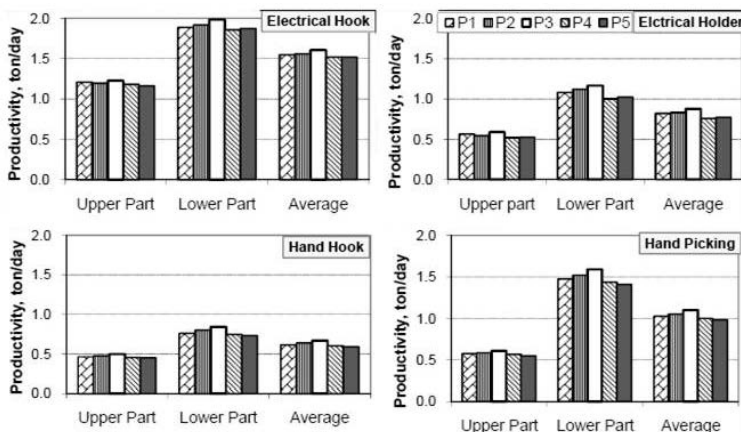

Fig. 7 Effect of using different pickers (P1 to P5) for picking peach fruit from lower and upper parts of the peach tree on the picker productivity



variety (8.72 N) were higher than that (7.89 N) for Early Grand variety. Meanwhile, the average values of the picking force for Early Grand (16.67 N) were extremely higher than that obtained (4.72 N) for Meet Ghamr.

Peach Tree Characteristics

The characteristics of the peach tree canopy and fruit distribution percentage on the tree layers were measured and calculated for Early Grand and Meet Ghamr peach varieties. The results indicated that there were significant differences in the average values of the tree characteristics for both varieties under study as illustrated in **Figs. 4a** and **b**. The average values of tree height, tree diameter and tree spacing were 2.25 m, 3.25 m and 4.0 × 4.0 m, respectively for the Early Grand variety. However, the corresponding values for the Meet Ghamr variety were 4.0, 3.20 and 3.0 × 3.5 m for tree height, diameter and spacing, respectively.

The first main branch starts at an average height of 0.40 m from the ground surface with 4-5 main branches on the Early Grand peach tree. However, the first main branch starts at average height of 0.5 m from ground surface with 4 main branches on the Meet Ghamr peach tree. The fruit distribution of Early Grand variety was concentrated on the outer circumference of the tree on the first and second layers from ground surface. While the upper layer (third layer) contained the lowest percentage of fruit distribution as shown in **Fig. 5a**. The percentage of fruit distribution on the Meet Ghamr trees was concentrated at the outer circumference of the tree on second and third layers from ground surface. The lowest percentage of fruit distribution was on the first layer of the tree as indicated in **Fig. 5b**.

Table 2 Effect of using mechanical and manual harvesting method on peach fruit quality

Picking method	Impacted (dropped) fruit, %	Damaged fruit, %	Good fruits (Extra fancy, %	Av. Validity period
Electrical hook	3.0	1.0	96	5 days
Electrical holder	11.0	3.0	86	3 days
Hand hook	81.0	7.0	12	1 day
Hand picking	4.0	2.0	94	5 days

Performance Evaluation

Picker productivity

The average values of picker productivity (ton/day) was estimated using designed mechanical and traditional picking methods for picking Meet Ghamr and Early Grand varieties. The results are illustrated in **Fig. 6** and indicate that the electrical picking hook gave the highest picker productivity (1.551 and 1.691 ton/day) as compared with other picking methods. However, the hand picking method gave 1.035 and 1.185 ton/day followed by the productivity of the picking holder (0.813 and 0.881 ton/day) and the hand hook (0.625 and 0.688 ton/day) during picking Meet Ghamr and Early Grand varieties, respectively.

The picker productivity using the electrical picking hook was increased by about 90.70, 148.05, and 49.91 % compared with labor productivity using electrical picking holder, hand picking hook and hand picking method, respectively, for picking the Meet Ghamr variety. However, the corresponding values for the Early Grand variety were about 91.94, 145.78 and 47.70 %, respectively. Meanwhile, the picker productivity was more for Early Grand variety by 8.29, 7.70, 9.13 and 12.7 % than the Meet Ghamr variety using electrical picking hook, electrical picking holder, hand picking hook and hand picking, respectively. These results may be due to lower height values of the Early Grand peach tree and canopy volume than the Meet Ghamr trees, which would decrease the lost time during picking operations.

Regarding the effect of using dif-

ferent pickers (P1 to P5) for picking Meet Ghamr fruit from lower and upper parts of peach tree on the picker productivity using mechanical and traditional picking methods: one can say, the picker productivity values varied from one picker to other according to the picker experience and skill as shown in **Fig. 7** using any given mechanical and manual picking method. Also, the picker productivity values increased during picking from the lower part to the upper part for any given picker and picking method. However, the average value of increment percentage between lower and upper tree parts in picker productivity achieved the highest values (61.60 %) with the hand picking method compared with 37.24, 49.19 and 39.43 % with the electrical picking hook, electrical picking holder and hand picking hook, respectively.

Picked Fruit Quality

The effect of using the designed harvesting tool prototypes (electrical picking hook and holder) on the picked fruit quality was measured and estimated in comparison with effect of the traditional picking methods. The percentages of impact (dropped) fruits on the ground surface, the visible mechanical damage percentages in these fruits and the fruit validity by storing one week at room temperature using fruit picked by mechanical and traditional picking methods are summarized in **Table 2**. From these results it could be concluded that using the electrical picking hook gave the lowest percentage of impacted (3.0 %), damaged fruit percentage (1.0 %)

and the highest validity period (5 days) compared with other mechanical and traditional harvesting methods under study. However, using the manual hook gave the highest percentage of impacted (81.0 %), damaged fruit percentage (7.0 %) and the lowest validity period (1 day) due to the impact action for dropped fruits on the ground, especially the matured fruit from third and fourth layers. These results mean that using the designed prototype of electrical picking hook gave the highest value of good quality fruit percentage 96.0 % (extra fancy –grade 1) compared with electrical picking holder, manual picking hook and hand picking method, consequently, increasing the rate of fresh market exporting, in addition to reducing picking cost and increased national income.

Conclusions and Recommendations

The picker productivity using the electrical picking hook increased by about 90.70, 148.05, and 49.91 % compared with labor productivity using the electrical picking holder, manual picking hook and hand picking method, respectively, for picking the Meet Ghamr variety. However, the corresponding values for the Early Grand variety were about 91.94, 145.78 and 47.70 %, respectively.

Using the electrical picking hook gave the lowest percentage of impacted (3.0 %), damaged fruit percentage (1.0 %), the highest validity period (5 days) and the highest value of good quality fruit percentage 96.0 % (extra fancy-grade 1) compared with other mechanical and traditional harvesting methods under study.

The authors recommended to locally fabricate and use the electrical picking hook for picking peach fruits to increase the rate of fresh market exporting, in addition to

reducing picking cost and increasing national income. However, the electrical picking holder still needs some modifications to decrease the percentage of dropped fruits out its fruit basket.

REFERENCES

E.A.S. 2008. Economic Affairs Sector, Ministry of Agric. and Land reclamation, A.R.E.

Erdogan, D., M. Guner, E. Dursun, and I. Gezer. 2003. Mechanical harvesting of apricots. *Biosystems Engineering*, 85(1): 19-28.

Horsfield, B. C., R. B. Fridley, and L. L. Claypool. 1972. Optimum mechanical harvesting procedures for apricots of non-uniform maturity. *Transactions of the ASAE*, 15(5): 878-882.

Horvath, E. and G. Sitkei. 2001. Energy consumption of selected tree shakers under different operational conditions. *Journal of Agricultural Engineering Research*, 80(2): 191-199.

Kader, A. A. 1980. Brown discoloration of clingstone peaches. *Cling peach quart*. 16(1): 12-13.

Kader, A. A. 1983. Influence of the harvesting methods on quality of deciduous tree fruits. *Hortscience*, vol. 18(4): 409-411.

Kunze, O. R., W. H. Aldred, and B. C. Reeder. 1975. Bruising characteristics of peaches related to mechanical harvesting. *Trans. Amer. Soc. Agr. Eng.* 18: 939-941, 945.

Polat, R., I. Gezer, M. Guner, E. Dursum, D. Erdogan, and H. C. Bilim. 2007. Mechanical harvesting of pistachio nuts. *Journal of food engineering* 79: 1131-1135.

Sanders, K. F. 2005. Orange Harvesting Systems Review. *Biosystems Engineering, Power and Machinery*, 90(2): 115-125.

Sansavini, S. and G. Costa. 1986. Mechanical harvesting and pruning of apricot trees. *International Society for Horticultural Science, Second International Workshop*

on Apricot Culture and Decline, Davis, CA, 10-20 August, pp 179-190.

Sansavini, S., G. Costa, M. Grandi, and U. Lunati. 1982. Performance and suitability for mechanical harvesting of processing apricots: a comparison of six cultivars two training systems and prune inter stock. *Symposium on Apricot Culture and Decline*, Bucharest, Romania, 16-21 July, pp 364-374.

Sarig, Y. 1993. Robotics of fruit harvesting: A State of the Art Review. *J. Agric. Eng. Res.* 54: 256-280.

Sims, T., J. Webb, C. Hood, and J. Gambrel. 1973. Quality of fresh market peaches subjected to a mechanical harvesting and field handling grading system. *J. Amer. Soc. Hortscience* 98: 253-256.

Torregrosa, A., B. Martín, J. García Brunton, and J. J. Bernad. 2008. Mechanical Harvesting of Processed Peaches. *Applied Engineering in Agriculture Vol. 24(6): 723-729* (American Society of Agricultural and Biological Engineers).

Zocca, A. and R. B. Fridley. 1977. Mechanical harvesting of clingstone peaches. *J. Agr. Engr. Res.* 22: 247-257

Zocca, A., F. Malaguti, G. Cristoferi, and O. Facini. 1991. Technical data and performance of a fully automated fruit harvester. *International winter meeting of the American society of agricultural engineers* (pp. 1-13); December 17-20, Chicago, IL, USA.



Your Torque Partner



Multiple use capabilities for torque check, data processing and quality control. **STC**



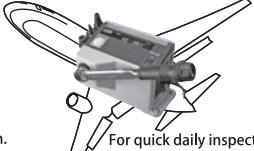

Table top, manual load, digital torque meter ideal for cap testing. **TME**



Wireless "Error Proofing" torque system. **POKAYOKE Torque Wrench FH256MC**



For quick daily inspection of torque wrenches. **LC3-G**

TOHNICHI Japan provides Safety and Reliability with Torque Technology

TOHNICHI 4 SERVICE SYSTEM

<p>Product Services</p> <p>Studies and R&D for Screw-Tightening reliability, Durability and Torque-Measurement</p>	<p>After-Sales Services</p> <p>Testing and Repair, Issuing of Calibration Certificates, Part Supplies, Workshops for Repair and Adjustment</p>
<p>Preliminary Services</p> <p>Open Technical Laboratory, Torque Engineering Seminars, Telephone Consulting, Assistance for ISO Certification</p>	<p>World Wide Services</p> <p>Tohnichi's International Service Network, English Services, Overseas Seminars</p> <p style="text-align: center;">http://tohnichi.jp</p>

Your Torque Partner



TOHNICHI

TOHNICHI MFG. CO., LTD.

Headquarters : Tokyo Japan
E-mail : overseas@tohnichi.co.jp

Problems and Prospects of Agricultural Mechanization in Bihar, India

by



V. B. Shambhu
Senior Scientist (FMP)
National Institute of Research on Jute &
Allied Fibres Technology (NIRJAFT)
12, Regent Park, Kolkata - 700 040
West Bengal, INDIA
vbs9605@yahoo.co.in



S. K. Jha
Scientist,
Central research Institute for Jute &
Allied Fibbers,
Barrackpore - 700 120
Kolkata, West Bengal, INDIA

Abstract

This study was undertaken to identify the constraints in the use of agricultural implements and machinery in the state of Bihar. Farmers of different farm categories were selected. It was observed that mechanization in agriculture is not up to mark because the main problems faced by the farmers in adoption of improved farm equipment were lack of awareness about various farm implements and machinery. The major constraint of farm mechanization in Bihar was size of farm holding. Average size of land holdings across the state was less than one hectare. Land ownership in the state was badly fragmented. Between 85 percent and 90 percent of rural households own less than five acres. The attempts have been made to suggest various recommendations to over-come these problems.

Introduction

Bihar has one of India's most fertile tracts of land. Nearly three-fourths of its population also depends on agriculture for survival. Yet the productivity of the state is below the national average, and

much lower than green revolution states like Punjab and Haryana. Constantly expanding population of Bihar has required and will continue to demand an ever-increasing agricultural production of food and fibre. Mechanization of small farms in Bihar affect all production stages from land preparation to harvesting, and post harvest to processing. As adoption of agricultural machinery increases capital input, it is expected that the level of output should increase. Such changes are likely to have an impact on employment, income and income distribution and social welfare.

There is a considerable controversy about the desirability of agricultural mechanization with modernization so that it becomes the major indicator and requirement for development. A more moderate view holds that the functional relationship between power input and agricultural output is analogous to fertilizer and yield. Therefore, development requires added power in the form of mechanization. A third view holds that the major objective is absorbing the significantly increasing numbers of labourers in the agricultural sector and that mechanization can help through intensifying land use. In this view, mechanization is the

key to increased cropping intensity, which will permit labour absorption at other times during the production cycle.

Agriculture is the mainstay of the people of Bihar. Basic economic features of the state have been compared with the national figures in the **Table 1**.

Table 1 explicitly shows high population pressure on Agriculture with population density at 880 for Bihar against the 324 for India. With fewer industries in the state the share of rural population at 89.5 % is very high. Agriculture contributes 42.0 % of the state GDP against the national figures at only 20.8 %. These statistical figures reveal the importance of Agriculture in the state economy.

Table 1 proves beyond doubt the need to modernize agriculture in the state with the value of output from Agriculture (per hectare) at only 5,939 against the national average at 11,839.

The average land yield in Bihar is just 1,679 kg per hectare, lower than the national average of 1,739 kg and much lower than Punjab's 4,040 kg and Haryana's 3,127 kg per hectare.

Table 1 Basic economic features: Bihar vs. India

Item	Bihar	India
Agriculture as % of GDP (2004-05)	42.0	20.8
Rural population as % of total population (2001)	89.5	72.2
Human population density (per sq.km (2001))	880	324
Per capita Income (at 93-94 prices) in (Rs)	3,574	8,941
Per capita Agricultural Income (at 93-94 prices) in (Rs)	1,508	2,552
Value of output from Agriculture per ha. (at 93-94 prices) in (Rs)	5,939	11,839
Rural Poverty (1999-2000)	40.07 %	27.09 %
Literacy	34.73 %	52.21 %

Source:- DOS, Gov. of Bihar

Methodology

The State of Bihar with an area of 94,163 sq m (93.60 lakh hectares) lies in between latitudes N.24°20' 10" and 27°31'15" and longitudes E 83°19'15" and 88°17'40". The state is bounded on the north by Nepal, on the east by West Bengal, on the west by Uttar Pradesh and on the south by Jharkhand. The state lies between 35 to 85 metres above mean sea level. The total cultivated area is 26.69 lakh ha. The state is divided into three agro-ecological zones. These are, Northwest Alluvial Plains, North-East Alluvial Plains and South Bihar Alluvial Plains. The study was carried out in south Bihar alluvial plain zone. The total geographical area of South Bihar alluvial plain is 41.12 lakh hectares. It receives 1,104 mm average annual rainfall. Net sown area is 21.95 lakh hectares. Total irrigated area is 16.76 lakh hectares. The cropping intensity of the study area is 135.11.

A four stage simple random sampling mechanism was adopted to select a village. This statistical selection procedure comprised districts as the first stage sampling unit, blocks within the selected district as the second stage, village within the selected blocks as the third stage and the farmers within the village as the fourth stage sampling unit.

The farmers were classified into four categories, viz marginal farmers (MF) with less than 2 ha land,

small farmers (SF) with 2 to 4 ha, medium size farmers (MSF) having 4 to 10 ha, and large farmers with more than 10 ha of land holding.

The data collection was done on the basis of a predesigned pretested questionnaire. The information collected includes the various details of the village like farm holding, livestock population, land utilization pattern, irrigation structure, crop rotation, inventory of farm machinery and power sources. The schedule of farm operation activities carried out by the different categories of farmers was monitored to analyse the utilization of different farm power sources in the crop production. The annual availability of commercial power sources like tractor, diesel engine and electric motor was worked out by assuming uniform usage through out the year.

Results and Discussion

Socio-Economic Characteristics of Farmers

Socio- economic profile of farmers revealed that sixty two percent of the farmers were older than 45 years, thirty three percent were between 30 years to 45 years and only five percent were less than 30 years. Among sample farmers, sixty three percent of the farmers were illiterate, twenty eight percent finished primary/middle school, 16 % went to high school and only 3 %

were college or university graduate. Farming was the main occupation for 80 % of the farmers while 8 % were service holders and 12 % were maintaining a small subsidiary occupation like business.

Socio- Economic Factors and Adoption of Mechanization

The progress in agriculture ultimately depends up on the use and adoption of machinery by the farmers.

Equipment

Ploughing on the farms was almost fully mechanized, while other operations were far from mechanized. Planting/sowing, weeding, interculturing, harvesting and post harvesting operations were manually done. Almost all farmers performed tillage operation with locally manufactured desi ploughs/cultivators, applied fertilizers by broadcasting and sprayed chemical using knapsack sprayers. Centrifugal pumps were most common for under ground water pumping.

Most of the farmers were not able to answer questions related to the suitable sizes of their tractor and equipment.

Constraints in Farm Mechanization

In order to know the problems responsible for poor adoption of farm implements and machines, 195 farm families from different farm categories were consulted to obtain their opinion in view of their vast experience in farming.

Farmers were enthusiastic about the use of improved farm implements. In certain pockets they also willingly adopted one or more tillage implements, sowing implement, wheat thresher and plant protection equipment as they felt that these implements increased the efficiency and quality of operation and reduced the drudgery involved in the conventional methods. However, the constraints faced in adoption on a large scale by the farmers are

extension related programmes of agricultural engineering, lack of infrastructure like farm road, electricity, lack of appropriate machines, small land holdings, poor economic conditions, lack of irrigation facility and lack of manufacturer.

The farmers reported the various problems being faced by them in the way of adoption of most of farm implements as summarized below:

Extension programme of agricultural engineering

The Extension Programmes of Agricultural Engineering were found to be very poor in Nalanda district. This was reflected in the awareness of farmers and use of farm implement and machinery. About 96 percent of bullock owned farmers were ignorant about such improved implements as such as M. B. plough, disc harrow, seed drill, olpad thresher, ridger. Similarly about 90 percent of tractor owned farmers were ignorant about improved machinery and implements. About 98 percent of farmers did not know about pedal paddy thresher and power/hand operated maize sheller.

There was no field demonstration or training programme with regard to improved implements. Similarly implement manufacturers were not available except very few low quality thresher fabricators. This was due to poor extension programmes in this direction.

Lack of Appropriate Machine and Equipment

Appropriate types of implements were not available within their easy reach. There were no local manufacturers of agricultural implements in Nalanda district. Only threshers are being fabricated by local artisan.

They felt the need of some vendor or agency (Government or private) which could collect their demands of the implements and arrange to provide at appropriate time and place.

One of the main difficulties with

mechanization in less developed areas was the lack of equipment. Lack of knowledge of existing implements and their performance under field conditions were, also, found to be a bottleneck in mechanization. Lack of market dealers for such implements was also found to be a parameter that retards mechanization.

Small Scale Holdings

The survey revealed that the number of marginal (below 1.0 ha), small (1.0-2.0 ha), semi medium (2.0-4.0 ha), medium (4.0-10 ha) and large (10.0- above) farmers was 241,905, 35,668, 14,835, 2,981 and 44, respectively and possessed 46.25, 24.63, 20.70, 8.09 and 0.33 percent of the total cultivated area in the state respectively.

About 92 percent of land of marginal farmers, 74 percent of land of small farmers, 35 percent of land of medium size farmers and 20 percent of land of large farmers were of tiny size and irregular shape of fields that made it difficult to carry out field operations properly. This was one of the reasons why mechanization remained limited to stationary farm operations and haulage. Farmers felt that this problem could be resolved by introducing joint farming or farming on co-operative basis leading to increase in farm holding size. They were observed to be getting ready for land consolidation by government agencies. Such consolidation could attract co-operative farming or mechanized farming. Land consolidation could be done by the Revenue Department in collaboration with Department of Agricultural Engineers with latest knowledge of farm roads, irrigation systems, irrigation channels, drainage channels and the like.

Scattered Fields

The agricultural set-up remains mired in centuries-old mores. Land reforms have not been implemented effectively. Even the survey of agri-

cultural land has not been completed. Most farmers own sets of separate plots, sometimes numbering as many as 20 making it impossible for them to employ uniform farming techniques on their entire holding.

In Nalanda district, generally fields were small and scattered. About 88 percent farms of marginal farmers, 75 percent of small farmers, 49 percent medium size farmers and 37 percent of large farmers were scattered over the entire area of a village. In some cases, it was beyond the area of the village too. Therefore, farmers were unable to use the machinery gainfully. It took much time and labour to transport them from one field to another. Hence, farmers were unable to adopt intensive cultivation. Small holdings did not lend themselves to mechanization. Particularly if they were scattered (at different locations and of various shapes and sizes.) over large areas, since the cost of transporting machinery to cultivate small plots was far from economical.

Farm mechanization of scattered, parcels of land becomes too difficult and inefficient, which, in turn, reduces agricultural production and owner's incentive for land improvement and achievement of high production. The land consolidation of several fragments belonging to any farmers and the possibilities of gathering together the land fragments registered to different members of a farm family will solve this problem. Chakbandi, or giving compact blocks of land to farmers in exchange for their dispersed holdings.

Lack of Farm Roads

Farm roads are the backbone of farm mechanization. It may not be out of way to discuss about transportability of other parameters of farming like high yielding seeds, fertilizer, insecticides, pesticides, micronutrient and even farming practices. It may be observed that these parameters can travel to farms

on shoulders of farmers or labourers. All these reached Nalanda district and contributed to increase production. But the major parameter called energy input to farms was found to be still missing. The basic source of energy input to farms is still a tractor, which moves on roads and all of its attachments need farm roads to go to the field. This was one of the most important parameters that prohibited farm mechanization in Nalanda district. Farmers reported 100 percent absence of farm roads. There existed no farm road and no approach to a road to the village. Even a cyclist could not go to his village on a cycle. Some farmers had not heard of farm roads or had no concept of farm roads.

Non-Availability of Electricity

Electricity, being a cheaper source of power, is capable of reducing unit cost of operation, which in turn could intensify mechanization. But, due to non-availability of electricity, mechanization was adversely affected. Several farm operations like irrigation, threshing and post production processes could be done at lower cost as compared to diesel power. For an intensive cropping pattern, timely irrigation and quick threshing becomes important. In Nalanda district the water table was low enough to lower the pumping sets to a depth of 4 to 7 m. Under the circumstances, pumping irrigation water by diesel was uneconomical. This was a bottleneck to farm mechanization.

Poor Economic Condition

About 90 percent of marginal farmers, 75 percent of small farmers and 20 percent of medium size farmers were economically poor. Due to this poor economic condition, in spite of their willingness to own farm implements, they were unable to purchase as these did not come in their order of priority of day to day requirements.

More than 80 percent of farmers

use tractors rented from wealthy landlords at exorbitant charges.

Most farmers having small farm holdings could not afford to spare capital out of their own savings to buy farm implements. If farmers had to maintain both tractor drawn and animal drawn implements, it could be very uneconomical. Special machines and implements are required for different crops and also different types of implements are required for specific jobs. This could raise the capital cost of machines beyond reach of the individual farmers. They felt a need for a multipurpose, multicrop implement/machine.

Lack of Irrigation Facility

Irrigation facilities were scarce. While one-third of villages in south Bihar have canals, only one in every eight has a canal in the north. Other sources of irrigation like wells, borings and tube wells, were also few.

Lack of Manufacturers in the State

Most of agricultural machines/implements are imported from other states. This results in high capital investment for a small farm. Even in districts where machines are imported prices of these machines are so high that on small farms where production is low, use of such machines becomes uneconomical.

The high cost of imported machinery has always been a serious limiting factor in mechanization of agriculture. Farmers in this state pay considerably higher for machines than their counterparts in industrialized states like Punjab, Haryana, and U.P.

Lack of Genuine Spare Parts

Farmers faced difficulty in getting genuine spare parts at a reasonable price and at a convenient distance. It badly affected the working of machines. Thus, lack of spare parts for agricultural machinery and equipment was a major problem which greatly affects all mechanization

schemes in the district.

Poor after Sales Service

Service facilities provided by the dealers were found meager. Sometimes no after-sales service was available. Thus lack of well equipped workshops in the districts made it difficult to carry out mechanization programmes successfully.

Since, after-sales service facilities were not available locally, they had to travel long distances for petty jobs. Sometimes, they also faced problems of getting their implements repaired within the optimum time for the farm operation.

Lack of Training Centre

The vocational education of most of the farmers in the state was very poor. Almost all the farmers surveyed were illiterate and had little experience with agricultural implements. The farmers have little or no exposure to modern machines for farm operation and were hesitant to even try handling a power operated equipment. A programme of farmers training in handling and managing farm machinery was felt a bare need to make mechanization a success. Farmers were looking for a training center where they could get training in tractor driving, hitching of implements, ploughing, harrowing, seed sowing, cultivating, spraying, dusting, harvesting and their repair and maintenance. They also need a knowledge/training programme for repair and maintenance of diesel engines and electrical motors. Due to lack of proper training they were unable to utilize the machine properly.

They felt immediate need of establishment of such training centers either by a government organization, agricultural universities, KVVKs or NGOs that could take up the job on lines of tractor training centers Budhni and Hissar.

Credit Availability

The farmers of the district ex-

pressed great difficulty in availing credit facilities for the purchase of implements. They reported that formalities and number of visits required for availing credit were too many. They also feared as to how many times they would be required to repay the credit obtained on account of suspected foul play in societies. They wanted interest free credit for purchase of implements and machinery.

Awareness Toward Banking Facilities

About 44 percent of the farmers in the state were illiterate and unaware of such facilities. Some of them who were willing to take advantage of modern technology were too poor and could not mortgage their property to secure a bank loan. Only a few farmers owned a tractor and few could afford to hire. Also, banking facilities were not available in rural areas. Even where it was available, farmers were not educated to take advantage of the banking facilities. They were not habituated to deposit their money in a bank or to take a loan from a bank and refund it. It was required to educate them, to expose them, to banking and make them habitual of bank use.

Institutional Aspects of Farm Mechanization

Enlarging the operations of small-scale farmers can be carried out in two ways: expanding the size of land holdings, and expanding the scale of farm management. Since forest clearance is now coming to an end, expanding farm size can be done only through land reform, land resettlement and land consolidation programmes. To expand the scale of farm management requires both government programmes and the farmers' own farming skills in order to introduce improvements such as multiple cropping and integrated crop-livestock farming. Agricultural infrastructure must be improved as a prerequisite for bet-

ter farm management. For instance, an improved irrigation network is necessary for a multiple cropping system. At present only 20 % of the rice planting area, mostly in the central plains, is irrigated while the remaining 80 % is rainfed and can only produce one crop a year. Agricultural credit also needs to be prompted. Farm road improvements require a high investment cost, but it may promise good returns.

Conclusion

On the basis of the survey it was found that the number of tractors was about 17 per thousand hectare of cultivated land which was more than double the state average. But, use of implements was limited to cultivator and trailer. Similarly the uses of animal drawn and manually operated tools were very few. However, a thresher and water lifting pumps were 203 and 376 per thousand hectare basis.

The main constraint in farm mechanization was lack of an extension programme, farm road, availability of implements and consolidation of land holdings. If this were improved through joint efforts it could be a boom for larger extent of adoption of farm machinery and implements and, simultaneously, help in increasing the farm mechanization process.

REFERENCES

- Das, S. K. and S. C. Pradhan. 1988. Agricultural mechanization in Orissa, India. *Agricultural mechanization in Asia, Africa and Latin America (AMA)*. 19(1): 69-72.
- Kumar, A. and A. Sharma. 1991. Agricultural mechanization in Rajasthan. *Agricultural mechanization in Asia, Africa and Latin America (AMA)*. 22(1): 69-72.
- Mittal, V. K., B. S. Bhatia, and A. M. Chauhan. 1989. Food security

through farm mechanization. *The Punjab science. Farm Power and Machinery, ASAE*, Jan. 5-7: 88-95.

- Patel, A. R. 1981. Farm mechanization in India. *Agricultural Engineering Today*. December 12.
- Ray, A. K. 1993. The present status of Agricultural mechanization and its constraints. *Agricultural situation in India*. 148 (4): 245-250.
- Shambhu, V. B. and R. B. Ram. 2007. Status of farm mechanization in Nalanda of Bihar. *Agricultural Mechanization in Asia, Africa and Latin America* 38(1): 18-22.

■ ■

Effect of Blade Angle and Speed of Onion Harvester on Mechanical Damage of Onion Bulbs

by
Jafar Massah

Ahmad Lotfi

Akbar Arabhosseini

Department of Agrotechnology,
College of Abouraihan, University of Tehran, Tehran, IRAN
jmassah@ut.ac.ir.

Abstract

A blade is usually mounted on the head of the onion harvester at certain angle to take the bulbs out of the soil. The blade angle and harvesting depth have significant effects on the efficiency of the harvester and also on the percentage of the damaged onion bulbs. In this study, a head for onion harvester was designed and developed and then the performance of the machine was investigated in a farm with clay-loam soil which the plants were planted in rows. A four bar mechanism was used for changing of the blade angle. The experiments were performed at vehicle speeds of 1.8, 2.4 and 3 km/h and the blade angles of 12, 15 and 20 degree. A factorial experiment was conducted based on a randomized complete design. The best performance of the harvester was found at vehicle speed of 1.8 km/h and the blade angle of 20 degree. The percentage of the damaged bulbs caused by the harvester was less than the manual method.

Introduction

Onion is one of the vegetables which majority of the people con-

sume every day. The large scale onion farms need new mechanized machines to have more productions per certain area. Some farmers still use the traditional method with considerable labor costs in order to minimize the damage of the bulbs during harvesting. In the most of onion harvesters, the undercut system take the onions out of the soil, release them on the ground and allows the bulbs to lay on the surface for curing. Undercutting operation may involve using a straight blade or a rotation bar (Maw and Smittle, 1986). During curing, the onion bulbs cease to use nutrients from the soil and proceed to enhance flavor by mobilizing nutrients from the tops into the bulb. Curing also dries the skin, sealing the bulb and reducing the likelihood of disease organism's entering the bulb. The onions require careful handling in order to minimize damages and to enable an extended shelf life (Maw *et al.*, 1996). Mechanization of onion harvesting has taken place over many years (Chesson *et al.*, 1978). Damage can occur when the bulbs collide with a mobile or fixed part of the machine, by stones, soil, or the other bulbs (Altintas and Bal, 2008). During storage, the onions expose to different forms of storage loss, e.g. water loss due to transpiration,

respiration, microbial infection, physiological disorders and activation of growth, leading to formation roots and sprouting (Suojala, 2001). These diseases may occurred by damaging during harvesting.

The onion harvesting systems involves several operations including topping, undercutting, trimming, field curing and sometimes windrowing. Lorenzen developed a single machine that was able to grasp and support onion bulbs by their tops as they were undercut and lifted from the ground (Lorenzen, 1950). In Idaho, an infield topper was developed that would top onions before they were undercut even after the tops were lodged or had fallen over (Carson and Williams, 1969). A rotary knife was used to cut the tops for each row. Fallen tops were picked up by tined or spider wheels. Nevertheless, Carson and Williams recognized that variations in onion height, top moisture content, onion quality, and soil conditions affected the performance of the topper. In a research in?field topping techniques evaluated and the rotary knife was chosen over either a flail or sickle bar type, yet weeds were acknowledged to choke the mechanism (Droll *et al.*, 1976). The topper was mounted under a tractor in advance of an under-cutter that

left onions for field curing on top of the bed. Further trimming was suggested either on the harvester or at the packing shed.

Williams and Franklin addressed the lifting of onions from a bed after they have been undercut and left in the field to cure (Williams and Franklin, 1971). A potato loader was used for loading of onions into bulk trucks or pallet bins on a trailer. Experiments showed that keeping an elevator full of onions reduce the likelihood of damage of those onions from rolling down the elevator. A mechanical harvesting system was developed for soft sweet onions of the cultivar (LePori and Hobgood, 1970). There was an expressed need for gentle bulb handling and accommodation of green tops. Examination was done about oscillating and rotary bar under-cutters as part of a harvesting system for sweet onions (Maw and Smittle, 1986). Analyses on onion cleanliness, damage, and disturbance revealed that operating the rotary bar with a rotational speed of 540 rpm, a depth of 25 mm below the soil surface, and a forward speed of 6.4 km/h ensured the most favorable results. As a step towards full harvesting mechanization for sweet onions grown in Georgia which is normally harvested by hand, an onceover har-

vester was developed (Maw *et al.*, 1998). Considering the availability of existing onion harvesting systems, a research was done to examine the suitability of such harvesting system for sweet onions which the system consisted of undercutting and field curing. At all stages of the system performance the onion damage was kept to a minimum level.

This paper considers the effects of blade angle and speed of onion harvester on mechanical damage of onion bulbs.

Materials and Methods

A head was constructed for the onion harvester in order to study the effect of vehicle speed as well as the blade angle, α , **Fig. 1** of the harvester on mechanical damages of the onion bulbs. As shown in **Fig. 2**, the machine consists of chassis, under-cutter blade and a mechanism to change the harvesting depth.

The chassis was made in a rectangular shape with dimensions of 150 cm in length, 60 cm in width and 66 cm in height. As the machine is a semi mounted type, two in line idler wheels were assembled at the rear part of the machine. The under-cut system consists of a flat blade with 20 cm in length, 30 cm in width and apex angle of 100 degrees. The

blade cuts the soil and roots of the onion bulbs at a desired depth, and brings them up and release on the topsoil. Root pruning could be accomplished by passing the blade just below the base of the onion bulbs while they are not in the same depth level in the soil. When the blade passes through the soil below the onion bulbs the under-cut system lifts and rolls them over the fingers. The fingers with 10 cm in length were attached at the end of the blade with 3.5 cm distance between them to separate the soil from the onion bulbs. The depth and angle of the blade were set by a four bar mechanism (**Fig. 3**).

The main purpose of using the mechanism was to change the harvesting depth. The mechanism consists of a power screw (DIN 103, Tr 28 × 5), copulative arms, slider and blade. The copulative arms adjoined to the blade with notched part which the size of the notch was 2 cm. The linkage bar moves on the rail by rotation of power screw and causes change of the angle and depth of blade. The depth of the blade was related to the angle of blade which is shown in **Table 1** for some steps.

All experiments were done in a field in Pakdasht near Tehran-Iran. The soil of the field was sandy-loam with 13 % moisture content

Fig. 1 The blade angle, α .

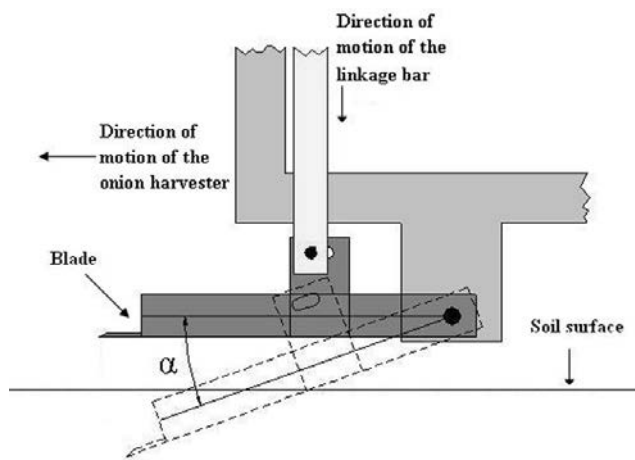
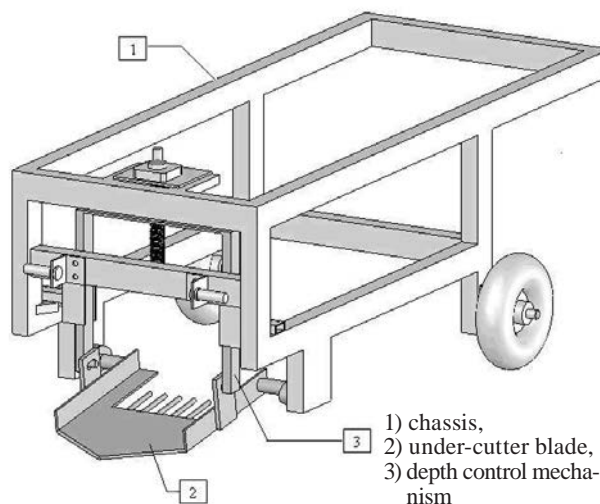

Fig. 2 The onion harvesting mechanism:



- 1) chassis,
- 2) under-cutter blade,
- 3) depth control mechanism

Table 1 The working depth of the onion harvester at three blade angles

Blade Angle (degree)	12	15	20
Working Depth (mm)	24	44.45	78.73

during the experiments. The variety of onion was White Qom and the harvesting head was pulled by a Goldoni tractor. The harvester was then operated at three vehicle speeds of 1.8, 2.4 and 3 km/h and three blade angles of 12, 15 and 20 degree in a randomized complete design with three replications. Each replication was a row with a length of 10 m. The effects of vehicle speed and blade angle on the quality performance of the machine was studied regarding to damages (light and heavy damages) and percentage of the harvested onions.

Results and Discussion

The variance analysis for the harvesting onion percentage in field is

Table 2 Result of variance analysis of harvesting onion percentage

Source	d.f.	SS	MS	F
Blade Angle	2	26.96	13.48	10.11**
Vehicle Speed	2	0.29	0.14	0.11 ^{ns}
Blade Angle × Vehicle Speed	4	1.48	0.37	0.28 ^{ns}
Total	8	28.73		

d.f: Degree of freedom; SS: Sum square; MS: Mean square; F: Statistical distribution
**significant at level 1 %

shown in **Table 2**. The statistical results of ANOVA indicated that the influence of blade angle on the percentage of the harvested onions was significant. While the effect of vehicle speed and the interaction effects of the independent variables were not significant.

The percentage of the harvested onions at different blade angles is shown in **Fig. 4**. The percentage of the harvested onions increased by increasing of the blade angle but changes of blade angle from 15 to 20 degree had no effect on percentage of the harvested onion.

The mechanically damaged onions were divided into two categories: a) Lightly damaged onions that scraped the external skin and

the likelihood of disease organisms entering the bulb are low and, b) Heavily damaged onions that in this case the internal layers of bulb injured which causes a reduction in quantity and quality of the onions and an increases in the incidence of losses and diseases during storage.

The variance analysis results for percentage of lightly damaged onions are shown in **Table 3**. The lightly damage was influenced by the blade angle during harvesting operation. The vehicle speed and the interaction effects of the independent variables were not significant on this factor.

The percentage of lightly damaged onions is shown in **Fig. 5**.

For lightly damaged onions, the

Fig. 4 The mechanism for changing of harvesting depth.

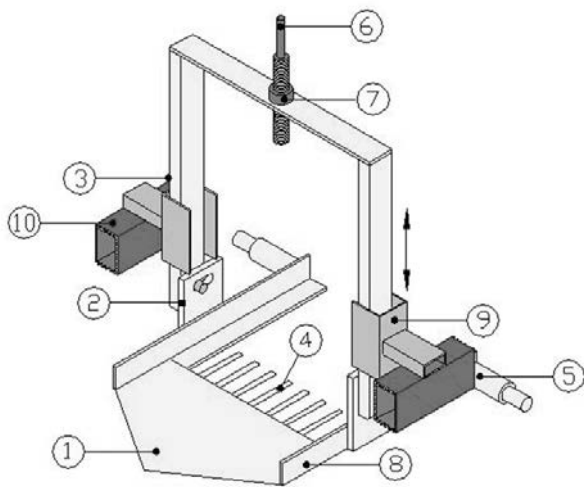

- 1) blade, 2) notched part, 3) linkage bar,
- 4) separating finger, 5) chassis, 6) power screw,
- 7) power nut, 8) U shape part.

Fig. 5 The percentage of onions which are lightly damaged

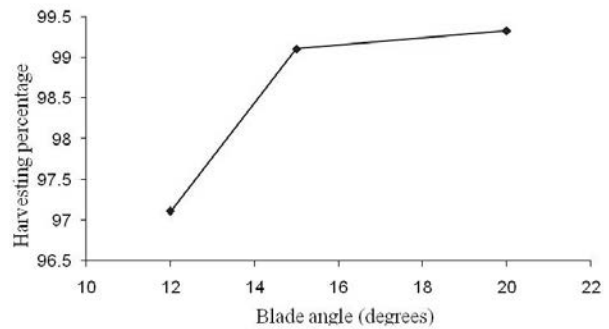

Fig. 6 The percentage of onions which are heavily damaged.

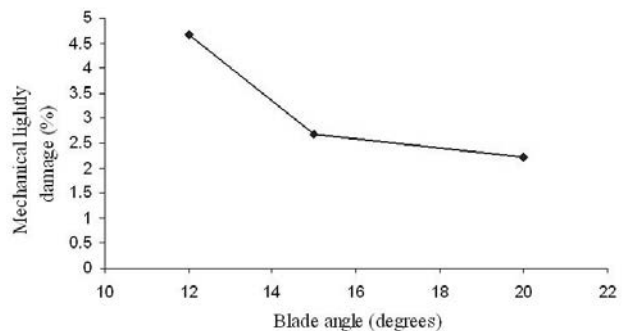

Table 3 Analysis of variance of percentage of the harvested onions which are lightly damaged

Source	d.f.	SS	MS	F
Blade Angle	2	30.51	15.25	12.88**
Vehicle Speed	2	3.85	1.92	1.63 ^{ns}
Blade Angle × Vehicle Speed	4	2.37	0.59	0.50 ^{ns}
Total				

d.f: Degree of freedom; SS: Sum square; MS: Mean square; F: Statistical distribution
^{*}significant at level 1 %

Table 4 Analysis of variance of percentage of the harvested onions which are heavily damaged

Source	d.f.	SS	MS	F
Blade Angle	2	292.74	146.37	89.82**
Vehicle Speed	2	14.51	7.25	4.45*
Blade Angle × Vehicle Speed	4	13.92	3.48	2.14 ^{ns}
Total	8	323.17		

d.f: Degree of freedom; SS: Sum square; MS: Mean square; F: Statistical distribution
^{*}significant at level 1 %, ^{**}significant at level at 5 %

least damage occurred at the blade angle of 20 degree. In 20 degree angle the depth of blade is further than other angles. It causes to compose the bed of the soil under bulb to avoid damages.

The variance analysis results for percentage of heavily damaged onions are shown in **Table 4**.

The statistical results on heavily damaged onions indicated a significant effect for the vehicle speeds at 1% and angle of blade at 5 %. The interaction effects of the independent variables were not significant (**Table 4**).

The percentage of heavily damaged onions is shown in **Fig. 6**.

For heavily damaged onions, minimum damage occurred at combinations of 2.4 and 1.8 km/h vehicle speeds and blade angle of 20 degree. The interaction effects of the independent variables were not significant. Even though the vehicle speed of 2.4 km/h could be a relevant speed for harvesting. But it is unlikely achievable for all field conditions. The 20 degree of blade angle showed a good response at all vehicle speeds. Although the results indicated that the blade angle beneficially could be increased above 20 degree but the vehicle speed must be slower than 2.4 km/h.

An amount of 45 kgf sample out of 378 kgf manual-harvested onion bulbs was inspected to compare the damages between the manual and machine harvesting methods. The sample of manual method was taken from the bags of onions of the same field where the machine harvester was used. Approximately 30 % of the onion bulbs were found to have either light or heavy damages. This level of damage was more than the onions harvested by the machine.

Conclusion

The effects of blade angle and vehicle speed were investigated regarding to the performance of an onion harvester machine. The vehicle speed of 2.4 km/h and blade angle of 20 degree were chosen for harvesting operation based upon the damages of the harvested onions. The harvester provided less damaged onions than those harvested manually.

REFERENCES

Altintas, S., and Bal. U. 2008. Effects of the commercial product based on richoderma harzianum

on plant, bulb and yield characteristics of onion. *Scientia Horticulturae* 116: 219-222.

Anonymous. 2004. azarbayejan farm Report.

Carson, W. M., and L. G. Williams. 1969. Design and field testing of an experimental onion topper. *Transactions of the ASAE* 12(2): 228-230.

Chesson, J. H., H. Johnson, C. R. Brooks, R. G. Curley, P. F. Burkner, and R. M. Perkins. 1978. Mechanical harvesting investigations for fresh market onions. *Transactions of the ASAE* 21(5): 838-842.

Coble, C. G., W. H. Aldred, and R. C. Dillon. 1976. Mechanized harvesting system for fresh market onions. ASAE Paper No. 761532. St. Joseph, Mich.: ASAE.

Droll, E. W., R. E. Armstrong, C. G. Coble, and W. H. Aldred. 1976. Mechanical onion top removal and related preharvest practices. *Transactions of the ASAE* 19(6): 1048-1050.

LePori, W., and P. Hobgood. 1970. Mechanical harvester for fresh market onions. *Transactions of the ASAE* 13(4): 517-519.

Lorenzen, C. 1950. The development of a mechanical onion harvester. *Agricultural Engineering* 31(1): 13-15.

Maw, B. W. and D. A. Smittle. 1986. Undercutting onions. *HortScience* 21(3): 432-434.

Maw, B. W., D. A. Smittle, B. G. Mullinix, and J. S. Cundiff. 1998. Mechanical harvesting of sweet onions. *Transactions of the ASAE* 41(3): 517-524.

Suojala, T. Effect of harvest time on storage loss and sprouting in onion. *Agricultural and food science in Finland*. Vol(10): 323- 333.

Williams, L. G., and D. F. Franklin. 1971. Bulk harvesting, handling and storage of yellow sweet Spanish onions. *Transactions of the ASAE* 14(1): 55-59.

■ ■

Anthropometric Analysis of Selected Body Dimensions of Farm Workers for Design of Agricultural Implements – An Approach

by
M. P. Chandra

S. C. Sharma

Ex-PG Scholar, Allahabad Agricultural Institute Deemed University,
Allahabad (Uttar Pradesh) and Scientist,
Indian Institute of Natural Resources (Jharkhand) INDIA

Abstract

The anthropometric analysis was carried out to determine suitability of major body dimensions of farm workers (male/female) for design of farm implements and machines. Major body dimensions were analyzed to compute parameters namely range, average, 5th, 50th and 95th percentile, standard deviation, and covariance of each major body measurements. Analysis of major body dimension revealed that all the body dimensions were similar to the values reported by Indian researchers except the chest circumference which was slightly higher than the farm workers of western and southern part of the country.

Introduction

Ergonomics is the study of designing objects to be better adapted to the shape of the human body or to correct the user's posture. In recent years, ergonomists have attempted to define postures that minimize unnecessary static work and reduce the forces acting on the body. All of us could significantly reduce our risk

of injury if we could adhere to the ergonomic principles. Ergonomics makes use of information from the disciplines of anatomy, demographics and physiology to measure the physical characteristics of people and their responses to their environments, with particular reference to health and performance. In order to specify systems structures, suitable to achieve a good quality of working environment and better performance, social and organizational aspects of individuals and groups are recognized as the social dimension of ergonomics. Ergonomic engineering controls are physical changes to a job that reduce musculoskeletal disorders. Since musculoskeletal disorders in the United States are estimated to be 130 million total health care encounters, including outpatient, a hospital and emergency room visit. Ergonomics is the new guardian of the modern day workplace.

Most of the farm operations should be performed within a stipulated period of time if optimum results or maximum crop returns are to be obtained. This must be coupled with the improvement of working conditions and performance

of jobs with ease. The design of a machine was of paramount importance rather than its user and hence little consideration was given to his efficiency, comfort and safety in using equipment. With the advent of technology, such disregards for the human factors were no longer possible and, thus, came into existence a relatively new area of human factors engineering that takes care of the human capacities, body dimensions, equipment and related workspaces.

Anthropometry is defined as the art of measuring human body dimension to a considerable accuracy. Both the designer and the ergonomist have a continuing need to update anthropometric data to design and develop equipment working situations and clothing for optimal use, with higher degree of accuracy. The number of anthropometric surveys carried out in the country are very small and the dimensions included are very specific to the requirement. Since there is a considerable difference between the anthropometric data of Indian and the 'Western Population'; therefore, it is necessary to have data on Indian farm workers to assist in proper farm equipment design.

Lehman (1958) studied the relative positioning of brake and clutch pedals, foot rest, steering column and steering wheel. He concluded the optimal direction for applied pedal thrust must be 70 degrees with vertical and height of seat 200 mm (for clutch and brake pedals). He also reported that most satisfactory seats had a parallel seat suspension and hydraulic damping for tractor vibration. Kaul and Splinter (1964) observed that tool, implement and equipment are not worth owning or adopting if these do not reduce the drudgery of workers. According to them, relief from drudgery is as excellent way that quantifies the performance of an improved tool/implement/equipment. Varma (1970) studied the vibrational characteristics of different tractor seats namely seat having solid rubber, single and double leaf spring and helical spring with hydraulic shock absorber. He reported that a seat having a helical spring (spring rate 10 kg/cm and damping constant 0.6 to 0.8 kg.sec/cm) gave better desirable ride comfort and a single leaf seat gave poorest performance among all the tested seats. Sen *et al.* (1977) conducted a survey of 192 male workers (agricultural and industrial) of Eastern India. They found that the body weight, chest, circumference, hip breadth were around 5 to 10 percent higher in case of industrial workers. They compared their study with those of American and European subjects and observed that the Indian values were much lower than those of western workers. Gupta *et al.* (1983) conducted a survey of farm workers of Punjab in connection with the design of seats for machines such as combine harvesters. They reported that workers from Punjab were taller and heavier than those from other parts of the country. They also pointed out that there was considerable difference between workers. Gite (1992) studied on optimum handle height of an animal drawn mould board plow

and blade harrow based on Indian anthropometric data. He emphasized that with optimum handle height the performance was higher and more comfortable to the operator. Gite (1993) has reviewed the work done in India during last three decades in the field of ergonomics applied to farm machinery and power. Available information suggested that the quantum of work done was rather small. However, area covered was broad. According to him, the awareness of the need of application of ergonomics is increasing.

With the growth of farm mechanization in Indian Agriculture, more and more hand tools, implements and machines are being used for performing various agricultural operations. All these machines are operated/controlled by a human. Human comfort is necessary to design the agricultural equipment. A well-planned anthropometric survey depends to a large extent on the detailed racial history and environmental conditions of that place. Anthropometric dimensions of various ethnic groups in a vast country like India will require a great effort, sincerity and time. However, it is extremely important to create a data bank for a greater human-machine interface like workspace near industrial machines, safety devices, design of levers and controls in vehicles and operator environment. While it is imperative that such a task will require a huge effort, one needs to approach the problem from pinpointed objectives in a quick result oriented manner. In the present investigation, relevant anthropometric dimensions were recorded for agricultural workers of Etawah district of Uttar Pradesh.

Materials and Methods

In the present investigation, anthropometric data of farm workers (male and female) were collected from eight villages of the Etawah

district of Uttar Pradesh. From each village, 15-20 farm workers were selected including 80 % male and 20 % female on the basis of their contribution in agricultural operations for the region.

Integrated Composite Anthropometer

The Integrated Composite Anthropometer was used to collect anthropometric dimensions of the farm workers for the present investigation. The most relevant dimensions for design of agricultural machines were taken into consideration.

Measurement Technique

The measurements of the subjects were taken in a minimum clothed condition to attain the maximum accuracy. All the lateral dimensions were taken from the left side of the subject and transverse dimensions from the ground. Most of the static anthropometric dimensions were conventional body length or diameters. These were retained not only because they afforded standards of comparison but because the dimensions like stature, weight, hand length, foot length are the principal dimensions on the basis of which other dimensions can be figured.

Computation of Different Parameters

The anthropometric data such as weight, stature, chest circumference, bideltoid breadth, arm reach from wall, sitting height, popliteal sitting height, buttock popliteal length, span, hip breadth sitting, functional leg length, palm length, foot length, manton to top of head and eye height were determined for farm workers (male and female) using standard methods and instruments.

Results

Anthropometric data of 15 major body dimensions (**Table 1**) of 102

Table 1 Anthropometric Analysis of Male and Female Farm Workers of Etawah District (Uttar Pradesh)

Dimensions	Reading in cm (unless otherwise mentioned)													
	Range		5th percentile		50th percentile		95th percentile		S. D.		Covariance		Average	
	Male	Female	Male	Female	Male	Female	Male	Female	Male	Female	Male	Female	Male	Female
Weight	46-85	28-60	50	30	58	40	79.4	52.3	9.6	7.8	15.07	19.6	61.3	39.7
Stature	157-176	132-165	155	141.1	165	150	175.3	157.8	6.8	6.6	4.1	4.42	165.5	149.2
Chest circumference	79-106	64-102	84.8	68	93	79.5	105	97	7.3	9.2	7.7	11.5	89.3	79.8
Bideltoid breadth	40-51	38-50	40.7	36.3	44	46.2	50	53.7	3.5	5.3	7.7	11.7	45.0	45.1
Arm reach from wall	78-95	67-92	81	70	84.5	78.5	93	83.8	4.3	5.3	4.9	6.8	86.4	77.9
Sitting height	58-89	66-81.5	59	70	83	75	88.3	80.9	8.8	3.8	10.9	5.2	80	74.8
Popliteal height sitting	40-59	35-46	40	36	46	40	55	44.8	4.4	2.7	9.5	6.6	46.2	40.3
Buttock poplital length	44-48	40-55	43.2	42	46.2	48	49.5	51.7	1.9	3.8	4.2	7.9	45.3	40.5
Span	152-195	130-165	155.7	142	175	155	190	164.3	11.4	7.6	6.5	5.1	176.7	153.8
Hip breadth sitting	23-45	21-44	25	22	33	29	42	39.8	5.6	5.7	16.3	19.4	34.3	29.4
Functional leg length	87-118	82-103	90	83	100	94.5	117	99.8	10.6	5.4	10.2	6.8	103	93.4
Palm length	7-11	8-11	8	8	10	9	11	4.8	1.0	0.8	11.0	0.9	9.5	9.3
Foot length	18-25	20-25	19	20.6	22	22.5	25	24.4	3.1	1.4	12.9	6.2	24.2	22.4
Menton to top of the head	16-24	16.5-20.5	17	17.5	20	19	23.5	20	2.1	0.9	10.1	4.6	20.3	18.8
Eye height	143-170	121-159.5	143.7	128.1	152.05	140	169	145.8	9.2	7.3	5.9	5.3	155.7	138.9

male and 26 female farm workers were collected for the present investigation for Etawah district of Uttar Pradesh. The detailed observations obtained are discussed.

Weight and Stature

The weight of farm workers ranged from 46 to 85 kg and 28 to 60 kg, respectively, for male and female. The 5th, 50th and 95th percentile values for men farm workers were 50, 58 and 79.4 kg and 30, 40 and 52.3 kg for female farm workers. The average weight of men was 61.3 kg and 39.7 kg for female farm workers. The average weight criteria of women showed a lower average value as compared to men. The covariance and standard variation for male and female farm workers were 15.07 kg and 19.6 kg and 9.6 and 7.8, respectively. The average value of weight of male and female farm workers resemble the Indian situation as observed by various researchers.

The stature is an important dimension for determining several other human dimensions. The stature dimen-

sion ranged from 157 to 176 cm for male farm workers and 132 to 165 cm for female farm workers. The stature dimension was fairly homogenous for female farm workers. The 5th, 50th and 95th percentile values for stature were 155, 165 and 175.3 cm for male and 141.1, 150 and 157.8 cm for female farm workers. The covariance for farm workers was 4.1 cm and 4.42 cm, respectively, for male and female. The average and standard value of stature for male and female farm workers were very close to the values observed by Indian researchers.

Chest Circumference and Bideltoid Breadth

The chest circumference for male farm workers was 79 to 106 cm while it was 64 to 102 cm for female. The 5th, 50th and 95th percentiles for chest circumference for male workers were 84.8, 93.0 and 105 and 68, 79.5 and 97 for female farm workers with covariance of 7.7 and 11.5 cm and standard deviation of 7.3 and 9.2, respectively, for male and female. The difference in average chest circumference was 9.5 cm, which must to be taken in to consideration when designing a machine suitable for both (male and female).

The bideltoid breadth distribution for male farm worker ranged from 40 to 51 cm and from 38 to 50 for female. The 5th, 50th and 95th percentiles for bideltoid breadth were 40.7, 44 and 50 cm and 36.3, 46.2 and 53.7 cm with covariance of 7.7 and 11.7 cm, respectively, for male and female farm workers. The standard deviation for male was 3.5 cm and 5.3 cm for female farm workers. The average bideltoid breadth value was 45 cm and 45.1 cm, respectively, for male and female farm workers.

Arm Reach and Sitting Height

The arm reach was determined with respect to a wall and was an important dimension that ranged from 78 to 95 cm for male and 67 to

92 cm for female farm workers with an average of 86.4 and 77.9 cm for male and female. The 5th, 50th and 95th percentile for arm reach were 81, 84.5 and 93 cm and 70, 78.5 and 83.8 with covariance of 4.9 and 6.8, respectively, for male and female farm workers. The standard deviation for arm reach was 4.3 and 5.3 for male and female farm workers, respectively.

Range of sitting height was 58 to 89 cm and 66 to 81.5 cm for male and female farm workers with 5.2 cm difference. The 5th, 50th and 95th percentile were determined to be 59, 83 and 88.3 for male and 70, 75 and 80.9 for female farm workers. The covariance in sitting height for male and female was determined as 10.9 cm and 5.2 cm, respectively, with average sitting height as 80 cm for male and 74.8 cm for female farm workers along with standard deviation of 8.8 cm and 3.8 cm, respectively.

Popliteal Height Sitting and Buttock Popliteal Length

The popliteal height and buttock popliteal length ranged from 40 to 59 cm and 44 to 48 cm for male and 35 to 46 cm and 40 to 55 for female farm workers, respectively. The 5th, 50th and 95th percentile for popliteal height and buttock popliteal length were 40, 46 and 55 and 43.2, 46.2 and 49.5 cm for male; and 36, 40 and 44.8 and 42, 48 and 51.8 for female farm workers, respectively. Covariance for popliteal height and buttock popliteal length of male were 9.5 and 4.2 and 6.6 and 7.9 cm for female farm workers with average popliteal height and buttock popliteal length of 46.2 and 45.3 cm for male and 40.3 and 40.5 cm for female. The standard deviation for popliteal height and popliteal length were 4.4 and 1.9 for male and 2.7 and 3.8 for female farm workers, respectively. Comparison of data for male farm workers of the present investigation showed slight variation from the data obtained by Gupta et

al (1983), Gite and Yadav (1983), and Yadav *et al.* (1997).

Span and Hip Breadth Sitting

The range of span and hip breadth sitting for male farm workers was 152 to 195 cm and 23 to 45 cm and 130 to 165 cm and 21 to 44 cm for female. The 5th, 50th and 95th percentile for span and hip breadth sitting were 155.7, 175 and 190 cm and 25, 33 and 42 cm for male with covariance of 6.5 and 16.3 cm and 142, 155 and 164.3 cm and 22, 29 and 39.8 cm with covariance of 5.1 and 19.4 cm for female farm workers. The standard deviation in span was 11.4 cm and 7.6 cm, respectively, for male and female farm worker with standard deviation of 5.6 and 5.7 cm for hip breadth sitting for both (male and female).

Functional Leg Length and Palm Length

The functional leg length and palm length for male farm workers ranged from 87 to 118 cm and 7 to 11 cm with covariance of 10.2 and 11.0 cm and, for female farm workers, from 82 to 103 cm and 8 to 11 cm with covariance of 6.8 and 0.9 cm, respectively. The percentiles (5th, 50th and 95th) for the functional leg length of males were 90, 100 and 117 cm and 8, 10 and 11 cm for palm length for male farm workers with standard deviation of 10.6 and 1.0 with averages of 103 and 9.5 cm. However, percentiles (5th, 50th and 95th) for functional leg length and palm length of females were 83, 94.5 and 99.8 cm and 8, 9 and 4.8 for palm length for female farm workers with a standard deviation 5.4 and 0.8 with averages of 93.4 and 9.3 cm, respectively.

Foot Length, Manton to Top of Head and Eye Height

The values for foot length, manton to top of head and eye height ranged from 18 to 25 cm, 16 to 24 and 143 to 170 cm, respectively, for male and 20 to 25, 16.5 to 20.5 and

121 to 159.5 cm, respectively, for female farm workers. The standard deviation and average values for male farm workers were 3.1, 2.1 and 9.2 cm, respectively, for foot length, manton to top of head and eye height while, for female farm workers, the values were 1.4, 0.9 and 7.3 cm, respectively. The 5th, 50th and 95th percentile values for foot length, manton to top of head and eye height of male farm workers were 19, 22 and 25 cm, 17, 20 and 23.5 cm and 143.7, 152.05 and 169 cm. For females the values were 20.6, 22.5 and 24.4 cm, 17.5, 19 and 20 cm and 128.1, 140.0 and 145.8 cm. The covariance values for male farm workers were 12.9, 10.1 and 5.9 cm and 6.2, 4.6 and 5.3 cm for female, respectively, for foot length, manton to top of head and eye height with an average of 24.2, 20.3 and 155.7 for male and 22.4, 18.8 and 138.9 for female, respectively.

Conclusions

The anthropometric data related with 72 body dimensions were recorded for 102 male and 26 female farm workers. Out of them only major dimensions were taken in to consideration.

All the major body dimensions were much closer to the analysis of Indian researchers except the chest circumference (89.3 cm), which was slightly higher than the farm workers of western and southern part of the country.

The 5th and 95th percentiles of dimensions of different anthropometric analyses would be helpful while designing the farm implements and machines to provide comfort and better work efficiency to the user.

Anthropometric analysis correlate perfectly with tractor operator's work place layout as per IS-12343: 1998 test code.

REFERENCES

- Chandra, M. P. 2006. Ergonomic studies of farm workers for the design of farm implements and machines. Thesis, M. Tech., Department of Farm Machinery and Power Engineering, College of Agricultural Engineering and Technology, Allahabad Agricultural Institute- Deemed University, Allahabad.
- Gite, L. P. 1992. Optimum handle height for animal drawn blade harrow, *J. Human Ergology*, 10.
- Gite, L. P. 1991. Optimum handle height for animal drawn mould board plough, *App. Ergonomics*, 22: 21-28.
- Gite, L. P. 1993. Ergonomics in Indian Agriculture-A review paper presented in the international workshop on human and draught powered crop productions held on Jan. 19-22 at Harare (Zimbabwe).
- Gupta, P. K., A. P. Sharma, and M. Gupta. 1983. Anthropometric survey of Indian farm workers, *AMA*, 14: 27-30.
- Kaul, R. N. and W. E. Splinter, 1964. The mass-mechanic concept as a guideline to introduction and development of small implement in India. Paper presented at annual meeting of ASAE, No. 64-120.
- Lehman, G. 1958. Physiological basis of tractor design. *Ergo.* 1(3): 197-206.
- Sen, R. N., P. K. Nag, and G. G. Rey. 1977. Some anthropometric of the people of Eastern India. *J.I. Anthrol Soc.*, 12: 201-208.
- Varma M. R. 1970. Tractor seat design, fabrication and testing. Thesis, Unpublished M. Tech. submitted to Indian Institute of Technology, W. B. Kharagpur. ■■

NEWS

◇ AMA Achieves Impact Factor of 0.0542

Thomson Reuters, an information service company handling academic resources, has rated the impact factor for the publications in 2011. Among the other publications, AMA has at last won the impact factor of 0.0542. Regarding the other agricultural engineering magazines published in the world, this score is rather low. However, since most of the English magazines published in Japan do not have their impact factor rated, this should be a good news for all the people involved in AMA. Yoshisuke Kishida, President of AMA is looking forward to improve the score and strengthen the power of influence.

◇ The Y.Y. Kishida Prize for Dr. Mohammad Badrul Masud

Asian Institute of Technology (AIT) has announced prize awardees related to the institute. Dr. Mohammad Badrul Masud was chosen as the recipient of the Y.Y. Kishida Prize in recognition of his outstanding academic performance in the field of Agricultural Systems and Engineering. The Y.Y. Kishida Prize was established in 1992 by Mr. Yoshisuke Kishida, president of AMA, in memory of his son, Yoshiyuki.

Dr. Masud, a Bangladeshi, obtained his M.Sc. degree, major in Irrigation and Water Management from Bangladesh Agricultural University, Bangladesh in 2009. Dr. Masud was admitted to the AIT Master's program in August 2010 and completed his M.Eng. degree with a thesis entitled "Projected Changes in Climate Extremes Over North Thailand."

Design and Development of Onion Detopper



by
Vijaya Rani
Assistant Professor,
Department of Farm Machinery &
Power Engineering,
Haryana Agricultural University, Hisar
INDIA
vizayarani@yahoo.com

A. P. Srivastava
National Coordinator (NAIP),
ICAR, 319 KAB -II,
Pusa Campus, New Delhi
INDIA
srivastava_ap@rediffmail.com.

Abstract

Onion is one of the most important vegetable crops grown in India. It is grown in an area of 0.48 million ha producing 5.46 million tones of bulbs for local consumption as well for export. Harvesting of onion at correct maturity is a very important factor in the storage life of onion, as the bulbs may be stored for six months. Both operations i.e, digging and top removal are done manually, which is very tedious, time consuming and costly. Besides, it is necessary to complete the harvesting operation within specified time limits. Therefore, an onion detopper was designed and developed. It consisted of a chute type feeding unit, a belt conveyor, an oscillating conveyor, rotating fingers and a rotating cutter. The units were mounted on a main frame. An electric powered transmission system drove all moving components. The onion bulbs were fed through a chute type feeding unit to the belt conveyor that ensured uniform transport of the bulbs to an oscillating conveyor. The belt conveyor had two rollers and an endless conveyor belt moving at a speed of 0.53 ms^{-1} . The oscillating conveyor had a frame, round rods and a crank mechanism to facilitate downward orientation of onion leaves. Provision to vary the oscillator slope and speed was

also provided. The bulbs with leaves in downward orientation passed through rotating cutters. The cutter was provided at the downward side of the oscillating conveyor so that the cutting could be done from beneath without damaging the bulbs. The speed of the cutter could be varied. Output capacity was 300 kg/h and the detopping efficiency 79 %.

Introduction

In the recent years, the importance of consuming vegetables for the maintenance of normal health has been realized in all parts of the world. India is the second largest producer of onions next to China, with an annual production of 5.46 million tones. It accounts for more than 60 % of the total export of fresh vegetable crops. Traditionally, the bulbs are left in the field after digging for about a week for drying after which the tops are removed and the crop is left in the shade again for curing for about a week. Drying and curing are two important processes in harvesting of onion. The purpose of drying the onions with the top after pulling from the ground is to remove excess moisture from the outer skin and necks of the onion in order to reduce the infection of disease causing organisms while minimizing the shrinkage caused by

removal of moisture from the interior. Curing is an additional process after detopping. Curing aids in the development of skin color and also is practiced to remove field heat before bulbs are sorted. If tops are cut too close, the neck does not close well and decay organisms have easy access to the bulb. Early harvest results in sprouting of the bulbs and late harvest results in formation of secondary roots during storage.

Even though India ranks second in area and production of vegetables, the productivity is still quite low. One of the main reasons for low productivity is the high labor requirement, which can be overcome by increased mechanization. Also, there are high post harvest losses, which are due to unawareness of the farmer's with appropriate technologies for post harvest management. Harvesting of onion at the stage of maturity is a very important factor in deciding storage life of the onion, as the bulbs may be stored for about six months. Both digging and top removal are done manually, which is very tedious, time consuming and costly. Besides, it is necessary to complete the harvesting operation within specified time limits. To overcome these difficulties, it has become necessary to mechanize the onion harvesting process.

Mozaffary *et al.* (2004) designed, developed and tested three onion

toppers (flail, rotary and counter-rotating rollers). The flail topper was the most efficient with 87.7 percent maximum acceptable tops at 2,000 rpm. Although a number of onion harvesters have been developed, very limited information is available regarding mechanical detopping. This study was undertaken with the main objective to design and develop a simple, low cost onion detopper.

Materials and Methods

The onion detopper consisted of a feeding unit, conveying system, cutting unit, main frame and power transmission system. The conveying unit used a belt conveyor, oscillating conveyor and rotating fingers.

The design of these components is discussed in subsequent sections.

Feed Hopper

The feed hopper was designed according to the Bureau of Indian Standards guidelines on feeding chute for threshers (IS: 15: 9129-1979). Design criteria for the feed hopper presented by Naravani (1991) were followed. The following expression was used for determining holding capacity of the hopper.

$$v \geq w / r,$$

where

v is the volume or holding capacity of the feed hopper, m^3

w is the quantity of onion crop fed into the feed hopper during each filling, kg

r is the bulk density of the onion crop, kg/m^3

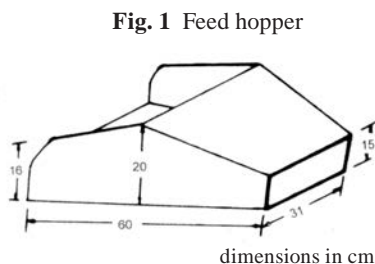

For ensuring smooth and continuous flow of the onion crop from the hopper to the oscillating conveyor the following conditions had to be satisfied:

$$\theta_h \geq \theta,$$

where

θ_h is the angle of inclination of the feed hopper to the horizontal, degrees

θ is the angle of friction, degrees

The feed hopper was fabricated from 18 gauge mild steel sheet. Details of the feed hopper are included in Fig. 1.

Belt Conveyor

The belt conveyor (Fig. 2) was provided for uniform feeding of the onion crop to the oscillating conveyor. The belt conveyor included two rollers and an endless conveyor belt of canvas material. The diameter of the rollers was 100 mm and the length of belt was 1,600 mm. The conveyor belt moved on the rollers and carried the crop to the oscillating conveyor. Changing the speed of the belt conveyor changed its capacity.

The material handling capacity of the conveyor belt was calculated as (Klenin *et al.*, 1985)

$$q'_{st} = \gamma L h u_{con},$$

where

q'_{st} is the material handling capacity, $kg\ s^{-1}$

γ is the density of the standing crop, $kg\ m^{-3}$

L is the length of the standing crop, m

H is the height of the stalk layer on the conveyor at delivery, m

u_{con} is the speed of the conveyor, $m\ s^{-1}$

The speed of the belt conveyor should be such that it should be able to handle the material fed to hopper, and convey it to the oscillating conveyor uniformly without choking it or conveying less material than the capacity of the oscillating conveyor. Preliminary studies were conducted for determining the speed of the belt conveyor. The speed of the belt was fixed at 0.53 m/sec after the studies.

Oscillating Conveyor

The detopper was provided with an oscillating conveyor. The basic requirement of this conveyor was to orient the onions with leaves in a downward direction so that cutting could be done from beneath without damaging the bulbs. It was the most critical component of the detopper as the performance of the detopper largely depended on the design of the oscillating conveyor.

The oscillating conveyor had a frame, round rods and crank mechanism. The rods (8 mm diameter) were placed longitudinally with 25 mm spacing between them, which would facilitate desired orientation of the leaves. The onion leaves, in downward direction, moved into the space between the rods and moved along the length to the cutting unit. The distance between the rods was less than the diameter of the smallest onion. The frame of the oscillating conveyor was connected to a connecting rod so that the oscillating motion of the conveyor was provided by an eccentric crank

Fig. 2 Top view of onion detopper

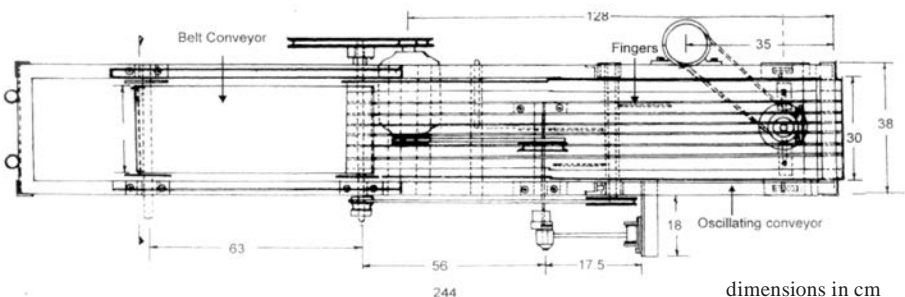

mechanism.

The important parameters determining the conveying efficiency of the oscillating conveyor were its slope, length and speed of oscillations and spacing between rods. Provision was made to vary the slope and speed of oscillations. Slope of the oscillating conveyor was varied with two screw jacks mounted on the main frame.

The frame was fabricated from 40 × 40 × 6 mm mild steel angle iron and was mounted on the main frame on roller bearings to provide smooth oscillations. The mild steel round rods 8 mm diameter were fixed on the oscillating conveyor frame. The stroke length of the crank was 25 mm. The oscillation of the conveyor could be varied from 400 to 600 rpm. The details of the oscillating conveyor are shown in Fig. 2.

Fingers

During movement of the crop on the oscillating conveyor some of the tops were not oriented in the downward position. Some tops were laterally placed and could not get into the spacing between rods. Such bulb tops moved laterally. The rotating fingers were therefore provided to pull the tops of the onion crop through the gap between the rods fixed on the oscillating conveyor. The length of these fingers was such that it just pulled the tops down through the rods on the oscillating conveyor without disturbing the mo-

tion of the onions to the cutting unit. The speed of the fingers was 0.23 m/sec. The 160 mm long fingers were made of 2 mm diameter mild steel rod and were mounted on a shaft at a distance of 65 mm. The position of the fingers can be seen in Fig. 2.

Cutting Unit

The cutting unit (Figs. 3 and 4) was required to cut away the top of the onions. It was designed to cut the leaves with minimum damage to the bulb. A rotary cutter consisted of two blades and was positioned below the oscillating conveyor towards the rear end. When the onion bulbs with tops in the downward position reached the rear end of the oscillating conveyor, the tops became detached from the bulb by the rotating blades of the cutter. The blades were 75 × 45 × 1 mm flat mild steel. For efficient cutting of unsupported stalks, the cutter speed of between 6 and 10 m/sec was recommended (Klenin *et al.*, 1985).

The power required to overcome the forces of resistance to the motion of the knife was obtained from Klenin *et al.* (1985)

$$A = (P \times v) / 1000,$$

where P is the resistive force,
v is the knife speed, m s⁻¹

The details of the cutting unit are given in Fig. 3.

Main Frame

The main frame was fabricated from 40 × 40 × 6 mm mild steel

angle iron for mounting the hopper, belt conveyor, oscillating conveyor, blades, fingers and electric motor. The length, width and height of the main frame were 2,440, 300 and 600 mm, respectively. The feeding, oscillating and cutting units were assembled on the main frame. The overall length, width and height of the machine were 2500 × 600 × 1350 mm.

Power Transmission System

The belt conveyor, oscillating mechanism, fingers and cutter provided motion for the conveying onion crop from the feeding hopper to the cutter. The belt conveyor moved in a clockwise direction. The oscillating conveyor was given oscillations with belt, pulley and cam. The fingers provided motion via belt and pulley in a counter-clockwise direction. The cutter was driven by a belt and pulley. Power was provided by two a.c. electric motors. The two a.c. motors were used for the experimental testing of the detopper. However, in the final prototype only one motor was used. A 1.5 horse power, three phase a.c., 925 rpm motor was used to drive the belt conveyor, oscillating conveyor and fingers. A 2.0 horse power, single phase 1,440 rpm motor was used to drive the cutter.

The onion detopper prototype was developed and tested at the Indian Agricultural Research Institute, Delhi in the Division of Agricultural Engineering. The tests on the experimental detopper were conducted on onion variety NP -53. The studies on crop-machine variables relevant to

study were conducted at the maturity stage of the onion crop. The average moisture content of the bulb for small, medium and large bulbs was 85.76, 86.72 and 85.66 percent, respectively. The average moisture content of the tops was 76.99, 72.20 and 71.60, respectively, percent for small, medium and large size bulbs.

Fig. 3 Details of cutting unit

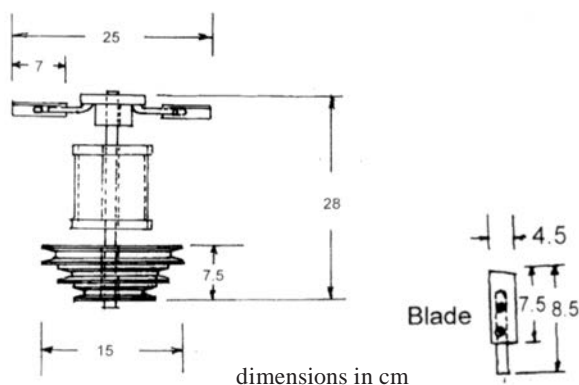

Fig.4 Rotary cutter

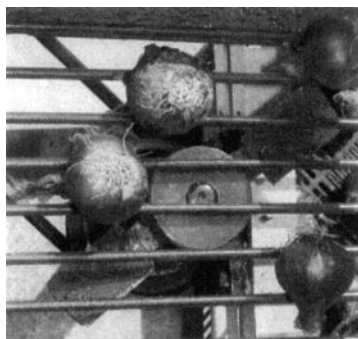

Table 1 Plan of experiment on onion detopper

Level of variables		Performance parameter
Oscillating conveyor	Slope, degrees - 1.0,1.5 and 2.0 Oscillation, rpm- 400, 500 and 600	Conveying efficiency Cutting efficiency
Cutter	Blade, rpm -500, 1000 and 1500	Height of cut Total losses
Crop size	Small- < 40 mm Medium- 40 to 60 mm Large- >60 mm	Detopping efficiency

Plan for Evaluation of the Final Prototype

The final prototype was evaluated as planned in **Table 1**.

The performance of the final prototype onion detopper with the recommended specifications was evaluated and performance and economics were compared with manual detopping.

1) Conveying Efficiency:

The efficiency of the oscillating conveyor was calculated to determine how well the onion crop was conveyed with tops in the downward position. It was defined as follows:

$$\text{Conveying efficiency, \%} = [a / (a + b)] \times 100,$$

where

a is the total number of onions conveyed to cutter with onion tops in downward position

b is the total number of onions conveyed to cutter with onion tops not in downward position

The conveying efficiency was measured by counting the total number of onion bulbs fed into hopper and total number of onion bulbs reaching the cutter with tops in downward position through the rods fixed on the oscillating frame.

2) Cutting Efficiency:

Cutting efficiency was calculated as follows.

$$\text{Cutting efficiency, \%} = (c / a) \times 100,$$

where

c is the total no of onion tops cut by the cutter

a is the total number of onions conveyed to cutter with onion tops in downward position

Cutting efficiency was calculated by counting the number of onion tops reaching the cutter with tops in

a downward position and the number of onions cut by the cutter.

3) Detopping Efficiency:

Detopping efficiency indicated overall efficiency of the machine.

$$\text{Detopping efficiency, \%} = [\text{Conveying efficiency (\%)} \times \text{Cutting efficiency (\%)}] / 100$$

4) Height of Cut:

The height of cut was measured for each onion bulb in the treatment by a measuring scale and average height of cut.

5) Total Losses:

The losses due to machine detopping were compared with manual detopping of onion leaves. The onion bulbs after detopping were kept in an onion storage shed of the Division of Agricultural Engineering at IARI, New Delhi. The weights of the bulbs under different treatments were taken after three weeks of stor-

age.

Results and Discussion

The combination of the values of the variables; size of onion bulb, speed and slope of the oscillating conveyor and blade speed for optimum height of cut influenced the performance of the detopper: **Table 2**.

From **Table 2**, the mean conveying efficiency was 94.57, 89.38 and 83.70 percent for small, medium and large of onion bulbs, respectively. It was observed that the conveying efficiency decreased with increase in size of the onion bulb, slope and frequency of oscillations. The cutting efficiency decreased with increase in slope and speed of oscillation. It increased with increase in blade speed. The mean cutting efficiency for small, medium and large sizes of onion bulbs was 96.73, 95.56 and 95.12 percent, respectively. The detopping efficiency decreased with increase in slope and frequency of oscillations of the conveyor. As the size of the onion bulbs increased the detopping efficiency decreased. The detopping efficiency increased with

Table 2 Marginal mean at different Level of variables

level of variables	Marginal mean			
	Height of cut, cm	Conveying efficiency, %	Cutting efficiency, %	Detopping efficiency, %
Slope, degrees				
1.0	1.93	91.60	99.01	90.81
1.5	2.04	90.12	95.49	86.35
2.0	2.08	85.93	92.90	79.26
Size of bulb, mm				
< 40	1.64	94.57	96.73	91.40
40 - 60	2.15	89.38	95.56	85.42
> 60	2.26	83.70	95.12	79.59
Blade speed, m/sec				
8	1.90	NA	92.96	81.36
10	2.01	NA	97.16	87.65
12	2.14	NA	97.28	87.41
Oscillation, strokes/sec				
12	1.93	91.11	97.96	89.18
16	2.02	93.83	95.56	89.63
20	2.10	82.72	93.89	77.60

increase in blade speed. The total loss due to machine and operational parameters was less than 5 percent. This low level of loss was essentially due to the fact that the onion bulbs did not come in contact with the rotating blades. The height of cut was significantly influenced by slope, blade and oscillating speed and size of bulbs. The height of cut increased with slope. The height of cut increased with increase in blade speed and frequency of oscillations at all combination levels of variables.

The slope of 1.0 degree, blade speed of 1000 rpm and speed of oscillation 500 rpm were recommended for the final prototype for all the three sizes of onion bulbs at harvesting stage.

Based on above results a final prototype was designed and evaluated at this optimum set of variables. The unit is shown in **Fig. 5**. It gave a height of cut 22 mm, detopping efficiency 79 % and damage of 2 %. The capacity of the detopper was 3.0 q/h and cost of operation 29.62 Rs/h.

Fig. 5 Onion detopper (Front view)

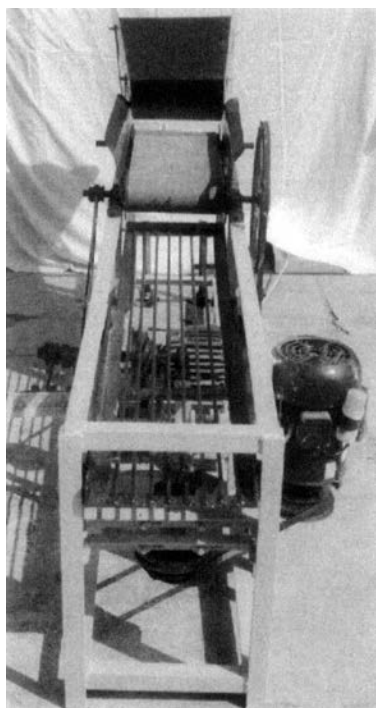

The cost of detopping per quintal with the prototype and conventional method was Rs 9.87 and 15.37, respectively. The saving in the cost of detopping of a quintal of onion crop with the use of the detopper was Rs 5.50, 35.77 percent of the cost associated with conventional method. The break-even point for the onion detopper was 88.51 hour, which was 44.26 percent of the annual utility. The pay back period of onion detopper was 1.80 year.

Conclusion

The overall performance of the machine for all sizes of onion bulbs was best at a slope of 1.0 degree, blade speed of 1,000 rpm and oscillation of 500 rpm. Height of cut of onion top, detopping efficiency, damage, capacity and cost of operation was 22 mm, 79 %, 2 %, 300 kg/h and 29.62 Rs/h, respectively.

REFERENCES

- Indian standards. 1979. Technical requirements for safe feeding system for power threshers. 15:9129-1979. Indian Standards Institution, New Delhi.
- Klenin, N. I., I. F. Popov, and V. A. Sakun. 1985. *Agricultural Machines. Theory of operation, computation of controlling parameters and the conditions of operation.* Amerind Publishing Company Private Limited. New York.
- Mozaffary, M., K. Kazmainkhah, S. A. Mousavizadeh, and S. Abdi. 2004. Design and development of three onion toppers and selection of the best one for an onion harvester. 1-East Azarbaijan Research Center for Agriculture and Natural Resources, Tabriz-Iran.
- Naravani, N. B. 1991. Studies on design and operation parameters of sunflower and safflower threshing. Unpub. Thesis. IARI, New Delhi. ■■

Adoption of Skill Enhancement Techniques and Quality Improvement in Manufacturing of Agricultural Implements in Madhya Pradesh, India

by
Dushyant Singh

K. P. Saha



S. P. Singh

Central Institute of Agricultural Engineering
Nabibagh, Berasia Road, Bhopal, INDIA

Abstract

A study was conducted to ascertain the extent of use of different sources of information for product identification, improvement of skill and production techniques for agricultural implements, the expectations of manufacturers and the constraints faced and the adoption of improved manufacturing practices. Information was collected on a sample of 118 manufacturers from 18 districts of the state of Madhya Pradesh in Central India. The study revealed that the large category manufacturers with the largest establishment and highest turnover of more than Rs. 4 million were in a advantageous position with easy access to information, strong linkages with government agencies, initiatives taken for improvement of skills and production technologies and higher investment capability. This enabled them to obtain the lion's share of the market as compared to small and medium firms manufacturing agricultural implements.

Introduction

In India, agricultural implement manufacturing is a significant segment of the small scale manufacturing sector. The agricultural implement manufacturing activity in registered small scale industries is comprised of 28 clusters spread over 7 states; i.e. Punjab, Rajasthan, U.P. West Bengal, M.P., Gujarat and Karnataka. According to the third All India Census for Small Scale Industries (2001-02), there were 18354 units engaged in agricultural implement manufacturing activity with a gross output of 6,632.4 million per annum. This segment also provided employment to about 45 thousand persons and generated foreign exchange of about 69 million US\$ through export of agricultural implements (Arora, 2005). Apart from this, a larger number of agricultural implement manufacturing units belong to the unregistered small-scale industry segment. Though their average gross output and earning from export is less than that of the registered segment, they still play a significant role in providing employment to a large component of skilled

manpower.

The agricultural implement manufacturing industries in the state of Madhya Pradesh, located in Central India, mainly belongs to an unorganized or semi-organized sector, along with rural craftsmen and artisans; mostly manufactures of conventional agricultural implements and hand tools. However, with the rapid modernization of the agricultural sector and mechanization of farm operations, new and improved agricultural implements are coming into the picture as an outcome of sustained research and development efforts (Singh and Saha, 2006). Therefore, the manufacturers have taken up the production of such agricultural implements to meet the demand. However, without any of their own research and development activity, they are mostly dependent on the government research organization and their extension services for getting information on such development. Sometimes they also rely upon the direct feedback collected from their customers; i.e. farmers, for identification of new implements to be manufactured. The socio-economic profile of the manufacturer

also governs access to available information, linkage with government organizations, capability of continuous improvement in human skills and adoption of new manufacturing technologies to survive in an era of aggressive competition.

It is important to examine the access to information of the manufacturers for product identification and development, their expectation of cooperation from government research and development organizations, capability for skill improvement and quality upgrading and adoption of new manufacturing technologies for agricultural implements.

Materials and Methods

The state of Madhya Pradesh has 50 districts out of which 18 districts were randomly selected. A total of 118 manufacturers participated in the study and responded to the correspondence. The data were collected from the manufacturers on their socio-economic profile, types of implements manufactured, constraints faced in the business, access to information sources, linkages with and aspirations from government organizations, skill improvement, quality upgrading techniques and adoption of improved manufacturing practices by using a pre-tested proforma through direct personal interviews.

of the total population. Medium and large manufacturers contributed 36 percent and 17 percent to the total population of manufacturers of agricultural implements.

The average floor area of the production workshop for different categories of manufacturers is presented in **Fig. 2**. With an increase in the business turnover, the size of manufacturing yards have been increased by many times.

The average number of regular employees and the manufacturing experience of the manufacturers in years are shown in **Fig. 3**. The large manufacturers employed more skilled workers for scaling up the production as compared to small and medium manufacturers though the average manufacturing experience among different category of manufacturers was similar.

The different types of agricultural implements manufactured by these manufacturers are described in **Table 1**. The manufacturers focused more on the commonly tractor operated implements like the cultivator, seed drill, thresher and trailer with an increase in business volume. The same trend was observed for other tractor operated implements like the mouldboard plough, disc harrow, land leveller and reaper. However, the manufacturing of such implements was given less priority by

Fig. 1 Percentage of manufacturers in Different Categories

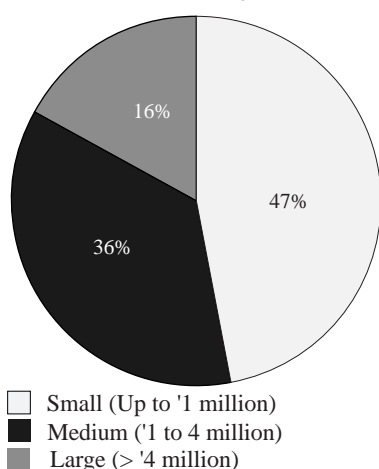

Results and Discussion

All the manufacturers covered in this study were divided into three groups according to their annual turnover in rupees; i.e. small (having annual turnover less than 1 million rupees), medium (annual turnover between 1 to 4 million rupees) and large (more than 4 million rupees). The distribution of the manufacturers into different categories of annual turnover is depicted in **Fig. 1**. The small manufacturers were in the majority with 47 percent share

Fig. 2 Average floor area (m²) for different categories of manufacturers

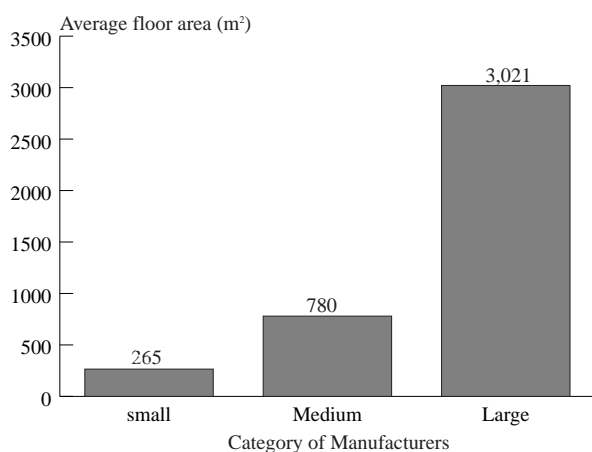

Fig. 3 Average number of regular employee and manufacturing experiences (years) of the manufacturers

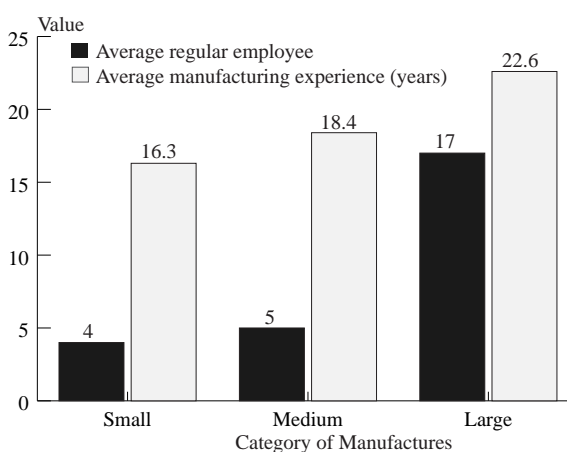

Table 1 Types of agricultural implements being manufactured

Name of the implement	Percentage of manufacturers taken up		
	Small	Medium	Large
Tractor drawn mouldboard plough	27.3	46.5	60.0
Tractor drawn cultivator	81.8	90.7	95.0
Tractor drawn disc Harrow	10.9	16.0	25.0
Tractor drawn land leveller	9.1	28.0	35.0
Tractor operated Seed drill	63.6	88.4	95.0
Tractor operated reaper	7.3	9.3	15.0
Tractor / power operated thresher	63.6	72.1	95.0
Tractor Trailer	63.6	79.0	90.0
Animal drawn plough	3.6	2.3	5.0
Animal drawn seed drill	21.8	13.9	5.0
Bullock cart	20.0	-	5.0
Manually operated weeder	10.9	9.3	-

Table 2 Constraints faced by the manufacturers

Type of constraints faced	Small	Medium	Large
Shortage of electricity supply	94.55	93.02	85.00
Shortage of working capital	92.73	88.37	40.00
Lack of continuous demand / seasonal demand	89.09	81.40	60.00
Lack of technical know-how and tools	78.18	79.07	30.00
Marketing problems	76.36	76.74	40.00
Management problems	60.00	39.53	70.00
Labour related problems	50.91	48.84	70.00
Non-availability of raw material as per quality or time	45.45	44.19	20.00

Table 3 Access to information for identification of new product

Source of information	Access by percentage of manufacturers		
	Small	Medium	Large
Electronic Mass Media	0.00	2.33	5.00
Print Media	16.36	18.60	40.00
Farmers' / Clients' Feedback	89.09	83.72	85.00
Government Extension Services	5.45	6.98	35.00
Dealers	0.00	0.00	25.00
Farmers' Fair / Agri. Expo	38.18	44.19	70.00
Internet and worldwide web	0.00	0.00	5.00

Table 4 Linkages and expectations from government organizations

Particulars	Small	Medium	Large
Guidance for development of new machines	9.09	16.28	40.00
Technical support for product improvement	10.91	16.28	50.00
Training for skill improvement of workers	50.91	72.09	85.00
Material and product quality testing	5.45	6.98	75.00
Standardization of the developed implement	0.00	2.33	40.00
Certification of the developed implement	5.45	6.98	70.00

most of the manufacturers, as these were less preferred implements for the farmers of this region. The manufacturers rarely preferred the manufacturing of animal drawn implements due to very low demand.

The manufacturers of agricultural implements have expressed a diversified opinion regarding constraints. The majority of the small and medium manufacturers identified the interruption in electricity supply, shortage of working capital, lack of adequate demand, lack of technical know-how, tools for sophisticated manufacturing techniques and marketing problems for new implements as major constraints faced in the business. The large manufacturers were only concerned about erratic electricity supply, management of business in highly competitive markets and labour problems in terms of supply and cost of skilled manpower in their day to day business (**Table 2**).

The level of awareness among the manufacturers for using information as a tool for business promotion was very limited. The use of electronic and print media for accessing the information is quite low as only a few manufacturers of medium and large category use such sources. Most of the manufacturers mainly depend on opinion and feedback collected from the clients and farmers and occasional visits to agricultural expo and farmers' fairs organized in their locality for getting exposure to new and improved agricultural implements. Sometimes large manufacturers gather information from extension services of government departments and network of dealers supplying agricultural machinery to the farmers (**Table 3**).

During interaction, the expectations of the manufacturers of agricultural implements from government agencies were discussed. The willingness of the manufacturers for establishing linkage with government agencies for various developmental purposes was also examined.

Table 5 Improvement of skills and quality up-gradation for products

Particulars	Small	Medium	Large
Products manufactured on the basis of drawing	0.00	0.00	33.33
Loan taken for investment on scaling up of production	3.64	11.63	80.00
Willingness to enhance the production capacity of the workshop	3.64	9.30	75.00
Certificate / test report acquired for developed products	1.82	4.65	75.00
Implements testing conducted before marketing	5.45	6.98	75.00
Trainings arranged for the skilled workers	0.00	2.33	30.00

Table 6 Adoption of improved production technologies

Particulars	Small	Medium	Large
Arc welding set	100	100	100
Gas welding	45.4	48.8	66.7
Electric Portable drill	90.9	95.3	100.0
Bench drill	41.8	41.9	80.0
Pillar drill	12.7	23.3	95.0
Radial drill	0.0	4.7	35.0
Portable grinder	87.3	69.8	80.0
Bench grinder	9.1	18.6	100.0
Lathe machine	61.8	62.8	85.0
Hand saw	10.9	20.9	10.0
Power saw	18.2	41.9	75.0
Power Press	36.4	58.1	90.0
Compressor	7.3	37.2	60.0
Furnace	16.4	27.9	55.0
Bending machine	5.5	16.3	55.0
Profile machine	0.0	0.0	15.0
Shaping machine	1.8	11.6	55.0
Hand Shearing machine	25.5	11.6	30.0
Spray painting gun	38.2	51.2	70.0
Milling machine	1.8	11.6	90.0

It can be seen from **Table 4**, that small and medium manufacturers show little willingness for taking guidance and technical support for development of new machines or product improvement. The inclination of large manufacturers towards these activities was considerably higher. This may have been because of availability of limited resources and very low market share for the small and medium manufacturers. The majority of the manufacturers from all categories were eagerly interested in obtaining training of their workers with government agencies. This results further pointed out that only large manufactur-

ers were interested for material and product quality testing, standardization of the developed implements, and certification of the developed implements because they have a large market share. Sometimes this becomes necessary in getting their products subsidy from governments for supplying to the farmers through agro-industrial development corporations of various states.

Table 5 clearly shows that only large manufacturers are interested in improvement of skill and quality up gradating of products as they have better infrastructure, higher annual turnover, market reputation and higher investment capacity.

These are the factors that make the large manufacturers capable of enhanced production capacity in their workshop. They are also capable of taking a loan for scaling up of production capacity and employ skilled manpower with ability to manufacture the implements on the basis of a design drawing while, the small and medium manufacturers only use a sample piece to make the similar machines. Hiring of skilled manpower is out of reach of the small and medium manufacturers. Some large manufacturers have large farmlands (on ownership or hiring basis) for testing of their implements, whereas small and medium manufacturers cannot afford this. As a consequence, improvement of skills and quality upgrading of manufactured products is taken up only by the large manufacturers.

Examining the extent of adoption of improved production technologies reveals that common workshop tools like arc welding, drilling machine and grinders are commonly available with most of the manufacturers of all categories. However, the adoption of specific types of tools is solely governed by the manufacturing capacity. The table also shows that some high capacity machines like a lathe, power press, compressor, saw and spray painting gun were used by the manufacturers. Sophisticated facilities like a milling machine are available with a majority of large manufacturers but small and medium have their milling work done by outside sources (**Table 6**). Overall, manufacturers across different categories have adopted varying levels of improved manufacturing practices as per their requirement.

Conclusions and Suggestions

It can be concluded from the study that the size of a manufacturing unit and its annual turnover is the sole

crucial factor determining the extent of access to information sources, linkage with research and development organizations, skill improvement and quality up grading for developed products. However, exposure to improved technical know-how through trainings and manufacturers meeting with research organizations and support from the government in terms of subsidizing improved implements suitable for marginal and small farmers may

also be helpful for a large number of small and medium manufacturers of agricultural implements.

REFERENCES

Arora, R. K. 2005. Diagnostic Study Report on the Agricultural Implement Industry at Karnal (Haryana). Small Industries Service Institute, Kunjpura Road, Karnal-132001 (Haryana).

Singh, D. and K. P. Saha. 2006. Final Report on Survey of Manufacturers of Agricultural Implements for Preparation of Directory of Commercially Available Agricultural Equipment and their Manufacturers. Central Institute of Agricultural Engineering, Bhopal, India.

Directorate of Research on Women in Agriculture: Sub-centre (ICAR) CIAE Campus, Nabi Bagh, Bhopal- 462 038. ■■

ABSTRACTS

The ABSTRACTS pages is to introduce the abstracts of the article which cannot be published in whole contents owing to the limited publication space and so many contributions to AMA. The readers who wish to know the contents of the article more in detail are kindly requested to contact the authors.

1247

Power-Efficient Method of Tillage and Its Technology Model: A. Tukhtakuziev, Republic of UZBEKISTAN; A. N. Khudoyorov, same.

At present time soil tillage for sowing and crops preparation are mainly put into practice by means of traditional technologies and engineering tools, that is plowing firstly, harrowing and leveling secondly, after which ridges are cut. Such multi-step tillage provokes big labor inputs, expenditure of energy and fuel, delays sowing time that results in yield drop of agriculture.

On the assumption of the above-stated we have developed a new tillage technology model for cotton-plant sowing and a component unit for its implementation.

The engineered unit is composed of (Fig. 1) chassis 1 with mounted element 2, rippers 3, fertilizer plows 4, ridge-forming tools 5, chemical fertilizers feeder 6 and support wheels 7.

The unit in a run mellows the bottom of the last years' irrigation furrows at a depths of 30-40 cm (Figs. 2a and 2b), moulds the old ridges in furrows, moulds new ridges (Fig. 2c) dressing them with two-layer strip of chemical fertilizers. In that way, the new ridges are cut due to demolition of the old ridges and soil slip to the area of old ridges (Fig. 2a). At the same time a layer of loose soil of 55-65 cm depth is formed as compared to 30-40 cm in the case of plowing. In spring the ridges are touched up and chemical fertilizers are dressed for cotton-plant sowing. Thus there is no need to carry out such traditional operations as harrowing, chisel plowing and leveling. Consequently, fuel consumption and labor inputs are reduced.

Soil tillage is carried out sinusoidally along the frontal projection. Because of this the soil structure is disturbed only once in two years. Loose soil area is formed under

the ridge that ensures moisture keeping in the zone of the plant root system, as well as saving of irrigation water consumption.

Realization of the new tillage technology gives an opportunity to reduce 1,3 - 1,4 times labor inputs and fuel consumption for soil tillage for cotton-plant sowing. ■■

Fig. 1 Component Unit Design

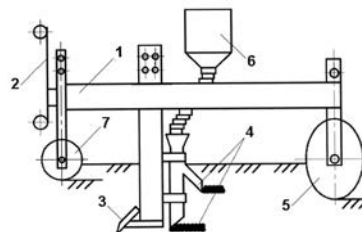
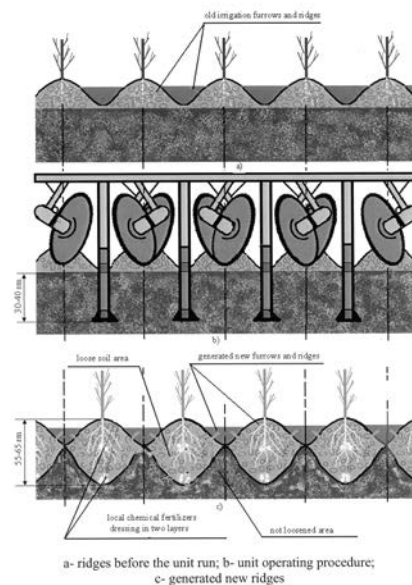

Fig. 2 Component Unit Operating Procedure



a- ridges before the unit run;
b- unit operating procedure;
c- generated new ridges

Flow Characteristics of a Wall-Attaching Offset Jet in a Complete Fluidic Sprinkler

by
Xingye Zhu
Post doctoral fellow

Shouqi Yuan
Professor

Hong Li
Professor

Junping Liu
Ph. D student.

Research Center of Fluid Machinery Engineering & Technology,
Key Laboratory of Modern Agricultural Equipment & Technology,
Ministry of Education & Jiangsu Province,
Jiangsu University, Zhenjiang 212013, Jiangsu, CHINA
zhuxy@ujs.edu.cn

Abstract

An offset jet was used to develop a complete fluidic sprinkler. Although studies of the development and water distribution of this sprinkler have been reported in the literature, the flow field of an offset jet within this sprinkler type has remained largely unexplored. A mathematical model simulating the inner flow of this sprinkler type was established using computational fluid dynamics. Numerical simulations and experimental studies were performed to gain insight into the convective flow characteristics of the sprinkler. A detailed study of the relationship between the flow rate and the pressure in the eddy section, as well as the position of the reattachment region, in this sprinkler type was presented. The average deviation between numerical simulation and experimental results was less than 5 percent. The numerical simulation obtained in this study do reflect the inner flow of a complete fluidic sprinkler.

Introduction

The number of crises resulting from water shortages will continue to increase well into 21st century. As an agricultural country, China must develop water-saving agricultural technologies. Sprinkler irrigation has been used as a major method of water conservation. The sprinkler, which is a key device of an irrigated system, directly impacts irrigation performance. Today, the impact-style sprinkler, which was invented by the Rainbird and Nelson companies in the United States in 1933, is popular all over the world. After the 1960s, the impact sprinkler developed rapidly in America, Russia, and Israel, and has since become used universally in agriculture (Frederick, 2009 and Nelson Irrigation Corp., 2002).

China first started using water-saving devices in 1954. Gan invented the self-controlled step-by-step complete fluidic sprinkler in 1980. In 1981, Fuzhou University invented another complete fluidic sprinkler that controlled itself by feedback. In 1990, Hang *et al.* invented and began selling the double-strike syn-

chronism complete fluidic sprinkler; however, due to several technical problems, it was not successful on the market. In 2005, the Research Center of Fluidic Machinery Engineering and Technology at Jiangsu University invented the PXH-type gap-controlled complete fluidic sprinkler (Zhu and Yuan, 2008). Today, the impact sprinkler is widely used all over the world, but its structure is somewhat complicated. The complete fluidic sprinkler is much simpler than the impact sprinkler and may become a substitute for the impact sprinkler in the near future.

A wall-attaching offset jet can frequently occur in complete fluidic-type sprinklers. Several theoretical and experimental studies have investigated the complete fluidic sprinkler (Yuan *et al.*, 2006 and Zhu *et al.*, 2009); however, no previous research has investigated the flow characteristics of the inner flow. The purpose of this study was to establish a mathematical model for the inner flow of the complete fluidic sprinkler using computational fluid dynamics. The results of the present work provide a detailed description of the flow characteristics in the pre-

attachment region of the complete fluidic sprinkler. Numerical simulation and experimental results are compared. These results should aid in the understanding and modeling of the curvature and impingement effects in complete fluidic sprinklers.

Working Theory

The working theory of the complete fluidic sprinkler primarily depends on the Coanda effect, as depicted in the schematic diagram of the wall-attaching offset jet in **Fig. 1**. When the jet is discharged from nozzle D, there is a reduction in pressure in area I. The jet is forced to deflect towards the boundary and eventually attaches to it. The jet develops in the wall jet region after its reattachment to the wall. This phenomenon is referred to as the Coanda effect (Coanda, 1936).

Numerous studies have investigated the wall-attaching offset jet. Pal-

frey and Liburdy (1986) studied the mean flow characteristics of a turbulent offset jet. Borgue, and Newmawn (1960) studied the mean flow characteristics of a wall-attaching offset jet. Hoch and Jiji (1981) numerically predicted the jet trajectory and jet reattachment length. Song *et al.* (2000) studied the flow and heat transfer characteristics of a two dimensional jet. Wang and Lu (1996) studied the basic theory of the fluidics of wall attachment, although their research was based only on two-dimensional flow. No previous studies in the literature have investigated three-dimensional flows, and, therefore, three-dimensional wall-bounded flows were investigated in this paper.

Figs. 2 and **3a** depict an image and the geometry of the complete fluidic sprinkler, respectively. As shown in **Figs. 3a** areas 1 and 2 widen sharply from nozzle D. PL and PR represent the pressure in the

left and right sides of the sprinkler, respectively. When the jet is discharged from nozzle D, PL and PR are less than atmospheric pressure. When the Coanda phenomenon occurs, the jet impinges upon the sprinkler and causes it to rotate.

The process of sprinkler operation is as follows: water is ejected into the working area from nozzle D. A low-pressure eddy area forms on both sides of the working area. Air flows into the left side from the reversing blowdown nozzle and into the right side from gap C. The main flow jet is straight because the pressures are equal on both sides, and, thus, the sprinkler remains stationary, as shown in **Fig. 3a**. In the meantime, the signal flow that is received from signal nozzle 1 fills up gap C to make the right side a low-pressure eddy. The main flow jet is bent toward the boundary and is eventually attached to it because the left pressure is much larger than the right pressure. The

sprinkler is driven to rotate by the chamfer of the plate cover, as shown in **Fig. 3b**. The main jet flow bends to the right such that signal nozzle 1 cannot receive any flow. As water in the flowing duct is pulled out, the negative pressure between the left and right sides disappears. The main flow jet becomes straight again, resulting in the sprinkler becoming stationary again. This phenomenon is repeated step-by-step,

and the sprinkler achieves a stepwise rotation in sequence by self-control. The reversing blowdown nozzle is filled when the sprinkler step is confined. The main flow jet is reattached to the left plane, and and and the sprinkler rotates to the opposite direction because the right pressure is much larger than the left pressure, as shown in **Fig. 3c**. When the sprinkler rotates to the other side, the reverse blowdown nozzle opens, and air comes into the left side to

Fig. 1 Offset jet flow geometry

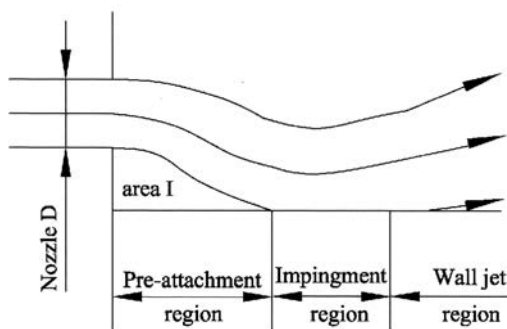

Fig. 2 The complete fluidic sprinkler

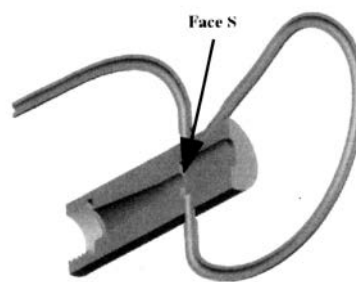
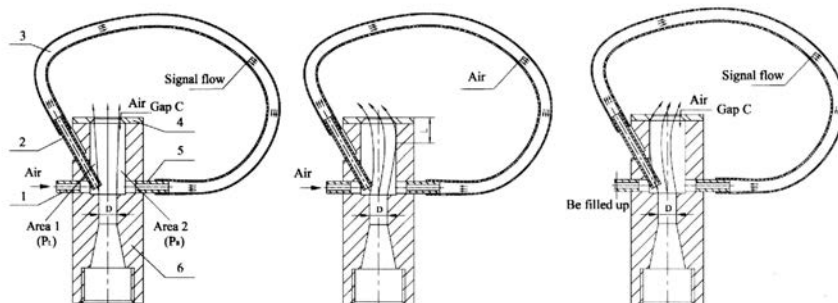

Fig. 3 Statistical conditions of the complete fluidic sprinkler



a) Straight main flow jet. b) Main flow jet reattached to the right side. c) Main flow jet reattached to the left side.

1-Reversing blowdown nozzle, 2-Signal nozzle 1, 3-Flowing duct, 4-Plate cover, 5-Signal nozzle 2, and 6-Fluidic element.

equalize the pressure again. The complete fluidic sprinkler achieves its stepwise rotation in sequence and reversal by self-control.

Materials and Methods

Experimental Setup and Procedure

An experimental investigation of the jet-boundary interaction problem was conducted in an indoor laboratory at the Research Center of Fluid Machinery Engineering and Technology (State of Jiangsu, China). A photograph of the flow system is depicted in **Fig. 4**. **Figs 4a, b** and **c** depict the sprinkler irrigation system, pressure transducer, and wall-attaching offset jet in the sprinkler, respectively. A centrifugal pump was used to supply water to the sprinkler irrigation system from a reservoir maintained at a constant level. The maximum flow rate obtained under this arrangement was approximately 9,180 L/h, with an operating pressure of 500 kPa, which was controlled by a pressure regulator. A lower flow rate was produced by adjusting the valve in the main pipe. The flow rate was measured using a laminar flow element, which was accurate to percent over the flow rate range desired. A detailed description of the sprinkler system can be found in Tang *et al.*, 2006. As shown in **Fig. 4c**, by using the current regulator, flow disturbances were kept at a minimum. Water flow exited nozzle D, discharged above a hori-

zontal flat, and was contained by two sidewalls in the flow direction. The sidewalls began at nozzle D and continued to the plate cover, which was 0.3 m downstream of the nozzle exit. The two sidewalls contained the pressure transducer used to measure the static pressure distribution. The pressure transducer was connected via a data circuit to a computer. The uncertainty of the wall pressure distribution was calculated to be percent (Sourell *et al.*, 2003 and Tarjuelo *et al.*, 1999).

Mathematical Model

A finite limited volume was applied to simulate the inner flow characteristics of the complete fluidic sprinkler. The computational fluid dynamics method was applied to calculate the relationship between the flow rate and inner pressure, as well as the position of the reattachment region. The models were as follows (Yuan *et al.*, 2005):

Governing Equations

The turbulence model (Rodi, 1984 and Hossian and Rodi, 1986) is one of most widely used two-equation models in which is the turbulent kinetic energy and is the rate of turbulent energy dissipation. The eddy viscosity is calculated using:

$$\mu_t = \frac{\rho C_\mu k^2}{\varepsilon} \dots\dots\dots (1)$$

The values of μ_t and ε are calculated using transport equations that incorporate the effects of convection, diffusion, shear, and buoyancy in flows.

The governing equations include

the Reynolds mean flow equations (continuity and momentum) and the turbulent transport equations.

$$\frac{\partial \rho}{\partial t} + \frac{\partial(\rho u)}{\partial x} + \frac{\partial(\rho v)}{\partial y} + \frac{\partial(\rho w)}{\partial z} = 0 \dots\dots\dots (2)$$

$$\frac{\partial(\rho u)}{\partial t} + \frac{\partial(\rho u^2)}{\partial x} + \frac{\partial(\rho uv)}{\partial y} + \frac{\partial(\rho uw)}{\partial z} = -\frac{\partial p}{\partial x} + 2 \frac{\partial}{\partial x} \left(\mu_e \frac{\partial u}{\partial x} \right) + \frac{\partial}{\partial y} \left[\mu_e \left(\frac{\partial u}{\partial y} + \frac{\partial v}{\partial x} \right) \right] + \frac{\partial}{\partial z} \left[\mu_e \left(\frac{\partial u}{\partial z} + \frac{\partial w}{\partial x} \right) \right] \dots\dots\dots (3)$$

$$\frac{\partial(\rho v)}{\partial t} + \frac{\partial(\rho uv)}{\partial x} + \frac{\partial(\rho v^2)}{\partial y} + \frac{\partial(\rho vw)}{\partial z} = -\frac{\partial p}{\partial y} + 2 \frac{\partial}{\partial y} \left(\mu_e \frac{\partial v}{\partial y} \right) + \frac{\partial}{\partial x} \left[\mu_e \left(\frac{\partial u}{\partial y} + \frac{\partial v}{\partial x} \right) \right] + \frac{\partial}{\partial z} \left[\mu_e \left(\frac{\partial v}{\partial y} + \frac{\partial w}{\partial z} \right) \right] \dots\dots\dots (4)$$

$$\frac{\partial(\rho w)}{\partial t} + \frac{\partial(\rho uw)}{\partial x} + \frac{\partial(\rho vw)}{\partial y} + \frac{\partial(\rho w^2)}{\partial z} = -\frac{\partial p}{\partial z} + 2 \frac{\partial}{\partial z} \left(\mu_e \frac{\partial w}{\partial z} \right) + \frac{\partial}{\partial x} \left[\mu_e \left(\frac{\partial u}{\partial z} + \frac{\partial w}{\partial x} \right) \right] + \frac{\partial}{\partial y} \left[\mu_e \left(\frac{\partial v}{\partial z} + \frac{\partial w}{\partial y} \right) \right] \dots\dots\dots (5)$$

$$\frac{\partial(\rho k)}{\partial t} + \frac{\partial(\rho uk)}{\partial x} + \frac{\partial(\rho vk)}{\partial y} + \frac{\partial(\rho wk)}{\partial z} = \frac{\partial}{\partial z} \left[\left(\mu + \frac{\mu_t}{\sigma_k} \right) \frac{\partial k}{\partial z} \right] + \frac{\partial}{\partial y} \left[\left(\mu + \frac{\mu_t}{\sigma_k} \right) \frac{\partial k}{\partial y} \right] + \frac{\partial}{\partial x} \left[\left(\mu + \frac{\mu_t}{\sigma_k} \right) \frac{\partial k}{\partial x} \right] + P - \rho \varepsilon \dots\dots\dots (6)$$

$$\frac{\partial(\rho \varepsilon)}{\partial t} + \frac{\partial(\rho u \varepsilon)}{\partial x} + \frac{\partial(\rho v \varepsilon)}{\partial y} + \frac{\partial(\rho w \varepsilon)}{\partial z} = \frac{\partial}{\partial z} \left[\left(\mu + \frac{\mu_t}{\sigma_\varepsilon} \right) \frac{\partial \varepsilon}{\partial z} \right] + \frac{\partial}{\partial y} \left[\left(\mu + \frac{\mu_t}{\sigma_\varepsilon} \right) \frac{\partial \varepsilon}{\partial y} \right] + \frac{\partial}{\partial x} \left[\left(\mu + \frac{\mu_t}{\sigma_\varepsilon} \right) \frac{\partial \varepsilon}{\partial x} \right] + (C_1 P - C_2 \rho \varepsilon) \frac{\varepsilon}{k} \dots\dots\dots (7)$$

$$P = \left[2 \left(\frac{\partial w}{\partial z} \right)^2 + 2 \left(\frac{\partial v}{\partial y} \right)^2 + 2 \left(\frac{\partial u}{\partial x} \right)^2 + \left(\frac{\partial v}{\partial x} + \frac{\partial u}{\partial y} \right)^2 + \left(\frac{\partial w}{\partial x} + \frac{\partial u}{\partial z} \right)^2 + \left(\frac{\partial w}{\partial y} + \frac{\partial v}{\partial z} \right)^2 \right] \dots\dots\dots (8)$$

where x , y , and z are the horizontal, vertical, and height coordinates, respectively; t is time; u , v , and w are the velocities in the x , y , and z directions, respectively; ρ is density; p is pressure; P is production by shear; and C_1 , C_2 , C_μ , σ_ε , and σ_k

Fig. 4 Flow system



(a) Sprinkler irrigation system

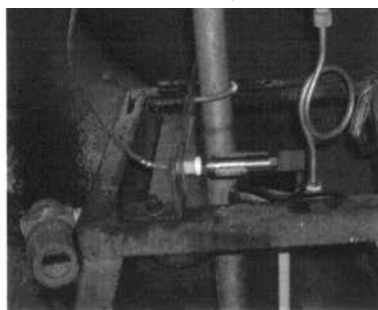

(b) Pressure transducer



(c) Wall-attaching offset jet in the sprinkler

are empirical constants, which take values of 1.44, 1.92, 0.09, 1.00, and 1.30, respectively, according to the recommendations made by Launder and Spalding (1974). The effective viscosity μ_e is defined as $\mu_e = \mu + \mu_t$, in which μ_e = turbulent viscosity and μ = molecular viscosity.

Boundary and Initial Conditions

Boundary conditions need to be specified on all surfaces of the computational domain. **Figs. 5a** and **b** depict the physical model of the 30PXH sprinkler. Boundaries presented in this study include inflow (faces AB and IJ), outflow (face EF), and solid walls (faces, BC, CH, DE, DG, FG, HI, and JA), as shown in **Fig. 5b**. At a solid surface, the no-slip condition is applied, that is, the velocities are zero. Standard wall functions were used at solid walls (Launder and Spalding, 1974).

The boundary conditions for the problem of a jet offset from a vertical solid wall in a homogeneous, calm water body between two horizontal solid boundaries are specified as

1. $u = v = w = 0$ on faces BC, CH, DE, DG, FG, HI, and JA;
2. $\partial k / \partial y = 0$ and $\varepsilon = (C_{\mu}^{3/4} k^{3/2}) / (0.4 \delta y)$ on faces BC, DE, FG, HI, and JA;
3. $\partial k / \partial x = 0$ and $\varepsilon = (C_{\mu}^{3/4} k^{3/2}) / (0.4 \delta x)$ on faces CH and DG;
4. $\partial u / \partial x = \partial v / \partial x = \partial w / \partial x = \partial k / \partial x = \partial \varepsilon / \partial x = 0$ and $\int_0^y u dy = Q_j (u \geq 0)$ on face FE;
5. $u = U_j, v = 0, k = f_1 p (1/2) U_j^2,$ and $\varepsilon = f_2 k^2$ on face AB.
6. $v = V_j, u = 0, k = f_1 p (1/2) V_j^2,$ and $\varepsilon = f_2 k^2$ on face IJ.

Furthermore, $U_j, V_j, Q_j,$ and B_0 are the jet velocity, air velocity, flow rate, and thickness at the discharge, respectively; y_1 is the total depth of the flow domain; δy and δx are the thicknesses of near-wall grids; f_1 and f_2 are empirical constants for the kinetic energy and the dissipation rate, respectively, resulting from inlet velocity fluctuations, i.e., a fraction of that calculated from the discharge velocity U_j .

The flow field is initially a quiescent fluid with zero initial flow velocity components u and v . The initial k and ε are set to be zero for stationary ambient water. An initially homogeneous density field is used throughout the basin. Flow parameters at the discharge ($U_j, V_j, Q_j,$ and B_0) do not vary with time.

Solution Method

The equations governing the flow field [(2)-(6)] were numerically solved using the method given by Patankar (1980) and Pankar (1981). A modified version of the computer program developed by Patankar (1982), based on the SIMPLER algorithm, was employed for the simulation. Variable time-steps were employed and determined by the speed of convergence in previous time-steps. The original computer code was extended to find solutions to unsteady, nonlinear flow problems and to incorporate the appropriate boundary conditions for an offset jet. The nonlinearities of the convection, diffusion, and source terms in the governing equations were handled by iteration within a time

step.

Numerical experiments and sensitivity analysis were carried out to eliminate the effects of the size of the computational domain and the number and distribution of grid points in the model. A non-uniform grid system was used with finer grids for the jet region and boundary layers and coarser grids for other regions. The size of the computational domain was characterized by a ratio of length to depth x_1 / y_1 . This relatively coarse grid system did not require a significant amount of computational time.

Results and Discussion

Pressure on the Two Sidewalls of the Main Jet Flow

The rotational principle of the complete fluidic sprinkler was based on the direction of the main jet flow according to the value of $P_L - P_R$. Therefore, it was important to find the value of $P_L - P_R$ for different working conditions. The wall inclination of the main flow jet is depicted in **Fig. 3b**. The curving streamline represented the main flow jet. The pressures in areas 1 and 2 were measured using a pressure transducer.

The complete fluidic sprinkler investigated in this study was the 30PXH model, and the specific details of 30PXH model can be found in reference (Zhu *et al.*, 2009). **Fig. 6** depicts the test results for $P_L - P_R$ for different operating pressures

Fig. 5 Physical model of the 30PXH sprinkler

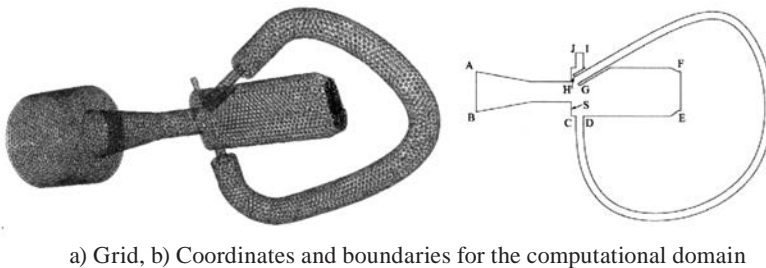
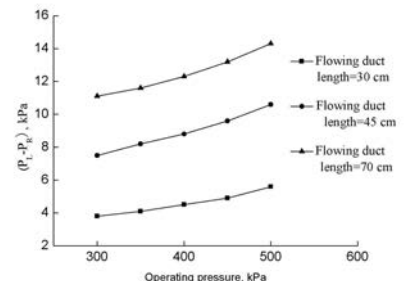

Fig. 6 $P_L - P_R$ for different operating pressures



and lengths of the flowing duct. As shown in **Fig. 6**, the longer the flowing duct, the larger P_L-P_R . P_L-P_R was much larger when the operating pressure was higher. When the flowing duct was much longer, significantly more time was required to remove all water from the flowing duct. Therefore, the jet absorbed more air from area 2, and the PR in low-pressure whirlpools became smaller. Air flowed into area 1 from the reverse blowdown nozzle at all times such that PL did not change. Thus, when the flowing duct was much longer, PL-PR became much larger. As the operating pressure increased, the velocity of the main jet flow increased. More air was taken out by the main jet flow, and the vacuum of the low-pressure whirlpools increased. PL did not change when PR was reduced; hence when the operating pressure was higher, PL-PR became much larger. It was determined that PL-PR depended only on the flowing duct length and operating pressure and had no de-

pendence on other factors.

Numerical Simulation

In the operation of the offset jet in a complete fluidic sprinkler, a slot jet is discharged into a limited space that is contained by two sidewalls. After leaving the nozzle, the jet curves towards the boundary and attaches to it, enclosing an eddying region of separated flow, as shown in **Fig. 1**. This phenomenon, known as the Coanda effect, is caused by a reduction in pressure on the inner side of the jet due to the entrainment of fluid by the jet.

According to the mathematical model mentioned above, numerical simulations were carried out in this study to identify offset jet parameters. As shown in **Fig. 5a**, the physical model was divided into a computational grid using the TGRID method. The meshing space of the modeled sprinkler was 0.5, and the number of grids was 151,328. **Fig. 7** depicts the numerically simulated velocity contour distributions rep-

resenting the flow fields at an initial jet velocity of 3 m/s. **Figs. 7a, b, and c** represent the velocity vectors of the straight main flow jet, the main flow jet reattached to the right side, and the main flow jet reattached to the left side, respectively.

When the main flow jet is reattached to the right side as shown in **Fig. 7b**, the numerical simulation results were as follows: **Fig. 8** depicts the wall-attaching pressure distribution of the 30PXH sprinkler. **Figs. 9a and b** are partially enlarged drawings of the pressure and velocity flow field distributions, respectively. **Fig. 10** is the section pressure distribution of the sprinkler. Face S, shown in **Fig. 2**, is the initial section. **Figs. 10a, b, and c** are the eddying section, middle section, and outflow section, which are 3 mm, 15 mm, and 30 mm away from the initial section, respectively. These figures demonstrate that the wall vacuum is much larger when the distance from the initial section is shorter. The pressure increases

Fig. 7 Velocity contour distributions of a 30PXH sprinkler

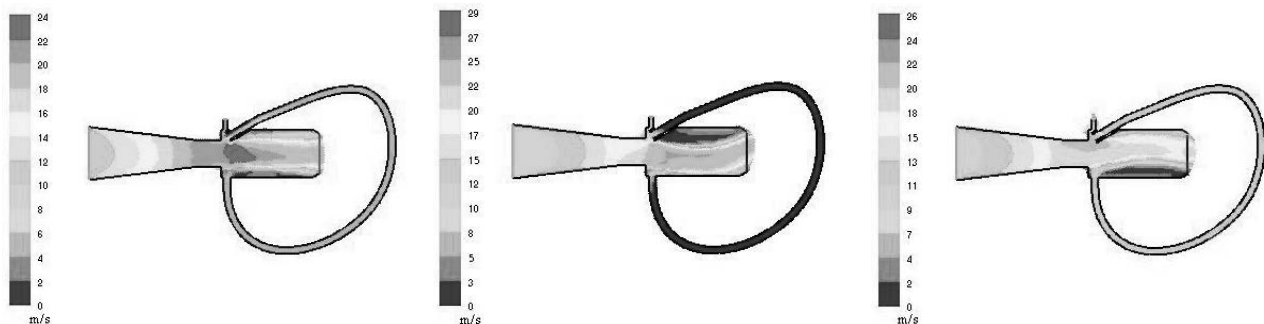

(a) Straight main flow jet. (b) Main flow jet reattached to the right side. (c) Main flow jet reattached to the left side.

Fig. 8 Wall-attaching pressure distribution of the 30PXH continuous flow sprinkler

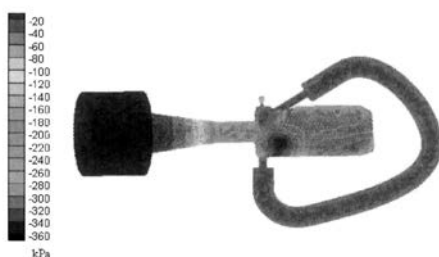
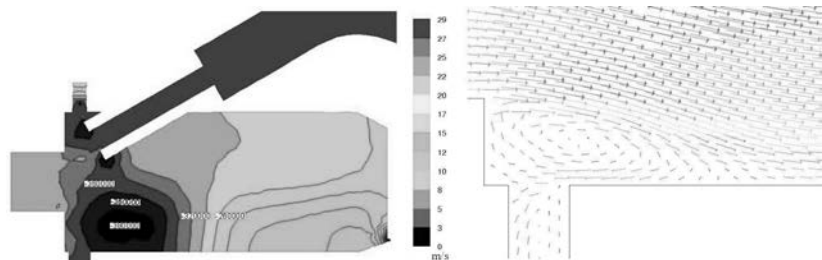

Fig. 9 Flow field distribution in the eddying area



a) Pressure, Pa b) Velocity

gradually along the direction of outflow. The vacuum is large in the eddying section because of the wall-attaching characteristics. The pressure difference between the two sidewalls of the main jet flow was identified using numerical simulation.

Comparison of the Numerical Simulation and Experimental Results

As shown in Fig. 3b, L represents the distance between the impingement point and the plate cover. The value of L was the same for different operating pressures for the same sprinkler. When the main flow jet reattached to the right side, area 1 was exposed to atmosphere and developed a pressure of about 100 kPa. The pressure in area 2 changed together with variations in the flow rate. The computational fluid dynamics method was applied to calculate the relationship between the flow rate and pressure in area 2, as well as the position of the reattachment region. The calculated results were compared to the experimental results.

Fig. 11 depicts the relationship between the flow rate (Q) and the vacuum in area 2 (H). H was positively influenced by Q. After regression of the data, a functional expression between H and Q was identified. A value of L for the sprinkler

was identified from numerical simulation and experimental results.

Table 1 compares the numerical simulation and experimental results, wherein the average deviation is defined as the average percent of difference between the values of the numerical simulation and the experimental results. The numerical simulation and experimental results depicted in Table 1 agrees well with one another, and the average deviation for simulated and experimental data was less than 5 percent. From the data depicted in table 1, it was concluded that the results of the numerical simulation could reflect the inner flow of a complete fluidic sprinkler.

Conclusions

In this manuscript, the proposed working principle of a complete fluidic sprinkler was described by studying the flow characteristics therein via a mathematical model. From a comparison between numerical simulation and experiments

conducted in the present study, the following conclusions were drawn:

1. The working principle of a complete fluidic sprinkler consisted of three statistical conditions: the straight primary flow jet, the main flow jet reattached to the right side, and the main flow jet reattached to the left side.
2. When the primary flow jet becomes reattached to the right side, the pressure in the two sidewalls of the main jet flow exclusively depends on flowing duct length and operating pressure.
3. Numerical simulation and the experimental results agree well with one another. The average deviation for our data was less than 5 percent.

It was concluded that the results obtained from the numerical simulation could reflect the inner flow of a complete fluidic sprinkler. The complete fluidic sprinkler was originally invented in China, and its flow characteristics continue to be poorly understood. Laboratory experiments along with more theoretical analyses and numerical modeling

Table 1 Comparison of numerical simulation and experimental results

Characteristics	Numerical simulation	Experiment	Average deviation
$H = f(Q)$	$H = 0.844 Q^{1.972}$	$H = 0.676 Q^{2.0567}$	4.6 %
L, mm	15.6	14.9	4.7 %

Fig. 10 Pressure distribution of the sprinkler

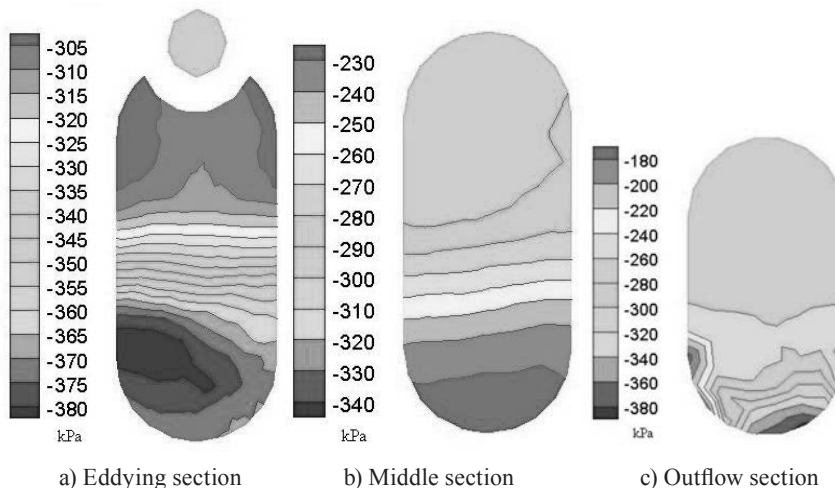
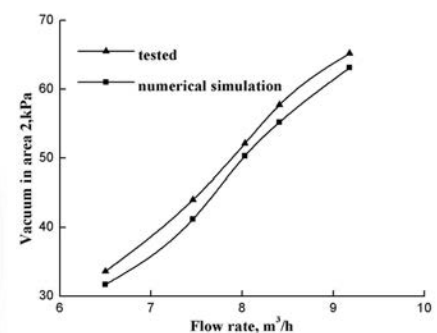

Fig. 11 Relationship between the flow rate and vacuum in area 2



are required for a more developed understanding of this type of sprinkler.

Acknowledgments

The authors are greatly indebted to the National Natural Science Foundation of China (No. 51109098), Program for National Hi-tech Research and Development of China (863 Program, No.2011AA100506), Program for China Postdoctoral Science Foundation (No. 20110491357), and Open Fund for Key Laboratory of Modern Agricultural Equipment and Technology, Ministry of Education & Jiangsu Province, Jiangsu University (No.NZ201008).

Nomenclature

The following symbols are used in this paper:

B_0 = thickness of the jet at the discharge origin
 C_1 = empirical constant
 C_2 = empirical constant
 C_μ = empirical constant
 f_1 = empirical constant
 f_2 = empirical constant
 g = acceleration of gravity, m/s²
 H = operating pressure
 L = distance between the impingement point and the plate cover
 P = production by shear
 p = pressure
 P_L = pressure in the left side of the main jet flow
 P_R = pressure in the right side of the main jet flow
 Q = flow rate
 Q_j = flow rate of the jet at the discharge origin
 u = velocity in the direction
 v = velocity in the direction
 w = velocity in the direction
 x = horizontal coordinate
 y = vertical coordinate
 z = height coordinate
 k = turbulent kinetic energy of fluctuation
 ϵ = rate of turbulent energy dissipation
 δx = thicknesses of the near-wall grid
 δy = thicknesses of the near-wall

grid
 μ = molecular viscosity
 μ_3 = effective viscosity
 μ_t = turbulent viscosity
 ρ = density
 σ_ϵ = empirical constant
 σ_k = empirical constant

REFERENCES

- Bourque, L. and B. G. Newman. 1960. Reattachment of a two-dimension incompressible jet to an adjacent flat plate. *Aeronautical Quarterly*, Vol.11: 201-232.
- Coanda, H. 1936. Device for deflecting a stream of elastic fluid projected into an elastic fluid. United States Patent Office, US2052869.
- Frederick, R. W. 2009. Seventy-fifth anniversary of horizontal action impact drive sprinkler. *Journal of Irrigation and Drainage Engineering* 135(2): 133.
- Hoch, J. and L. M. Jiji. 1981. Two-dimension turbulent offset jet-boundary interaction. *Trans. ASME* (103): 154-161.
- Hossain, M. S. and W. Rodi. 1986. A turbulent model for buoyant flows and its application to vertical buoyant jets, *Turbulent Buoyant Jets and Plumes*. W. Rodi, ed. Pergamon Press, Oxford, U.K.
- Nelson Irrigation Corp. 2002. 3000 series pivot products, (<http://www.nelsonirrigation.com/products>).
- J. R. Palfrey and J. A. Liburdy. 1986. Mean flow characteristics of a turbulent offset jet. *Trans. ASME*, 108: 82-88.
- Launder, B. E. and D. B. Spalding. 1974. The numerical computation of turbulent flow. *Comp. Methods Appl. Mech. Engrg.*, (3): 269.
- Patankar, S. V. 1980. *Numerical heat transfer and fluid flow*. Hemisphere Publishing Corporation, McGraw-Hill, New York, N.Y.
- Patankar, S. V. 1981. A calculation procedure for two-dimensional elliptic simulations. *Numerical Heat Transfer*, (4): 409-442
- Patankar, S. V. 1982. Computation of heat transfer and fluid flow-A general-purpose computer program for two-dimensional elliptic situations. Rep., Univ. of Minnesota, Minneapolis.
- Rodi, W. 1984. *Turbulent models and their application in hydraulics—a state of the art review*. Book Publ. of Int. Assoc. for hydr. Res., Delft, The Netherlands.
- Song, H. B., S. H. Yoon, and D. H. Lee. 2000. Flow and heat transfer characteristics of a two-dimensional oblique wall attaching offset jet. *International Journal of Heat and Mass Transfer*, (43): 2395-2404.
- Sourell, H., J. M. Faci, and E. Playan. 2003. Performance of rotating spray plate sprinklers in indoor experiments. *Journal of Irrigation and Drainage Engineering*, 129 (5): 376-380.
- Tang, Y., S. Q. Yuan, and H. Li. 2006. Auto-testing of sprinkler rainfall distribution based on distributional bus. *Transactions of the CSAE*, 22(4): 112-115. (in Chinese)
- Tarjuelo, J. M., J. Montero, and M. Valiente. 1999. Irrigation uniformity with medium size sprinkler. Part I: characteristic of water distribution in no-wind condition. *Transactions of ASAE*, 42(3): 665-675.
- Wang, Q. and Y. Lu. 1996. Theoretical laws for determining main parameters of wall-attached jet flow. *Journal of Jilin Agricultural University*, 18(1): 69-71,76. (in Chinese)
- Yuan, S. Q., X. Y. Zhu, H. Li, and Z. Y. Ren. 2005. Numerical simulation of inner flow for complete fluidic sprinkler using computational fluid dynamics. *Transactions of the CSAM*, 36(10): 46-49. (in Chinese)
- Yuan, S. Q., X. Y. Zhu, H. Li, and Z. Y. Ren. 2006. Effects of complete fluidic sprinkler on hydraulic characteristics based on some important geometrical parameters. *Transactions of the CSAE*, 22(10):

113-116. (in Chinese)
Zhu, X. Y. and S. Q. Yuan. 2008. Research and development of complete fluidic sprinkler. Proceedings of 2008 International Conference on Informationization, Automation and Electrifica-

tion in Agriculture, Zhenjiang, China, 308-311
Zhu, X. Y., S. Q. Yuan, and H. Li. 2009. Orthogonal test for the structure parameters of complete fluidic sprinkler. Transactions of the CSAE, 25(4): 103-107. (in Chi-

nese).
Zhu, X. Y., S. Q. Yuan, H. Li, and J. P. Liu. 2009. Irrigation uniformity with complete fluidic sprinkler in no wind conditions. Computer and Computing Technologies in Agriculture II, Vol. 2, 909-917.

■ ■

NEWS

◆ **ASABE Annual International Meeting**
July 29th to August 1st, 2012, Dallas Texas, USA
<http://www.asabemeetings.org/>

◆ **RAGUSA SHWA 2012**
—Safety Health Welfare in Agriculture Agro · Food and Forestry Systems—
September 3-6, 2012, Ragusa, CROATIA
<http://www.ragusashwa.it/2012/>

◆ **POTATO EUROPE 2012**
September 12-13, 2012, Villers-Saint-Christophe, FRANCE
<http://www.potatoeurope.com/165.html>

◆ **SAE 2012**
—Commercial Vehicle Engineering Congress—
October 2-3, 2012, Rosemont Illinois, USA
<http://www.sae.org/COMVEC>

◆ **AGROTECH Russia**
October 9-12, 2012, Moscow, RUSSIA
<http://www.agrotechrussia.com/>

◆ **IAMFE/China 2012**
—The 14th International Conference and Exhibition on Mechanization of Field Experiments—
October 12-14, 2012, Qingdao, CHINA
<http://www.iamfe2012.org>

◆ **Asian Forum of 2012**
—CSAM International Academic Annual Meeting "Innovation, Win-win, Development"—
October 27-30, 2012, Hangzhou, CHINA
<http://www.aaae.org.cn/DEB7A59D-08D7-47F1-BFF6-DA45754C5760.html>

◆ **EIMA International 2012**
November 7-11, 2012, Bologna, ITALY
<http://www.eima.it/it/index.php>

◆ **7th International CIGR Technical Symposium**
—Innovating the Food Value Chain—
November 25-28, 2012, South Africa
<http://www0.sun.ac.za/postharvest/cigr2012/>
Following the success of previous CIGR Section VI Posthar-

vest Symposia, 7th International CIGR Technical Symposium "Innovating the food value chain" will be held in the and historical 'Oak City' of Stellenbosch, South Africa. The Symposium will be held from 25th to 28th of November, 2012 in Stellenbosch University, South Africa. The Conference will highlight recent scientific advances and technological tools to handle, preserve, process, maintain and control quality and reduce losses in fresh and processed foods and agro-industrial raw materials, including fruit and vegetables, grains, roots and tuber, meat, seafood, herbs, spices, and cut flowers.

The Convenor of this symposium is Prof. Linus Opara, South African Research Chair in Postharvest Technology

Faculty of AgriSciences, University of Stellenbosch. He is also known as the co-editor of AMA, and has been contributing many essential papers from the past.

◆ **2012-International Conference**
—Challenges of Water & Environmental Management in Monsoon Asia—
November 27-29, 2012, THAILAND
<http://pawees.net/>

◆ **AG CONNECT Expo 2013**
January 29-31, 2013, Kansas City, Missouri, UA
<http://agconnect.com/>

◆ **International Conference on Agricultural Engineering in Oman**
—New Technologies for Sustainable Agricultural Production and Food Security—
February 24-26, 2013, Sultan Qaboos University, Oman
Dr. B. A. Stout of CIGR and Dr. Shujun Li of AAAE are invited as keynote speakers. Registration starts on November 30th, 2012.
<http://www.agengineeingconf.com>

◆ **2013 AMC Conference**
May 6-8, 2013, Waterloo, Iowa, USA
<http://www.amc-online.org/About.html>

◆ **XI International Controlled & Modified Atmosphere Reserch Conference**
June 3-7, 2013, Trani, ITALY
<http://www.ishs.org/news>

Co-operating Editors



B Kayombo



M F Fonteh



A A K
El Behery



S E
Abdallah



B S Pathak



R J Bani



I K Djokoto



D K Some



K Hourmy



J C Igbeka



L U Odigboh



Umar B. Bindir



K C Oni



L U Opara



N G
Kuyembah



A H
Abdoun



A B Saeed



A I Khatibu



E A Baryeh



S Tembo

-AFRICA-

Benedict Kayombo

Assoc. Prof. of Soil and Water Engg., Dept. of Agric. Engg. and Land Planning, Botswana College of Agric., Univ. of Botswana, Private Bag 0027, Gaborone, BOTSWANA. TEL+267-3650125, bkayombo@bca.bw

Mathias Fru Fonteh

Assoc. Prof. and Head, Dept. of Agril. Engg., Faculty of Agronomy and Agril. Sciences, Univ. of Dschang, P.O. Box 447, Dschang, West Region, CAMEROON. TEL+237-7774-0863, matfonteh@yahoo.com

Ahmed Abdel Khalek El Behery

Agric Engg. Research Institute, Agril. Reserch Center, Nadi El-Said St. P.O. Box 256, Dokki 12311, Giza, EGYPT. behery28@yahoo.com

Said Elshahat Abdallah

Assoc. Prof. Agril. Process Engg. & Postharvest Technology, Dept. of Agril. Engg., Faculty of Agric., Kafrelsheikh Univ., Kafr Elsheikh 33516, EGYPT. TEL+20-02-047-323-2762 (2115), dr.saidelshahat@yahoo.com

B. S. Pathak

Project Manager, Agric. Implements Research and Improvement Centre, Melkassa, ETHIOPIA

Richard Jinks Bani

Lecturer & Co-ordinator, Agric. Engg. Div., Faculty of Agric., Univ. of Ghana, Legon, GHANA

Israel Kofi Djokoto

Senior Lecturer, Univ. of Science and Technology, Kumasi, GHANA

David Kimutaiarap Some

Eng. Prof. Dept. of Agril & Biosystems Engg., School of Engg Chepkoilel University College of Moi Univ., P.O. Box: 2405-30100, Eldoret, KENYA, dkimutai-some2@gmail.com

Karim Houmy

Prof. and head of the Farm Mechanization Dept., Institute of Agronomy and Velerinary Medicine II, Secteur 13 Immeuble 2 Hay Riad, Rabat, MOROCCO. TEL+212-7-680512, houmy@maghrebnet.net.ma

Joseph Chukwugotium Igbeka

Prof., Dept. of Agril. Engg., Univ. of Ibadan., Ibadan, NIGERIA. TEL+234-2-810-1100-4, Library@ibadan.ac.ng

E. U. Odigboh

Prof., Agril. Engg Dept., Faculty of Engg., Univ. of Nigeria, Nsukka, Enugu state, NIGERIA. TEL+234-042-771676, MISUNN@aol.com

Kayode C. Oni

Department of Agricultural & Biosystems Engineering, Faculty of Engineering & Technology, University of Ilorin, PMB 1515, Ilorin, NIGERIA. TEL+234-803-5724708, kayoroll@gmail.com

Umar B. Bindir

Director General/CEO, National Office for Technology Acquisition and Promotion (NOTAP), No 4. Blantyre Street, Wuse II, PMB 5074, Abuja, FCT, Federal Republic of NIGERIA. TEL+234-946-11183, ubindir@yahoo.com

Linus U. Opara

Research Prof., S. Africa Chair in Postharvest Technology, Faculty of AgriSciences, Stellenbosch Univ., Private Bag X1, Stellenbosch 7602, SOUTH AFRICA. TEL+27-21-808-4604, opara@sun.ac.za

N. G. Kuyembah

Assoc. Prof., Njala Univ. Colle, Univ. of Sierra Leone, Private Mail Bag, Free Town, SIERRA LEONE. TEL+249-11-778620/780045

Abdien Hassan Abdoun

Member of Board, Amin Enterprises Ltd., P.O. Box 1333, Khartoum, SUDAN.

Amir Bakheit Saeed

Assoc. Prof., Dept. of Agric. Engg., Faculty of Agric., Univ. of Khartoum, 310131 Shambat, SUDAN. TEL+249-11-310131, absaeed5@yahoo.com

Abdisalam I. Khatibu

National Prolect Coordinafor and Direcror, FAO Irrigated Rice Production, Zanzibar, TANZANIA.

Edward A. Baryeh

Prof., Africa Univ., P.O.Box 1320, Mutare, ZIMBABWE.

Solomon Tembo

52 Goodrington Drive, PO Mabelreign, Sunridge,

Harare, ZIMBABWE.

-AMERICAS-

Hugo Alfredo Cetrangolo

Full Prof. and Director of Food and Agribusiness Program Agronomy College Buenos Aires Univ., Av. San Martin 4453, (1417) Capital Federal, ARGENTINA. TEL+54-11-4524-8041/93, cetrango@agro.uba.ar

Irenilza de Alencar Nääs

Prof., Agril. Engg. College, UNICAMP, Agril. Construction Dept., P.O. Box 6011, 13081 -Campinas-S.P., BRAZIL. TEL+55-19-788-1039, irenilza@agr.unicamp.br

A. E. Ghaly

Prof., Biological Engg. Deapartment Dalhousie Univ., P.O. Box 1000, Halifax, Nova Scotia, B3J2X4, CANADA. TEL+1-902-494-6014, abdel.gahaly@dal.ca

Alamgir Khan

Candidate Ph. D. Environmental Engg., School of Engg., Univ. of Guelph, 50-Stone Road East, Nig2w1 Guelph, Ontario, CANADA, alamgir@uoguelph.ca

Edmundo J. Hetz

Prof., Dept. of Agric. Eng. Univ. of Concepcion, Av. V.Mendez 595, P.O. Box 537, Chillan, CHILE. TEL+56-42-216333, ehetz@udec.cl

A. A. Valenzuela

Emeritus Prof., Ag. Eng. Fac., Univ. of Concepcion, Casilla 537 Chillan, CHILE. TEL+56-42-223613.

Roberto Aguirre

Assoc. Prof., National Univ. of Colombia, A.A. 237, Palmira, COLOMBIA. TEL+57-572-271-7000, FAX./4235, ra@palmira.unal.edu.co

Omar Ulloa-Torres

Prof., Escuela de Agricultura de la Region, Tropical Humeda (EARTH), Apdo. 4442- 1000, San Jose, COSTA RICA. TEL+506-255-2000, o-ulloa@ns.earth.ac.cr

S. G. Campos Magana

Leader of Agril. Engg. Dept. of the Gulf of Mexico Region of the National Institute of Forestry and Agril. Research, Apdo. Postal 429. Veracruz, Ver.



H A
Cetrangolo



I de A Nääs



A E Ghaly



Alamgir Khan



E J Hetz



A A
Valenzuela



R Aguirre



O Ulloa-Torres



S G C
Magana



H Ortiz-Laurel



W J
Chancellor



MR Goyal



A K
Mahapatra



G R Quick



S M Farouk



Daoulat
Hussain



M A Mazed



Chetem
Wangchen



Wang
Wanjun



S Illangantileke



S M Ilyas



Indra Mani



C R Mehta



A M Michael



T P Ojha



V M Salokhe



G Singh



S R Verma



Soedjatmiko



M Behroozil-
Lar

MEXICO.

Hipolito Ortiz-Laurel

Head of Agric. Engg. and Mechanization Dept./
Postgraduate College, Iturbide 73, Salinas de Hgo,
S.L.P., C.P. 78600, MEXICO. TEL+52-496-30448.

William J. Chancellor

Prof. Emeritus, Bio. and Agr. Eng. Dept., Univ. of
California, Davis, CA, 95616, U.S.A. TEL+1-530-753-
4292, wjchancellor@ucdavis.edu

Megh R. Goyal

Prof./Agric & Biomedical Engg., Univ. of Puerto
Rico, P.O.Box 0086, Rincon, PUERTO RICO, 00677-
0086, U.S.A., TEL+1-939-697-8039 goyalmegh@
gmail.com

Ajit K. Mahapatra

Present add: Agric. & Biosystems Eng. Dept., South
Dakota State Univ., P.O. Box 2120 Brookings, SD
57007-1496, U.S.A. TEL+1-605-688-5291, maha-
pata@sdsdstate.edu

-ASIA and OCEANIA-

Graeme R. Quick

Consulting Enginner, 83 Morrisons Road,
Peachester, Queensland, 4519, AUSTRALIA.
g.quick@bigpond.com

Shah M. Farouk

Prof. (Retd.), Farm Power & Machinery Dept., Ban-
gladesh Agril. Univ., Mymensingh 2200, BANGLA-
DESH. TEL+880-91-5695/2596, smf@bdcom.com

Daulat Hussain

Dean, Faculty of Agric. Engg. and Technology,
Bangladesh Agril. Univ., Mymensingh-2202, BAN-
GLADESH. TEL+880-91-52245

Mohammed A. Mazed

Member-Director, Bangladesh Agri. Res. Council,
Farmgate, Dhaka, BANGLADESH. mamazed@
barcbgd.org

Chetem Wangchen

Programme Director Agril. Machinery Centre
Ministry of Agric. Royal Government of Bhutan,
Bondey Paro Bhutan 1228, BHUTAN. krtamc@druk-
net.bt

Li Shujun

President, Chinese Academy of Agril. Mechaniza-
tion Sciences (CAAMS)/ Asian Association for Agril.
Eng. (AAAE), No.1 Beishatan Deshengmen Wai Bei-

jing 100083, CHINA. TEL+86-10-6488-2230, lisj@
caams.org.cn

Wang Wanjun

Past Vice Director and Chief Engineer/Chinese
Academy of Agril. Mechanization Sciences, 1
Beishatan, Beijing, 100083, CHINA. TEL+86-83-001-
6488-2710, wwj@isp.caams.org.cn

Sarath Illangantileke

Regional Representative for South and West Asia,
International Potato Center (CIP), Regional Office
for CIP-South & West Asia, IARI (Indian Agric. Res.
Institute) Campus, Pusa, New Delhe-12, 110002, IN-
DIA. TEL+91-11-5719601/5731481, cip-delhi@cgjar.
org

S. M. Ilyas

Project Director, DEC, National National Institute
of Rural Development (NIRD), Rajendranagar,
Hyderabad-500030, INDIA. Tel+91-40-2400-8417,
smiyas@city.com

Indra Mani

Senior Scientist, Division of Agril. Engineering IARI,
New Delhi-110012, INDIA. maniindra99@gmail.
com

C. R. Mehta

Head, Agricultural Mechanisation Division Central
Institute of Agricultural Engineering Nabi-bagh,
Berasia Road Bhopal - 462 038, India. TEL+91-755-
2747894, crmehta65@yahoo.co.in

A. M. Michael

1/64, Vattekunnam, Methanam Road, Edappally
North P.O., Cochin, 682024, Kerala State, S. INDIA.
kmichael65@eth.net

T. P. Ojha

Director General (Engg.) Retd., ICAR, 110, Vineet
Kung Akbarpur, Kolar Road, Bhopal, 462 023, INDIA.
TEL+91-755-290045

Vilas M. Salokhe

Prof., Vice Chancellor, c/o Lumino Industries 156
A & B, Rash Behari Avenue Kolkata-700029, INDIA.
vsalokhe@yahoo.com

Gajendra Singh

Former Vice Chancellor, Doon Univ. G-4, National
Agril. Science Centre (NASC) Complex Dev Prakash
Shastri Marg, Pusa Campus New Delhi-110052 IN-
DIA. TEL+91-99-71087591, prof.gsingh@gmail.com

S. R. Verma

Ex-Dean & Prof. of Agr. Engg., H. No. 14, Good
Friends Colony, Barewal Road, Ludhiana 141012.
Punjab, INDIA. TEL+91-161-2551096, srverma10@
yahoo.com

Soedjatmiko

President, MMAI (Indonesian Soc. of Agric. Eng. &
Agroindustry), Menara Kadin Indonesia Lt.29 Jl. HR.
Rasuna Said X-5/2-3 Jakarta, 12940, INDONESIA.
TEL+62-21-9168137/7560544.

Mansoor Behroozil-Lar

Prof., Behroozil Lar, Emeritus Tehran Uni. Agr. Engg.,
Ph.D., Jalal Ali Ahmad Nasim St. Nasim Danesh
Complex Block #35, second floor Tehran, IRAN.
Behroozil@yahoo.com

Saeid Minaei

Assistant Prof., Dept. of Agr. Machinery Eng., Tarbiat
Modarres Univ., P.O.Box 14115-111, Tehran, IRAN.
TEL+9821-602-6522-3 (office ext.2060, lab ext.2168)
minaee7@hotmail.com

Ali Mazin Abdul-Munaim

Assistant Prof., Dept. of Agril. Machines and Equip-
ments, College of Agric., Univ. of Baghdad, IRAQ.
TEL+964-778-4561, old2a3y@yahoo.com

Jun Sakai

Prof. Emeritus, Kyushu Univ., 2-31-1 Chihaya, Hi-
gashi-ku, Fukuoka city, 813, JAPAN. TEL+81-92-672-
2929, junsakai@mtj.biglobe.ne.jp

Bassam A. Snobar

Prof. and Vice President, Jordan Univ. of Science
and Technology, P.O.Box 3030 Irbid, 22110, JOR-
DAN. TEL+962-2-295-111, snobar@just.edu.jo

Chang Joo Chung

Emeritus Prof., Seoul National Univ., Agril. Engg.
Dept., College of Agric. and Life Sciences, Suwon,
441-744, KOREA. TEL+82-331-291-8131, chchung@
hanmail.net

Chul Choo Lee

Mailing Address: Rm. 514 Hyundate Goldentel Bld.
76-3 Kwang Jin Ku, Seoul, KOREA. TEL+82-2-446-
3473, cccslee@chollian.net

Muhamad Zohadie Bar daie

Prof., Dept. of Agril. and Biosystems Engg., Univ.
Putra Malaysia, 43400 upm, Serdang, Serdangor,
MALAYSIA. TEL+60-3-8946-6410, zohadie@eng.
upm.edu.my



Li Shujun



Saeid Mi-
naei



A. M. Abdul-
Munaim



J Sakai



BA Snorbar



CJ Chung



CC Lee



M Z
Bar daie



MP Pariyar



MA
Basunia



A D Chaudhry



A Q Mughal



R ur Rehmen



B T Devrajani



N A Abu-Khalaf



Surya Nath



R M Lantin



R P Venturina



S A Al-Suhaibani



A M S Al-Amri



S F Chang



T S Peng



S Krishnasreni



S Phong-supasamit



A Senanarong



Y Pinar



I Haffar



N Hay



P V Lang



A A Hazza'a

Madan P. Pariyar

Consultant, Rural Development through Selfhelp Promotion Lamjung Project, German Technical Cooperation. P.O. Box 1457, Kathmandu, NEPAL.

Mohammad Ali Basunia

Assistant Prof., Dept. of Soils, Water & Agril. Eng. (SWAE), CAMS, Sultan Qaboos Univ. (SQU), P.O. Box 34, Al-Khod, 123, Muscat, Sultanate, OMAN. Tel+968-2441-3668, basunia@squ.edu.om

Allah Ditta Chaudhry

Prof. and Dean Faculty of Agric. Engg. and Technology, Univ. of Agric., Faisalabad, PAKISTAN.

A. Q. A. Mughal

Vice Chancellor, Sindh Agr. Univ., Tandojam, PAKISTAN.

Rafiq ur Rehman

Director, Agril. Mechanization Reserch Institute, P.O. Box No. 416 Multan, PAKISTAN

Bherulal T. Devrajani

Prof. and Chairman, Faculty of Agril. Engg., Sindh Agric. Univ., Tandojam, Sindh, PAKISTAN. TEL+92-2233-5594

Nawaf A. Abu-Khalaf

Engineer, the Project Directorate in Palestinian Agril. Ministry, P.O.Box 405, Hebron, PALESTINE. TEL+972-2-2227-846/7, nawafu@hotmail.com

Surya Nath

Princiipal Scientist, National Agril. Research Institute, Momase Regional Centre-Bubia, P.O.Box 1639 Lae, Morobe Province PAPUA NEW GUINEA. TEL+675-475-1033, drnath.surya@gmail.com

Reynaldo M. Lantin

Prof., College of Engg. and Agro-Industrial Technology Univ. of the Philippines Los Banos, Laguna 4031, PHILIPPINES. TEL+63-49-536-2792, rmlantin@mudspring.uplb.edu.ph

Ricardo P. Venturina

President & General Manager, Rivelisa publishing House, 215 F, Angeles St. cor Taft Ave. Ext., 1300 Pasay City, Metro Manila, PHILIPPINES.

Saleh Abdulrahman Al-suhaibani

Prof., Agril. Engg. Dept., College of Agric., King Saud Univ., P.O. Box 2460 Riyadh 11451, SAUDI ARABIA. salsuhaibani@gmail.com

Ali Mufarreh Saleh Al-Amri

Prof., Dept. of Agric. Engg., Colleg of Agril. and Food Sciences, King Faisal Univ., Al-Ahsa, SAUDI ARABIA. aamri@kfu.edu.sa

Sen-Fuh Chang

Prof., Agric.-Machinery Dept. National Taiwan Univ., Taipei, TAIWAN. sfchang@ntu.edu.tw.

Tieng-song Peng

Deputy Director, Taiwan Agril. Mechanization Research and Development Center. FL. 9-6, No. 391 Sinyi Road, Sec. 4, TAIWAN.

Suraweth Krishnasreni

1178/268 Soi Senanikom 1 Road Paholyothin 32 Chankasem, Chatuckack, Bangkok 10900, THAILAND.

Surin Phongsupasamit

President, Institute for Promotion of Teaching Science and Technology, 924 Sukumit Rd. Klong Toey Bangkok, THAILAND.

Akkapol Senanarong

Director, Agril. Engg. Research Institute, Dept. of Agric., Bangkok, 10900, THAILAND. akkapol@ksc.th.com

Yunus Pinar

Prof. and Head, Trakya Univ., College of Technical Sciences, Dept. of Machine Sarayici Campus, Edirne, TURKEY. ypinar@trakya.edu.tr

Imad Haffar

Managing Director, Palm Water Jumeirah Village (Site Office Gate #10) Al Khail Road, P.O. Box 215122, Dubai, UAE. Tel+971-4-375-1196, imad.haffar@palmwater.ae

Nguyen Hay

Assoc. Prof., Dean of Faculty of Engg., Nonglam Univ., Linh Trung Ward, Thu Duc District, Ho Chi Minh City, VIET NAM. nguyenhay@hcm.fpt.vn

Pham Van Lang

Director, Vietnam Institute of Agril. Engg., A2-Phuong Mai, Dong Da Hanoi, VIET NAM.

Abdulsamad Abdulmalik Hazza'a

Prof. and Head of Agril. Engg. Dept., Faculty of Agric., Sana'a Univ., P.O.Box 12355, Sana'a, YEMEN. TEL+967-1-407300, hazaia@yahoo.com

-EUROPE-

Anastas Petrov Kaloyanov

Prof. & Head, Research Laboratory of Farm Mechanization, Higher Institute of Economics, Sofia, BULGARIA.

Pavel Kic

Vice-Dean/Technical Faculty, Czech Univ. of Agric. Prague, 16521 Prague 6-Suchdol, CZECH. TEL+420-2-2438314 KIC@TFCZU.CZ

Joachim Müller

Prof. of the Univ. Hohenheim, Institute of Agril. Engg., Head of Agric.I Engg. in the Tropics and Subtropics, Univ. of Hohenheim, 70593 Stuttgart, GERMANY. TEL+49-711-459-22490, joachim.muller@uni-hohenheim.de

Giuseppe Pellizzi

Director of the Institute of Agric. Eng. of the Univ. of Milano and Prof. of Agric. Machinery and Mechanization, Via G. Celoria, 2-20133 Milano, ITALY. TEL+39-2-503-16871, giuseppe.pellizzi@Unimi.it

W. B. Hoogmoed

Univ. Lecturer, Faculty of Lsg Agrarische Bedrijfstechologie, Wageningen Univ., Agrotechnologie en Voedingswetenschappen, Bornsesteeg 59, 6700 AA, Wageningen, P.O.Box 17, NETHERLAND. willem.hoogmoed@wur.nl

Jan Pawlak

Prof., head of the Dept. of Economics and Utilization of Farm Machines at IBMER, Prof. at the Univ. of Warmia and Mazury in Olsztyn, Fac. of Tech. Sci, POLAND. j.pawlak@itep.edu.pl

Oleg S. Marchenko

Prof. and Agril. Engineer, Dept. Head in All-Russia Research Institute for Mechanization in Agric. (VIM), 1st Institut'sky proezd, 5, Moscow 109428, RUSSIA. TEL+7-95-174-8700, oleg072000@mail.ru

John Kilgour

Senior Lecturer in Farm Machinery Design at Silsoe College, Silsoe Campus, Silsoe, Bedford, MK45 4DT, UK.

Milan Martinov

Prof., Faculty of Technical Sciences, Chair for Biosystems Engg., Novi Sad, SERBIA. TEL+ 381-21-485-2369, MilanMartinov@uns.ac.rs



A P Kaloyanov



P Kic



J Müller



G Pellizzi



W B Hoogmoed



Jan Pawlak



O S Marchenko



J Kilgour



M Martinov

Retired Co-editors' Name List

Co-editor's name	Nationality	Inaugural year	Retired year	Co-editor's name	Nationality	Inaugural year	Retired year
Adrian Moens	Netherlands	1972	1989	Paris Andereou	Lebanon	1980	1984
Bala Krishna Shrestha	Nepal	1972	1991	Allan L. Phillips	U. S. A.	1981	2004
Chau Van Khe	Vietnam	1972	1980	Julien G. Van Lancker	Brundi	1981	1989
Manbahadur Gurung	Bhutan	1972	2006	Suppiah Kathirkamathamby	Sri Lanka	1981	1991
Merle L. Esmay	U. S. A.	1972	1990	Armed Hossain Mirdha	Mexico	1982	1991
Md. Shahansha-Uddin Choudhury	Bangladesh	1973	1991	David Boakye Ampratwum	Ghana	1982	2011
Mohamed A. Bedri	Sudan	1973	1987	Kshirode Chandra Roy	Bangladesh	1982	1985
T. B. Muckle	U. K.	1973	1978	M. H. Abdel Aziz	Saudi Arabia	1982	1991
T. Touggaard Pedersen	Denmark	1975	1990	Krishna Prakash Srivastava	Ethiopia	1983	1989
Bilash Kanti Bala	Bangladesh	1976	1982	Muhammad Siddique Chaudhry	U.S.A.	1983	1991
George B. Hanna	Egypt	1976	1988	Wimala Tissa Weerakoon	Zambia	1983	1985
Siswadi Soepardjo	Indonesia	1976	1985	Harry D. Henderson	Lebanon	1984	1985
Mohammad Ilyas	Pakistan	1977	1981	Mohammad Afzal	Pakistan	1984	1994
Amala Prasad Sharma	Fiji	1978	1981	Aalbert Anne Wanders	Netherlands	1988	2007
Arumugam Kandiah	Ethiopia	1978	1989	Ali Mahmoud El Hossary	Egypt	1988	2010
Satish Chandra	Fiji	1979	1990	Chanchai Rojanasaroj	Thailand	1988	2011
Jitendra P. Mittal	Nigeria	1980	1993	Eltag S. Eldin Mahmoud	Sudan	1990	2011
Naresh Chandra Saxena	India	1980	1988	Henrik Have	Denmark	1990	2009

TWO-WHEEL TRACTOR ENGINEERING for Asian Wet Land Farming

by Jun Sakai

Professor emeritus of Kyushu University, Co-operating Editors of AMA



A Present to the students who dream to be an international-minded specialist in farm machinery science & technology.

Introduction of new "Tractor-Tillage Engineering" based on a global view of agricultural civilizations in the world.

Two-wheel tractors contribute to the industrial promotion of agri-countries consisting of small-scale family farms.

The textbook with new guidelines for international technical cooperation with a better mutual understanding.

CONTENTS

1. Difference between Euro-American and Asian farming civilizations
2. New wheel dynamics and tractor-vehicle engineering in the 21th century
3. New plowing science of walk-behind tractors originated from Asian paddy farming
4. Scientific creation and systematization of rotary tillage engineering in Asia

English - Japanese Version

Price: Japanese

Size: 21cm x 15cm, soft cover, 311 page

Shin-Norinsha Co., Ltd.

1-12-3 Kanda Nishikicho, Chiyoda-ku, Tokyo, Japan, Tel: +81-(0)3-3291-3671~4, Fax: +81-(0)3-3291-5717

E-mail: ama@shin-norin.co.jp URL: http://www.shin-norin.co.jp

Vol.41, No.4, Autumn, 2010

Effect of Different Machinery on Rice Crop Establishment and their Influence on Subsequent Wheat Crop in India (V. P. Chaudhary, K. S. Gangwar).....	9
Status of Post Harvest Technology of Agricultural Crops in Sri Lanka (T. M. R. Dis-sanayake, N. K. Jain).....	17
Evaluation of Cotton Processing Loss in Modernized Indian Roller Gins (V. G. Arude, S. K. Shukla, T. S. Manojkumar, D. N. Makawan).....	24
Design, Development, Testing and Comparative Evaluation of the Betel Leaf Oil Extractor (P. Guha).....	28
Spray Droplet Number and Volume Distribution as Affected by Pressure and Forward Speed (Mohamed Hassan Dahab, Nuha Bushra Eltahir).....	36
Effect of Soil Compaction on Growth of Corn (Zea Mays L) and Mungbean (Vigna Radiata (L) Wilczek) (F. Vidinamo, L. Anota, S. Nath).....	43
Development and Field Evaluation of Tractor-mounted Air-assisted Sprayer for Cotton (Shashi Kumar Singh, Surendra Singh, Anoop K Dixit).....	49
Rohinish Khurana Vibration Evaluation of Ginning and Pressing Machinery in Indian Cotton Ginneries (V. G. Arude, S. K. Shukla, T. S. Manojkumar).....	55
Technical Evaluation of the Agricultural Tractor Park of Chile (Edmundo J. Hetz, Denisse A. Slater, Marco A. López).....	60
Field Performance Evaluation of Manual Operated Petrol Engine Powered Weeder for the Tropics (S. O. Nkakini, A. J. Akor, M. J. Ayotamuno, A. Ikoromari).....	68
E. O. Efenudu Stage Number Effect on Vertical Line Shaft Deep Well Irrigation Pumps (Sinan Toprak, Sedat Çalışır).....	74
Effect of Pure Biodiesel on Fuel Injection Systems and Noise Level in Agricultural Diesel Engines (Yilmaz Bayhan, Erdal Kiliç, Selçuk Arin).....	78
Economic Evaluation of Investment in Animal Traction a Case Study of Katsina State, Nigeria (Abdu Babangida Umar).....	82
Thermal Efficiency Enhancement of a Solar Drier for Hay Making from Sugar Beet Tops (Said Elshahat Abdallah).....	87



Vol.42, No.1, Winter 2011

Development and Evaluation of Tractor Operated Sub Soil Coir Pith Applicator (K. Kathirvel, D. Manohar Jesudas, B. Anuraja).....	7
Decision Modeling for Mechanization Strategies of Rice Cultivation in Chhattisgarh, India (Ajay Kumar Verma).....	14
Effects of Different Cleaning Systems and Storage Duration on the Internal and External Quality of Sugar Beets (Koç Mehmet Tuğrul, Ayhan Kangal, Ahmet Çolak).....	21

Design and Development of an Experimental Cotton Picking Aid: Part I (Ankit Sharma, S. S. Ahuja V. P. Sethi, Derminder Singh)..	29
Noni—a Hope in a Bottle (Syed Zameer Hussain, A. R. Malik, M. R. Dalal, B. N. Dar, S. M. Wani).....	35
Studies on Standardisation of Spacing and Trans-planting Depth for a Self Propelled Rice Transplanter (V. M. Duraisamy, T. Senthilkumar, S. Subbulakshmi).....	42
Musculoskeletal Discomfort and its Reduction in Cotton Cultivation (Veena Sangwan, Sudesh Gandhi Supriya Mer).....	45
Animal Powered Transmission System: An Alternative Energy Source for Small Agro Processing Machines (G. S. Tiwari, Rajeev Garg, M. S. Sevda, V. D. Mudgal, Lokesh Gupta).....	49
Present Status and Future Strategies for Popularizing Greenhouses in Kashmir and Ladakh Region of J & K State (INDIA) (Navin C. Shahi, M. Feza Ahamad, Anil Kumar, Umesh C. Lohani).....	54
Effect of Kinematic Parameter on some Performance Indices for the Self-Propelled Compost Turning Machine (T. Z. Fouda).....	61
<i>The Farm Machinery Industry in Japan and Research Activities</i>	
The Present State of Farm Machinery Industry (Shin-Norinsha Co., Ltd).....	66
Japanese Agriculture and Agricultural Machinery—Current Status and Problems (Osamu Yukumoto).....	72
The Organization and Activities of JAICABE (Takemi Machida).....	76
New Stage of Agricultural Mechanization Research in Japan (Sakae Shibusawa).....	79
Robot Farming System in Japan (N. Noguchi, O. C. Barawid Jr).....	83
Investigation of Nonlinear Vibration Characteristics of Agricultural Rubber Crawler Vehicles (Eiji Inoue, Muneshi Mitsuoka Ma Rabbani).....	89
Main Production of Agricultural Machinery Manufactures in Japan.....	94
Directory.....	98



Vol.42, No.2, Spring 2011

Effect of Selected Tillage Implements on Physical Properties of Two Types of Soils in Khartoum Area (Sudan) (Mohamed Hassan Dahab, Safia Abdel Moneim Elzain).....	9
Comparative Field Evaluation of Self-Propelled Paddy Transplanter with Hand Transplanting in Valley Lands of Kashmir Region (Jagvir Dixit, J. N. Khan).....	14
Evaluation of Agricultural Mechanization Level in Agricultural Production Areas (Pham Van Lang, Bui Quang Huy, Do Thi Tam, Pham Hong Son).....	19
The Cost of Fluidized-Bed Drying Using a Buffered Salt Layer (Nguyen Hay, Le Quang Giang, Vu Ke Hoach).....	24

Development and Evaluation of Tractor Operated Rotary Spading Machine (K. Kathirvel, D. Manohar Jesudas, D. Selvakumar).....	28
Transplanting Machine Operation Analysis (A. Natsis, S. Fountas, T. Gemtos).....	33
The Effect of some Components on Performance of Flat Plate Solar Water Collectors (Turhan Koyuncu, Yunus Pinar, Fuat Lüle).....	37
Effect of Various Air Drying Temperatures on Quality of Dehydrated Garlic Slices (Allium Sativum. L.) (A. Rouf, Syed Zameer Hussain, J. Kabir).....	45
Design, Development and Performance Evaluation of Radial Arm Type Cashew Nut Sheller (D. Balsubramanian).....	49
Design and Development of a Weeder for both Lowland and Upland Conditions (M. A. Hossen, M. S. Islam, M. D. Huda, M. A. Zami, M. G. K. Bhuyan, B. C. Nath).....	56
Development and Laboratory Performance of an Electronically Controlled Metering Mechanism for Okra Seed (T. P. Singh, D. M. Mane).....	63
Anthropometric Dimensions of Turkish Operators of Loading Tractors Used in Forestry and the Design of the Workplace (Kenan Melemez, Metin Tunay).....	70
Performance of 3.75 kW Diesel Engine Using Different Blends of Jatropha Oil (Rajiv Varshney, C. R. Mehta, Anil K. Dubey, B. R. Nayak).....	79
Engineering Studies on the Performance of Paddy and Rice Separator (T. Z. Fouda).....	85



Vol.42, No.3, Summer 2011

Effect of Blade and Operational Parameters on Shredding Efficiency of an Experimental Cotton Stalk Shredder (T. Senthilkumar, R. Manian, K. Kathirvel).....	9
Field Evaluation of the Developed Experimental Cotton Picking Aid: Part II (Ankit Sharma, S. S. Ahuja, V. P. Sethi).....	14
Status of Maize Threshing in India (S. P. Singh, Pratap Singh, Surendra Singh).....	21
A Mechanical Flame Unit for Soil Pest Control (M. M. Ibrahim, H. El. Abd Alla, R. G. Salim).....	29
Agitator Unit in Auger Metering Device for Fertilizer Applicator (Z. E. Ismaila, M. M. Ibrahim, M. A. El-Saadanya, O. A. Foudab).....	36
Off Season Cultivation and Techno-Economic Evaluation of Okra Grown under Greenhouse (J. N. Mishra, P. L. Pradhan, J. C. Paul).....	42
Post-Harvest Technology of Betel Leaf (Piper Betle L.): Effect of Curing on Quality and Physiological Parameters (S. Sadhukhan, P. Guha).....	47
Moisture Content Effect on Sewage Sludge for Land Farming Application (C. P. Uk-paka, J. Odharo).....	52
Development and Evaluation of Betel Leaf Conditioning Chamber (K. Rayaguru, U.	

S. Pal, Md. K. Khan)	61
Soaked and Non-Soaked Drying Methods for Vanilla (<i>Vanilla Planifolia</i> L.) (Gürkan A. K. Gürdil, David Herák, Jindřich Karan- ský, Bahadır Demirel, Satya Simanjuntak)66	
Quantifying Farm Women Involvement in Different Paddy Cultivation Practices in Tamil Nadu (R. S. Singh, L. P. Gite, K. V. R. Rao)	71
Solar Energy Utilisation for Providing and Maintaining Optimal Microclimatic Con- ditions of Greenhouse Cucumber (Salah, M. Abdellatif, Ahmed H. Silim).....	76
The Reaper as an Alternative System for Lit- ter Removal Inside Broiler Houses (M. A. Basiouny, Said Elshahat Abdallah)	85



Vol.42, No.4, Autumn 2011

Farm Mechanization in Bhutan (Karma Thin- ley, Chetem Wangchen, Hai SAKURAI) ...	9
Mechanization and Economic Analysis of Wheat Production in Iran (Narges Banae- ian, Morteza Zangeneh)	15
Effect of Crop, Machine and Operational Parameters on Peak Cutting Force for Harvesting Fodder Maize (K. Kathirvel, B. Suthakar, D. Manohar Jesudas)	28
Algorithmic Approach for Overhauling of- Modern Bulldozers thorough Management Techniques (PERT/CPM) (M. Muthamil Selvan, C. Divaker Durairaj, K. Ran- gasamy, R. Hemalatha)	33
Design of a Grain Cleaning Machine for Small Farms (K. D. Astanakulov, Yo. Z. Karimov, G. Fozilov).....	37
Internal Air Flow Characteristics of a Head- feed Combine-1 —Analysis of the Air Velocity in the Grain Separation Tunnel— (Choung-Keun Lee).....	41
Internal Air Flow Characteristic of a Head- feed Combine-2 —Analysis of the Air Di- rection in the Grain Separation Tunnel— (Choung-Keun Lee).....	48
Greenhouse Glazing Material Effect on Evaporative Cooling for Tomato Pro- duction under Summer Conditions (Salah M. Abdellatif, Hosam A. Hawas).....	54
Development of a Hydraulic Trainer Bench for Educational Purposes (O. A. Rahama, A. F. Kheiralla, H. Y. Abdelrahman, M. Dina, A. Adam, M. Ghada).....	62
Development and Evaluation of a Power Tiller Operated Planter for Maize (P. L. Pradhan, J. N. Mishra, J. C. Paul, S. K. Nanda)	67
Impact of Arable Land Management and Tillage on Soil Water and Solute Balance in the Sub-Humid Climate of North-East Germany (U. Schindler, L. Müller).....	72
Evaluation of some Soil Quality Indices under Two Soil Tillage Systems in a Tropical Re- gion of South East Mexico (S. G. Campos- Magaña, M. Cadena-Zapata)	77
Effect of Manner of Stacking on Changes in Nutritional Value of Treated Baled Paddy Straw by Dripping Technique (J. P. Singh, T. C. Thakur, Sushil Sharma, R. K. Srivas- tava).....	84
Pneumatic Wheeled Multipurpose Tool Frame for Efficient Utilization of Draught Animal Power (G. S. Tiwar, Rajeev Garg,	

M. S. Sevda, Lokesh Gupta)	88
----------------------------------	----



Vol.43, No.1, Winter 2012

Utilization Pattern of Tractors in Nalanda District of Bihar- A Case Study (V. B. Shambhu, S. K. Chaudhary)	9
Design and Development of a Single Screw Fish Pellet Extruder (Theresa K. Philip, J. O. Okoro).....	14
Effectiveness of the Aeration Method and Pile Shape during Composting Process (Said Elshahat Abdallah, M. A. Basiouny, G. H. Ghanem).....	18
Economical Moisture Measurement System for Dried Longan Aril Using Electrical Capacitance (Sanong Amaroek, Nipon Theera-Umpon)	29
In Situ Hyperspectral Measurements and High Resolution Satellite Imagery to De- tect Stress in Wheat in Egypt (A. H. Elmet- walli, A. A. Derbala, T. Z. Fouda).....	34
Development and Evaluation of Worker Friendly Arecanut Stripper (K. Kathirvel, D. Ramesh, D. Manohar Jesudas).....	39
Farm Layout and Planting System for Sweet- potato Production in Malaysia (Md. Akhir Hamid, Desa Ahmad, Ibni Hajar Rukun- nuddin)	44
Performance Evaluation of Combine Har- vester and the P.T.O. Tractor Operated Thresher for Stationary Threshing of Sorghum (Lotfie A. Yousif, Sheikh El Din Abdel Gadir El-Awad)	52
Aerial Spraying with Viscosity Modifer (Samir M. Younis)	57
Air Assisted Sleeve Boom Sprayer (Muham- mad Yasin)	61
Performance Evaluation of Ncam-Modified Kerosene-Fired Batch Dryer (K. C. Oni, A. T. Ajiboye, O. A. Oyelade).....	67
Manual and Motor Operated Paddy Thresher for the Kashmir Valley (Navin C. Shahi, Junaid N. Khan, Umesh C Lohani, Anu- pama Singh)	74
Development of Electronic Weight Grader for Sapota (Syed Mazara Ali, S. C. Mandhar)..	78
<i>The Farm Machinery Industry in Japan and Research Activities</i>	
Main Production of Agricultural Machinery Manufactures in Japan	82



Vol.43, No.2, Spring, 2012

A Two Row Subsoil Organic Mulch Cum Fertilizer Applicator (K. Kathirvel, R. Thi- yagarajan, D. Manohar Jesudas).....	9
Temperature and Airflow Rate Effect on Ar- tificial Ripening Process of Banana (Said Elshahat Abdallah, M. A. Basiouny).....	15
Potential of Micro-Hydropower Generation Systems in India (M. Muthamil Selvan, C. R. Mehta, A. C. Varshney).....	25
Multi-Purpose Solar Tunnel Dryer for a Mixed Farming System (R. G. Manjarekar, A. G. Mohod, Y. P. Khandetod).....	32
Energy Consumption Pattern in Production of Paddy Crop in Haryana State in India (Indra Mani, S. K. Patel).....	39
Compatibility of Jatropa Oil Bio-Diesel and	

Petro Diesel as an Engine Fuel Based on their Characteristic Fuel Properties (V. B. Shambhu, T. K. Bhattacharya, S. K. Chaudhary).....	43
Development and Evaluation of Mechanical Picking Heads for Citrus Fruits Harvesting (Soliman, A. H., M. E. El-Iraqi, Y. Sharo- beem, T. R. Awais)	50
Introduction of Improved Equipment and Hand Tools for Farm Mechanization of Hilly Region in Indian Himalayas (K. P. Singh, C. B. Khoragade, A. K. Srivastva) ..	59
Mechanization Practices in Rice-Wheat Cro- ping Systems in Upper Gangetic Plains of India (K. S. Gangwar, V. P. Chaudhary, D. K. Pandey, B. Gangwar, K. K. Singh).....	66
Evaporative Cooling Chambers using Alter- native Materials (Yogender Singh, Y. K. Yadav)	75
Design, Development and Performance Eval- uation of Plantain Slicer (N. Kalaivani, K. Thangavel, R. Viswanathan).....	79
Economics of Basin-lister cum Seeder for In- situ Moist-ture Conservation in Drylands of Indian Cotton Fields (M. Muthamil Selvan, R. Manian, K. Kathirvel, K. Rangasamy) ..	84



INSTRUCTIONS TO AMA CONTRIBUTORS

The Editorial Staff of the AMA requests of articles for publication to observe the following editorial policy and guidelines in order to improve communication and to facilitate the editorial process:

Criteria for Article Selection

Priority in the selection of article for publication is given to those that –

- a. are written in the English language;
- b. are relevant: to the promotion of agricultural mechanization, particularly for the developing countries;
- c. have not been previously published elsewhere, or, if previously published are supported by a copyright permission;
- d. deal with practical and adoptable innovations by, small farmers with a minimum of complicated formulas, theories and schematic diagrams;
- e. have a 50 to 100-word abstract, preferably preceding the main body of the article;
- f. are printed, double-spaced, under 3,000 words (approximately equivalent to 6 pages of AMA-size paper) ; and those that
- g. art: supported by authentic sources, reference or bibliography.
- h. written on CD-R.

Rejected/Accepted Articles

- a. As a rule, articles that are not chosen for AMA publication are not returned unless the writer(s) asks for their return and are covered with adequate postage stamps. At the earliest time possible, the writer(s) is advised whether the article is rejected or accepted.
- b. When an article is accepted but requires revision/modification, the details will be indicated in the return reply from the AMA Chief Editor in which case such revision/modification must be completed and returned to AMA within three months from the date of receipt from the Editorial Staff.
- c. The AMA does not pay for articles published.
- d. Complimentary copies: Following the publishing, three successive issue are sent to the author(s).

Procedure

- a. Articles for publication (original and one-copy) must be sent to AMA through the Co-operating Editor in the country where the article originates. (Please refer to the names and addresses of Co-operating Editors in any issue of the AMA). However, in the absence of any Co-operating Editor, the article may be sent directly to the AMA Chief Editor in Tokyo.
- b. Contributors of articles for the AMA for the first time are required to attach a passport size ID photograph (black and white print preferred) to the article. The same applies to those who have contributed articles three years earlier. In either case, ID photographs taken within the last 6 months are preferred.
- c. The article must bear the writer(s) name, title/designation, office/organization, nationality and complete mailing address.

Format/Style Guidance

- a. Article must be sent on CD-R with MS DOS format (e.g. Word Perfect, Word for DOS, Word for Windows... **Absolutely necessary TEXT FORMAT**) along with two printed copy (A4).
- b. The data for graphs and photographs must be saved into piecemeal dates and enclosed with the article.
- c. Whether the article is a technical or popular contribution, lecture, research result, thesis or special report, the format must contain the following features:
 - (i) brief and appropriate title;
 - (ii) the writer(s) name, designation/title, office/organization; and mailing address;
 - (iii) an abstract following ii) above;
 - (iv) body proper (text/discussion);
 - (v) conclusion/recommendation; and a
 - (vi) bibliography
- d. The printed copy must be numbered (Arabic numeral) successively at the top center whereas the disc copy pages should not be number. Tables, graphs and diagrams must likewise be numbered. Table numbers must precede table titles, e.g., "Table 1. Rate of Seeding per Hectare". Such table number and title must be typed at the top center of the table. On the other hand, graphs, diagrams, maps and photographs are considered figures in which case the captions must be indicated below the figure and preceded by number, e.g., "Figure 1. View of the Farm Buildings".
- e. **The data for the graph must also be included. (e.g. EXCEL for Windows)**
- f. Tables and figures must be preceded by texts or discussions. Inclusion of such tables and figures not otherwise referred to in the text/discussion must be avoided.
- g. Tables must be typed clearly without vertical lines or partitions. Horizontal lines must be drawn only to contain the sub-title heads of columns and at the bottom of the table.
- h. Express measurements in the metric system and crop yields in metric tons per hectare (t/ha) and smaller units in kilogram or gram (kg/plot or g/row).
- i. Indicate by footnotes or legends any abbreviations or symbols used in tables or figures.
- j. Convert national currencies in US dollars and use the later consistently.
- k. Round off numbers, if possible, to one or two decimal units, e.g., 45.5 kg/ha instead of 45.4762 kg/ha.
- l. When numbers must start a sentence, such numbers must be written in words, e.g., "Forty-five workers...", or "Five tractors..." instead of "45 workers...", or "5 tractors."

SUBSCRIPTION/ORDER FORM

AGRICULTURAL MECHANIZATION IN ASIA, AFRICA AND LATIN AMERICA (AMA)

Issued Quarterly

Subscription Rate (includes surface mail postage)

Annual (4 issues)..... ¥6,000
Single copy..... ¥1,700

(Check one)

- Please send me/us an invoice
- I/We enclose remittance for ¥ _____
- Please charge my/our credit card
 - VISA
 - MASTER Card. No. _____

Exp. date _____

Signature _____

We deeply appreciate your payment by credit card (NO EXTRA CHARGE NEEDED).
We charge you extra 4,000 JPY when paid by check, and 6,000 JPY when paid by wire transfer.

Name: _____

Firm: _____

Position: _____

Address: _____

(block letters)

FARM MACHINERY INDUSTRIAL RESEARCH CORP.
1-12-3 Kanda-Nishikicho, Chiyoda-ku, Tokyo 101-0054, Japan
Tel. (03)-3291-3674
URL: <http://www.shin-norin.co.jp>
E-Mail: ama@shin-norin.co.jp

CHANGZHOU DONGFENG Agricultural Machinery Group Co., Ltd. (DFAM)

DONGFENG BRAND TRACTOR SERIES



DONGFENG BRAND
CHINA WELL-KNOWN BRAND



DF-81BL POWER TILLER



DF-12L/15L POWER TILLER



Changzhou Dongfeng Agricultural Machinery Group Co., Ltd. (DFAM) is among the Top 3 of the tractor manufacturers in China.

Under the brand name of DONGFENG (DF), DFAM produces and sells around 50,000 sets of the Four-wheel Tractor ranging from 20-125 HP and over 100,000 sets of the Walking Tractor/Power Tiller ranging from 6-18 HP. Besides, DFAM also produce the farm implements under the Band Name of TOWNSUNNY. The annual sales is up to USD 310 million in 2010.

Since 1952, with excellent quality and competitive price, DFAM products enjoy very good reputation in the overseas markets and are widely accepted by the farmers of 105 countries and regions all over the world.

**CHANGZHOU DONGFENG AGRICULTURAL MACHINERY
GROUP CO., LTD. (DFAM)**

Add: 328, Xinye Road, Changzhou, Jiangsu, 213012, China.

Tel: 0086 519 83256666/83260303

Fax: 0086 519 83261722

Post code: 213012

E-mail: sales@df-tractor.com

Web Site: <http://www.df-tractor.com>

